

POLARIS™ POSITION

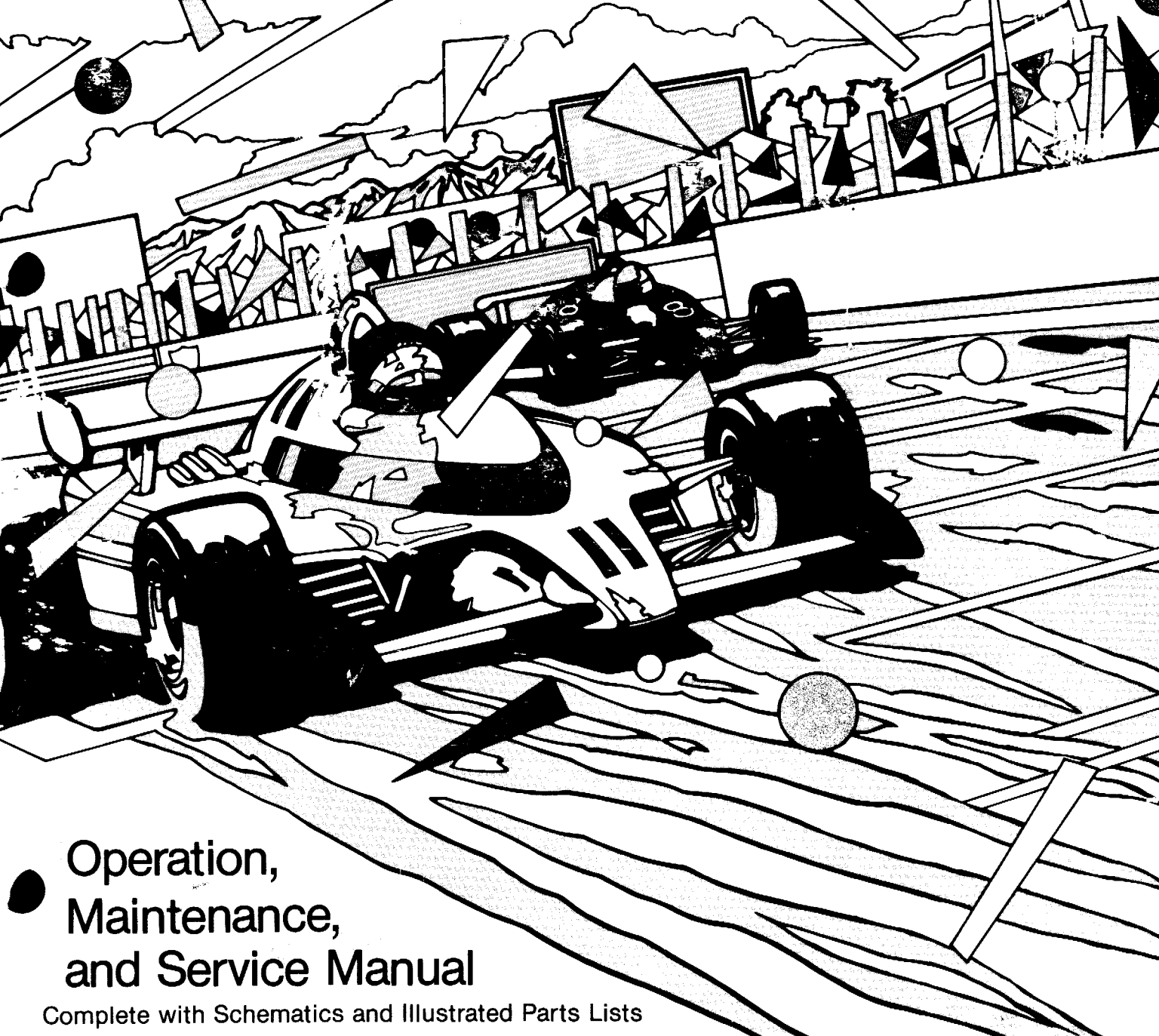

Operation,
Maintenance,
and Service Manual

Complete with Schematics and Illustrated Parts Lists

POLE POSITION™*

Operation, Maintenance, and Service Manual

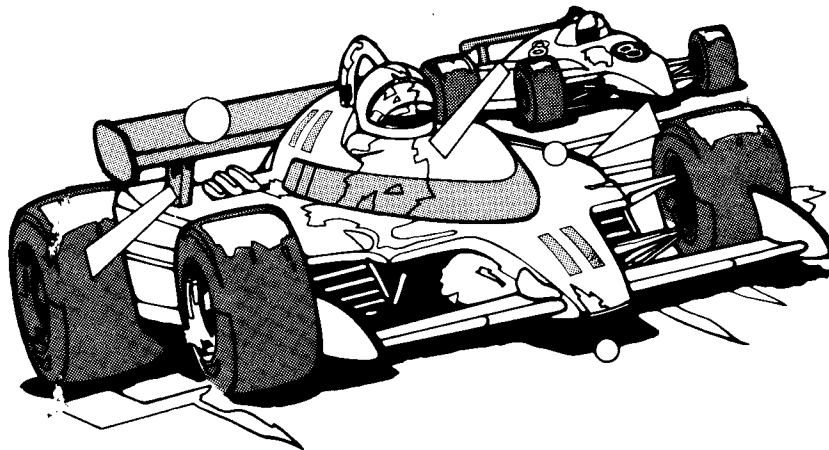

**Complete with Schematics
and Illustrated Parts Lists**

*Pole Position is engineered and designed by Namco Ltd. Manufactured under license by Atari, Inc.

© 1982 by Atari, Inc.

All rights reserved.

No part of this publication may be reproduced by any mechanical, photographic, or electronic process, or in the form of a phonographic recording, nor may it be stored in a retrieval system, transmitted, or otherwise copied for public or private use, without permission from the publisher.

The game play, all graphic designs, this technical manual, its accompanying schematic diagrams, and the display manual are protected by the U.S. Copyright Act of 1976.

This Act provides for increased penalties for violating federal copyright laws. Courts **can impound** infringing articles while legal action is pending. If infringers are convicted, courts can **order destruction** of the infringing articles.

In addition, the Act provides for payment of statutory damages of up to \$50,000 in certain cases. Infringers may also have to pay costs and attorneys' fees, fines up to \$25,000, and face an imprisonment of up to one year.

Atari will aggressively enforce its copyrights against any infringers. **We will use all legal means** to immediately halt any manufacture, distribution, or operation of a copy of video games made by us. Anyone who purchases such copies risks forfeiting such a game.

Published by:
ATARI, INC.
790 Sycamore Drive
P.O. Box 906
Milpitas, California 95035

Lithographed in the U.S.A. **2 M**

Notice Regarding Non-ATARI Parts

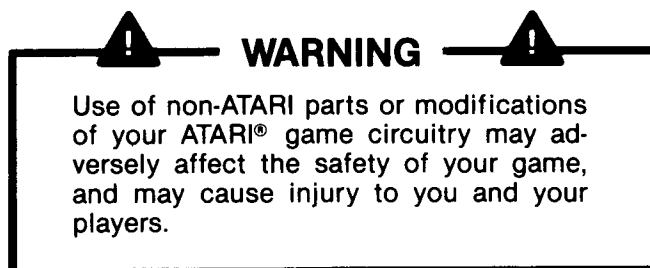

You may void the game warranty (printed on the inside back cover of this manual) if you do any of the following:

- substitute non-ATARI parts in the game
- modify or alter any circuits in the game by using kits or parts *not* supplied by Atari.

INTERFERENCE

to licensed communications services is not permitted by the Federal Communications Commission (FCC).

If you suspect interference from an ATARI® game at your location, check the following:

- all green ground wires in the game are properly connected as shown in the the game wiring diagram
- the power cord is properly plugged into a **grounded** 3-wire outlet
- the game PCB is properly installed within the Electromagnetic Interference (EMI) cage
- the EMI Shield PCB is properly installed and in series with the game PCB harness.

Refer to Figure 3-18 to make sure that the game PCB and the Shield PCB are correctly installed.

If you are still unable to solve the interference problem, please contact ATARI Customer Service. See the inside front cover for service in your area.

Table of Contents

1 Set-Up Procedures

A. New Features	1-4
B. Inspecting the Game	1-4
C. Leveling the Sit-Down Cabinet	1-5
D. Space and Power Requirements	1-5
1. Installation Requirements	1-5
2. Selecting the Voltage Plug	1-5
E. Locating the Switches	1-6
1. Power On/Off Switch	1-6
2. Utility Panel Switches	1-7
3. Option Switches	1-7
4. Memory Back-Up Jumper	1-7
F. Setting the Option Switches	1-7
G. Performing the Initial Self-Test	1-10
H. Game Play	1-12
1. Attract Mode	1-12
2. Play Mode	1-12
3. High-Score Mode	1-13
4. Hints for Game Play	1-13

2 Self-Test Procedure

A. Comments on Troubleshooting	2-2
B. Performing the Self-Test	2-2

3 Maintenance, Repair, and Parts

A. Cabinet-Mounted Assemblies	3-2
B. Player Controls	3-7
C. Fluorescent Tube and Speaker Replacement	3-20
D. Video Display	3-24
E. Utility Panel	3-26
F. Coin Doors	3-28
G. Printed-Circuit Boards	3-34
H. Power Supply Assembly	3-55

Glossary of Terms	GL-1
-------------------------	------

List of Illustrations

Figure 1-1	Game Overview, Upright Cabinet	1-2
Figure 1-2	Game Overview, Sit-Down Cabinet	1-3
Figure 1-3	Leveling the Sit-Down Cabinet	1-5
Figure 1-4	Location of Game Switches	1-6
Figure 1-5	Self-Test Display	1-11
Figure 2-1	Self-Test Screen 1: Upright Test Passes	2-3
Figure 2-2	Self-Test Screen 1: Sit-Down Test Passes	2-3
Figure 2-3	Self-Test Screen 1: Test Fails	2-3
Figure 2-4	Self-Test Screen 2	2-4
<i>Illustrated Parts Lists</i>		
Figure 3-1	Cabinet-Mounted Assemblies, Upright Cabinet	3-2
Figure 3-2	Cabinet-Mounted Assemblies, Sit-Down Cabinet	3-4
Figure 3-3	Control Panel	3-7
Figure 3-4	Control Panel Assembly	3-8
Figure 3-5	Steering-Wheel Control Assembly	3-10
Figure 3-6	Steering-Wheel Control Screw Adjustment	3-12
Figure 3-7	Steering-Wheel Control Orientation	3-13
Figure 3-8	Gear-Shifter Control Assembly	3-14
Figure 3-9	Foot-Pedal Control Assembly	3-16
Figure 3-10	Foot-Pedal Cable Rewinding	3-18
Figure 3-11	Fluorescent Tube and Speaker Board Removal, Upright Cabinet	3-20
Figure 3-12	Fluorescent Tube and Speaker Board Assembly Upright Cabinet	3-21
Figure 3-13	Sit-Down Cabinet Speaker Removal	3-22
Figure 3-14	Video Display	3-25
Figure 3-15	Utility Panel Assembly	3-26
Figure 3-16	Vertically Mounted Coin Door	3-28
Figure 3-17	American-Made Coin Door	3-31
Figure 3-18	Removing the Printed-Circuit Boards	3-34
Figure 3-19	Central Processing Unit Printed-Circuit Board Assembly	3-36
Figure 3-20	Pole Position Video Printed-Circuit Board Assembly	3-44
Figure 3-21	Regulator/Audio II PCB Assembly, U.S.-Built Cabinet	3-49
Figure 3-22	Regulator/Audio II PCB Assembly, Ireland-Built Cabinet	3-50
Figure 3-23	EMI Shield PCB Assembly	3-53
Figure 3-24	Power Supply Assembly	3-55

List of Tables

Table 1-1	Switch Settings for Game and Price Options	1-8
Table 1-2	Switch Settings for Game and Play Options	1-9
Table 1-3	Self-Test Procedure	1-10
Table 1-4	Qualifying Lap Information	1-13
Table 2-1	Locating Failed Components on the Video PCB	2-2
Table 2-2	Locating Failed Components on the CPU PCB	2-2
Table 2-3	Locating the Failed ROM	2-3
Table 2-4	Locating the Failed RAM	2-4

NOTICE

This equipment generates, uses, and can radiate radio frequency energy and if not installed and used in accordance with the instruction manual, may cause interference to radio communications. It has been tested and found to comply with the limits for a Class A computing device pursuant to Subpart J of Part 15 of FCC Rules, which are designed to provide reasonable protection against such interference when operated in a commercial environment. Operation of this equipment in a residential area is likely to cause interference in which case the user, at his own expense, will be required to take whatever measures may be required to correct the interference.

Set-Up Procedures

How to Use this Manual

This manual, written for game operators and service technicians, describes the Pole Position game. The manual contains information about the *Upright* and *Sit-Down* Pole Position cabinets.

Whenever information is unique to the *Upright* cabinet, this symbol appears:



Whenever information is unique to the *Sit-Down* cabinet, this symbol appears:



Wherever information is unique to *Ireland-Built* games, this symbol appears:



Chapter 1 describes new features, game setup, settings of option switches, self-test procedures, and game play.

Chapter 2 contains self-test procedures.

Chapter 3 details maintenance, repair, and parts information.

A **glossary of terms** is in the back of this manual for your convenience.

In addition, schematic diagrams of the game circuitry are included with this manual.

Figures 1-1 and 3-1 illustrate the *Upright* game cabinet; Figures 1-2 and 3-2 illustrate the *Sit-Down* game cabinet. Italicized lettering on these figures refers you to other places in the manual for information about specific cabinet parts.

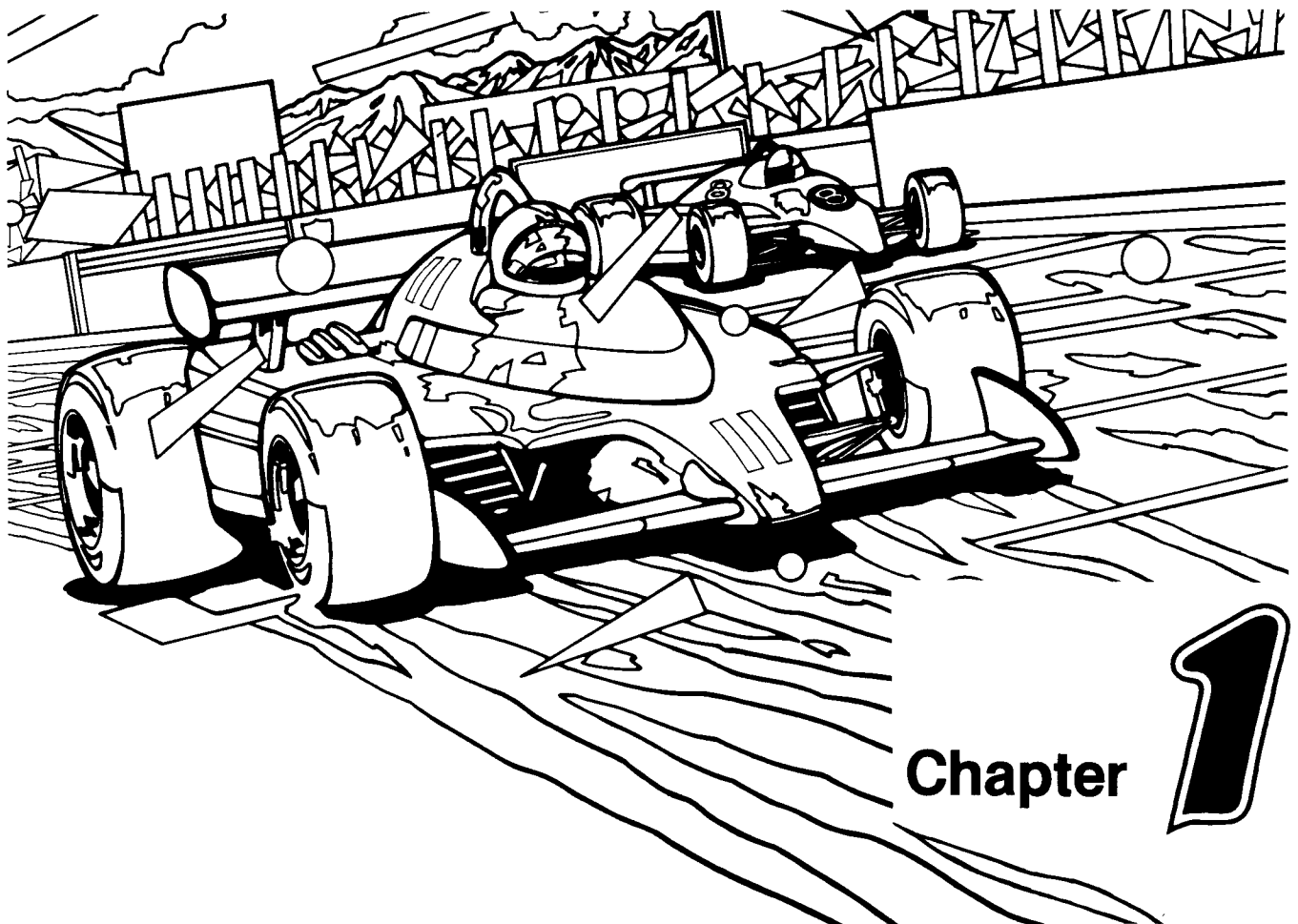

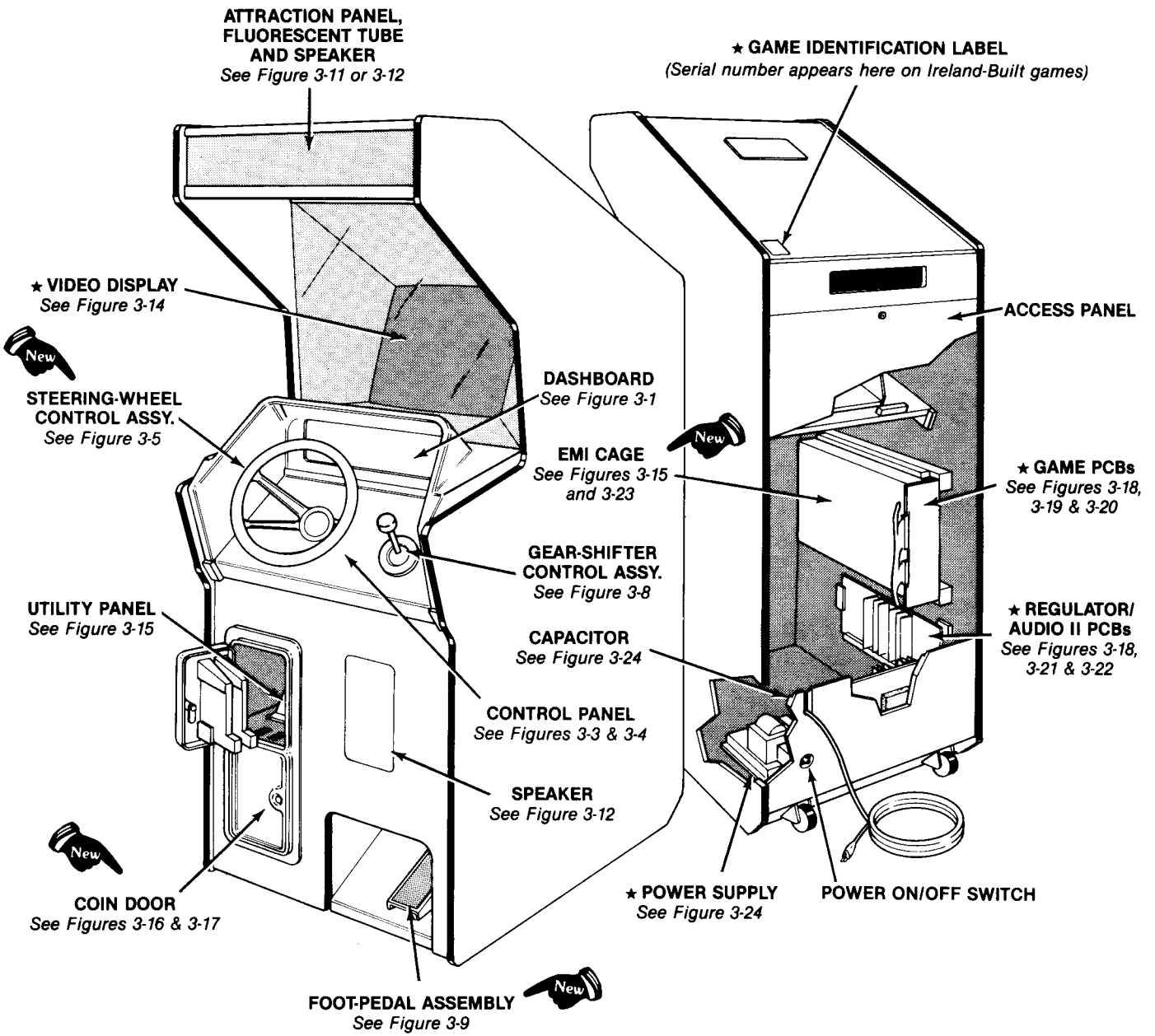

★ Items with a serial number label on U.S.-Built cabinets

WARNING

SHOCK HAZARD

This game should only be connected to a grounded 3-wire outlet. If you have only a 2-wire outlet, we recommend you hire a licensed electrician to install a grounded outlet. You may receive an electrical shock if the game is not properly grounded!

Figure 1-1 Game Overview Upright Cabinet

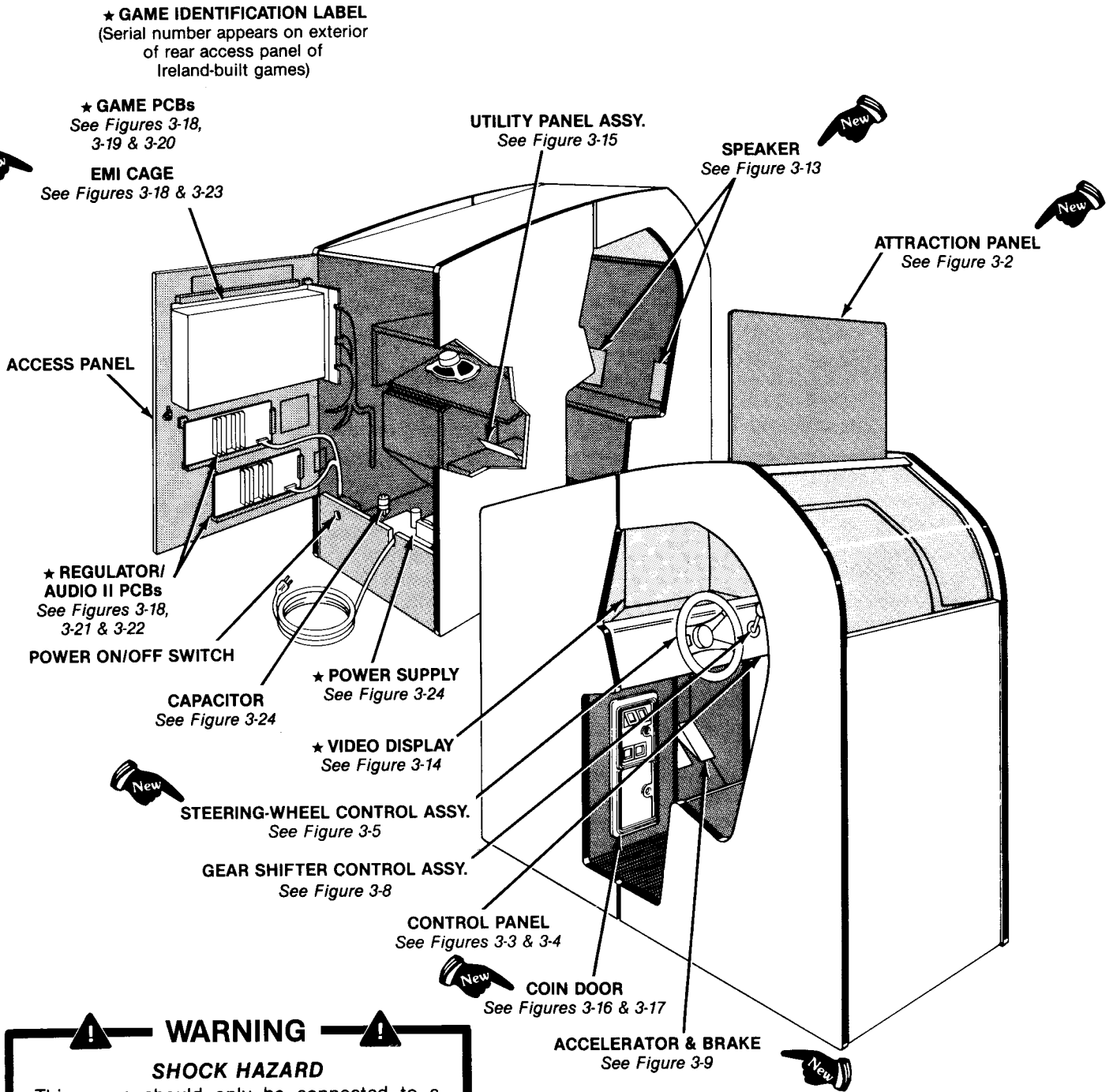

WARNING

SHOCK HAZARD

This game should only be connected to a grounded 3-wire outlet. If you have only a 2-wire outlet, we recommend you hire a licensed electrician to install a grounded outlet. You may receive an electrical shock if the game is not properly grounded!

★ Items with a serial number label on U.S.-Built cabinets

Figure 1-2 Game Overview Sit-Down Cabinet

A. New Features

The Pole Position game has many new features. Even if you are familiar with ATARI® games, you should note these important differences:

- **Electromagnetic Interference (EMI) Cage in U.S.-Built Cabinets Only.** Games built after December 1, 1982, will have the CPU and Video printed-circuit boards (PCBs) mounted inside this cage. The EMI cage reduces interference from the game to television and radio receivers. See *Figure 3-18* for details.
- **American-Made Coin Door.** Your game may be equipped with a new coin door. This door is very similar to the vertically mounted coin door, but does not have lockout coils. When ordering parts for your coin door, please check coin door illustrations in Figures 3-16 and 3-17 carefully to make sure you are ordering the correct part number.
- **Steering-Wheel Control.** This steering wheel is designed to provide a more realistic response from the race car on the display.
- **Foot-Pedal Control (Accelerator and/or Brake).** These pedals have been redesigned to accommodate a snap-action switch for the brake and a potentiometer, turned by a spring and cable, for the accelerator.
- **Metal Attraction Panel on Sit-Down Game Cabinet.** The metal attraction panel mounted on top of the cabinet entices players with its Formula-1 racing graphics.
- **Quadraphonic Sound in Sit-Down Cabinet.** Four 4-ohm, 6-ounce, high-fidelity speakers (two under the control panel; two behind the seat) surround the player with the exciting and realistic sounds of Gran Prix racing.

New features and other major parts of the game are shown in Figures 1-1 and 1-2. Throughout this manual, wherever a new feature is mentioned, you will see this symbol:

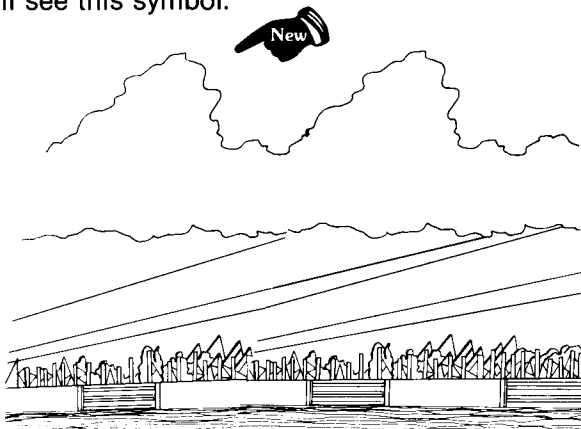

B. Inspecting the Game

Please inspect your game carefully to ensure that it was delivered to you in good condition.



WARNING



To avoid electrical shock, do not plug in the game until the procedures in Sections B, C, and D have been completed!

1. Examine the exterior of the game cabinet for dents, chips, or broken parts.
2. Remove the screws that were used as extra security to seal the rear access panel. Unlock and open this panel and the coin door; inspect the interior of the game as follows:
 - a. Ensure that all plug-in connectors (on the game harness) are firmly plugged in. Replug any connectors found unplugged. **Do not force connectors together.** The connectors are keyed so they only fit in the proper orientation. **A reversed edge connector may damage a PCB** and will void your warranty.
 - b. Ensure that all plug-in integrated circuits are firmly plugged into their sockets on the printed-circuit boards (PCBs).
 - c. Remove the tie-wrap that secures the coiled power cord inside the cabinet. Inspect the power cord for any cuts or dents in the insulation. Repair or replace it as required. Place the square black plastic strain-relief plate in the wood slot at the bottom of the rear panel opening.
 - d. Note the game serial number printed on a label on the back of the cabinet. Verify that the same serial number is also on the Pole Position game PCBs, Regulator/Audio II PCBs, power supply, and video display. See *Figures 1-1 and 1-2* for locations of the serial-numbered components. Please mention the serial number whenever you call your distributor for service.
 - e. Inspect major subassemblies, such as the power supply, control panel, and video display. Make sure they are mounted securely.



WARNING



To avoid electrical shock, do not touch internal parts of the display with your hands or with metal objects held in your hands!

- For the *Sit-Down* cabinet, remove the metal attraction panel from the protective wrapping. Remove the three button-head screws and retainer on the front window. Place the attraction panel over the mounting holes. Reinstall the retainer and screws.

C. Leveling the Sit-Down Cabinet

The *Sit-Down* cabinet rolls easily from location to location on 4-inch casters. To level the cabinet, lift the game up on one side. Place a block of wood, a book, or another object (that is at least 2-inches thick) under the raised cabinet. Partially unscrew the adjustable glides (see *Figure 1-3*) until they extend below the caster.

Lower the game and lift it up on the other side; partially unscrew the adjustable glides. Lower the game.

To prevent players from moving the game around, be sure to adjust all four glides.

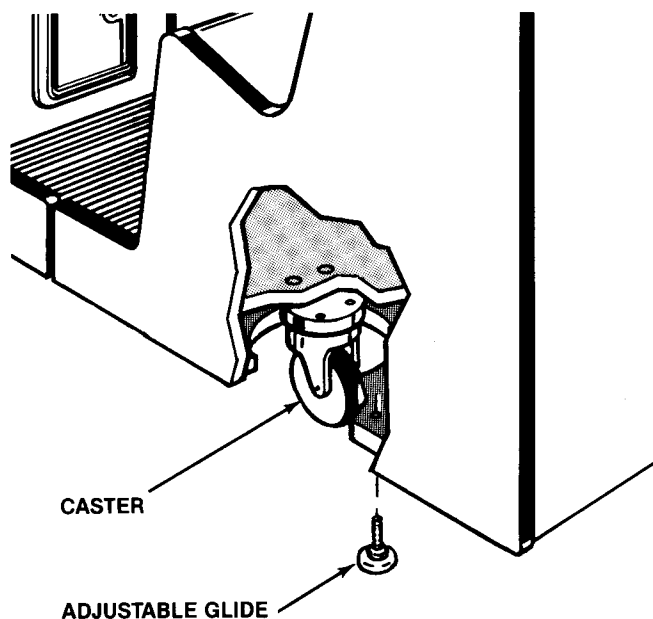

Figure 1-3 Leveling the Sit-Down Cabinet

D. Space and Power Requirements

1. Installation Requirements

Power	250 W
Temperature	0° to +38°C (+32° to +100°F)
Humidity	Not over 95% relative

Upright Cabinet

Space Required	62 x 90 cm (25¼ x 35½ in.)
Game Height	186 cm (72¾ in.)

Sit-Down Cabinet

Space Required	165 x 64 cm (65 x 25¼ in.)
Game Height	194 cm (76 in.)

2. Selecting the Voltage Plug

WARNING

SHOCK HAZARD

This game should only be connected to a grounded 3-wire outlet. If you have only a 2-wire outlet, we recommend you hire a licensed electrician to install a grounded outlet. *You may receive an electrical shock if the game is not properly grounded!*

The power supply used in this game operates on the line voltage of almost any country in the world. The power supply comes with either one, two, or three separate voltage-selection plugs. Plug voltages and wire colors are 100 VAC (violet wire color), 120 VAC (yellow wire color), 220 VAC (blue wire color), and 240 VAC (brown wire color).

Before plugging in your game, check your line voltage. Next, check the wire color on the voltage-selection plug that is plugged into the game's power supply. Make sure the voltage-selection plug is correct for the voltage of your location (see *Figure 3-24*).

Now, plug the game into a grounded 3-wire outlet.

E. Locating the Switches

CAUTION

Do not depress the accelerator or brake pedal when turning on the game or switching to the Self-Test Mode. This will cause faulty program initialization and incorrect action of the player controls.

1. Power On/Off Switch

The power on/off switch is located on the back of the *Upright* cabinet on the lower left side. On the *Sit-Down* cabinet the power on/off switch is located on the lower left side of the cabinet (see *Figure 1-4*).

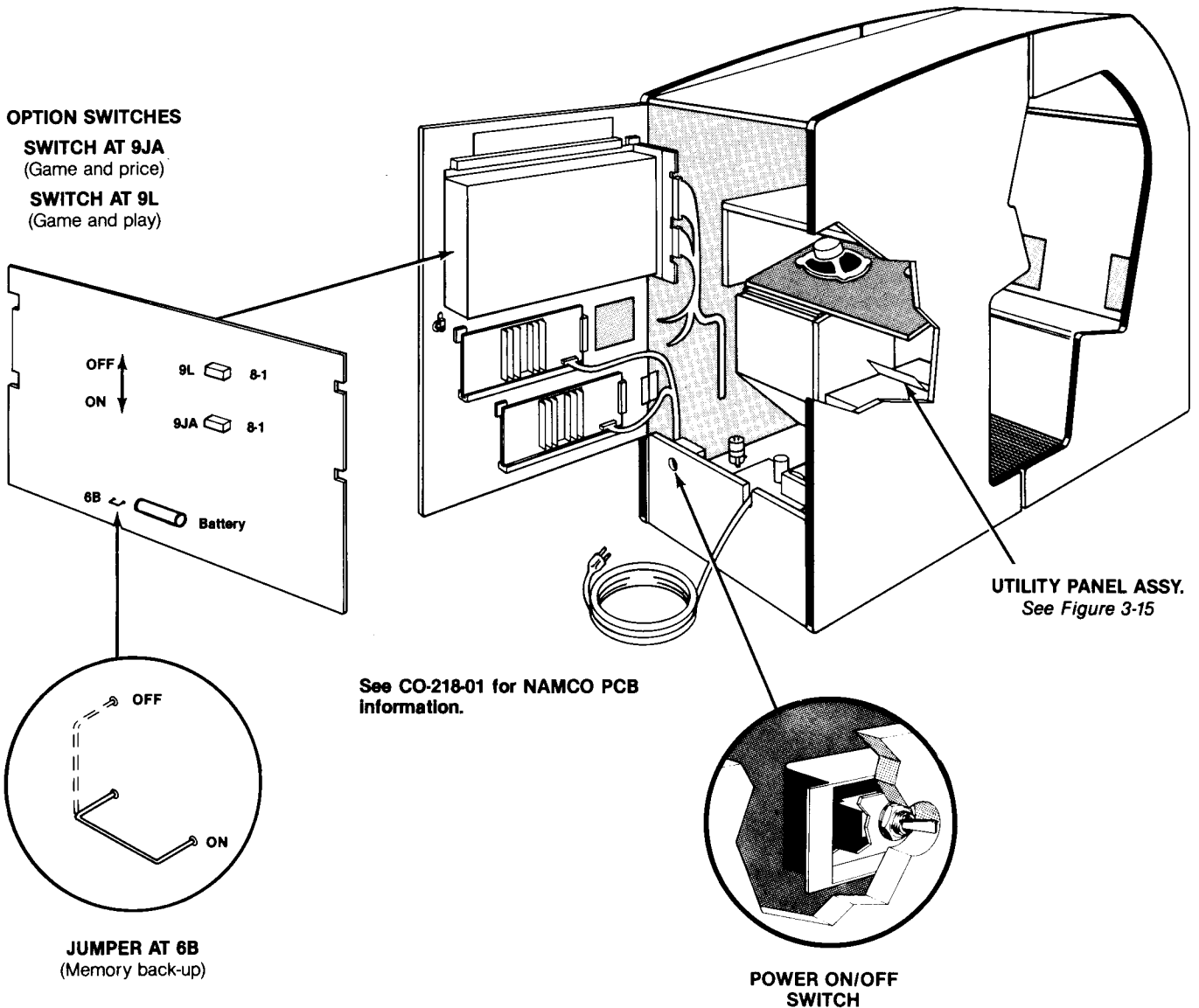

Figure 1-4 Location of Game Switches

2. Utility Panel Switches

The volume control(s), self-test switch, coin counter(s), and auxiliary coin switch are located on the utility panel in both the *Upright* and *Sit-Down* cabinets (see *Figure 3-12*). The utility panel is located inside the upper coin door. The volume control(s) adjust the level of sound produced by the game. The *Sit-Down* cabinet has four volume controls: one for each speaker. The *Upright* cabinet has two volume controls: one for each speaker. The self-test switch is used to enter and exit the Self-Test Mode. The coin counter(s) record the number of coins entered into the game. The auxiliary coin switch is used to credit the game without activating the coin counter(s).

3. Option Switches

Option switches are located on the game CPU PCB (see *Figure 1-4*). Refer to supplement CO-218-01 for switch locations if your game has NAMCO PCBs.

- Game and price options are at CPU PCB location 9JA.
- Game and play options are at CPU PCB location 9L.

4. Memory Back-Up Jumper

The memory back-up jumper is at CPU PCB location 6B. Position this jumper to the *on* setting. The memory back-up jumper is positioned on the *off* setting when shipped from the factory to prevent leakage and to provide longer life for the battery at location 6A on the CPU PCB. The jumper must be positioned to the *on* setting so that the battery can provide power to the CMOS memory. This memory stores the high-score table and operator statistics.

The jumper does not affect game play. We recommend you position this jumper to the *off* setting when you expect extended downtime.

F. Setting the Option Switches

Settings of the game option switches are explained in Tables 1-1 and 1-2. Options preset at the factory are shown by the ◀ symbols. However, you may change the settings according to your individual needs.

To verify option-switch settings, first set the power on/off switch to the *off* position and then to the *on* position. Next, set the self-test switch to the *on* position. Compare the information on the screen to the option switch settings listed in the tables in this section. Then set the self-test switch to the *off* position.

Table 1-1 describes the switch settings for options relating to game price, coin mechanism multipliers, number of laps per game, and number of seconds per lap. These switches are on the game CPU PCB at location 9JA.

The *multipliers* (9JA switches 1-5) determine the value of the coin mechanisms to the game's logic. A *coin mechanism* is a device on the inside of the coin door that inspects the coin to determine if the correct coin has been inserted. The mechanism either accepts or rejects the coin. The coin door has two coin mechanisms.

The basic unit of measurement is a coin worth \$.25 or 1 DM, which equals a multiplier of x1. For example, if you have a 2 DM/1 DM coin door, you may want to set the left multiplier at x2 and the right multiplier at x1.

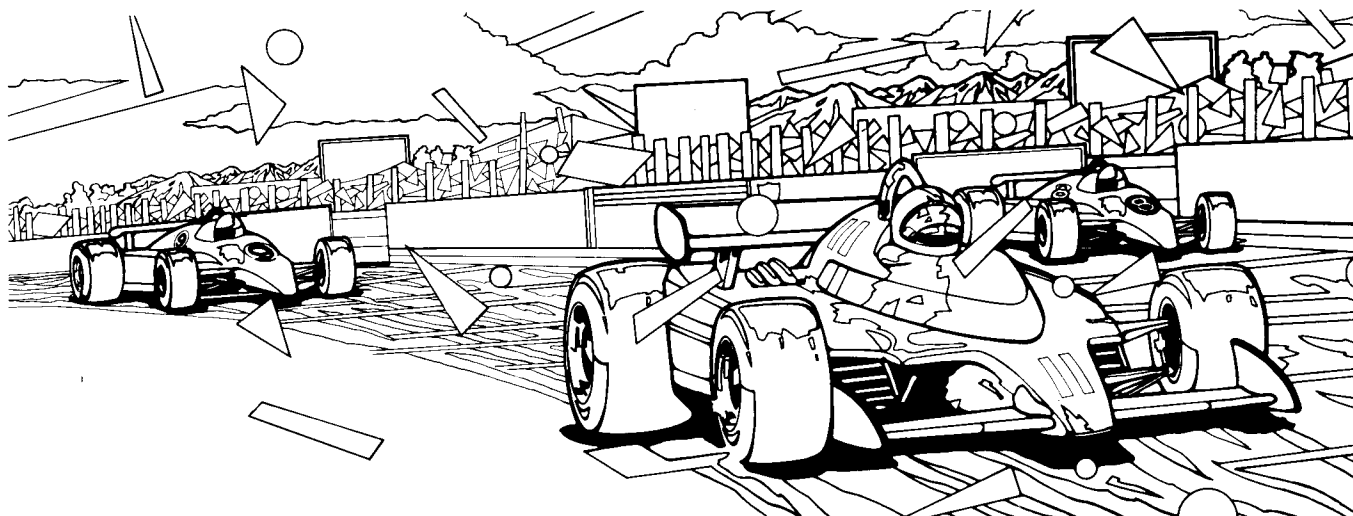

NOTE

Coin Option Interconnect Assembly J55A-P55A permits a coin placed in either coin mechanism to register in the same coin counter. The cable connector is located between the coin door harness and the main harness (see the Coin Option Interconnect Wiring Diagram in SP-218). When it is used, left coin mechanism option switches at 9JA apply to both coin mechanisms.

If you want different options for the left and right coin mechanisms, remove Coin Option Interconnect Assembly J55A-P55A and connect J55 directly to P55.

If you have NAMCO game PCBs, refer to CO-218-01 for the location of the option switches.

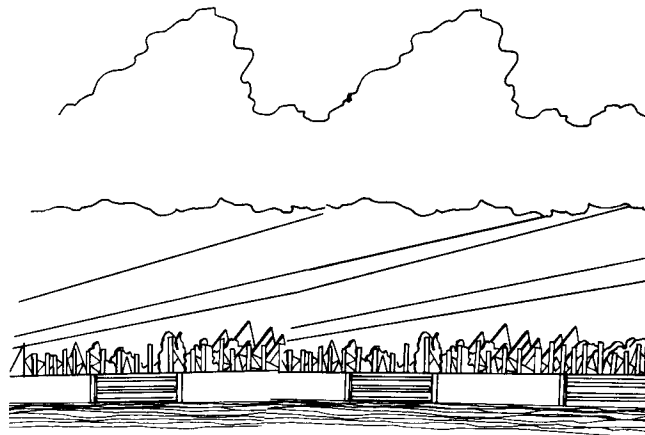

Table 1-1 Switch Settings for Game and Price Options

Settings of 8-Toggle Switch on Pole Position CPU PCB (at 9JA)

8	7	6	5	4	3	2	1	Option
On								4 racing laps ★
Off								3 racing laps ◀
	Off	Off						90 seconds per lap ◀
	Off	On						100 seconds per lap
	On	Off						110 seconds per lap
	On	On						120 seconds per lap ★
			Off	Off				Right Coin Mechanism
			Off	On				1 coin for 1 credit ◀
			On	Off				2 coins for 1 credit ★
			On	On				3 coins for 2 credits
			On	On				4 coins for 3 credits
					Off	Off	Off	Left Coin Mechanism
					Off	Off	On	1 coin for 1 credit ◀
					Off	On	Off	1 coin for 2 credits
					Off	On	Off	1 coin for 3 credits
					Off	On	On	2 coins for 1 credit ★
					On	Off	Off	3 coins for 1 credit
					On	Off	On	3 coins for 2 credits
					On	On	Off	4 coins for 3 credits *
					On	On	On	Free Play

◀Manufacturer's recommended settings for Upright cabinet
 ★ Manufacturer's recommended settings for Sit-Down cabinet
 * This option setting can be changed to 1 coin for 6 credits by changing the program PROM (136014-160). Contact your distributor for further information.

NOTE

We recommend that game difficulty for the race laps (EXTENDED RANK) and the qualifying lap (PRACTICE RANK) be increased periodically. These changes will ensure that Pole Position continues to offer maximum excitement and challenge. Except in locations with extremely skillful and advanced players, these settings should not be increased more than one level per month.

Table 1-2 contains option-switch settings for Attract Mode sound and speed (kilometers or miles per hour). These switches are on the game CPU PCB at location 9L.

Pole Position leaves the factory with option switches set at the manufacturer's recommended difficulty level. The game will be exciting and challenging for players at these settings.

Table 1-4 lists the manufacturer's recommended qualifying lap times. Table 1-5 lists option-switch settings for additional qualifying lap times. Table 1-6 provides switch settings for racing lap times.

Table 1-2 Switch Settings for Game and Play Options

Refer to CO-218-01 for switch locations if your game is equipped with NAMCO PCBs.

Settings of 8-Toggle Switch on Pole Position CPU PCB (at 9L)

8	7	6	5	4	3	2	1	Option
Off								Attract Mode sound off
On								Attract Mode sound on ◀
	Off							Kilometers per hour
	On							Miles per hour ◀

◀Manufacturer's recommended settings

G. Performing the Initial Self-Test

This game will test itself and provide data to show that the game's circuitry and controls are operating properly. The data is provided on the video display and speakers. No additional equipment is necessary.

Wait at least 10 seconds after playing a game before switching to the Self-Test Mode. Otherwise, you may erase the top three scores in the high-score table or distort the statistics. All credits will be cancelled when you switch to self-test.

Refer to *Figure 1-4* for the location of the option switches and *Figure 3-15* for the location of the self-test switch. Set the self-test switch to the *on* position (see *Figure 1-5*) to see the Self-Test Display in the Self-Test Mode. To exit the Self-Test Mode, set the self-test switch to the *off* position.

The complete self-test procedure is explained in *Chapter 2, B. Self-Test Procedure*. If a part of the test described in Table 1-3 fails, refer to Chapter 2.

We suggest you perform the self-test procedure when you first set up the game, when you collect money from the game, when you change game options, or when you suspect game failure.

CAUTION

Do not depress the accelerator or brake pedal when turning on the game or switching to the Self-Test Mode. This will cause faulty program initialization and incorrect action of the player controls.

Table 1-3 Self-Test Procedure

Instruction	Test Passes
1. Without touching the pedal(s), set the self-test switch to the <i>on</i> position. All credits will be cancelled.	Random symbols are displayed on the screen for about five seconds. The self-test display appears. RAMs and ROMs are tested. If the screen is different from the self-test display, or if there are sounds, refer to <i>Chapter 2, Self-Test Procedure</i> .
2. Press down on the accelerator pedal.	The numbers to the right of <i>ACCEL</i> increase from <i>00</i> to somewhere between <i>90</i> and <i>A0</i> as you press down on the pedal. If the test fails refer to <i>Chapter 2</i> .
3. Press down on the brake pedal of the <i>Sit-Down cabinet</i> .	The numbers to the right of <i>BRAKE</i> switch from <i>00</i> to <i>FF</i> . For the <i>Upright cabinet</i> , the numbers to the right of <i>BRAKE</i> should always read <i>00</i> . If the test fails, refer to <i>Chapter 2</i> .
4. Turn the steering wheel clockwise, then counterclockwise.	Rotating the wheel clockwise causes the numbers to the right of <i>STEERING</i> to increase. Rotating the wheel counterclockwise causes the numbers to decrease. If the test fails refer to <i>Chapter 2</i> .
5. Shift the gear shifter.	The words to the right of <i>SHIFT</i> change from <i>LO</i> (shifter up) to <i>HI</i> (shifter down) as you shift gears. If the test fails, refer to <i>Chapter 2</i> .
6. Shift the gear shift, press the auxiliary coin switch, and activate the coin switches.	The numbers to the right of <i>SOUND</i> increase from <i>00</i> to <i>20</i> , and a new sound is played with each number. Test all 20 sounds. If the test fails, refer to <i>Chapter 2</i> .
7. Press the auxiliary coin switch.	Game statistics appear (for a few seconds) at the bottom of the screen. Press the coin switch each time you want to see the statistics. To erase game statistics , simultaneously press down on the accelerator pedal and press the auxiliary coin switch twice. Statistics will be reset at <i>/999/</i> . To reset the high-score table , simultaneously press down on the accelerator pedal and change gear shifter from low to high. The high-score table will be reset and contain fictitious scores.
8. To end the test, switch the self-test switch to <i>off</i> .	

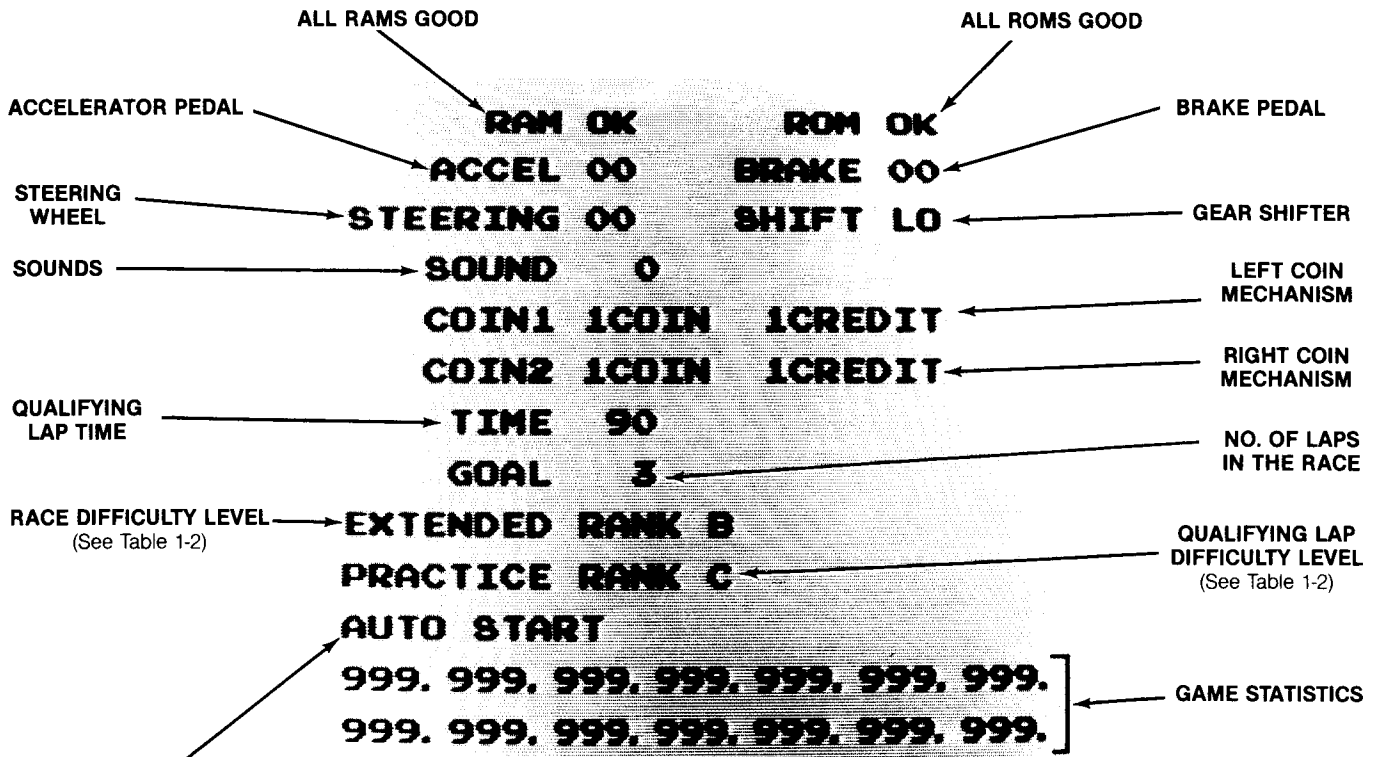

THE COUNT STARTS AT 999(999) AND DECREASES. For example, if you play 10 games, the game subtracts 10 from 99.9, and the display shows 98.9 for the number of games played. (Disregard decimal points.)

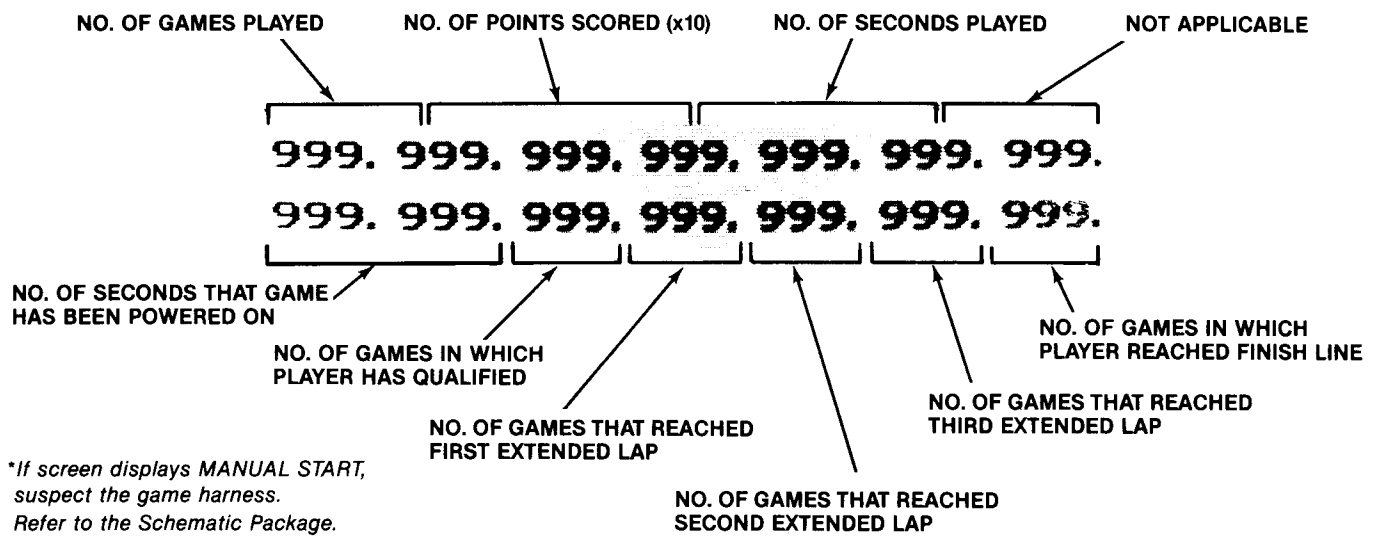

**If screen displays MANUAL START, suspect the game harness. Refer to the Schematic Package.*

Figure 1-5 Self-Test Display

H. Game Play

Pole Position is a one-player game using a color raster-scan video display. The game action takes place at Fuji Speedway in Japan. The country around the speedway consists of green meadows, hills, and snow-capped Mt. Fuji.

The player drives a Formula-1 race car on the Fuji Speedway. Player controls consist of a steering wheel, a two-position gear shifter, and accelerator and brake pedals on the *Sit-Down* cabinet (accelerator only on the *Upright* cabinet). The object of the game is to finish the qualifying lap as quickly as possible. If the player beats the clock, he qualifies for the Gran Prix at Fuji Speedway; if not, he drives out the remainder of his time along the qualifying course.

As a qualifier, the driver is ranked according to his qualifying lap time, from position one (the pole position) to position eight. The player then races against the clock and other cars to finish the four laps (operator-selectable option) of the race as fast as possible and to achieve the highest score possible. The player earns points for passing cars, driving on the track, and finishing the race with time remaining. He is rewarded with an extended-play lap for completing a lap.

Pole Position has four modes of operation: Attract, Play, High-Score, and Self-Test. Self-Test is a special mode for checking the game switches and computer functions. You may enter the Self-Test Mode from any other mode. However, all credits will be cancelled.

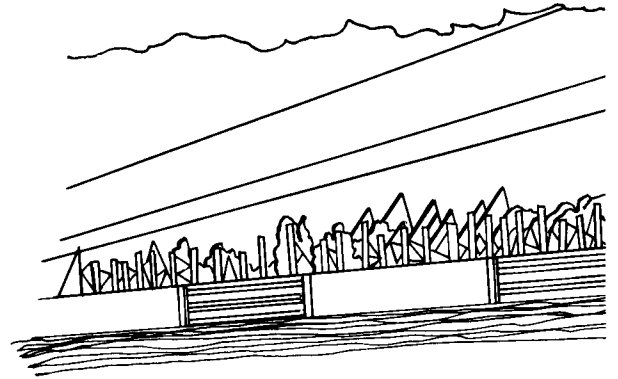
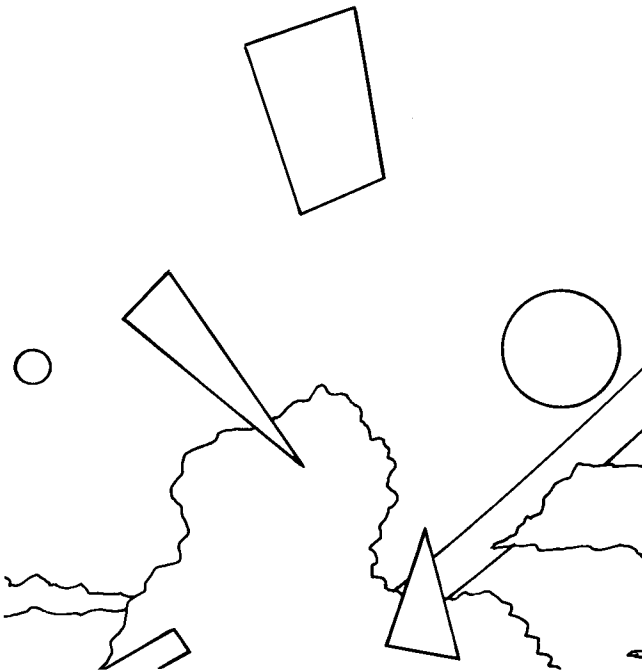

1. Attract Mode

The Attract Mode begins when you set the power on/off switch to *on* or after the Play, High-Score, or Self-Test Modes. The Attract Mode ends when the correct amount of credit for a game is inserted or when the Self-Test Mode begins.

When the Attract Mode begins, the game displays a picture with the words *POLE POSITION* flashing at the top of the screen. A map of Fuji Speedway is displayed in the center of the screen. Within the map are the words *FUJI SPEEDWAY* and *1 LAP 3459M*. At the bottom of the screen is the copyright message.

Then, the Attract Mode simulates game play. Eight cars are at the starting line. The player's car, located in the eighth position, flashes on the screen. The starting lights flash from red to green and the race starts. The race continues until the player's car crashes into another car and explodes into a red ball of fire. Then, the car reappears on the screen and continues down the track until it hits a sign along the side of the road. Again, the car explodes. During this sequence, the message *GAME OVER* appears in the center of the screen.

Finally, the Attract Mode displays the High-Score Table. The fastest lap time, average game speed, and prize winners appear at the top of the screen. Below this information is a list of the six highest scores. Opposite each score are the initials of the player who achieved that score.

2. Play Mode

The Play Mode begins when the correct amount of credit for a game is recorded. The game starts with the player's car behind the starting line and 90 seconds on the clock. (See *Section E* to select a different clock setting.) The car must finish the qualifying lap within 73 seconds to be in the race. If the player does not qualify, his car continues on the track until 90 seconds are used up.

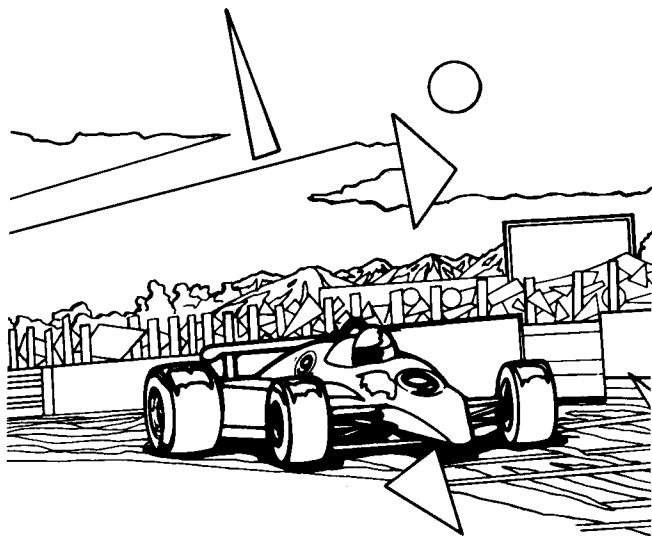

Table 1-4 Qualifying Lap Information

POSITION	QUALIFYING LAP TIME*	BONUS POINTS
1	58" 50	4000
2	60" 00	2000
3	62" 00	1400
4	64" 00	1000
5	66" 00	800
6	68" 00	600
7	70" 00	400
8	73" 00	200

*In seconds and hundredths of a second

★ The above times apply to manufacturer's recommended settings.

Just before the race begins, the player's car (flashing on the screen) is placed at the starting line with seven other cars. The position of the car depends on the qualifying time as shown in Tables 1-4 or 1-5.

The starting lights flash from red to green, and the race begins. Racing hazards are other racing cars, sharp turns, and road signs. As the race progresses, more cars appear on the track. If the driver's car hits another car or a road sign, the driver's car is destroyed in an explosion. The driver's car reappears in a few seconds and the race continues. Driving through wet puddles or off the track slows down the driver's car.

Racing into the first turn, the driver must let up on the accelerator slightly to make the corner. Road signs flash along the side of the track. Depending on how well the player manipulates the controls, he can either roar through the hairpin turns like a champion or spin out in a flaming crash. He jockeys for position with the other racers, while keeping his eye on the clock at the top of the screen. When his time runs out, the race is over.

The top score achieved by a player appears at the top of the screen. The time allotted for the lap is displayed under the top score. Increasing lap time (in seconds and hundredths of a second) and the speed of the car appears last.

3. High-Score Mode

The High-Score Mode begins when a player has earned one of the 300 highest scores. The player has one minute to record his initials. A player rotates the steering wheel to locate his initial. He presses a foot pedal to put his initial on the screen. The third time he presses the pedal his initials are transferred into the high-score table.

4. Hints for Game Play

- Avoid puddles and the sides of the track because these slow you down.
- Accelerate and stay ahead of other racers.
- Stick to the inside of the track to make the corners.
- Successful completion of a turn depends on braking skill.
- When sliding, steer into the skid.

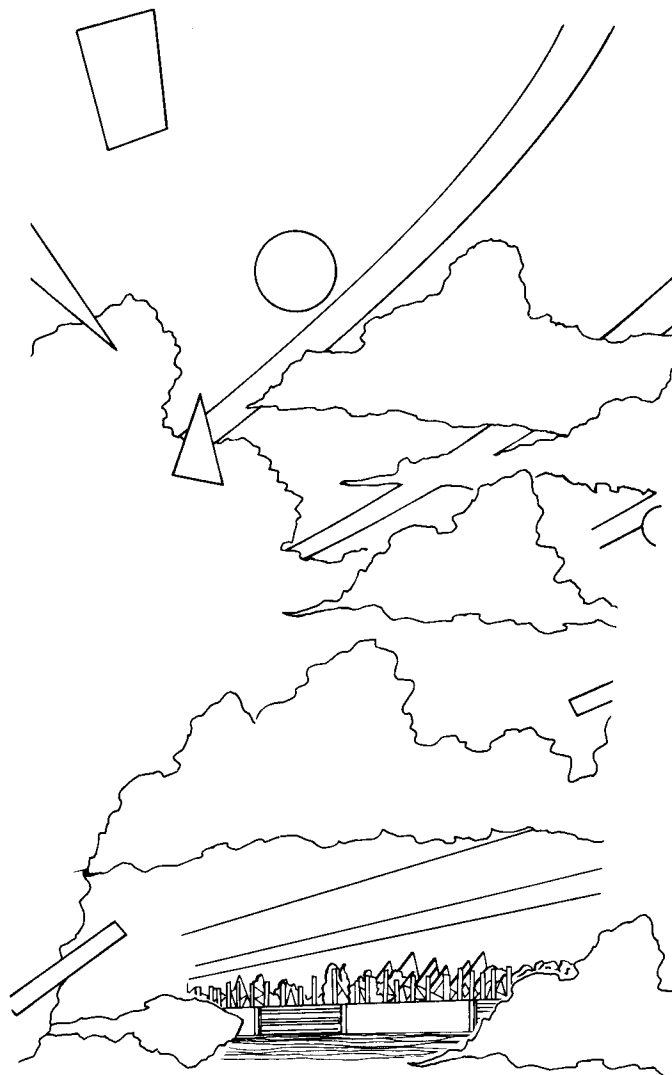

Table 1-5 Switch Settings for Qualifying Lap Times

9L Option Switches			Self-Test Practice Rank	Level of Difficulty	Beat This Many Seconds to Qualify for Position:							
1	2	3			1	2	3	4	5	6	7	8
On	Off	On	F	Easy ↓ Hard	66	68	70	73	75	77	80	82
Off	Off	On	E		65½	67½	70	72½	74½	76½	79	81
On	On	On	H		59½	61	63	66	68	70	72	75
On	On	Off	D		59	61	63	65	67	69	71	74
Off	On	Off	C◀		58½	60	62	64	66	68	70	73
On	Off	Off	B		58	60	62	64	66	68	70	72
Off	Off	Off	A		57½	59	61	63	65	67	69	71
Off	On	On	G		57	59	61	63	65	67	69	71

◀Manufacturer's recommended settings

Table 1-6 Switch Settings for Racing Lap Times

9L Option Switches			9JA Option Switch 8	Self-Test		Top Speed		Number of Seconds			
4	5	6		Goal	Extended Rank	MPH	KPH	Lap 1	Lap 2	Lap 3	Lap 4
Off	Off	Off	Off	3	A	195	313	75	50	61	—
Off	Off	Off	On	4	A	195	313	75	53	58	62
Off	On	Off	Off	3	C	195	313	75	48	60	—
Off	On	Off	On	4	C	195	313	75	51	57	61
On	Off	Off	Off	3	B◀*	195	313	75	46	59	—
On	Off	Off	On	4	B◀**	195	313	75	49	56	60
On	On	Off	Off	3	D	195	313	75	44	58	—
On	On	Off	On	4	D	195	313	75	47	55	59
Off	Off	On	Off	3	E	225	360	75	48	60	—
Off	Off	On	On	4	E	225	360	75	51	57	61
On	Off	On	Off	3	F	225	360	75	46	59	—
On	Off	On	On	4	F	225	360	75	49	56	60
Off	On	On	Off	3	G	244	391	75	48	60	—
Off	On	On	On	4	G	244	391	75	51	57	61
On	On	On	Off	3	H	244	391	75	46	59	—
On	On	On	On	4	H	244	391	75	49	56	60

◀Manufacturer's recommended settings

*Upright cabinet
**Sit-down cabinet

Self-Test Procedure

NOTE

The reference designators for components in this chapter refer to games with Atari® PCBs. If you have Namco PCBs, please refer to CO-218-01.

The following self-test procedures should be performed by a qualified electronic technician.

This game tests itself when the self-test switch is set to the *on* position. If there is a failure, the game produces audiovisual aids to help you find the failing portion of the game. The self-test procedure included in Chapter 1 will help you decide if the game is working properly.

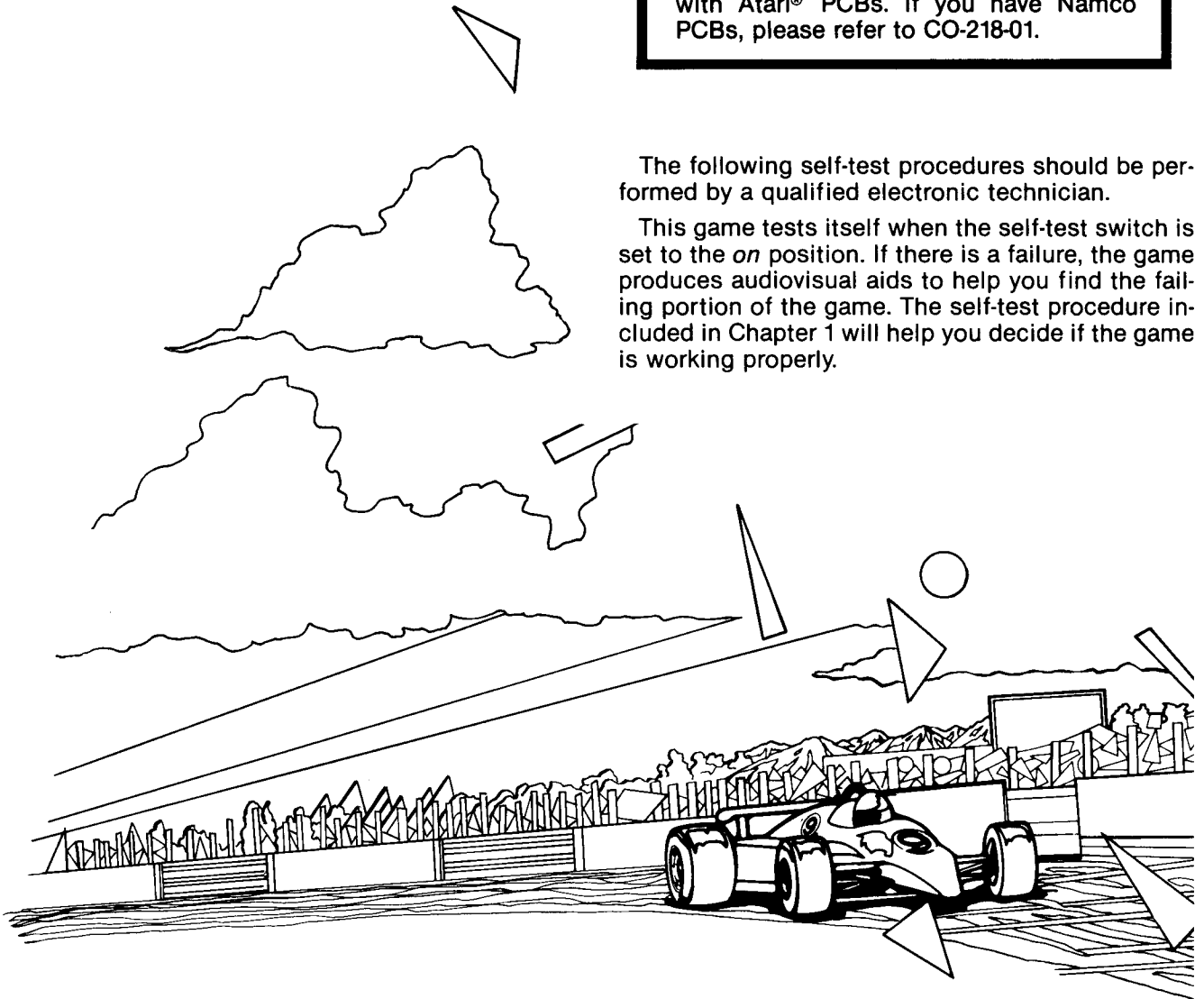

Chapter

2

A. Comments on Troubleshooting

When troubleshooting, first determine the symptom(s) of the failure. After determining the symptom, look over the wiring diagram and determine what assemblies could cause the failure. Could it be caused by the power supply, Regulator/Audio II printed-circuit board (PCB), or the video display?

The next step is to check all harness wires and connectors to the suspected assembly. If you do not find a harness or connector problem, substitute an assembly known to be good for the suspected failing assembly. If the game functions properly, you have successfully isolated the failure. If it doesn't, repeat the procedure with another assembly.

When you have isolated the failing assembly, you must troubleshoot that assembly and make the necessary repairs. If the video display fails, we suggest that a qualified video-display technician handle the troubleshooting and repair.

Be sure to refer to *The Book—A Guide to Electronic Game Operation and Servicing*, published by Atari, Inc., whenever you need help with the techniques, tools, and terminology associated with coin-operated electronic games.

To effectively troubleshoot a game PCB, learn as much as you can about the PCB. The diagrams in the *Schematic Package* (included with the game) show the functions of the circuitry. Again, while troubleshooting a PCB, first determine the symptom of the failure, then locate the suspected area on the schematic diagram. Tables 2-1 and 2-2 are troubleshooting aids, which can be used to locate faulty components.

Table 2-1 Locating Failed Components on the Video PCB

Symptom Area	PROM	Custom IC	RAM
Large Car Pictures		12J,13J	
Large Sign Pictures	12K,13K,12L,13L		
Small Cars & Signs	12N,13N		
All Cars & Signs	12H,11N	13H	9F,10F
Alphanumerics	7N,8M	8N	
Raceway	2L,2M,2N,4L	3N	
Background	6N,5K		
Raceway & Background		5L,6L	
Middle & Sides of Raceway	2B,2C,2D		
All Video		4D,7E,2F	
Red	11E		
Green	11D		
Blue	11C		

Table 2-2 Locating Failed Components on the CPU PCB

Symptom Area	PROM	Custom IC	RAM	A to D Converter
Audio				
Voice	9C	9D		
Screech/Crash		9E		
Player's Motor	12E,12F			
All Other Sounds	7L,11D		7K,7J	
Inputs				
Brake and/or Accelerator				8J
Steering		9K		
Option Switches		9K,9M		
All Other Inputs		9M		
Control for Audio & Inputs		8H,9H		
Sync		7M		
High Scores		7E		

B. Performing the Self-Test

This game will test itself and provide data to show that the game's circuitry and controls are operating properly. The data is provided on the video display and speaker. No additional equipment is necessary.

Video game repair should only be performed by a qualified electronic technician.

To begin the Self-Test Mode, set the self-test switch, which is located on the utility panel, to the on position.

CAUTION

Do not depress the accelerator or brake pedal when turning on the game or switching to the Self-Test Mode. This will cause faulty program initialization and incorrect action of the player controls.

SELF-TEST SCREEN 1—Test Passes:

Upright Cabinet. If the test passes, the screen displays the picture in Figure 2-1, Upright Test Passes. See *Chapter 1, Section G, Performing the Initial Self-Test* for a complete description of this picture. To see self-test screen two, set the self-test switch to *off* and immediately back to *on*.

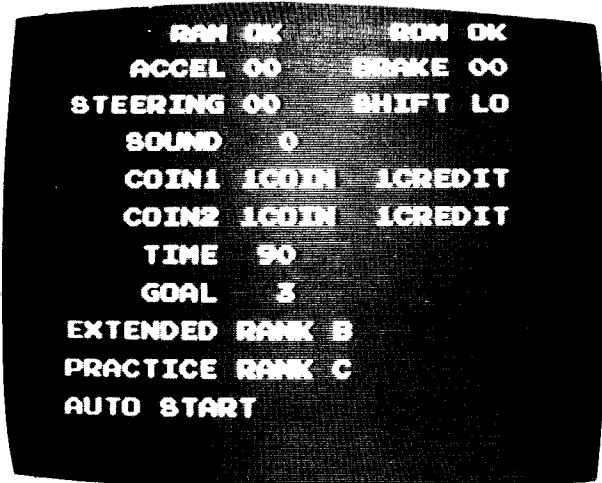

Figure 2-1 Self-Test Screen 1: Upright Test Passes

SELF-TEST SCREEN 1—Test Fails:

If the test fails, the screen may display the picture in Figure 2-3, Test Fails.

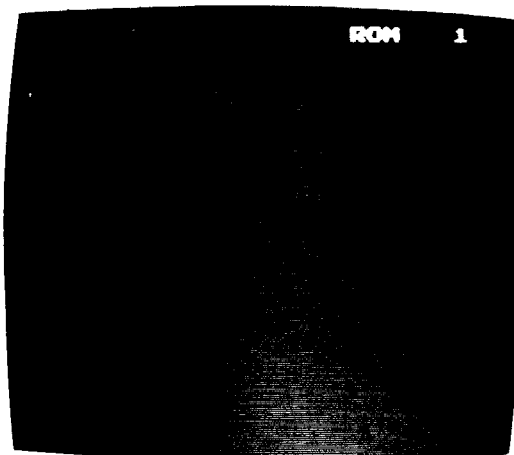

Figure 2-3 Self-Test Screen 1: Test Fails

ROM failure is indicated by the word *ROM* and a pair of alphanumeric characters displayed at the top of the screen.

Sit-Down Cabinet. If the test passes, the screen displays the picture in Figure 2-2, Sit-Down Test Passes. See *Chapter 1, Section G, Performing the Initial Self-Test* for a complete description of this picture. To see self-test screen two, set the self-test switch to *off* and immediately back to *on*.

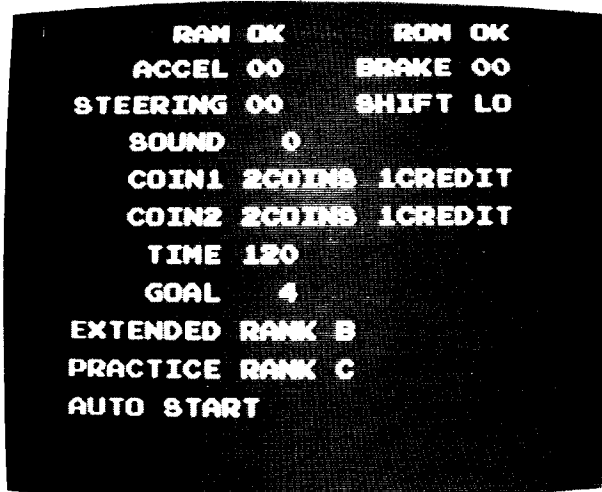

Figure 2-2 Self-Test Screen 1: Sit-Down Test Passes

Table 2-3 Locating the Failed ROM

ROM No.	Location on ATARI CPU PCB	Location on NAMCO CPU PCB
0	7H	6H
1	7F	5H
2	3L	8M
3	4L	8L
4*	3K	7M
5*	4K	7L
6	3E	4M
7	4E	4L
8*	3D	3M
9*	4D	3L

*Not used

RAM failure is indicated by the word *RAM* and a pair of alphanumeric characters displayed at the top of the screen. Table 2-4 lists the failed RAM chip, the printed-circuit board (PCB) the chip is on, and the chip's location.

Replace the failed RAM, and restart the test (set the self-test switch to *off*, and then to *on*).

NOTE

The reference designators for components in this chapter refer to games with Atari® PCBs. If you have Namco PCBs, please refer to CO-218-01.

Table 2-4 Locating the Failed RAM

RAM No.	Location on ATARI		Location on NAMCO	
	CPU PCB	Video PCB	CPU PCB	Video PCB
0, 20, 40		8F		7H
1, 21, 41		7F		7F
22, 42		8J		5H
23, 43		7J		5F
2, 24, 44		8H		6H
3, 24, 45		7H		6F
26, 45		8K		4H
27, 47		7K		4F
4, 28, 48		3F		7B
29, 49		4F		7C
5, 30, 50		3E		8B
31, 51		4E		8C
6	7J		7H	
7	7K		8H	
8	7E		4H	

Steering failure is indicated by failure of the numbers to the right of *STEERING* to properly increase or decrease. As you rotate the wheel clockwise, these numbers should increase; as you rotate the wheel counterclockwise, they should decrease. If the test fails, suspect the Coupler PCB.

Accelerator failure is indicated by failure of the numbers to the right of *ACCEL* to increase as you press down on the pedal. If no numbers appear, suspect a bad A-D converter on the CPU PCB or a mechanical problem on the foot pedal assembly. Troubleshoot using the information in *Chapter 3, Section B*, and the game schematics.

Brake failure on the *Sit-Down* cabinet is indicated by failure of the numbers to the right of *BRAKE* to change as you press down on the brake pedal. On the *Upright* cabinet, brake failure is indicated by anything other than *00* appearing to the right of *BRAKE*. If the test fails, suspect a bad switch, improper mechanical adjustment on the foot pedal assembly, or no ground on the brake edge-connector pin in the harness.

Gear-shifter failure is indicated by failure of the words to the right of *SHIFT* to change from *LO* (shifter up) to *HI* (shifter down) as you shift gears. If the test fails, suspect loose connector wires or a bad switch.

Sound failure is indicated by the absence of any sound when the coin switches or gear shifter are activated. Suspect a loose harness or connector wire, the volume control turned off, the custom audio I/O chip, or the Regulator/Audio II board. Troubleshoot using the game schematics.

To see self-test screen two, set the self-test switch to *off* and immediately back to *on*.

SELF-TEST SCREEN 2:

A white crosshatch pattern appears on the screen (see *Figure 2-4*). Use this pattern for convergence (see the raster-scan video display manual).

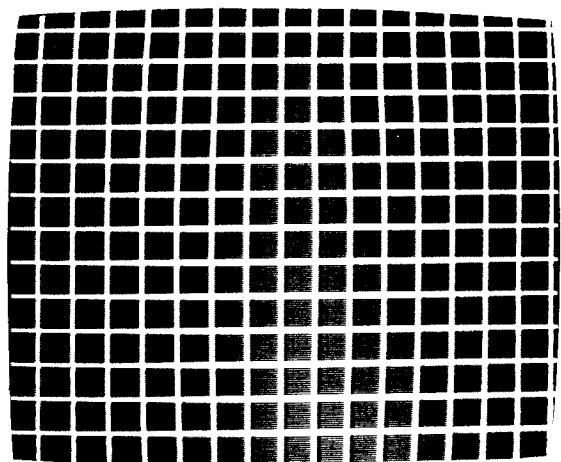

Figure 2-4 Self-Test Screen 2

Maintenance, Repair, and Parts

This chapter details maintenance and repair information and provides information you need to order parts for your game. Common hardware (screws, nuts, washers, bolts, etc.) has been deleted from most of the parts lists. However, a parts list for the hardware to mount the printed circuit boards (PCBs) to the cabinet has been included.

The printed circuit board (PCB) parts lists are arranged in alphabetical order by component. Each component subsection is sorted by reference designator. Other parts lists are arranged alphanumerically by Atari part number. In these parts lists, all A-prefix numbers come first. Following these are numbers in sequence evaluated up to the hyphen, namely 00- through 99-, then 000598-through approximately 201000-.

When ordering parts, please give the part number, part name, number of this manual, and serial number of your game. This will aid in filling your order rapidly and correctly. We hope the results will be less downtime and more profit from your game.

Atari Customer Service numbers are listed on the inside front cover of this manual.

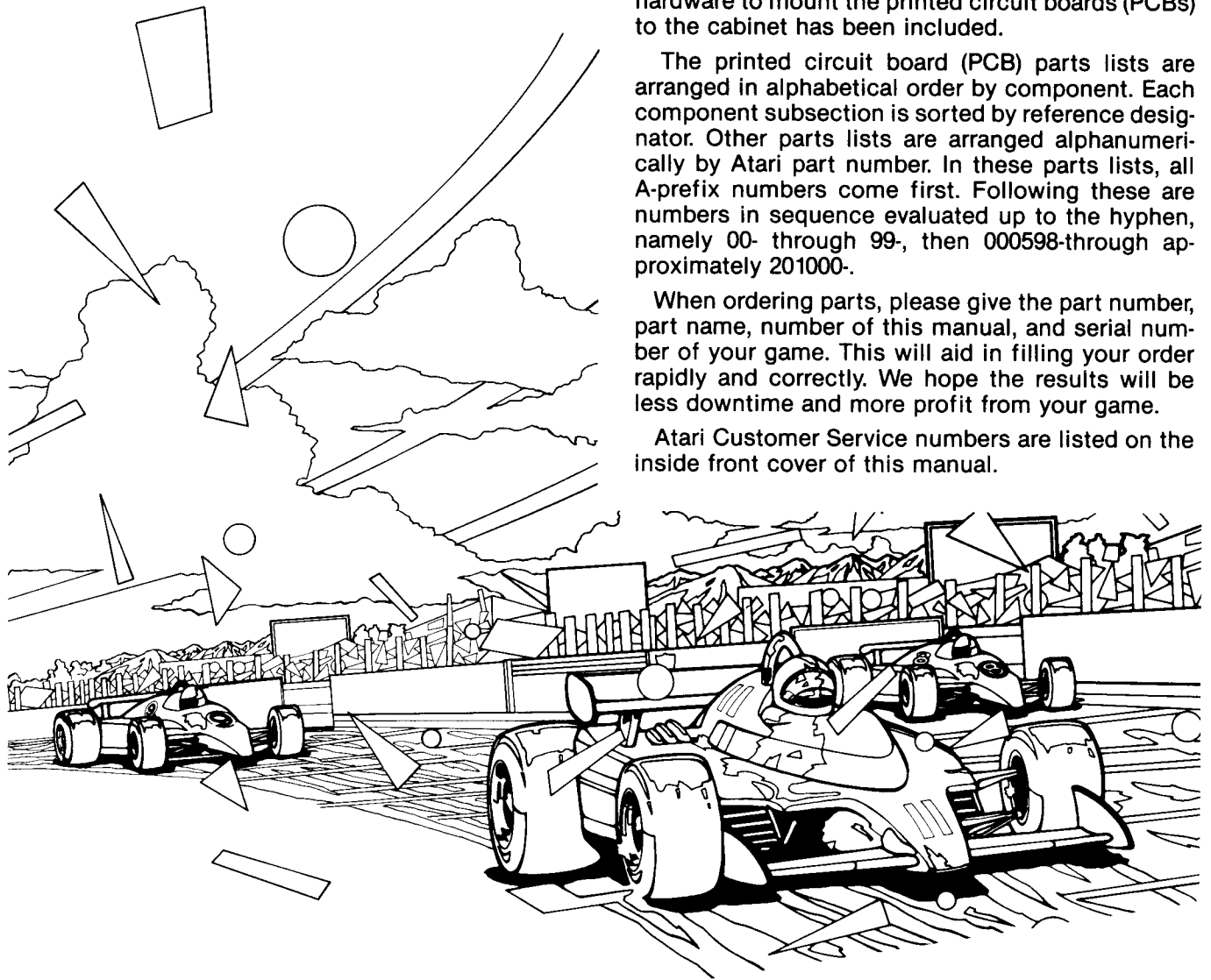

Chapter

3

A. Cabinet-Mounted Assemblies

Manuals, Schematics, & Self-Test Label—
See parts list on next page

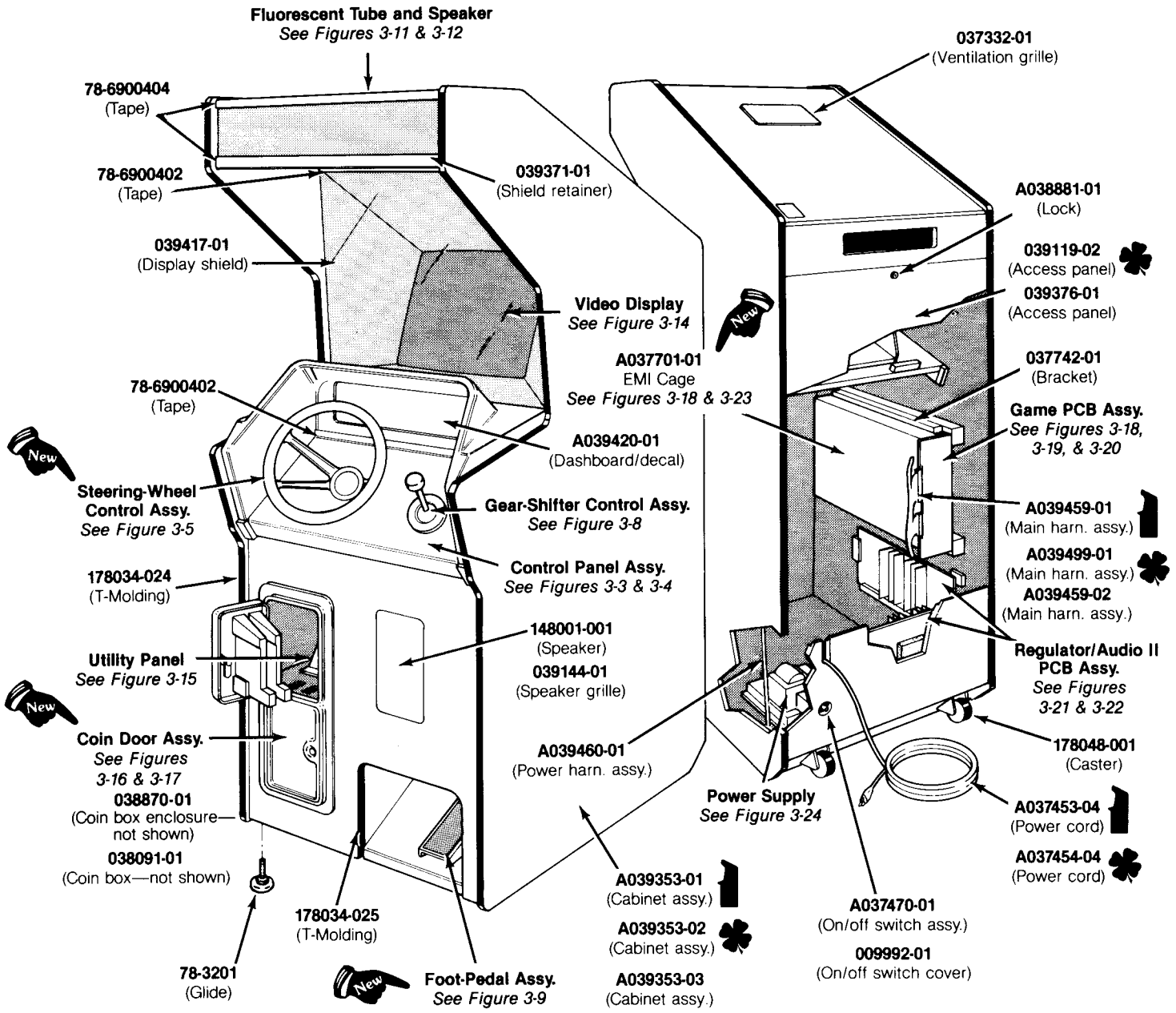

Figure 3-1 Cabinet-Mounted Assemblies
U.S.-Built Upright Cabinet A039352-01 H
Ireland-Built Upright Cabinet A039352-02 H

Cabinet-Mounted Assemblies Upright Cabinet Parts List

Assemblies and components in the following parts list are shown in Figure 3-1.

Part No.	Description
For U.S.-Built Upright Cabinet	
A037453-04	Strain-Relief Power Cord (U.S. and Canada)
A037701-01	Electromagnetic Interference Cage (includes guides)
A039353-01	Cabinet Assembly (includes glides and PCB retainers, but not access panel)
A039459-01	Main Harness Assembly (for U.S. PCB)
For Ireland-Built Upright Cabinet	
A037454-04	Strain-Relief Power Cord (Austria, Belgium, Chile, Denmark, Finland, France, Germany, Greece, Indonesia, Italy, Netherlands, Norway, Spain, Sweden, and Uruguay)
A039353-02	Cabinet Assembly (includes glides and PCB retainers, but not access panel) (for NAMCO PCB)
A039353-03	Cabinet Assembly (includes glides and PCB retainers, but not access panel) (for Atari® PCB)
A039459-02	Main Harness Assembly (for Atari® PCB)
A039499-01	Main Harness Assembly (for NAMCO PCB)
037742-01	Printed Circuit Board Mounting Bracket
039119-02	Rear Access Panel
72-1620S	#6-32 x 1.25-Inch Pan Head Machine Screw
75-016S	#6 Flat Washer
For U.S.-Built and Ireland-Built Cabinets	
A037470-01	Power On/Off Switch/Mounting Plate Assembly
A038881-01	Lock Assembly (for rear access panel) Acceptable substitute is part no. A038881-03
A039420-01	Dashboard Housing and Decal Assembly
A039460-01	Power Harness Assembly
A039576-01	Coin Option Interconnect Assembly
<i>The following nine items are technical information supplements to this game:</i>	
CO-218-01	Pole Position Supplement (for NAMCO game PCB removal)
SP-218	Pole Position Schematic Package (for Atari® game PCBs) or
SP-219	Pole Position Schematic Package (for NAMCO game PCBs)
ST-218-01	Pole Position Label with Self-Test Procedure and Option Switch Settings (for Atari® game PCBs)
ST-219-01	Pole Position Label with Self-Test Procedure and Option Switch Settings (for NAMCO game PCBs)
TM-160	Service Manual for 19-Inch Electrohome Color Raster-Scan Display (use with part no. 92-049)
TM-201	Service Manual for 19-Inch Wells-Gardner Color Raster-Scan Display (use with part no. 92-055)
TM-218	Pole Position Operation, Maintenance, and Service Manual
TM-220	Service Manual for 19-Inch Matsushita Color Raster-Scan Display (use with part no. 139003-1004)
78-3201	Adjustable Glide
78-6900402	Vinyl Foam Single-Coated Adhesive Tape, ¼-Inch Wide x ⅛-Inch Thick (48 inches required; used on top edge of video display shield, and on top edge of control panel)
78-6900404	Vinyl Foam Single-Coated Adhesive Tape, ¼-Inch Wide x ¼-Inch Thick (48 inches required; used on top and bottom of attraction panel)
009992-01	On/Off Switch Cover
037332-01	Ventilation Grille
038091-01	Molded Coin Box (not shown)
038770-01	Metal Coin Box Enclosure (not shown) Acceptable substitute is part no. 038781-01
039144-01	Speaker Grille
039371-01	Video Display Shield Retainer
039376-01	Rear Access Panel (does not include lock)
039417-01	Video Display Shield with Graphics
148001-001	6- x 9-Inch Oval, 4-Ohm, 15 W Unshielded High-Fidelity Speaker (located on front panel)
171034-xxx	Over/Under Coin Door Assembly Acceptable substitute is part no. 171027-001.
178034-024	¾-Inch Black Plastic T-Molding (located on side panels)
178034-025	⅝-Inch Black Plastic T-Molding (located on front panel)
178048-001	2-Inch Rigid Caster

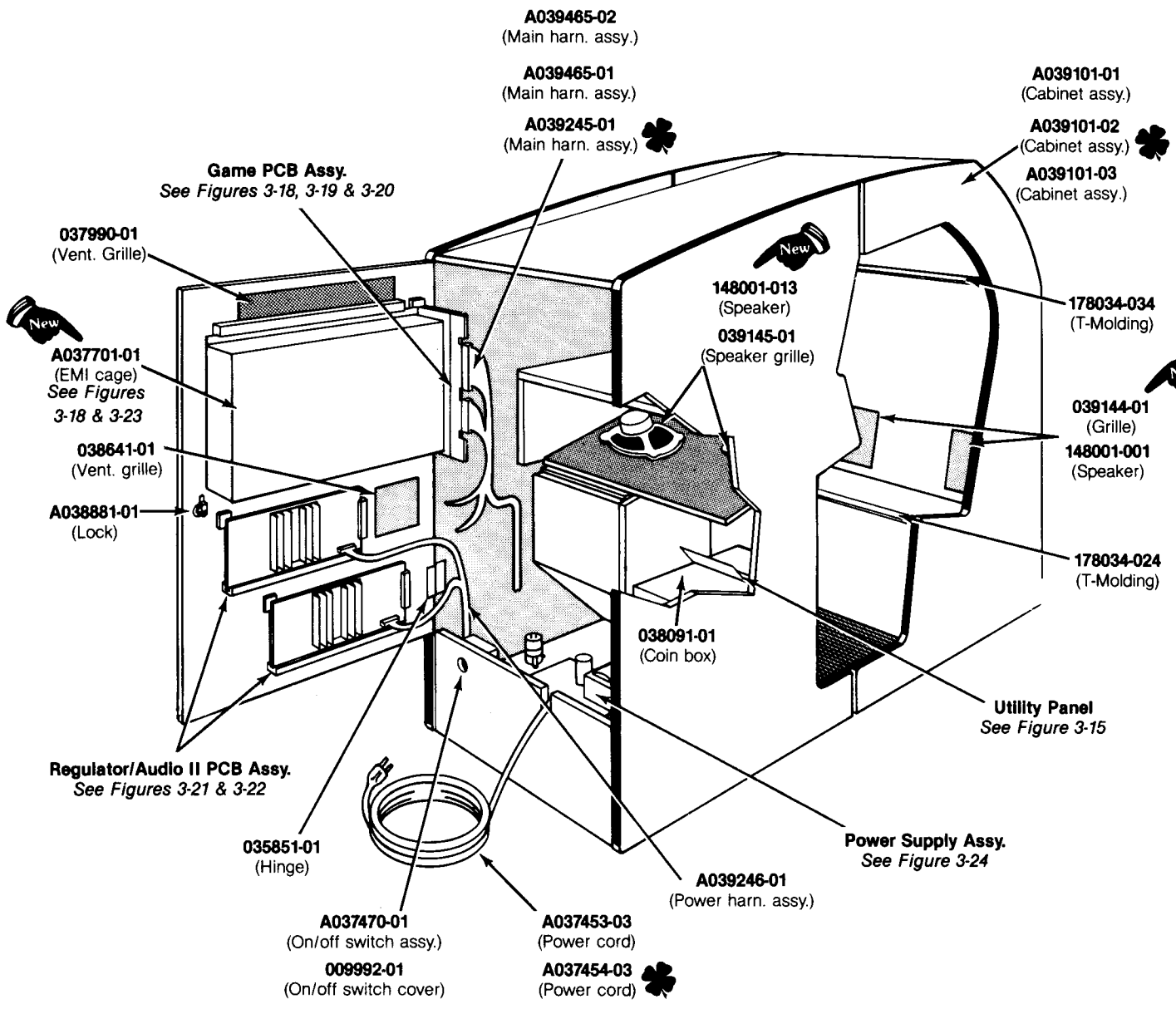

Figure 3-2 Cabinet-Mounted Assemblies
U.S.-Built Sit-Down Cabinet A039100-01 F
Ireland-Built Sit-Down Cabinet A039100-02 F

Manuals, Schematics, & Self-Test Label—
See parts list on next page

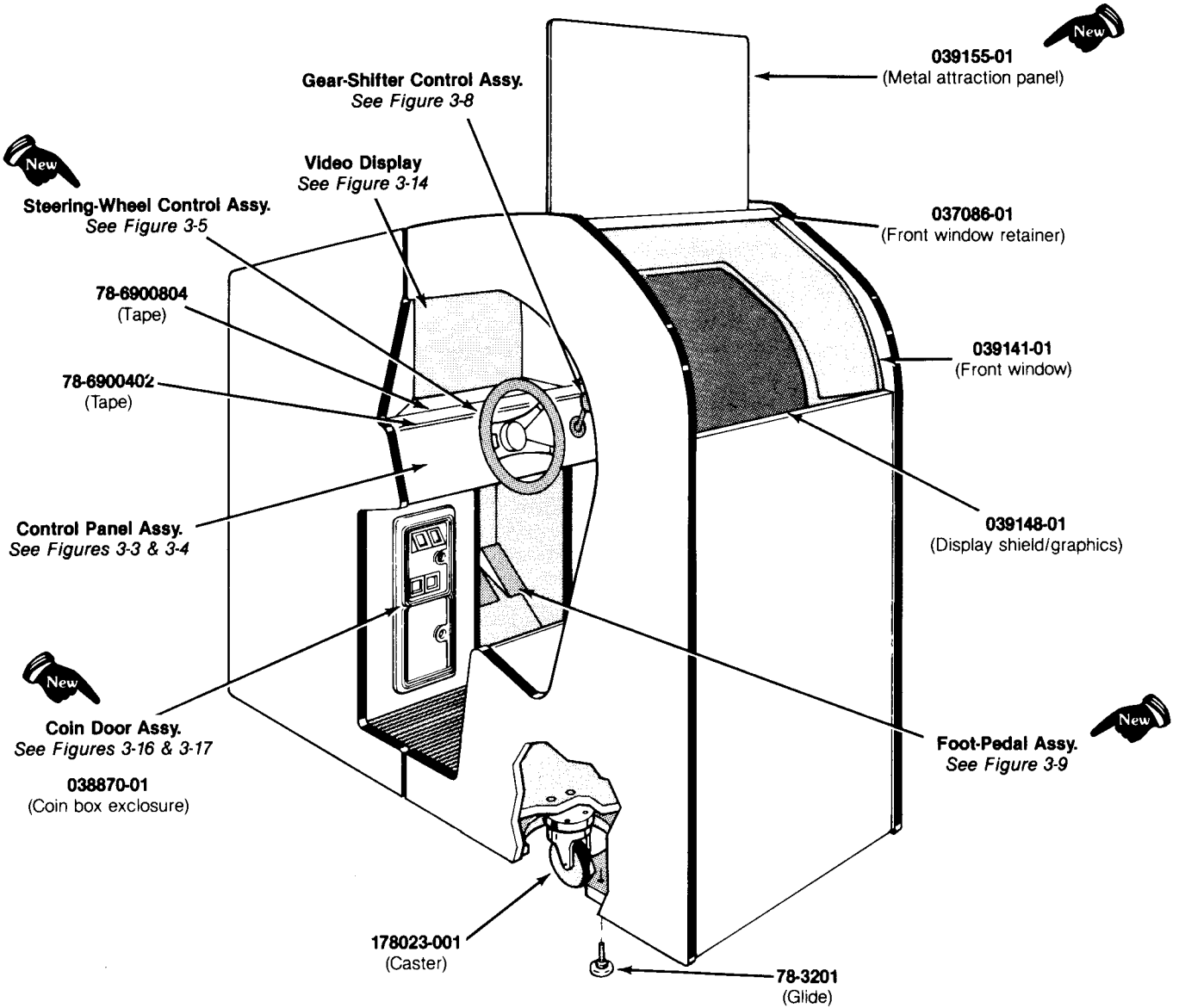

Figure 3-2 Cabinet-Mounted Assemblies, continued
U.S.-Built Sit-Down Cabinet A039100-01 F
Ireland-Built Sit-Down Cabinet A039100-02 F

Cabinet-Mounted Assemblies Sit-Down Cabinet Parts List

Assemblies and components in the following parts list are shown in Figure 3-2.

Part No.	Description
For U.S.-Built Cabinet	
A037453-03	Strain-Relief Power Cord (U.S. and Canada)
A037701-01	Electromagnetic Interference (EMI) Cage (includes guides)
A039101-01	Cabinet Assembly (includes glides and PCB retainers, but not the rear access panel)
A039465-01	Main Harness Assembly
For Ireland-Built Cabinet	
A037454-03	Strain-Relief Power Cord (Austria, Belgium, Chile, Denmark, Finland, France, Germany, Greece, Indonesia, Italy, Netherlands, Norway, Spain, Sweden, and Uruguay)
A039101-02	Cabinet Assembly (includes glides and PCB retainers, but not the rear access panel)
A039101-03	Cabinet Assembly (includes glides and PCB retainers, but not the rear access panel)
A039245-01	Main Harness Assembly (for NAMCO PCBs)
For U.S.-Built and Ireland-Built Cabinets	
A039246-01	Power Harness Assembly
A039465-02	Main Harness Assembly (for Atari® PCBs)
A037470-01	Power On/Off Switch/Mounting Plate Assembly
A038881-01	Lock Assembly (for rear access panel) Acceptable substitute is part no. A038881-03
107001-001	Flat Black Paint
The following nine items are technical information supplements to this game:	
CO-218-01	Pole Position Supplement (for NAMCO game PCB removal)
SP-218	Pole Position Schematic Package (for Atari® game PCBs) or
SP-219	Pole Position Schematic Package (for NAMCO game PCBs)
ST-218-01	Pole Position Label with Self-Test Procedure and Option Switch Settings (for Atari® PCBs) or
ST-219-01	Pole Position Label with Self-Test Procedure and Option Switch Setting (for NAMCO PCBs)
TM-160	Service Manual for 19-Inch Electrohome Color Raster-Scan Display (use with part no. 92-049)
TM-201	Service Manual for 19-Inch Wells-Gardner Color Raster-Scan Display (use with part no. 92-055)
TM-218	Pole Position Operation, Maintenance, and Service Manual
TM-220	Service Manual for 19-Inch Matsushita Color Raster-Scan Display (use with part no. 139003-1004)
72-1620S	#6-32 x 1.25-Inch Pan Head Machine Screw
72-5524	#1/4-20 x 1.50-Inch Hex Head Machine Screw
75-016S	#6 Flat Washer
75-045S	1/4-Inch Split-Lock Washer
78-3201	Adjustable Glide
78-6900402	Vinyl Foam Single-Coated Adhesive Tape, 1/4-Inch Wide x 1/8-Inch Thick (48 inches required; used on control panel)
78-6900804	Vinyl Foam Single-Coated Adhesive Tape, 1/2-Inch Wide x 1/8-Inch Thick (48 inches required; used in top slot of video display cleat, and on top and bottom of front window)
002728-01	Control-Panel Mounting Bracket
009992-01	On/Off Switch Cover
035851-01	Top Panel Hinge
037086-01	Front Window Retainer
037742-01	Printed Circuit Board Mounting Bracket
037990-01	Ventilation Grill (on rear access panel)
038091-01	Molded Coin Box (not shown)
038641-01	Ventilation Grille (on rear access panel)
038870-01	Metal Coin Box Enclosure Acceptable substitute is part no. 038781-01
039141-01	Front Window
039144-01	Speaker Grille (located behind seat)
039145-01	Speaker Grille (located under control panel)
039148-01	Video Display Shield with Graphics
039155-01	Metal Attraction Panel with Graphics
148001-001	6- x 9-Inch Oval, 4-Ohm, 15 W Unshielded High-Fidelity Speaker (not shown—located behind seat)
148001-013	6- x 9-Inch Oval, 4-Ohm, 15 W Shielded High-Fidelity Speaker (located under control panel)
171034-xxx	Over/Under Coin Door Assembly Acceptable substitute is part no. 171027-001
176015-110	#10 x 5/8-Inch Cross-Recessed, Pan-Head Tapping Screw (not shown—for mounting speakers/grilles to seat back)
178034-024	3/4-Inch Black Plastic T-Molding
178034-034	1-Inch Black Plastic T-Molding (located on seat back)
178023-001	4-Inch Rigid Caster

B. Player Controls

WARNING

Before you remove or repair any control on the control panel, turn the game off.

CAUTION

Before removing the final wing nut on the *Sit-Down* cabinet, hold the gear-shifter housing with one hand to prevent the front-heavy control panel from falling forward.

Opening the Control Panel:

1. Unlock and open the rear access panel (see *Figure 3-3*). Reach through the opening to the top of the control panel.
2. Remove the four wing nuts and washers that secure the control panel to the *Upright* cabinet. Two wing nuts and washers secure the control panel to the *Sit-Down* cabinet.
3. Guide or pull the control panel forward to its resting position. The steering wheel and gear shifter are now accessible for maintenance or repair (see *Figure 3-4*). Make sure the foam tape is in good condition. This tape is on the control panel of the *Upright* cabinet, and on the display shield for the *Sit-Down* cabinet.
4. Reassemble in reverse order.

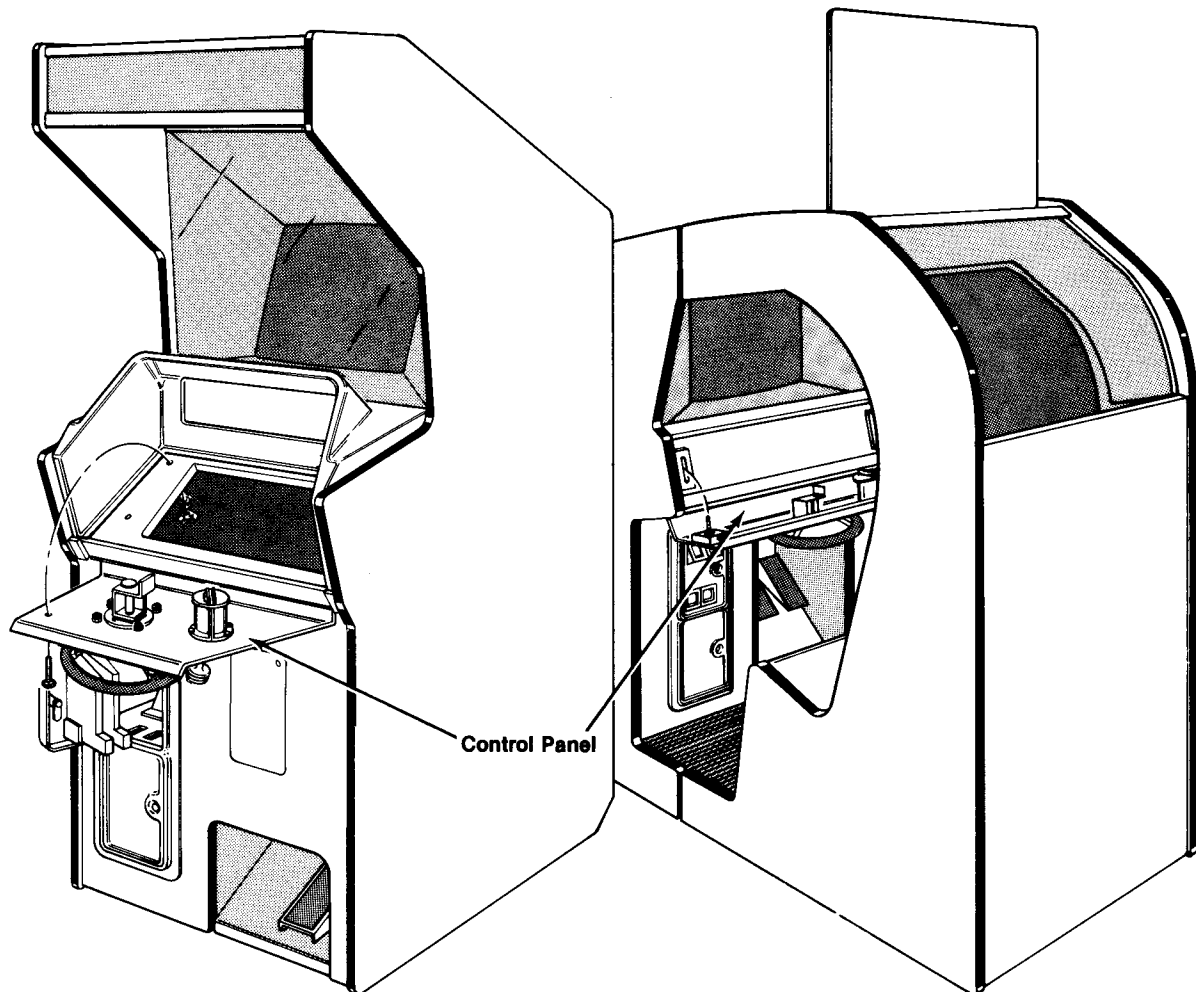
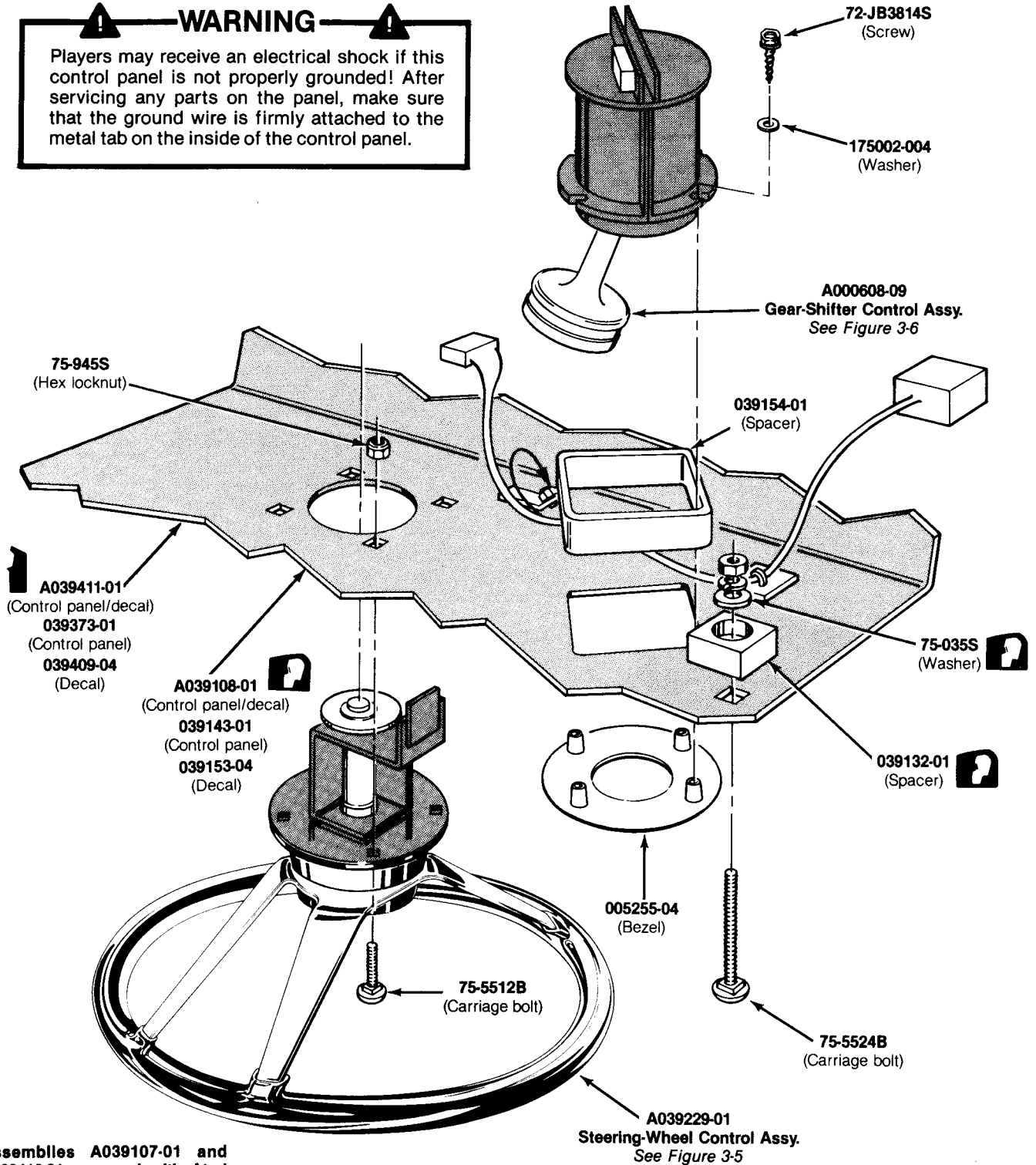

Figure 3-3 Control Panel

WARNING

Players may receive an electrical shock if this control panel is not properly grounded! After servicing any parts on the panel, make sure that the ground wire is firmly attached to the metal tab on the inside of the control panel.



Assemblies A039107-01 and A039412-01 are used with Atari game PCBs; Assemblies A039107-02 and A039412-02 are used with Namco game PCBs.

Figure 3-4 Control Panel Assembly
Upright Cabinet A039412-01 & -02 A
Sit-Down Cabinet A039107-01 & -02 B

Control Panel Assembly Parts List

Assemblies and components in the following parts list are shown in Figure 3-4.

<i>Part No.</i>	<i>Description</i>
<i>Upright Cabinet</i>	
A039411-01	Control Panel with Decal (<i>consists of control panel 039373-01 and decal 039409-04</i>)
177012-111	$\frac{7}{32}$ -Inch Push-On Spring Nut (<i>not shown</i>)
78-6900402	Vinyl Foam Single-Coated Adhesive Tape, $\frac{1}{4}$ -Inch Wide x $\frac{1}{8}$ -Inch Thick (<i>96 inches required</i>)
<i>Sit-Down Cabinet</i>	
A039108-01	Control Panel with Decal (<i>consists of control panel 039143-01 and decal 039153-04</i>)
039132-01	Control Panel Spacer
75-035S	$\frac{1}{4}$ -Inch Wide Flat Washer
75-5524B	# $\frac{1}{4}$ -20 x 1.50-Inch Black Carriage Bolt
<i>Upright and Sit-Down Cabinets</i>	
A039229-01	Steering-Wheel Control Assembly (<i>Namco games use part no. A039229-02</i>)
A000608-09	Gear-Shifter Control Assembly
72-JB3814S	#8-16 x .87-Inch Screw
75-5512B	# $\frac{1}{4}$ -20 x .75-Inch Black Carriage Bolt
75-945S	# $\frac{1}{4}$ -20 Hex Locknut
005255-04	Shifter Bezel
039154-01	Shifter Spacer
175002-004	#10 Flat Washer

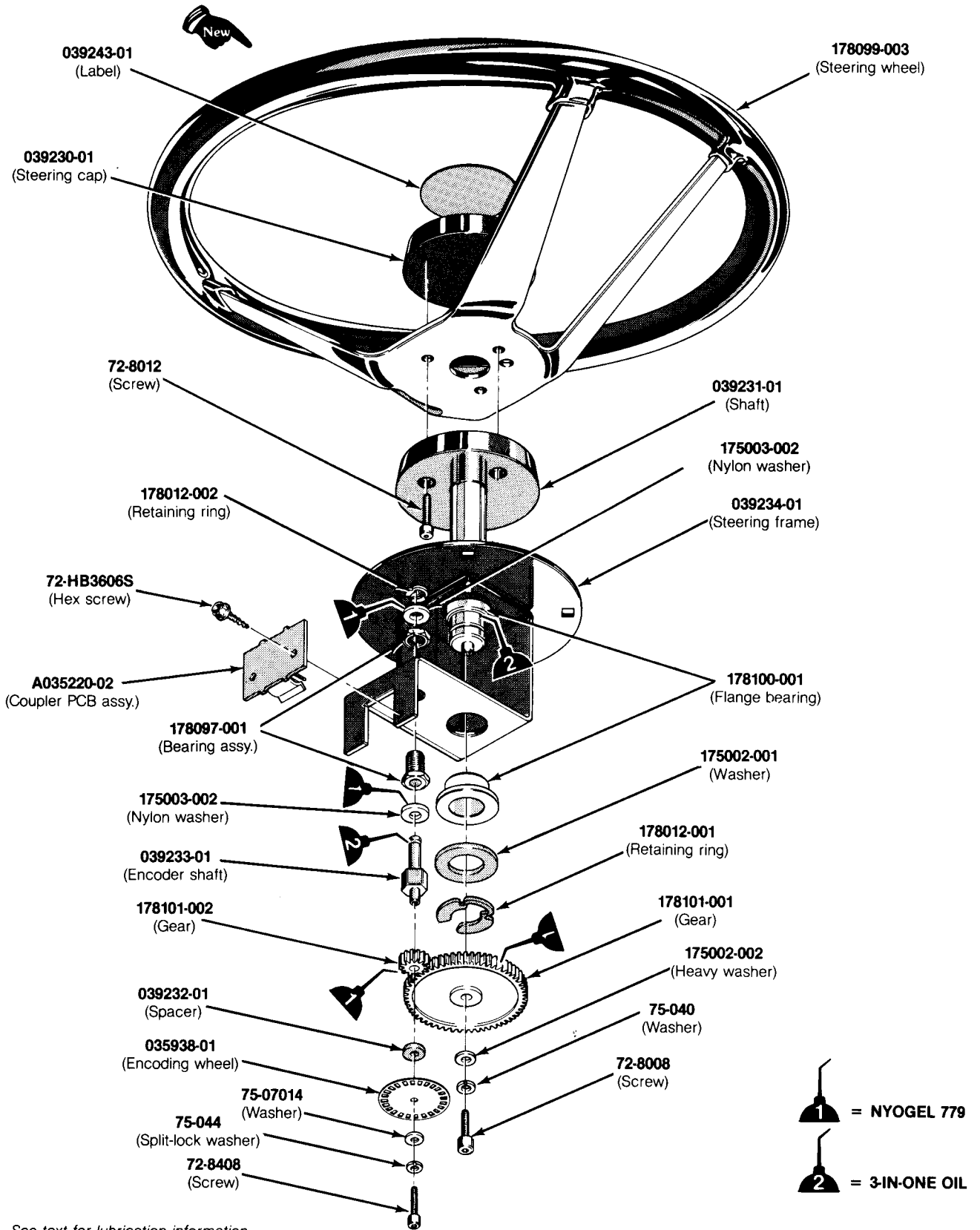

See text for lubrication information.

**Figure 3-5 Steering-Wheel Control Assembly
A039229-01 D**

Steering-Wheel Control Assembly Parts List

Assemblies and components listed in the following parts list are shown in Figure 3-5.

Part No.	Description
A035220-02	Coupler Printed-Circuit Board Assembly <i>(includes Radial Optical Coupler)</i>
72-8008	#10-32 x 0.50-Inch Steel Socket-Head Cap Screw
72-8012	#10-32 x 0.75-Inch Steel Socket-Head Cap Screw
72-8408	#4-40 x 0.50-Inch Steel Socket-Head Cap Screw
72-HB3606S	#6-32 x 0.38-Inch Zinc-Plated Steel Hex Washer-Head Screw
75-040	#10 Split-Lock Washer
75-044	#4 Split-Lock Washer
75-07014	#4 Flat Washer
79-58356	4-Position Connector with Locking Ramp <i>(located on the Coupler PCB Assembly)</i>
030369-01	Radial Optical Coupler <i>(located on the Coupler PCB Assembly)</i>
035221-01	100 Ω , $\pm 5\%$, 1/4W Resistor <i>(located on the Coupler PCB Assembly)</i>
039230-01	Steering Cap
039231-01	Steering Shaft
039232-01	Spacer
039233-01	Encoder Shaft
039234-01	Steering Frame
039243-01	Steering Cap Label
035938-01	Encoding Wheel
107013-001	3-in-One [®] Oil
175002-001	Flat Washer
175002-002	#10 Heavy Flat Washer
175003-002	Nylon Flat Washer
178012-001	Retaining Ring for 0.75-Inch Shaft
178012-002	Retaining Ring for 0.25-Inch Shaft
178027-001	Nyogel 779 Lubricant
178097-001	Bearing for 0.25-Inch Shaft
178099-003	Steering Wheel
178100-001	Bearing Flange for 0.75-Inch Shaft
178101-001	24 Diametral Pitch x 20° Pressure Angle x 2.500 Pitch Diameter Spur Gear
178101-002	24 Diametral Pitch x 20° Pressure Angle x 0.583 Pitch Diameter Spur Gear

WARNING

Before you remove or repair any player control, turn the game off.

Removing the Coupler PCB, Encoding Wheel, and Steering Wheel:

1. Open the control panel (see *Figure 3-3*).
2. To remove the steering-wheel control assembly, disconnect the green ground wire from the grounding hardware. Remove the hardware which secures the steering-wheel control assembly to the control panel (see *Figure 3-4*).
3. Unplug the harness connector on the Coupler PCB.
4. To remove the Coupler PCB, remove the hardware securing the PCB to the steering frame.
5. To remove the encoding-wheel assembly, hold the shaft of the encoding wheel in a fixed position with a wrench. Use an Allen wrench to remove the cap screw, encoding wheel, washers, spacer, and bearing. To remove the encoder shaft, pry off the retaining ring.
6. To remove the steering wheel, hold the steering wheel shaft in a fixed position. Remove the cap screw, washers, and gear. Pry off the retaining ring and remove the heavy washer.
7. Reassemble in reverse order.

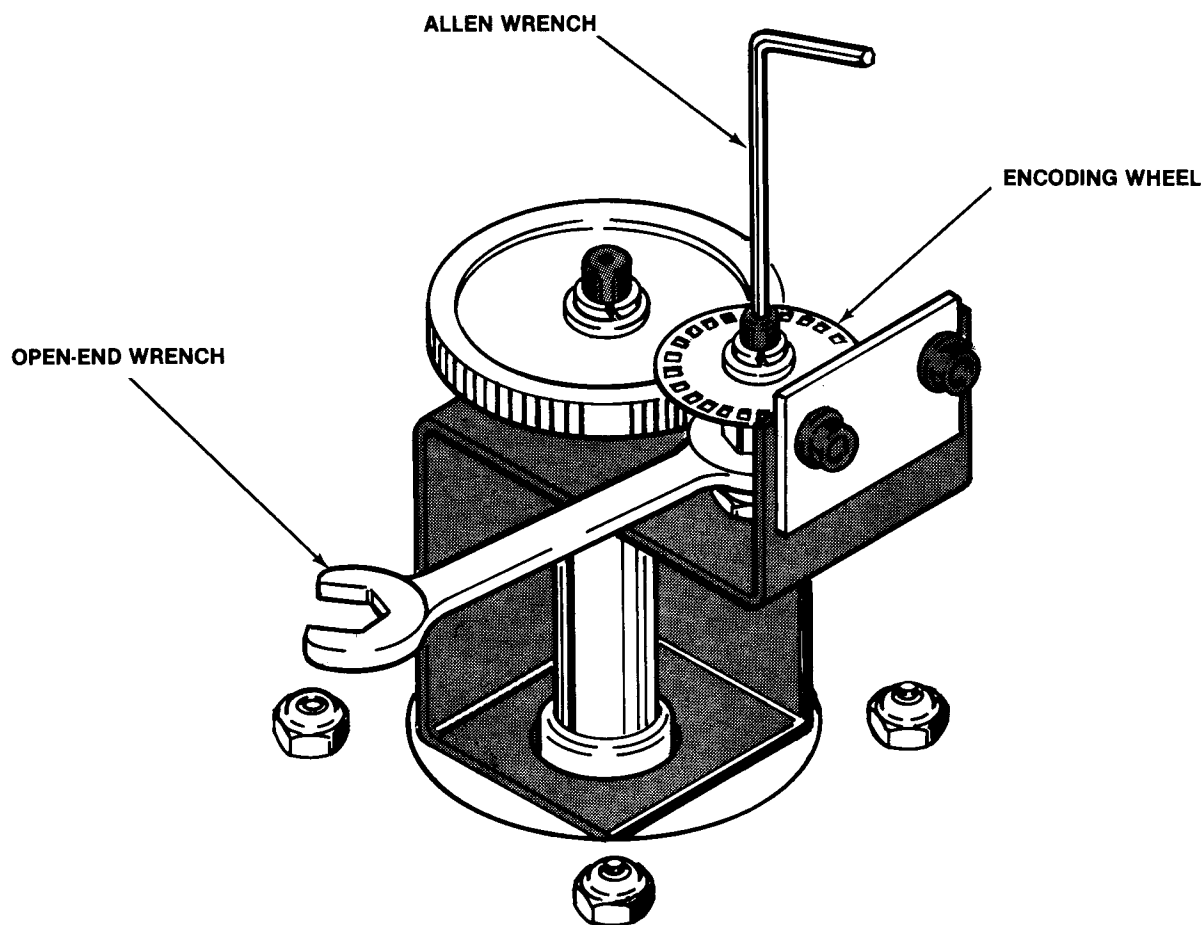

Figure 3-6 Steering-Wheel Control Screw Adjustment

Lubricating the Steering-Wheel Control:

Periodic maintenance of the steering-wheel control assembly must include the following procedures:

1. Check that the #4-40 x 1/2-inch socket-head cap screw (part no. 72-8408) on the encoder shaft is secure (see *Figure 3-6*). If the screw needs tightening, hold the encoder shaft (part no. 039233-01) with a 1/16-inch open-end wrench while tightening the screw with a 3/32-inch Allen wrench.
2. Check that the #10-32 x 1/2-inch socket-head cap screw (part no. 72-8008) on the steering-wheel shaft is tight (see *Figure 3-5*). If the screw needs tightening, hold the steering wheel still while using a 5/32-inch Allen wrench to tighten the screw.
3. Check, and if necessary, lubricate the encoder shaft (part no. 039233-01) and the two flat nylon washers (part no. 175003-002) as shown in *Figure 3-5*. Use ONLY the recommended lubricant, Nyogel 779 (part no. 178027-001). Nyogel 779 is a damping grease and will aid in the smooth operation of the control. Make sure a HEAVY film of this lubricant is applied to the encoder shaft and both surfaces of the nylon washers.
4. Check for a grinding feeling caused by inadequate lubrication or by the gears being too close together. To correct this condition, lubricate with Nyogel 779, and/or loosen the locknut on the bearing assembly (part no. 178097-001) and move the bearing away from the main steering shaft toward the coupler PCB assembly. This movement may be very small, but it can make a difference.
5. Check, and if necessary, lubricate the bronze flange bearings (part no. 178100-001) in the steering frame (part no. 039234-01), using a few drops of a light machine oil, such as 3-in-One oil (part no. 107013-001) (see *Figure 3-5*).
6. The steering-wheel control assembly should be positioned as follows (see *Figure 3-7*):
 - a. Open the control panel.
 - b. Disconnect the green ground wire from the grounding hardware. Remove the four carriage bolts that secure the steering-wheel control assembly to the control panel.
 - c. Rotate the steering-wheel control assembly 90° so that the encoding wheel assembly and the encoder shaft are on the bottom (nearest the floor). All new Pole Position games will be assembled in this manner.
 - d. Reinsert the four carriage bolts that secure the steering-wheel control assembly to the control panel. Reconnect the green ground wire.

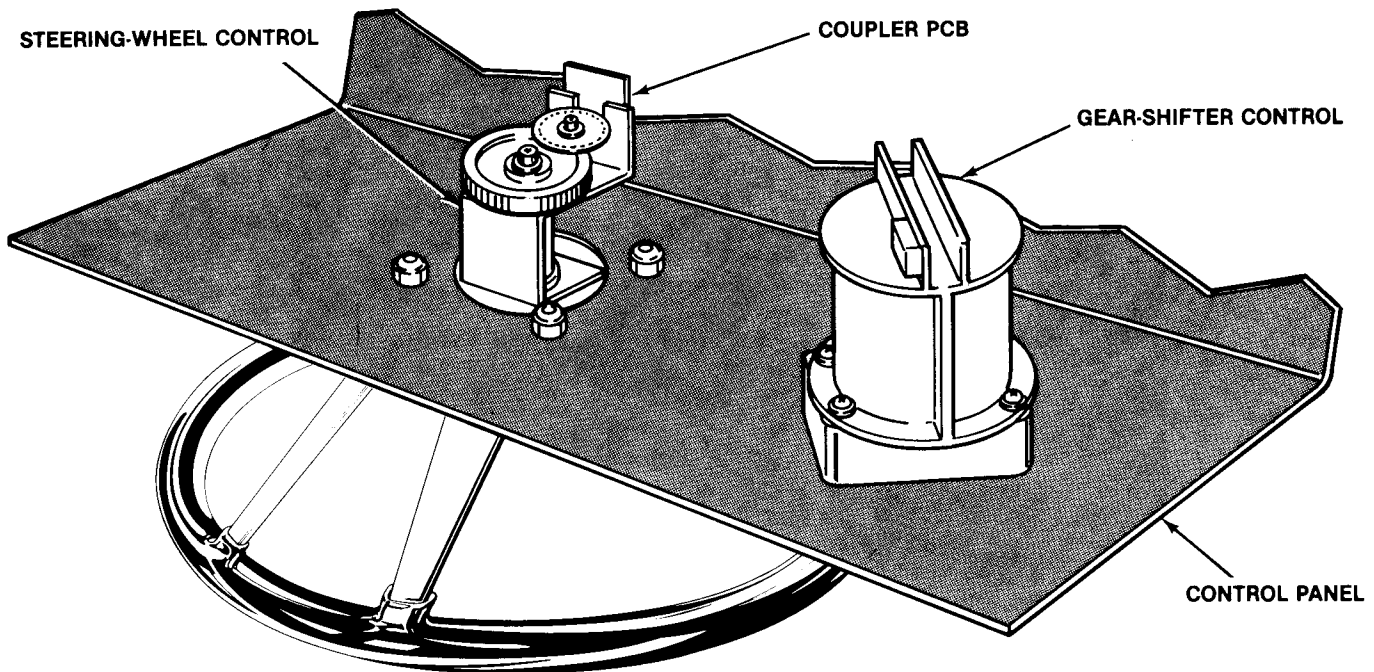
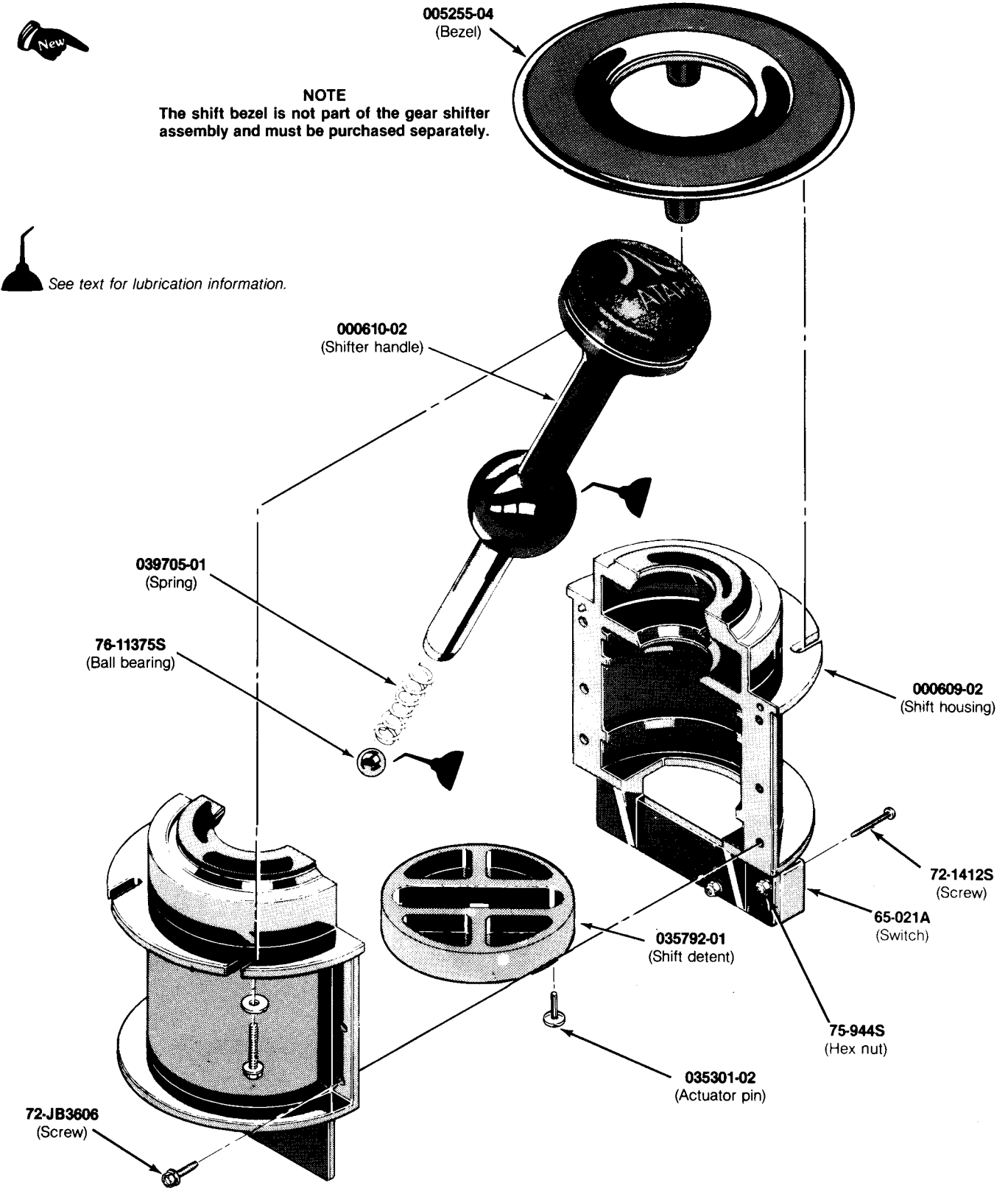

Figure 3-7 Steering-Wheel Control Orientation



**Figure 3-8 Gear-Shifter Control Assembly
A000608-09 AB**

WARNING

Before you remove or repair any player control, turn the game off.

4. To remove the switch, remove the two screws and locknuts that secure the switch to the housing. Be careful not to lose the small actuator pin that sits above the switch actuator.
5. Reassemble in reverse order.

Removing the Gear-Shifter Control Assembly:

1. Open the control panel (see *Figure 3-3*).
2. To remove the gear-shifter control assembly (see *Figure 3-4*), disconnect the plug-in connectors from the switch. Remove the hardware that secures the gear-shifter control assembly to the control panel.
3. To open the gear-shifter assembly, remove the six screws that secure the two halves of the housing (see *Figure 3-8*).

Lubricating the Gear-Shifter Control:

To lubricate the gear-shifter control assembly, open the control panel (see *Figure 3-3*) and remove the gear-shifter control assembly using the procedure above. Apply a light-duty lubricant (such as Nyogel 779) every six months to the spherical part of the handle and the detent.

Gear-Shifter Control Assembly Parts List

Assemblies and components listed in the following parts list are shown in *Figure 3-8*.

<i>Part No.</i>	<i>Description</i>
000610-02	Gear-Shifter Handle
65-021A	Single-Pole Single-Throw Low-Force Miniature Switch
72-JB3606	#6 x 0.38-Inch Steel Plastite Screw <i>Acceptable substitutes are part nos. 72-JB3608, 72-JA4608, and 72-JB16068</i>
72-1412S	#4-40 x 0.75-Inch Cross-Recessed Pan-Head Steel Machine Screw
76-11375S	$\frac{3}{8}$ -Inch Ball Bearing
75-944S	#4-40 Self-Locking Polymer Hex Nut
78-3002003	Spring
000609-02	Gear-Shifter Housing <i>(two required)</i>
005255-04	Shifter Bezel
035792-01	Shift Detent
035301-02	Actuator Pin
178027-001	Nyogel 779 Lubricant <i>(not shown)</i>

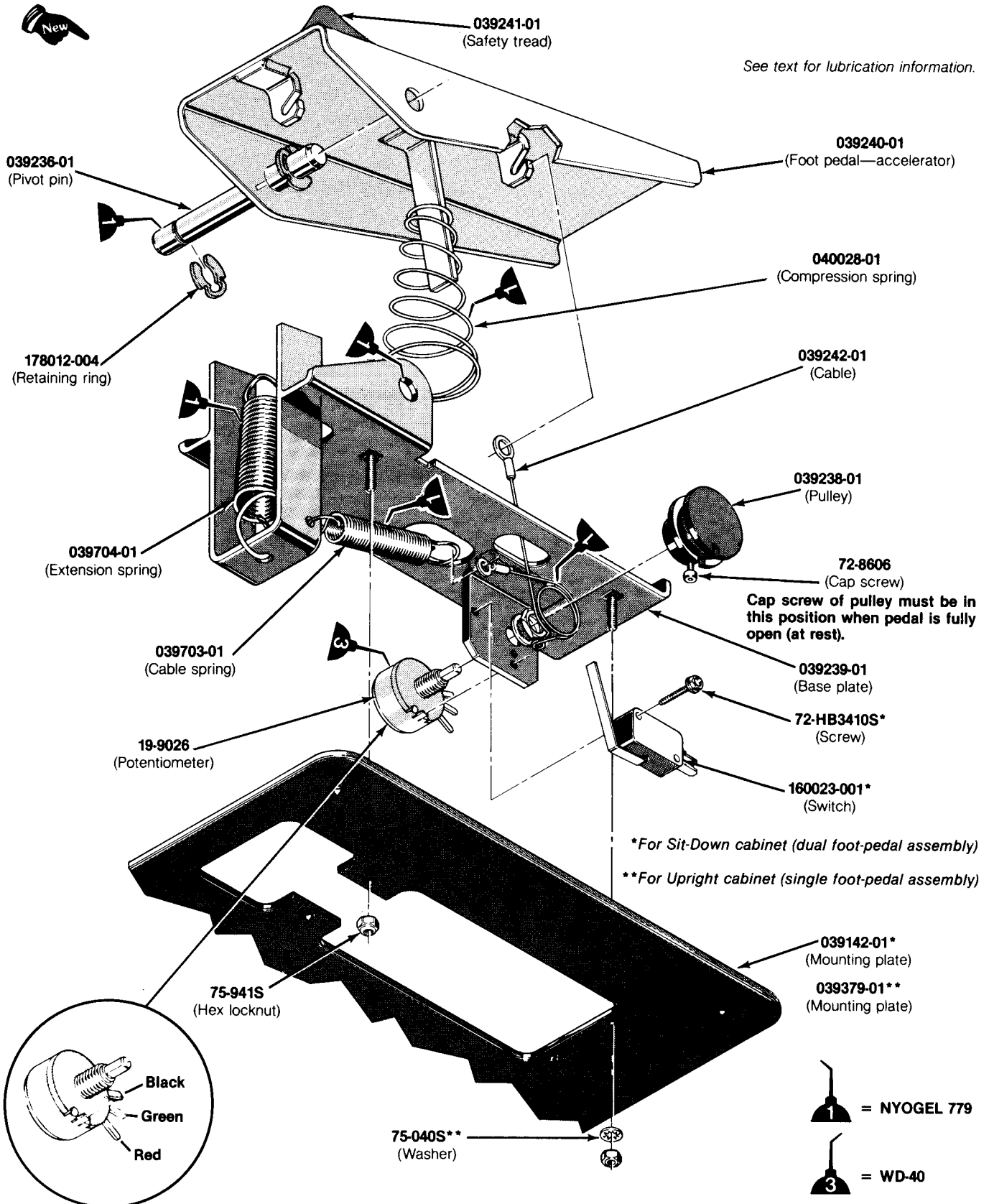

Figure 3-9 Foot-Pedal Control Assembly

Foot-Pedal Control Assembly
Upright A039413-01 B
Sit-Down A039109-01 C
Parts List

Assemblies and components in the following parts list are shown in Figure 3-9.

<i>Part No.</i>	<i>Description</i>
<i>Sit Down Cabinet</i>	
A039247-01	Dual Foot-Pedal Control Harness Assembly
72-HB3410S	#4-40 x .62-Inch Thread-Forming Hex Washer-Head Screw
75-010S	#10 Tooth Internal Lock Washer
160023-001	SPDT Snap Switch with Actuator
<i>Upright Cabinet</i>	
A039463-01	Single Foot-Pedal Control Pedal Harness Assembly
75-035S	1/4-Inch Flat Washer
75-040S	#10 Tooth Internal Lock Washer
75-5520B	#1/4-20 x 1.25-Inch Black Carriage Bolt <i>(not shown)</i>
75-915S	#1/4-20 Hex Nut
039379-01	Single Foot-Pedal Control Mounting Plate
<i>Upright and Sit-Down Cabinets</i>	
19-9026	5 k Ω Potentiometer
72-8606	#6-32 x .38-Inch Hex Socket-Head Cap Screw
75-941S	#10-24 Hex Locknut
040028-01	Compression Spring <i>(for pedal)</i>
039236-01	Pivot Pin
039238-01	Pulley
039239-01	Foot-Pedal Control Base Plate
039240-01	Foot Pedal
039241-01	Safety Tread
039242-01	Cable
107012-001	Dry Teflon Spray Lubricant <i>(not shown)</i>
178012-004	External Retaining Ring for 3/8-Inch Diameter Shaft
178026-005	Extension Spring <i>(for cable)</i>
178026-006	Extension Spring <i>(for pedal)</i>

**WARNING**

Before you remove or repair any player control, turn the game off.

Foot-Pedal Control Maintenance:**NOTE**

If the game fails to reach maximum speed, refer to Table 1-6 to make sure the option switch settings are set according to manufacturer's recommendations. If the switch settings are correct, perform the maintenance procedures set out below.

Removing the Foot-Pedal Control Assembly:

1. Unlock and open the rear access panel. Reach through the opening to the top of the foot-pedal control.
2. Remove the two locknuts located on the top two foot-pedal mounting screws.
3. From the front of the *Upright* cabinet or in the player area of the *Sit-Down* cabinet, remove the foot-pedal mounting screws and lift out the foot-pedal control assembly.

Periodic maintenance of the foot-pedal controls must include the following procedures:

1. The only maintenance required on this newly designed foot-pedal control is lubrication every four months (see *Figure 3-9*). **Lubricate** the pivot pin and surround-

1. Place the foot-pedal control assembly upside down on a work surface in front of you with the pedal in a fully open position and the hinged end away from you.

5. Wrap the cable one quarter-turn around the pulley and bring it out through the notch toward the cap screw.

4. Thread the cable up through the opening in the base plate.

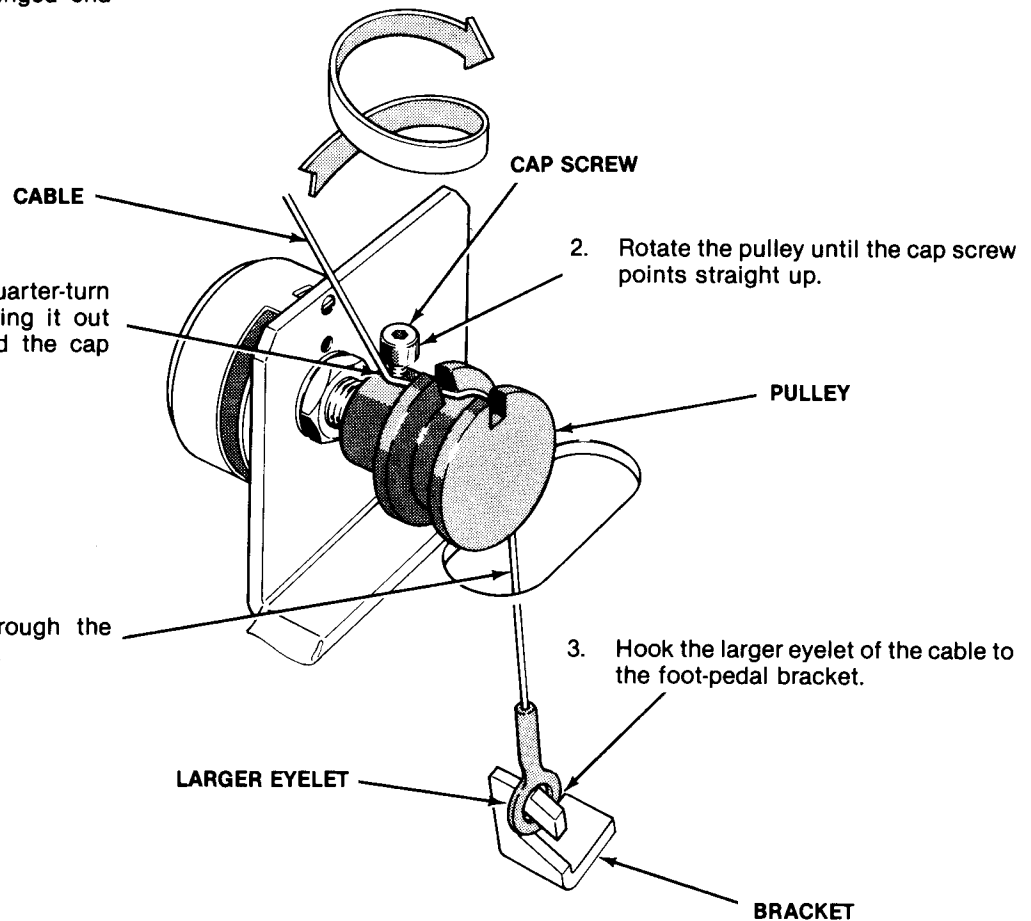

Figure 3-10 Foot-Pedal Pulley Cable Rewinding

- ing area, the spring cable, and pulley with dry teflon spray. If needed, apply a light-duty lubricant like WD-40 to the potentiometer shaft **only**.
2. If your accelerator pedal fails to return to its uppermost position, check for the following conditions:
 - a. Inadequate lubrication of the pedal assembly. Lubricate as necessary.
 - b. A broken extension spring (part no. 039704-01). Replace if necessary.
 - c. A broken or inadequately lubricated compression spring (part no. 000592-01). Replace and/or lubricate if necessary.
 - d. Inadequate lubrication of the potentiometer shaft (part no. 19-9026). Lubricate as necessary with a light-duty lubricant, such as WD-40 (part no. 78-1701).
 3. If the pulley cable needs rewinding, adjust as shown in *Figure 3-10*.

NOTE

If it is necessary to disassemble the foot-pedal control assembly and remove the pulley cable (part no. 039242-01), MAKE SURE the cable is wound as illustrated in *Figure 3-10*. BE CAREFUL not to cut or fray the cable in the disassembly/assembly process. Note that the foot-pedal assembly must be removed from the game cabinet in order to wrap the cable correctly.

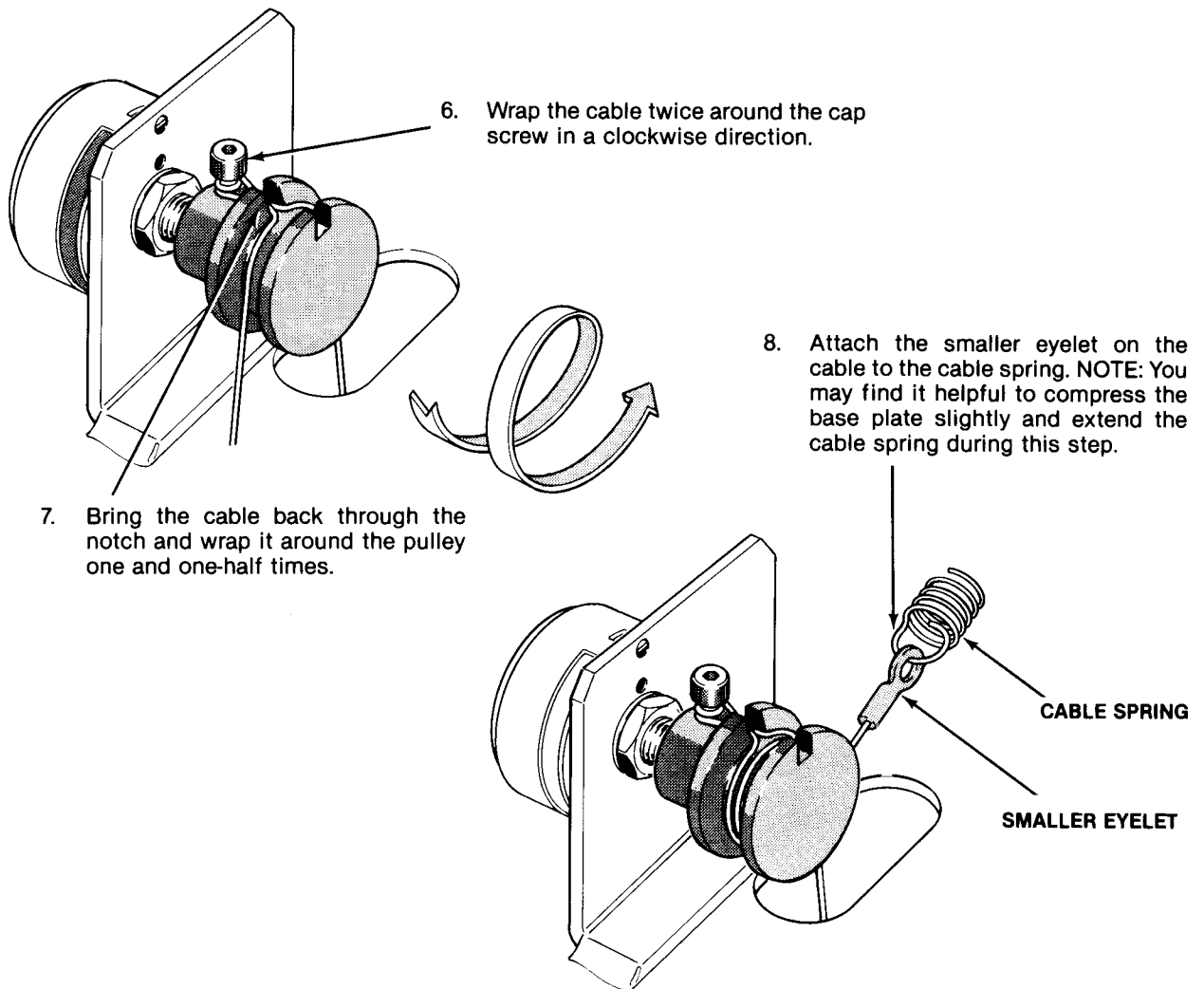

Figure 3-10 Foot-Pedal Pulley Cable Rewinding, continued

C. Fluorescent Tube and Speaker Replacement

WARNING

Before you remove or repair the fluorescent tube or speaker, **turn the game off.**

If you drop a fluorescent tube and it breaks, *it will implode!* Shattered glass can fly six feet or more from the implosion. Use care when replacing any fluorescent tube.

Upright Cabinet

Removing the Tube and Speaker Board:

1. From the back of the game, unlock and open the rear access panel. Unplug the tube and speaker's 5-pin harness connector (see *Figure 3-11*).
2. From the front of the game, remove the three button-head screws and lock washers that secure the upper attraction-panel retainer to the cabinet. Loosen the screws and washers that secure the lower attraction-panel retainer to the cabinet.
3. Remove the attraction glass.
4. Remove the lower retainer.

5. Remove the two wood screws that secure the tube and speaker board to the cabinet. Slide this board out of the cabinet. After making necessary repairs or replacements, make sure that the tube and speaker board is pushed all the way back on the tube and speaker panel when you reinstall the board.

Replacing the Fluorescent Tube:

1. Check that the green ground wire is securely attached to the large metal bracket and the ballast transformer on the wood panel. If the tube is not grounded, it may not start.
2. Remove the cardboard locking tab at each end of the tube (see *Figure 3-12*). Slightly rotate the tube up or down and carefully remove it from the tube holder.
3. Replace it with a new tube. Do not snap in the tube vigorously— *you may break it, causing an implosion!* Replace the locking tabs.

Replacing the Upper Speaker:

4. Disconnect the two plug-in connectors on the speaker. Note that the white wire (+) connects on the side marked with a painted dot.
5. Remove the screws that attach the speaker to the board (see *Figure 3-12*). Replace with a new speaker and reinstall the tube and speaker board.

Replacing the Lower Speaker:

From the back of the game, unlock and open the rear access panel. Refer to upper speaker removal procedure in *Figure 3-12*.

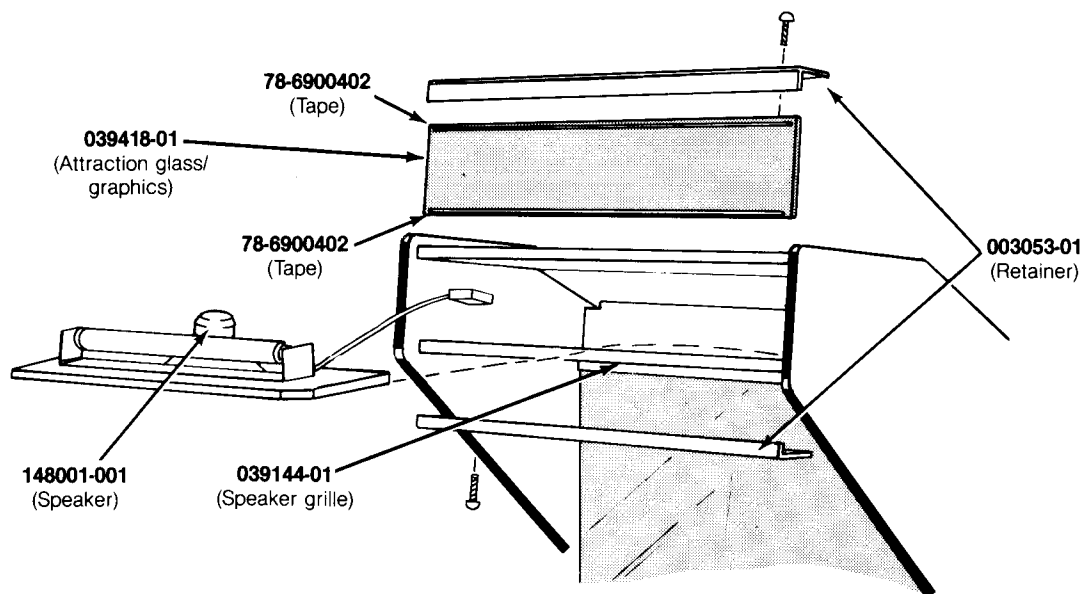
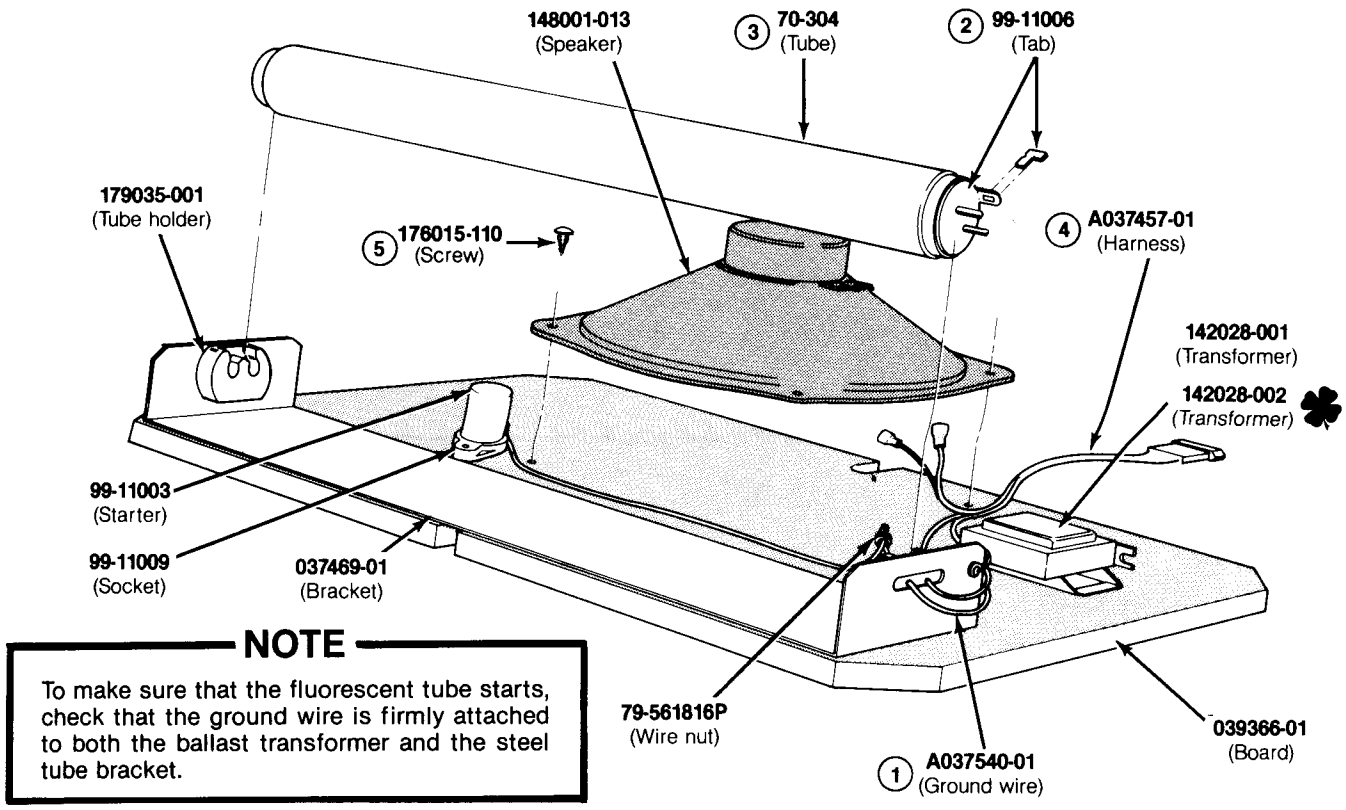

Figure 3-11 Fluorescent Tube and Speaker Board Removal Upright Cabinet



NOTE

To make sure that the fluorescent tube starts, check that the ground wire is firmly attached to both the ballast transformer and the steel tube bracket.

Figure 3-12 Fluorescent Tube and Speaker Board Assembly
U.S.-Built Upright Cabinet A039415-01 A
Ireland-Built Upright Cabinet A039415-02 A
Parts List

Part No.	Description
For U.S.-Built Upright Cabinet	
142028-001	60 Hz, 118 V, Ballast Transformer (used on A037458-01 assembly)
For Ireland-Built Upright Cabinet	
142028-002	50 Hz, 118 V, Ballast Transformer (used on A037458-02 assembly)
For U.S.- and Ireland-Built Upright Cabinet	
A037457-01	Tube and Speaker Harness Assembly
A037540-01	Ground Wire with Ring Lug
70-304	18-Inch, 15 W, Cool White Fluorescent Tube
78-6900402	Vinyl Foam Single-Coated Adhesive Tape, ¼-Inch Wide x ⅛-Inch Thick
79-561816P	Spring-Connector Wire Nut for 16- to 18-Gauge Wires
99-11003	Fluorescent Tube Starter
99-11006	Fluorescent Tube Locking Tab (tab consists of two pieces)
99-11009	Starter Socket
003053-01	Upper and Lower Attraction Glass Retainer
037469-01	Steel Tube Bracket
039366-01	Tube and Speaker Board
039418-01	Attraction Glass with Graphics
148001-013*	6 x 9-Inch Oval, 4-Ohm, 6-Ounce, Shielded High-Fidelity Speaker
176015-110	#10 x 5/8-Inch Pan Screw
179035-001	2-Pin Fluorescent Tube Holder

*148001-001 6 x 9-Inch Oval, 4-Ohm, 6-Ounce, High-Fidelity Speaker—mounted to the cabinet near the coin door, behind speaker grille part no. 039144-01

Sit-Down Cabinet

Replacing the Front Speakers:

1. For the right speaker, unlock and open the rear access panel (see *Figure 3-13*). For the left speaker, open the control panel (see *Figure 3-3*).
2. Unplug the two plug-in connectors.
3. Remove the two screws that secure the speaker to the wood speaker panel.

Replacing the Seat-Panel Speakers:

4. Remove the six wood screws that secure the seat-back panel to the cabinet (see *Figure 3-13*).
5. Lean the seat-back panel forward. Disconnect the two plug-in connectors on each speaker.
6. Remove the seat-back panel from the player area of the cabinet.
7. Remove the four screws that secure each speaker to the seat-back panel.
8. Reassemble in reverse order.

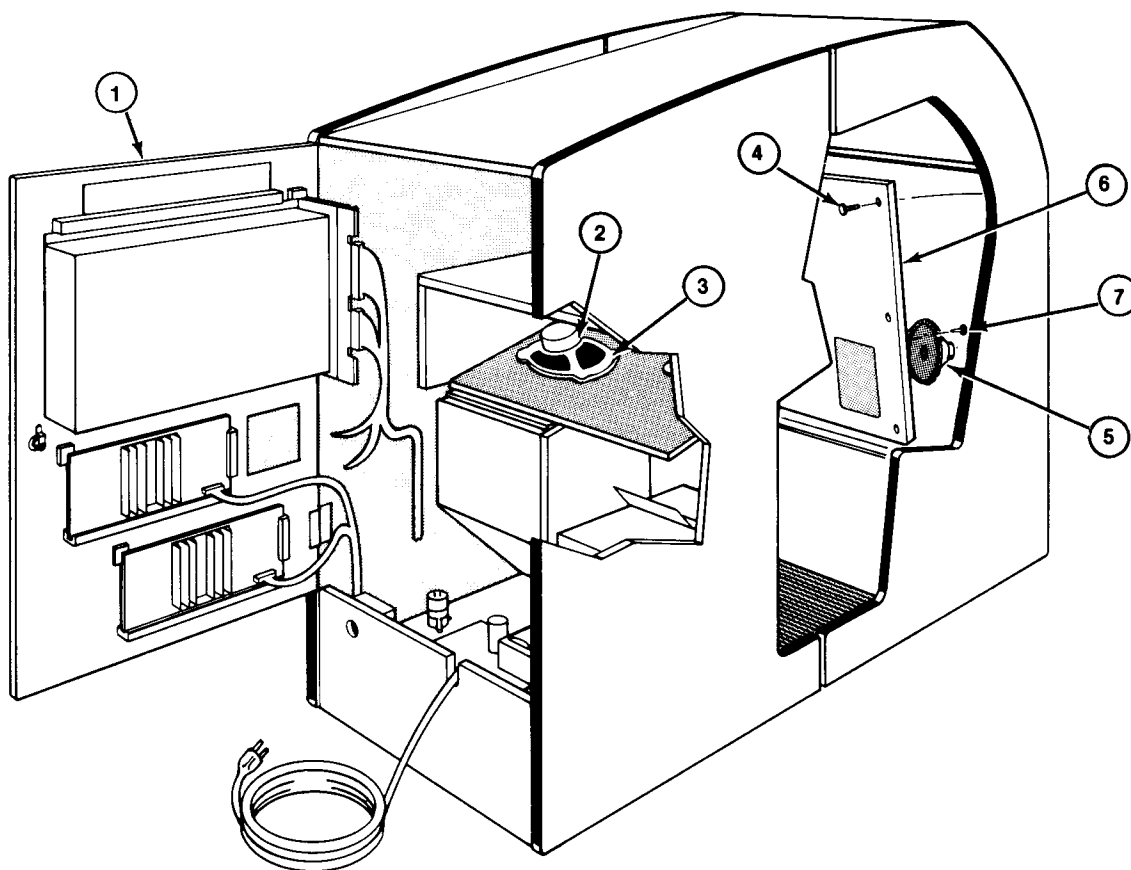

Figure 3-13 Sit-Down Cabinet Speaker Removal

D. Video Display

WARNING SHOCK HAZARD

The following procedure should only be performed by a *qualified service technician*. Before removing or repairing the video display, **turn the game off**.

High voltages may exist in any video display, even with power disconnected. Use extreme caution and do not touch electrical parts of the display yoke area with your hands or with metal objects in your hands!

Discharge the high voltage from the cathode ray tube as follows: First, attach one end of a large, well-insulated, 20-kV jumper to ground. Momentarily touch the free end of the grounded jumper to the anode by sliding it under the anode cap. Then, wait two minutes and discharge the anode again.

IMPLOSION HAZARD

If you drop the display and the picture tube breaks, *it will implode!* Shattered glass and the yoke can fly six feet or more from the implosion. Use care when replacing any display.

Removing the Video Display From the Sit-Down Cabinet:

1. From the back of the cabinet, unlock and open the rear access panel. Unplug the 6-pin connector from the video chassis, the 2-pin 110-VAC connector, and disconnect the ground wire (see *Figure 3-14*).
2. Remove the four sets of hardware that secure the video display to the wood display shelf.
3. Open the control panel (see *Figure 3-3*).
4. Move to the player area of the cabinet. Grasp the bottom edge of the video display shield and slide the shield out and down. Make sure the foam tape on the bottom of the shield is in good condition.
5. Remove any staples that may secure the bezel to the cabinet. Then, carefully grasp the bottom edge of the cardboard bezel and remove it from the cabinet.
6. Pull the display out through the front of the cabinet. Place the display in a protected location. After servicing the display, reinstall in reverse order.

Removing the Video Display From the Upright Cabinet:

1. From the back of the cabinet, unlock and open the rear access panel. Unplug the 6-pin connector from the video chassis, the 2-pin 110-VAC connector, and disconnect the ground wire (see *Figure 3-14*).
2. Remove the four sets of hardware that secure the video display to the wood display shelf.
3. Open the control panel (see *Figure 3-3*).
4. Remove the three wing nuts (located on the display-shield support) that secure the dashboard panel to the cabinet.
5. From the front of the cabinet, lift off the dashboard panel.
6. Remove the hardware that secures the display-shield retainer. Lift the display shield up and out of the cabinet.
7. Remove any staples that may secure the bezel to the cabinet. Then, carefully remove the cardboard bezel.
8. **Carefully** pull the display out through the front of the cabinet. Place the display in a protected location. After servicing the display, reinstall in reverse order.

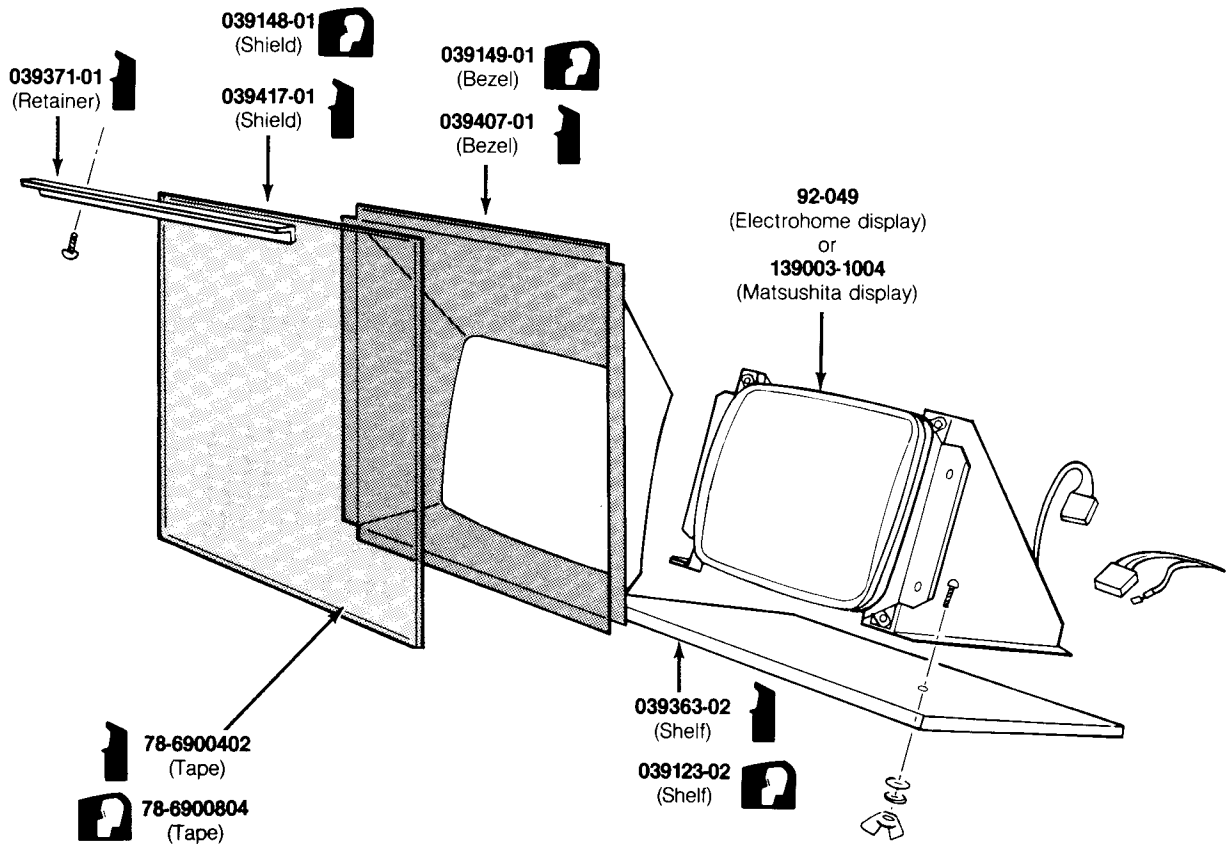

Figure 3-14 Video Display Upright and Sit-Down Cabinets Parts List

Part No.	Description
For Upright Cabinet	
039363-02	Display Shelf
039371-01	Retainer
039407-01	Display Bezel
039417-01	Display Shield
78-6900402	Vinyl Foam Single-Coated Adhesive Tape, 1/4-Inch Wide x 1/8-Inch Thick
For Sit-Down Cabinet	
039123-02	Display Shelf
039148-01	Display Shield
039149-01	Display Bezel
78-6900804	Vinyl Foam Single-Coated Adhesive Tape, 1/2-Inch Wide x 1/8-Inch Thick
For Upright and Sit-Down Cabinets	
92-049	19-Inch Electrohome Color Raster-Scan Display <i>Alternate display is part no. 139003-1004—19-Inch Matsushita Color Raster-Scan Display</i>

E. Utility Panel

WARNING

Before removing or repairing the utility panel, turn the game off.

Players may receive an electrical shock if the utility panel is not properly grounded! After servicing any parts on the panel, make sure that the ground wire is firmly attached to the metal screw on the back of the coin counter.

The utility panel is located inside the upper coin door. This panel includes the volume control(s), self-test switch, auxiliary coin switch, and the coin counter(s) (see Figure 3-15). The auxiliary coin switch is used to credit the game without tripping the coin counter.

NOTE

Only Ireland-Built cabinets have two coin counters. If using both coin counters, the pad at 10D (pins 11 and 12) on the CPU PCB must be split.

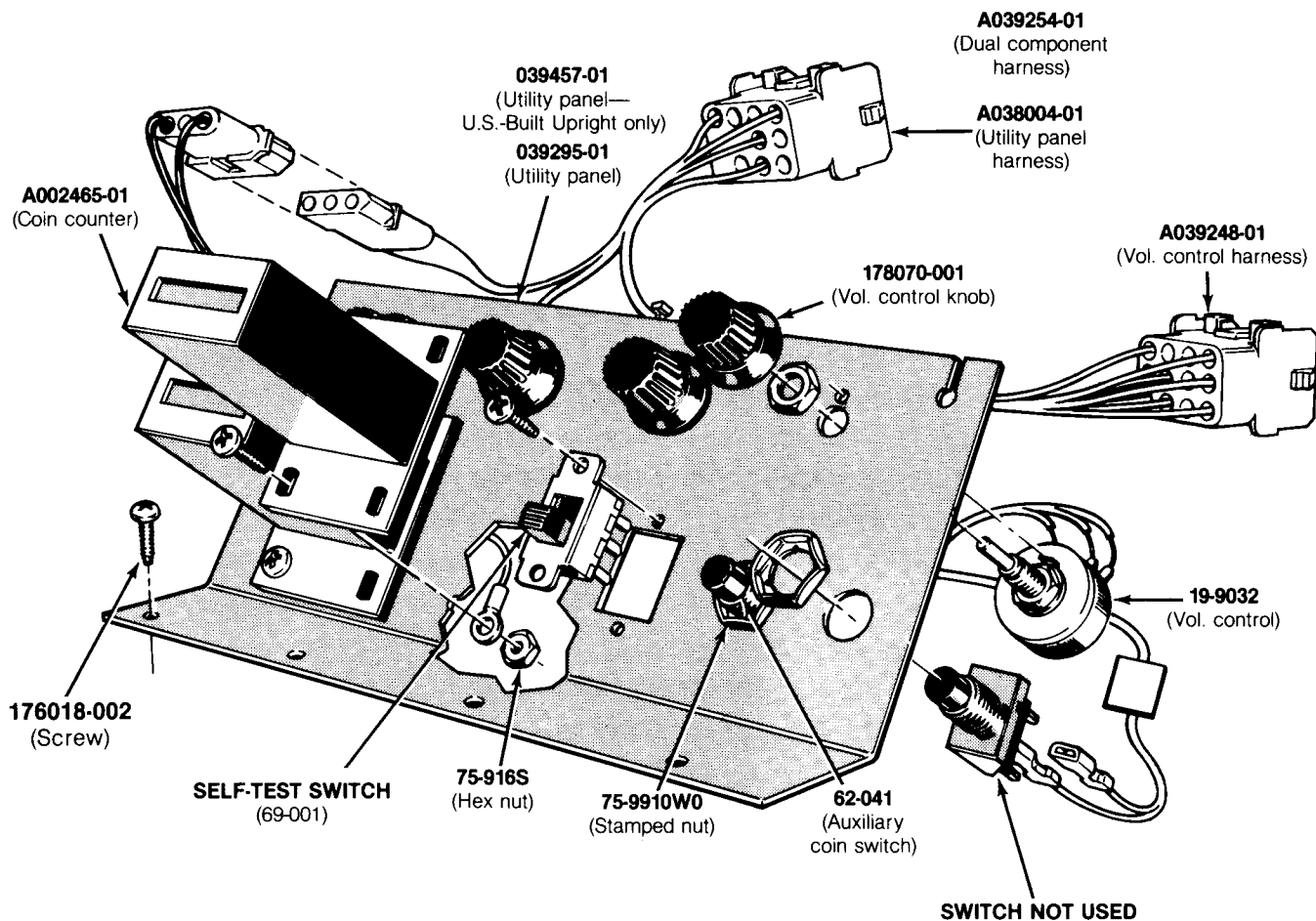
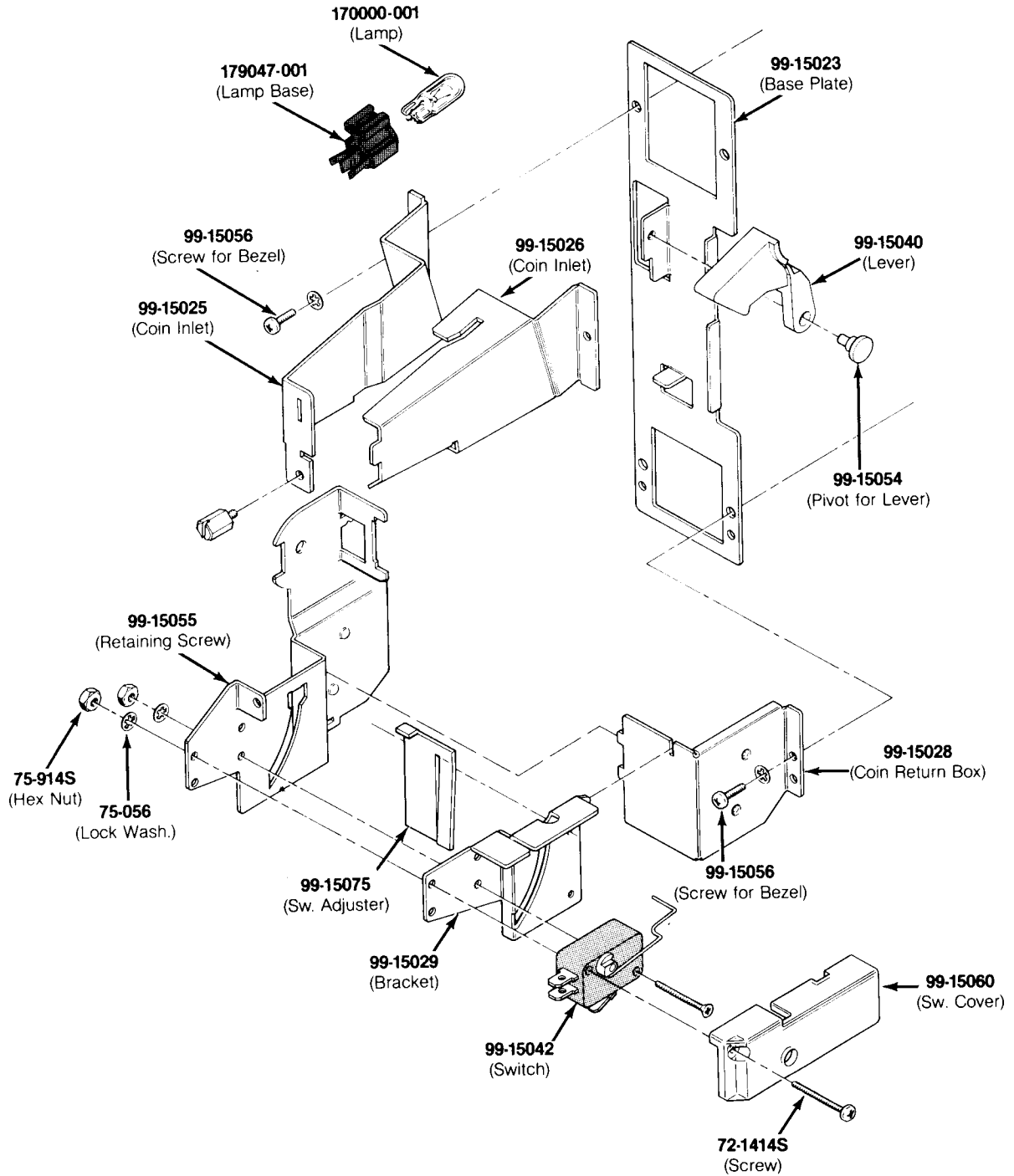

**Figure 3-15 Utility Panel Assembly
A039391-xx F**

Utility Panel Assembly Parts List

<i>Part No.</i>	<i>Description</i>
<i>For U.S.-Built Upright Cabinet</i>	
039457-01	Utility Panel <i>(for 2 volume controls)</i>
<i>For Ireland-Built Upright Cabinet</i>	
039295-01	Utility Panel <i>(for 4 volume controls)</i>
<i>For U.S.- and Ireland-Built Upright Cabinet</i>	
A039254-01	Dual Component Harness Assembly
<i>For U.S.- and Ireland-Built Sit-Down Cabinet</i>	
A038004-01	Utility Panel Harness Assembly
A039248-01	Volume Control Harness Assembly
039295-01	Utility Panel <i>(for 4 volume controls)</i>
<i>For U.S.- and Ireland-Built Upright and Sit-Down Cabinets</i>	
A002465-01	6 V Coin Counter
19-9032	50 Ω , 12.5 W Volume Control
62-041	SPST Momentary-Contact Pushbutton Auxiliary Coin Switch with Black Cap
69-001	DPDT Self-Test Switch
176018-002	#6-32 x 1/2-Inch Thread-Forming Screw
75-916S	#6-32 Steel Machine Hex Nut
75-9910W0	#15/32-32 Stamped Nut
178070-001	Volume Control Knob

F. Coin Doors



**Figure 3-16 Vertically Mounted Coin Door
171034-xxx**

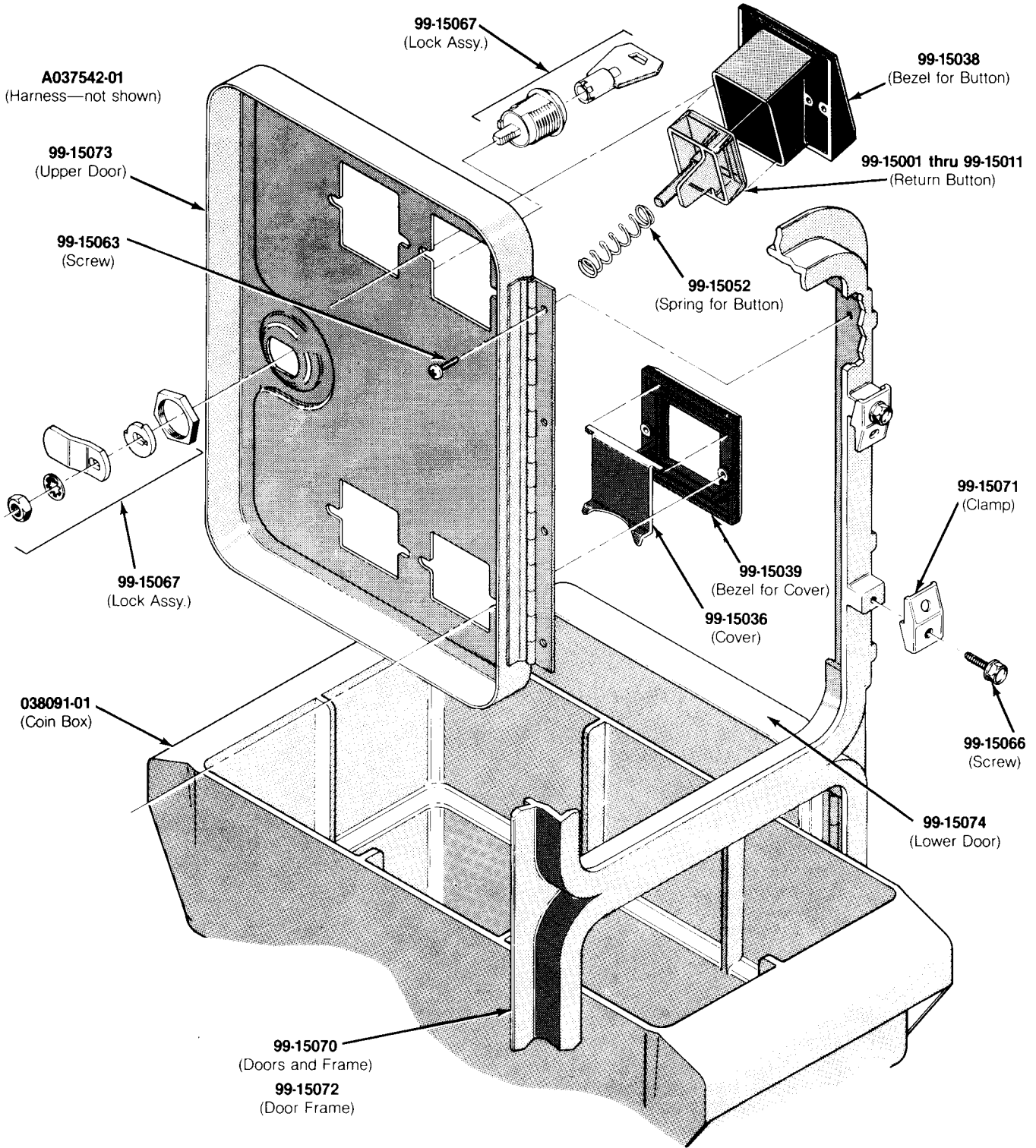

171034-001 — U.S. 25¢/25¢ Coin Door
 171034-003 — Canadian 25¢/25¢ Coin Door
 171034-005 — U.K. 10 P/50 P Coin Door

171034-006 — U.K. 20 P/50 P Coin Door
 171034-009 — German 2 M/1 M Coin Door
 171034-010 — German 2 M/5 M Coin Door

171034-011 — German 1 M/5 M Coin Door
 171034-015 — French 2 F/1 F Coin Door

Figure 3-16 Vertically Mounted Coin Door, continued
171034-xxx

Vertically Mounted Coin Door Parts List

Part No.	Description
A037542-01	Harness Assembly
72-1414S	#4-40 × 7/8-Inch Cross-Recessed Pan-Head Steel Machine Screw
75-056	#6 Internal-Tooth Zinc-Plated Steel Lock Washer
75-914S	#4-40 Steel Machine Hex Nut
75-3414S	#4-40 × 7/8-Inch 82° Cross-Recessed Flat-Head Steel Machine Screw
99-15001	Coin Return Button with U.S. 25¢ Price Plate
99-15002	Coin Return Button with U.S. \$1 Price Plate
99-15003	Coin Return Button with German 1 DM Price Plate
99-15004	Coin Return Button with German 2 DM Price Plate
99-15005	Coin Return Button with German 5 DM Price Plate
99-15006	Coin Return Button with Belgian 5 Fr Price Plate
99-15007	Coin Return Button with French 1 Fr Price Plate
99-15008	Coin Return Button with Japanese 100 Yen Price Plate
99-15009	Coin Return Button with British 10 Pence Price Plate
99-15010	Coin Return Button with Australian 20¢ Price Plate
99-15011	Coin Return Button with Italian 100 Lire Price Plate
99-15023	Base Plate
99-15025	Left Half of Coin Inlet
99-15026	Right Half of Coin Inlet
99-15027	Side Plate of Coin Return Box
99-15028	Base Plate of Coin Return Box
99-15029	Switch Bracket
99-15036	Metal Coin Return Cover
99-15038	Bezel for Coin Return Button
99-15039	Metal Bezel for Coin Return Cover
99-15040	Coin Return Lever
99-15042	Coin Switch for U.S. 25¢
99-15052	Spring for Coin Return Button
99-15054	Pivot for Coin Return Lever
99-15055	Retaining Screw
99-15056	#4-40 × 7/8-Inch Cross-Recessed Pan-Head Steel Machine Screw
99-15060	Switch Cover
99-15063	Screw for Hinge
99-15066	Screw for Clamp
99-15067	Lock Assembly
99-15070	Doors and Frame
99-15071	Clamp for Frame
99-15072	Door Frame
99-15073	Upper Door
99-15074	Lower Door
99-15075	Switch Adjuster
038091-01	Coin Box <i>(Not included in assembly) Acceptable substitute is part number A037491-01</i>
170000-001	6.3 V Miniature Wedge-Base Incandescent Lamp
171006-035	Metal Coin Mechanism
179047-001	Lamp Base

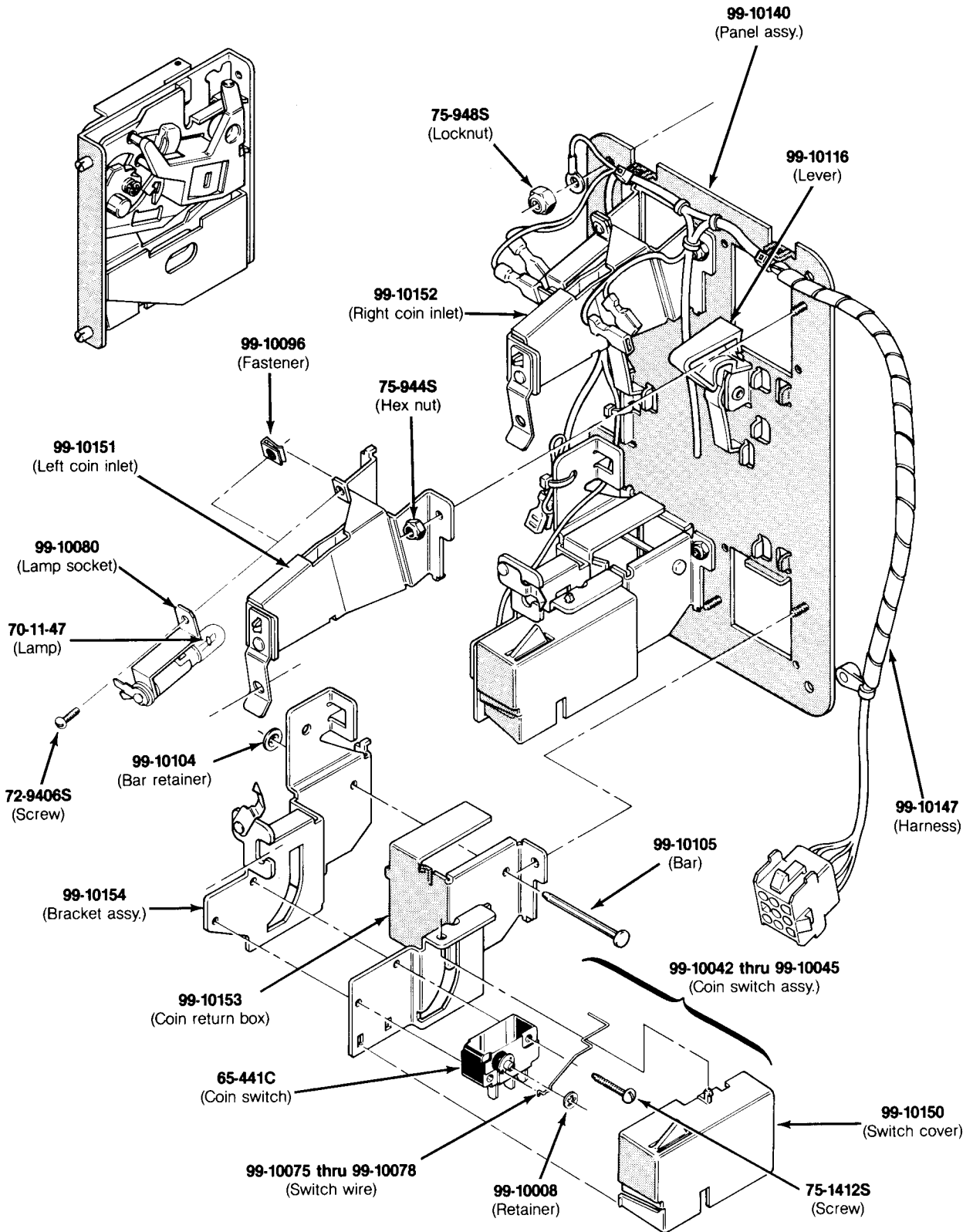

Figure 3-17 American-Made Coin Door 171027-001 A

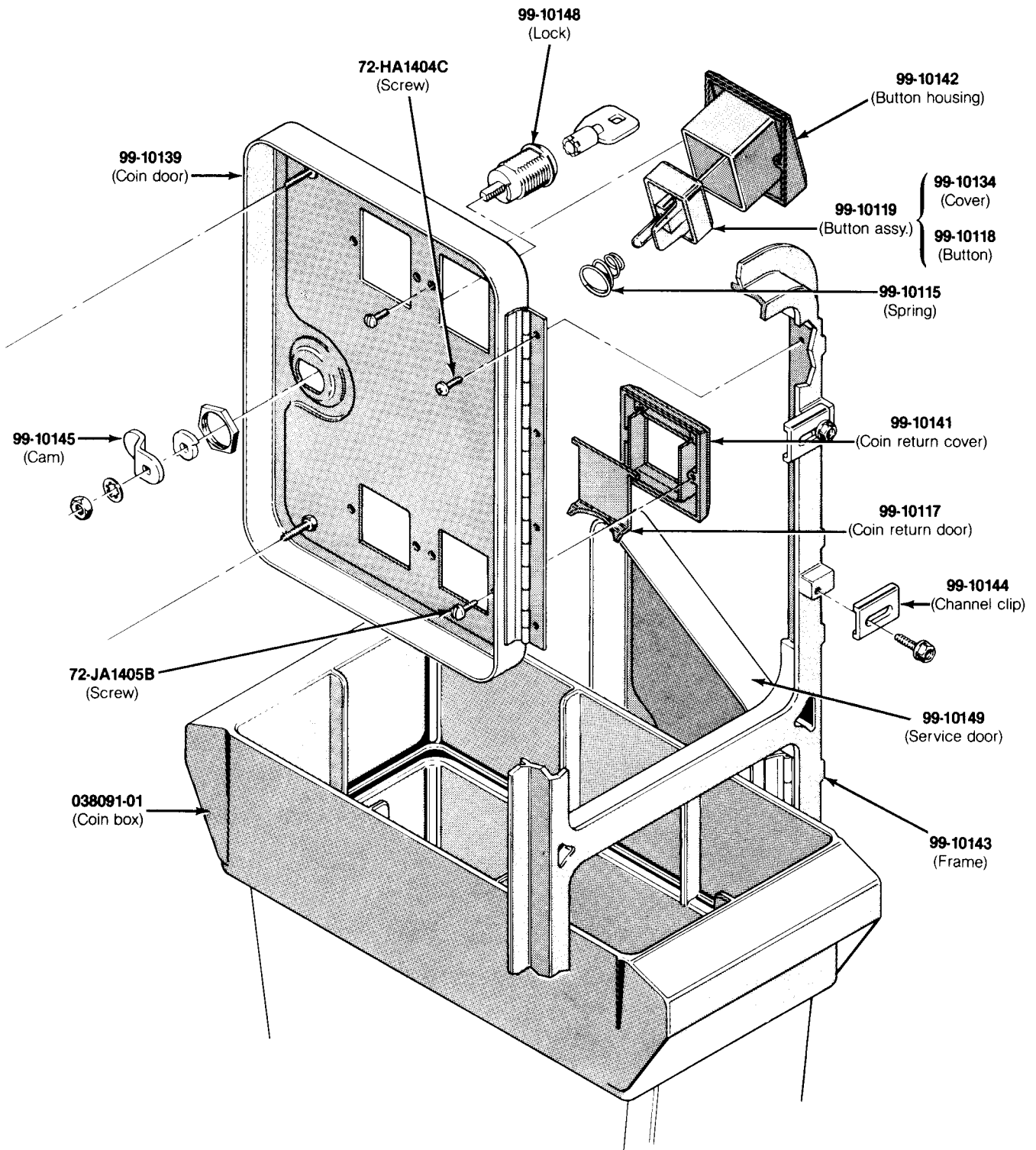

Figure 3-17 American-Made Coin Door, continued
171027-001 A

American-Made Coin Door Parts List

Assemblies and components in the following parts list are shown in Figure 3-17.

<i>Part No.</i>	<i>Description</i>
A039576-01	Coin Option Interconnect Assembly <i>(not shown)</i>
171006-035	Metal Coin Mechanism for U.S. \$.25
65-441C	Coin Switch
70-11-47	Miniature Bayonet Lamp
72-9406S	#4-40 x 3/8-Inch Truss-Head Screw
72-HA1404C	#4-40 x 1/4-Inch Pan-Head Screw
72-JA1405B	#4-40 x .31-Inch Pan-Head Screw
75-1412S	#4-40 x 3/4-Inch Pan-Head Screw
75-994S	#4-40 Lock Nut
99-10008	Retainer
99-10042	Coin Switch Assembly for Belgium 5 Fr and U.S. \$.25
99-10043	Coin Switch Assembly for German 1 DM, Japanese 100 Yen, Swiss 1 Fr
99-10044	Coin Switch Assembly for German 2 DM, Italian 100 L, U.S. \$1.00
99-10045	Coin Switch Assembly for Australian \$.20, German 5 DM, British 10 P
99-10068	Coin Return Chute
99-10075	Switch wire <i>(included in coin switch assembly)</i>
99-10076	Switch wire <i>(included in coin switch assembly)</i>
99-10077	Switch wire <i>(included in coin switch assembly)</i>
99-10078	Switch wire <i>(included in coin switch assembly)</i>
99-10080	Lamp socket
99-10081	Key holder
99-10096	Fastener
99-10104	Bar retainer
99-10105	Bar
99-10115	Spring
99-10116	Plastic Coin Return Lever
99-10117	Steel Coin Return Door
99-10118	Amber Coin Return Button
99-10119	Amber Coin Button for U.S. \$.25
99-10134	Coin Button Cover
99-10139	Coin Door
99-10140	Coin Door Inner-Panel Assembly
99-10141	Diecast Coin Return Cover
99-10142	Diecast Button Housing
99-10143	Coin Door Frame
99-10144	Coin Door Channel Clip
99-10145	Offset Cam <i>(includes 99-10148—Lock)</i>
99-10146	Coin Inlet Chute Assembly
99-10147	American-Made Coin Door Harness
99-10149	Service Door
99-10150	Switch Cover
99-10151	Left Coin Inlet
99-10152	Right Coin Inlet
99-10153	Coin Return Box
99-10154	Bracket Assembly

G. Printed-Circuit Boards

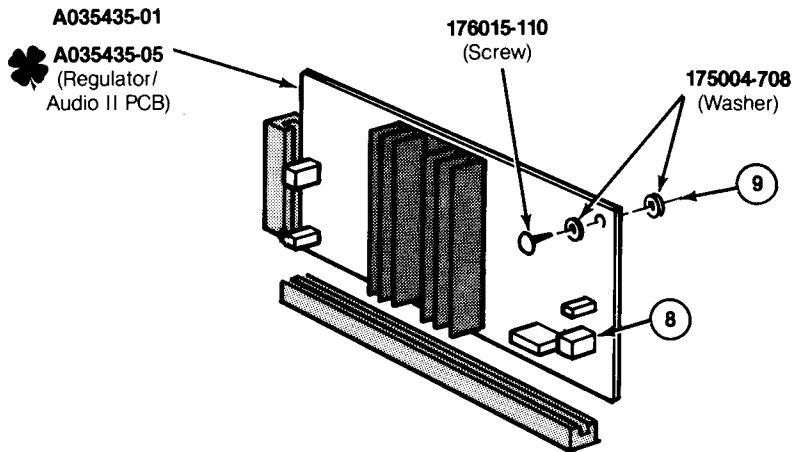
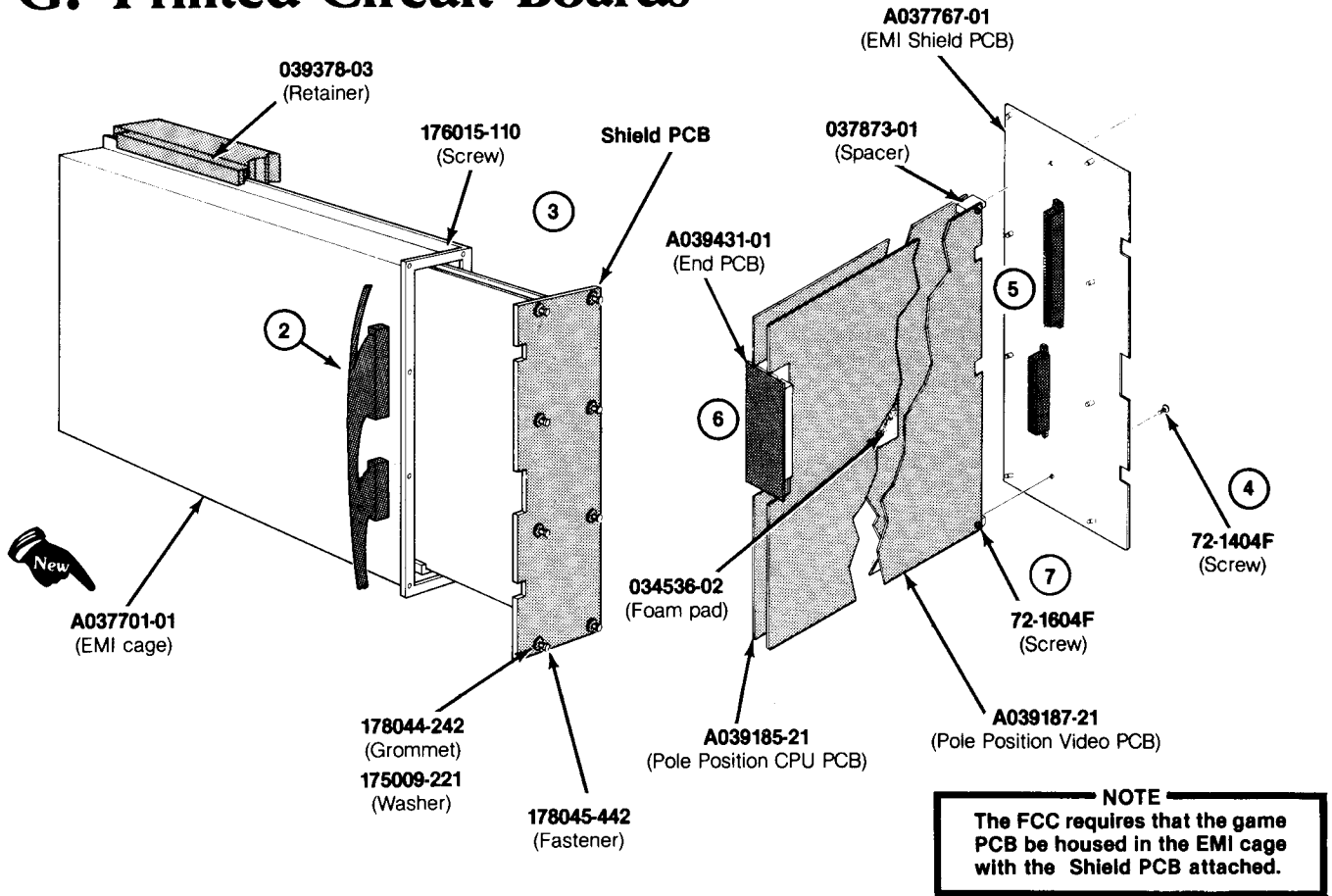

*Steps 1, 10, and 11 are not illustrated.

Figure 3-18 Removing the Printed-Circuit Boards

WARNING

Before you remove or repair any printed-circuit board, **turn the game off.**

Removing the Printed-Circuit Boards:**Removing the Game PCBs from the EMI Cage**

1. Open the rear access panel.
2. The game printed-circuit boards (PCBs) are located inside the electromagnetic interference (EMI) cage (see *Figure 3-18*). The EMI cage is located on the cabinet wall of the *Upright* game and on the inside of the rear access panel of the *Sit-Down* game. Unplug the two harness edge-connectors from the EMI Shield PCB.
3. To remove the game PCBs, pull the eight nylon snap-in fasteners on the EMI Shield PCB to the unlocked position. Carefully slide the Shield PCB and attached PCBs straight out of their guides. Be careful not to twist the boards, as this may loosen connections or components.

Removing the EMI Shield PCB from the Game PCBs

4. Remove the two pan-head screws that connect the EMI Shield PCB to the spacers.
5. Push the EMI Shield PCB off the game PCBs by applying pressure with your thumbs to the edge connectors.

6. Unplug the End PCB that connects the two game PCBs.
7. Determine which PCB you need to repair or replace, and remove the two pan-head screws that connect that PCB to the spacers. Replace or repair as required, and reinstall the PCBs. (Make sure the foam vibration damper is placed between the game PCBs.)

Removing a Regulator/Audio II PCB:

8. To remove a Regulator/Audio II PCB, disconnect the small harness connectors on the board.
9. Remove the hardware that secures the Regulator/Audio II PCB to the cabinet, and carefully lift the board from the retainer. Do not twist the board, as this may loosen connections or components. Replace or repair as required and reinstall the PCB.

CAUTION

Make sure that the connectors on each PCB are properly plugged in. Note that they are keyed to fit only one way. If they do not slip on easily, do not force them. **A reversed connector may damage your game and void the warranty.**

10. Close and lock the rear access panel.
11. **Important:** Perform the self-test.

Printed-Circuit Board Mounting Hardware Parts List

Assemblies and components in the following parts list are shown in *Figure 3-18*.

<i>Part No.</i>	<i>Description</i>
<i>U.S.-Built Upright and Sit-Down Cabinets</i>	
A037701-01	Electromagnetic Interference (EMI) Cage (<i>includes guides</i>)
72-1404F	#4-40 x ¼-Inch Cross-Recessed Steel Screw
72-1604F	#6-32 x ¼-Inch Cross-Recessed Steel Screw
034536-02	Foam Pad
037873-01	Spacer
039378-03	Dual-Slotted Retainer
175004-708	#8 Fiber Washer
175009-221	Plastic Spacer (<i>for EMI shield PCB</i>)
72-6812S	#8 x ¾-Inch Steel Machine Screw
178044-242	Grommet
178045-442	Snap-In Fastener
<i>Ireland-Built Upright and Sit-Down Cabinets*</i>	
72-6624S	#6 x 1 ½-Inch Cross-Recessed Pan-Head Tapping Screw
74-5608NN	#6-32 x ½-Inch Spacer
75-99516	#6-32 Nut/Washer Assembly
034536-02	Foam Pad
039157-02	Dual-Slotted PCB Retainer
175004-706	#6 Fiber Washer
175004-708	#8 Fiber Washer
72-6812S	#8 x ¾-Inch Steel Machine Screw
178020-750	Nylon Spacer

*Not shown in illustration

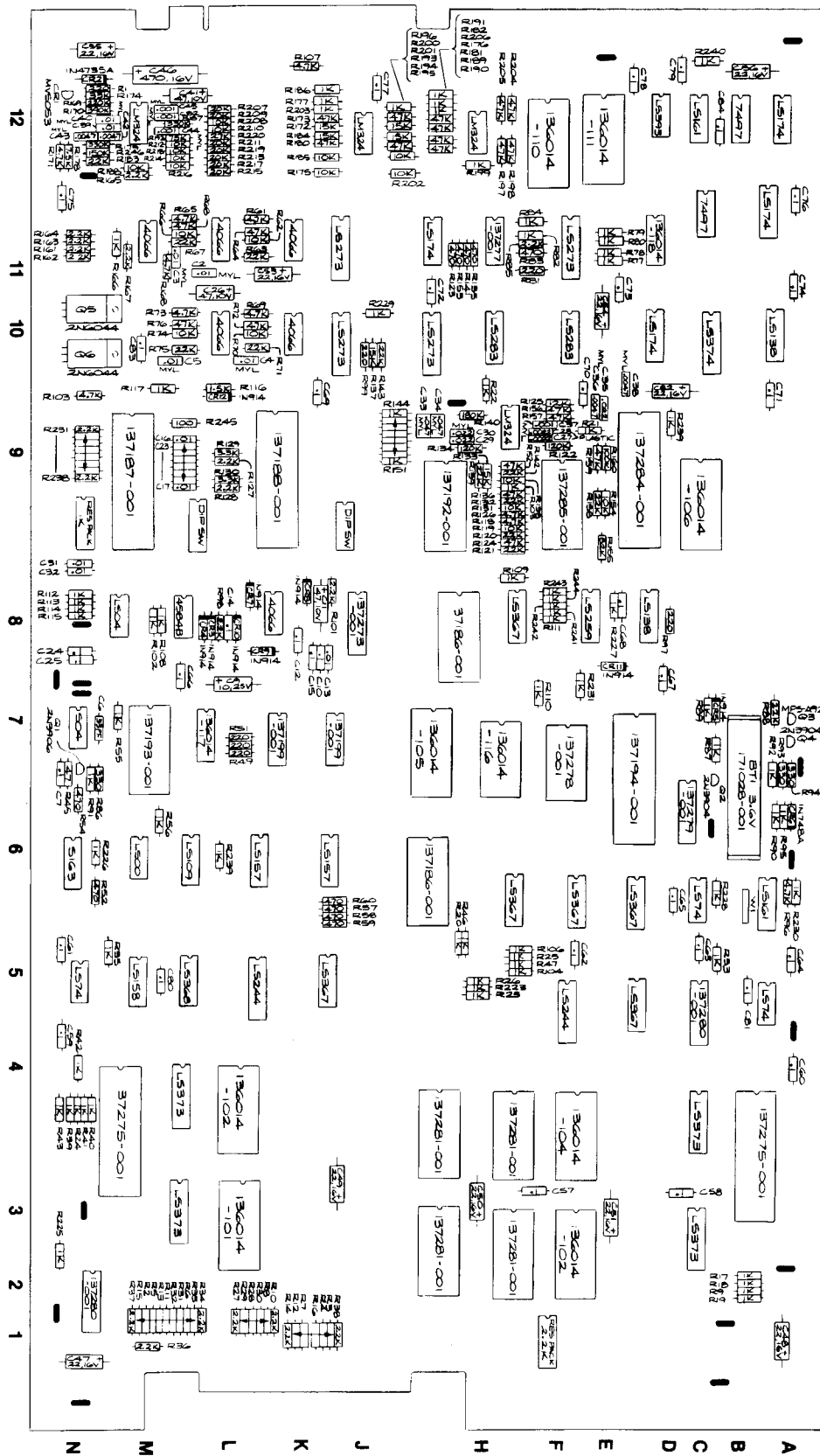

NOTICE TO ALL PERSONS RECEIVING THIS DRAWING
CONFIDENTIAL: Reproduction forbidden without the specific
written permission of Atari, Inc., Sunnyvale, CA. This drawing is
only conditionally issued, and neither receipt nor possession
of the drawing or transfers any right in, or license to use, the
subject matter of the drawing or any design or technical infor-
mation shown thereon, nor any right to reproduce this drawing
or any part thereof. Except for manufacture by vendors of
Atari, Inc., and for manufacture under the corporation's written
license, no right to reproduce this drawing is granted or the
subject matter thereof unless by written agreement with or
written permission from the corporation.

Figure 3-19 Central Processing Unit (CPU) Printed-Circuit Board Assembly
A039185-21 B

Figure 3-16 Central Processing Unit Printed-Circuit Board Assembly Parts List

Assemblies and components in the following parts list are shown in Figure 3-19.

Designator	Description	Part No.
Capacitors		
C2-C5	0.01 μ F, 100 V Radial-Lead Mylar Capacitor	21-101103
C6	33 pF, 100 V Radial-Lead Epoxy-Dipped Mica Capacitor	128002-330
C7	0.1 μ F, \pm 10%, 50 V Ceramic-Disc Axial-Lead Capacitor	122002-104
C9	10 μ F, 25 V Aluminum Electrolytic Fixed Axial-Lead Capacitor	24-250106
C10	0.1 μ F, \pm 10%, 50 V Ceramic-Disc Axial-Lead Capacitor	122002-104
C11	47 μ F, 10 V Aluminum Electrolytic Fixed Axial-Lead Capacitor	24-100476
C12	0.1 μ F, \pm 10%, 50 V Ceramic-Disc Axial-Lead Capacitor	122002-104
C13	0.01 μ F, + 80%, -20%, 25 V Ceramic-Disc Axial-Lead Capacitor	122005-103
C14, C15	0.1 μ F, \pm 10%, 50 V Ceramic-Disc Axial-Lead Capacitor	122002-104
C16-C23	0.01 μ F, + 80%, -20%, 25 V Ceramic-Disc Axial-Lead Capacitor	122005-103
C24, C25	0.1 μ F, \pm 10%, 50 V Ceramic-Disc Axial-Lead Capacitor	122002-104
C26	47 μ F, 10 V Aluminum Electrolytic Fixed Axial-Lead Capacitor	24-100476
C27, C28	0.0022 μ F, \pm 10%, 100 V Radial-Lead Plastic Film Capacitor	121022-222
C29, C30	0.022 μ F, 100 V Radial-Lead Mylar Capacitor	21-101223
C31, C32	0.01 μ F, + 80%, -20%, 25 V Ceramic-Disc Axial-Lead Capacitor	122005-103
C33, C34	0.047 μ F, 100 V Radial-Lead Mylar Capacitor	21-101473
C35	0.022 μ F, 100 V Radial-Lead Mylar Capacitor	21-101223
C36	0.0047 μ F, 100 V Radial-Lead Mylar Capacitor	21-101472
C37	0.001 μ F, 100 V Radial-Lead Mylar Capacitor	21-101102
C38	0.0047 μ F, 100 V Radial-Lead Mylar Capacitor	21-101472
C39, C40	0.01 μ F, 100 V Radial-Lead Mylar Capacitor	21-101103
C41	47 μ F, 10 V Aluminum Electrolytic Fixed Axial-Lead Capacitor	24-100476
C42, C43	0.0047 μ F, 100 V Radial-Lead Mylar Capacitor	21-101472
C44, C45	0.001 μ F, 100 V Radial-Lead Mylar Capacitor	21-101102
C46	470 μ F, 16 V Aluminum Electrolytic Fixed Axial-Lead Capacitor	24-250477
C47-C56	22 μ F, 16 V Aluminum Electrolytic Fixed Axial-Lead Capacitor <i>Acceptable substitute is part no. 24-100477</i>	24-160226
C57-C84	0.1 μ F, \pm 10%, 50 V Ceramic-Disc Axial-Lead Capacitor	122002-104
C82	0.001 μ F, 100 V Radial-Lead Mylar Capacitor	21-101102
Diodes		
CR1	Type-MV5053 Light-Emitting Diode	38-MV5053
CR2	6.2 V, \pm 5%, 1 W Type-1N4735A Zener Diode	131009-001
CR3-CR5	100 V, Type-1N914 Switching Diode	31-1N914
CR6	3.9 V \pm 5% Type-1N748A Zener Diode	131000-002
CR7-CR12	100 V, Type-1N914 Switching Diode	31-1N914
Integrated Circuits		
2N	Type-12L6 Programmable-Array Logic 1	137280-001
3A	Type-Z8002 16-Bit Microprocessor	137275-001
3C	Type-74LS373 Integrated Circuit	37-74LS373
3F, 3H	Custom Integrated Circuit 10	137281-001

(Continued on next page)

Central Processing Unit Printed-Circuit Board Assembly Parts List, continued

Designator	Description	Part No.
3M, 4C	Type-74LS373 Integrated Circuit	37-74LS373
4F, 4H	Custom Integrated Circuit 10	137281-001
4M	Type-74LS373 Integrated Circuit	37-74LS373
4N	Type-Z8002 16-Bit Microprocessor	137275-001
5A	Type-74LS74 Integrated Circuit	37-74LS74
5C	Type-12L6 Programmable-Array Logic 1	137280-001
5D	Type-74LS367 Integrated Circuit	37-74LS367
5E	Type-74LS244 Integrated Circuit	37-74LS244
5J	Type-74LS367 Integrated Circuit	37-74LS367
5K	Type-74LS244 Integrated Circuit	37-74LS244
5L	Type-74LS368 Integrated Circuit	137168-001
5M	Type-74LS158 Integrated Circuit	137203-001
5N	Type-74LS74 Integrated Circuit	37-74LS74
6A	Type-74LS161 Integrated Circuit	37-74LS161
6C	Type-74LS74 Integrated Circuit	37-74LS74
6D-6F	Type-74LS367 Integrated Circuit	37-74LS367
6H	Custom Integrated Circuit 08	137186-001
6J, 6K	Type-74LS157 Integrated Circuit	37-74LS157
6L	Type-74LS109 Integrated Circuit	37-74LS109
6M	Type-74LS00 Integrated Circuit	37-74LS00
6N	Type-74S163 Integrated Circuit	137274-001
7C	Type-10L8 Programmable-Array Logic 3	137279-001
7D	Type-Z80A 8-Bit Microprocessor	137194-001
7M	Custom Integrated Circuit 07	137193-001
7N	Type-74S04 Integrated Circuit	37-74S04
8D	Type-74LS138 Integrated Circuit	137177-001
8E	Type-74LS259 Integrated Circuit	37-74LS259
8F	Type-74LS367 Integrated Circuit	37-74LS367
8H	Custom Integrated Circuit 08	137186-001
8J	Type-ADC0804 Integrated Circuit	137273-001
8K	Type-4066 Integrated Circuit	37-4066
8L	Type-4584B Integrated Circuit	37-4584B
8M	Type-74LS04 Integrated Circuit	37-74LS04
9E	Custom Integrated Circuit 52	137284-001
9FA	Custom Integrated Circuit 54	137285-001
9FB	Type-LM324 Integrated Circuit	37-LM324
9H	Custom Integrated Circuit 06	137192-001
9K	Custom Integrated Circuit 53	137188-001
9M	Custom Integrated Circuit 51	137187-001
10A	Type-74LS138 Integrated Circuit	137177-001
10C	Type-74LS374 Integrated Circuit	37-74LS374
10D	Type-74LS174 Integrated Circuit	37-74LS174
10E, 10F	Type-74LS283 Integrated Circuit	137204-001
10H, 10J	Type-74LS273 Integrated Circuit	37-74LS273
10K, 10L	Type-4066 Integrated Circuit	37-4066
11A	Type-74LS174 Integrated Circuit	37-74LS174
11C	Type-7497 Integrated Circuit	37-7497
11E	Type-74LS273 Integrated Circuit	37-74LS273

(Continued on next page)

Central Processing Unit Printed-Circuit Board Assembly Parts List, continued

<i>Designator</i>	<i>Description</i>	<i>Part No.</i>
11F	Type-4051 Integrated Circuit	137277-001
11H	Type-74LS174 Integrated Circuit	37-74LS174
11J	Type-74LS273 Integrated Circuit	37-74LS273
11K-11M	Type-4066 Integrated Circuit	37-4066
12A	Type-74LS174 Integrated Circuit	37-74LS174
12B	Type-7497 Integrated Circuit	37-7497
12C	Type-74LS161 Integrated Circuit	37-74LS161
12D	Type-74LS393 Integrated Circuit	37-74LS393
12H, 12J, 12M	Type-LM324 Integrated Circuit	37-LM324
Random-Access Memories		
7E	CMOS Random-Access Memory	137278-001
7J, 7K	Random-Access Memory	137199-001
Read-Only Memories		
C9	Electrically Programmable Read-Only Memory <i>Acceptable substitute is part no. 136014-147</i>	136014-106
3E	Electrically Programmable Read-Only Memory	136014-203
3L	Electrically Programmable Read-Only Memory	136014-101
4E	Electrically Programmable Read-Only Memory	136014-204
4L	Electrically Programmable Read-Only Memory	136014-102
7F	Electrically Programmable Read-Only Memory	136014-116
7H	Electrically Programmable Read-Only Memory	136014-105
7L	Programmable Read-Only Memory <i>Acceptable substitute is part no. 136014-160 for Ireland-Built cabinets</i>	136014-117
11D	Programmable Read-Only Memory	136014-118
12E	Electrically Programmable Read-Only Memory <i>Acceptable substitute is part no. 136014-149</i>	136014-111
12F	Electrically Programmable Read-Only Memory <i>Acceptable substitute is part no. 136014-148</i>	136014-110
Resistors		
R1	220 Ω , $\pm 5\%$, 1/4 W Resistor	110000-221
R2-R8	2.2 k Ω , $\pm 5\%$, 1/4 W Resistor	110000-222
R9	1 k Ω , $\pm 5\%$, 1/4 W Resistor	110000-102
R10-R16	2.2 k Ω , $\pm 5\%$, 1/4 W Resistor	110000-222
R17-R20	1 k Ω , $\pm 5\%$, 1/4 W Resistor	110000-102
R21-R26	1 k Ω , $\pm 5\%$, 1/4 W Resistor	110000-102
R27-R34	2.2 k Ω , $\pm 5\%$, 1/4 W Resistor	110000-222
R35	1 k Ω , $\pm 5\%$, 1/4 W Resistor	110000-102
R36-R38	2.2 k Ω , $\pm 5\%$, 1/4 W Resistor	110000-222
R39-R43	1 k Ω , $\pm 5\%$, 1/4 W Resistor	110000-102
R45	47 Ω , $\pm 5\%$, 1/4 W Resistor	110000-470
R46, R47	1 k Ω , $\pm 5\%$, 1/4 W Resistor	110000-102
R49-R51	220 Ω , $\pm 5\%$, 1/4 W Resistor	110000-221
R52	470 Ω , $\pm 5\%$, 1/4 W Resistor	110000-471
R53	1 k Ω , $\pm 5\%$, 1/4 W Resistor	110000-102
R54	470 Ω , $\pm 5\%$, 1/4 W Resistor	110000-471

(Continued on next page)

Central Processing Unit Printed-Circuit Board Assembly Parts List, continued

Designator	Description	Part No.
R55, R56	1 k Ω , \pm 5%, 1/4 W Resistor	110000-102
R57-R60	470 Ω , \pm 5%, 1/4 W Resistor	110000-471
R61	4.7 k Ω , \pm 5%, 1/4 W Resistor	110000-472
R62	10 k Ω , \pm 5%, 1/4 W Resistor	110000-103
R63	22 k Ω , \pm 5%, 1/4 W Resistor	110000-223
R64	47 k Ω , \pm 5%, 1/4 W Resistor	110000-473
R65	4.7 k Ω , \pm 5%, 1/4 W Resistor	110000-472
R66	10 k Ω , \pm 5%, 1/4 W Resistor	110000-103
R67	22 k Ω , \pm 5%, 1/4 W Resistor	110000-223
R68	47 k Ω , \pm 5%, 1/4 W Resistor	110000-473
R69	4.7 k Ω , \pm 5%, 1/4 W Resistor	110000-472
R70	10 k Ω , \pm 5%, 1/4 W Resistor	110000-103
R71	22 k Ω , \pm 5%, 1/4 W Resistor	110000-223
R72	47 k Ω , \pm 5%, 1/4 W Resistor	110000-473
R73	4.7 k Ω , \pm 5%, 1/4 W Resistor	110000-472
R74	10 k Ω , \pm 5%, 1/4 W Resistor	110000-103
R75	22 k Ω , \pm 5%, 1/4 W Resistor	110000-472
R76	47 k Ω , \pm 5%, 1/4 W Resistor	110000-473
R77-R80	1 k Ω , \pm 5%, 1/4 W Resistor	110000-102
R81	220 Ω , \pm 5%, 1/4 W Resistor	110000-221
R82	1 k Ω , \pm 5%, 1/4 W Resistor	110000-102
R83	470 Ω , \pm 5%, 1/4 W Resistor	110000-471
R84	1 k Ω , \pm 5%, 1/4 W Resistor	110000-102
R85	2.2 k Ω , \pm 5%, 1/4 W Resistor	110000-222
R86	330 Ω , \pm 5%, 1/4 W Resistor	110000-331
R87	1 k Ω , \pm 5%, 1/4 W Resistor	110000-102
R88	22 k Ω , \pm 5%, 1/4 W Resistor	110000-223
R89-R92	1 k Ω , \pm 5%, 1/4 W Resistor	110000-102
R93, R94	330 Ω , \pm 5%, 1/4 W Resistor	110000-331
R95	1 k Ω , \pm 5%, 1/4 W Resistor	110000-102
R96	4.7 k Ω , \pm 5%, 1/4 W Resistor	110000-472
R97	220 Ω , \pm 5%, 1/4 W Resistor	110000-221
R98	2.2 k Ω , \pm 5%, 1/4 W Resistor	110000-222
R99	220 Ω , \pm 5%, 1/4 W Resistor	110000-221
R101	2.2 k Ω , \pm 5%, 1/4 W Resistor	110000-222
R102, R104	1 k Ω , \pm 5%, 1/4 W Resistor	110000-102
R103, R107	4.7 k Ω , \pm 5%, 1/4 W Resistor	110000-472
R106, R108-R115	1 k Ω , \pm 5%, 1/4 W Resistor	110000-102
R116	1.5 k Ω , \pm 5%, 1/4 W Resistor	110000-152
R117	1 k Ω , \pm 5%, 1/4 W Resistor	110000-102
R118	4.7 k Ω , \pm 5%, 1/4 W Resistor	110000-472
R119	10 k Ω , \pm 5%, 1/4 W Resistor	110000-103
R120, R121	22 k Ω , \pm 5%, 1/4 W Resistor	110000-223
R122	120 k Ω , \pm 5%, 1/4 W Resistor	110000-124
R123	470 Ω , \pm 5%, 1/4 W Resistor	110000-471
R124	47 k Ω , \pm 5%, 1/4 W Resistor	110000-473
R125	12 k Ω , \pm 5%, 1/4 W Resistor	110000-123
R126	4.7 k Ω , \pm 5%, 1/4 W Resistor	110000-472

(Continued on next page)

Central Processing Unit Printed-Circuit Board Assembly Parts List, continued

<i>Designator</i>	<i>Description</i>	<i>Part No.</i>
R127, R128	2.2 k Ω , \pm 5%, 1/4 W Resistor	110000-222
R129, R130	3.3 k Ω , \pm 5%, 1/4 W Resistor	110000-332
R131	10 k Ω , \pm 5%, 1/4 W Resistor	110000-103
R132	22 k Ω , \pm 5%, 1/4 W Resistor	110000-223
R133	15 k Ω , \pm 5%, 1/4 W Resistor	110000-153
R134	120 k Ω , \pm 5%, 1/4 W Resistor	110000-124
R135	470 Ω , \pm 5%, 1/4 W Resistor	110000-471
R136	47 k Ω , \pm 5%, 1/4 W Resistor	110000-473
R137	15 k Ω , \pm 5%, 1/4 W Resistor	110000-153
R138	10 k Ω , \pm 5%, 1/4 W Resistor	110000-103
R139	22 k Ω , \pm 5%, 1/4 W Resistor	110000-223
R140	180 k Ω , \pm 5%, 1/4 W Resistor	110000-184
R141	470 Ω , \pm 5%, 1/4 W Resistor	110000-471
R142, R143	22 k Ω , \pm 5%, 1/4 W Resistor	110000-223
R144-R151	1 k Ω , \pm 5%, 1/4 W Resistor	110000-102
R152	47 k Ω , \pm 5%, 1/4 W Resistor	110000-473
R153	470 Ω , \pm 5%, 1/4 W Resistor	110000-471
R154	10 k Ω , \pm 5%, 1/4 W Resistor	110000-103
R155	82 k Ω , \pm 5%, 1/4 W Resistor	110000-823
R156, R157	47 k Ω , \pm 5%, 1/4 W Resistor	110000-473
R158	22 k Ω , \pm 5%, 1/4 W Resistor	110000-223
R159	47 k Ω , \pm 5%, 1/4 W Resistor	110000-473
R160	100 k Ω , \pm 5%, 1/4 W Resistor	110000-104
R161-R165	2.2 k Ω , \pm 5%, 1/4 W Resistor	110000-222
R166	1 k Ω , \pm 5%, 1/4 W Resistor	110000-102
R167	2.2 k Ω , \pm 5%, 1/4 W Resistor	110000-222
R168	4.7 k Ω , \pm 5%, 1/4 W Resistor	110000-472
R169	220 k Ω , \pm 5%, 1/4 W Resistor	110000-224
R170	390 k Ω , \pm 5%, 1/4 W Resistor	110000-394
R171	4.7 k Ω , \pm 5%, 1/4 W Resistor	110000-472
R172	15 k Ω , \pm 5%, 1/4 W Resistor	110000-153
R173	47 k Ω , \pm 5%, 1/4 W Resistor	110000-473
R174	33 k Ω , \pm 5%, 1/4 W Resistor	110000-333
R175	10 k Ω , \pm 5%, 1/4 W Resistor	110000-103
R176	47 k Ω , \pm 5%, 1/4 W Resistor	110000-473
R177	1 k Ω , \pm 5%, 1/4 W Resistor	110000-102
R178	7.5 k Ω , \pm 5%, 1/4 W Resistor	110000-752
R179	330 k Ω , \pm 5%, 1/4 W Resistor	110000-334
R180, R181	47 k Ω , \pm 5%, 1/4 W Resistor	110000-473
R182	1 k Ω , \pm 5%, 1/4 W Resistor	110000-102
R183	22 k Ω , \pm 5%, 1/4 W Resistor	110000-223
R184	15 k Ω , \pm 5%, 1/4 W Resistor	110000-153
R185	10 k Ω , \pm 5%, 1/4 W Resistor	110000-103
R186	1 k Ω , \pm 5%, 1/4 W Resistor	110000-102
R187	330 k Ω , \pm 5%, 1/4 W Resistor	110000-334
R188	10 k Ω , \pm 5%, 1/4 W Resistor	110000-103
R189, R190	47 k Ω , \pm 5%, 1/4 W Resistor	110000-473
R191	1 k Ω , \pm 5%, 1/4 W Resistor	110000-102

(Continued on next page)

Central Processing Unit Printed-Circuit Board Assembly Parts List, continued

Designator	Description	Part No.
R192	75 k Ω , \pm 5%, 1/4 W Resistor	110000-753
R193	15 k Ω , \pm 5%, 1/4 W Resistor	110000-153
R194	47 k Ω , \pm 5%, 1/4 W Resistor	110000-473
R195	10 k Ω , \pm 5%, 1/4 W Resistor	110000-103
R196	1 k Ω , \pm 5%, 1/4 W Resistor	110000-102
R197, R198	47 k Ω , \pm 5%, 1/4 W Resistor	110000-473
R199	1 k Ω , \pm 5%, 1/4 W Resistor	110000-102
R200	47 k Ω , \pm 5%, 1/4 W Resistor	110000-473
R201	15 k Ω , \pm 5%, 1/4 W Resistor	110000-153
R202	10 k Ω , \pm 5%, 1/4 W Resistor	110000-103
R203	1 k Ω , \pm 5%, 1/4 W Resistor	110000-102
R204, R205	47 k Ω , \pm 5%, 1/4 W Resistor	110000-473
R206	1 k Ω , \pm 5%, 1/4 W Resistor	110000-102
R207	20 k Ω , \pm 5%, 1/4 W Resistor	110000-203
R208	10 k Ω , \pm 5%, 1/4 W Resistor	110000-103
R209	20 k Ω , \pm 5%, 1/4 W Resistor	110000-203
R210	10 k Ω , \pm 5%, 1/4 W Resistor	110000-103
R211	20 k Ω , \pm 5%, 1/4 W Resistor	110000-203
R212	10 k Ω , \pm 5%, 1/4 W Resistor	110000-103
R213	20 k Ω , \pm 5%, 1/4 W Resistor	110000-203
R214	10 k Ω , \pm 5%, 1/4 W Resistor	110000-103
R215	20 k Ω , \pm 5%, 1/4 W Resistor	110000-203
R216	10 k Ω , \pm 5%, 1/4 W Resistor	110000-103
R217	20 k Ω , \pm 5%, 1/4 W Resistor	110000-203
R218	10 k Ω , \pm 5%, 1/4 W Resistor	110000-103
R219	20 k Ω , \pm 5%, 1/4 W Resistor	110000-203
R220	27 k Ω , \pm 5%, 1/4 W Resistor	110000-273
R223	1 k Ω , \pm 5%, 1/4 W Resistor	110000-102
R225-R231	1 k Ω , \pm 5%, 1/4 W Resistor	110000-102
R231-R238	2.2 k Ω , \pm 5%, 1/4 W Resistor	110000-222
R239-R244	1 k Ω , \pm 5%, 1/4 W Resistor	110000-102
R245	100 Ω , \pm 5%, 1/4 W Resistor	110000-101
R246	150 k Ω , \pm 5%, 1/4 W Resistor	110000-154
1E	2.2 k Ω , \pm 2%, Dual-Inline-Package Resistor Network	118003-222
9N	1 k Ω , \pm 2%, Dual-Inline-Package Resistor Network	118003-102

Sockets

3A	40-Contact Medium-Insertion-Force Integrated Circuit Socket	79-42C40
3E, 3F	28-Contact Medium-Insertion-Force Integrated Circuit Socket	79-42C28
3H	28-Contact Medium-Insertion-Force Integrated Circuit Socket	79-42C28
3L	28-Contact Medium-Insertion-Force Integrated Circuit Socket	79-42C28
4E, 4F	28-Contact Medium-Insertion-Force Integrated Circuit Socket	79-42C28
4H	28-Contact Medium-Insertion-Force Integrated Circuit Socket	79-42C28
4L	28-Contact Medium-Insertion-Force Integrated Circuit Socket	79-42C28
4N	40-Contact Medium-Insertion-Force Integrated Circuit Socket	79-42C40

(Continued on next page)

Central Processing Unit Printed-Circuit Board Assembly Parts List, continued

Designator	Description	Part No.
6H-9H	28-Contact Medium-Insertion-Force Integrated Circuit Socket	79-42C28
7D	40-Contact Medium-Insertion-Force Integrated Circuit Socket	79-42C40
7E, 7F	24-Contact Medium-Insertion-Force Integrated Circuit Socket	79-42C24
7H	28-Contact Medium-Insertion-Force Integrated Circuit Socket	79-42C28
7M	28-Contact Medium-Insertion-Force Integrated Circuit Socket	79-42C28
8A	28-Contact Medium-Insertion-Force Integrated Circuit Socket	79-42C28
8C	28-Contact Medium-Insertion-Force Integrated Circuit Socket	79-42C28
9C	28-Contact Medium-Insertion-Force Integrated Circuit Socket	79-42C28
9E	42-Contact Medium-Insertion-Force Integrated Circuit Socket	79-42C42
9FA	28-Contact Medium-Insertion-Force Integrated Circuit Socket	79-42C28
9K	42-Contact Medium-Insertion-Force Integrated Circuit Socket	79-42C42
9M	42-Contact Medium-Insertion-Force Integrated Circuit Socket	79-42C42
12E, 12F	28-Contact Medium-Insertion-Force Integrated Circuit Socket	79-42C28
Switches		
9JA	8-Station, Single-Throw, Dual-Inline-Package Bit Switch	66-118PIT
9L	8-Station, Single-Throw, Dual-Inline-Package Bit Switch	66-118PIT
Transistors		
Q1	Type-2N3906 40 V, 1 W, PNP Transistor	33-2N3906
Q2	Type-2N3904 60 V, 350 mW, NPN Transistor	34-2N3904
Q3	Type-MPS-A92 300 V, 500 mA, PNP Transistor	33-MPSA92
Q4	Type-2N3904 60 V, 350 mW, NPN Transistor	34-2N3904
Q5, Q6	Type-2N6044 80 V, 8 A, Darlington NPN Transistor	34-2N6044
Miscellaneous		
BT1	3.6 V, 100 mA Nickel-Cadmium Battery	171028-001
W1	Lead-Spring Socket Terminal	179131-001
	Test Point <i>Acceptable substitute is part no. 020670-01</i>	179051-001
	Jumper Staple	150009-001
Q5, Q6	Nylon Snap-In Fastener	81-4302

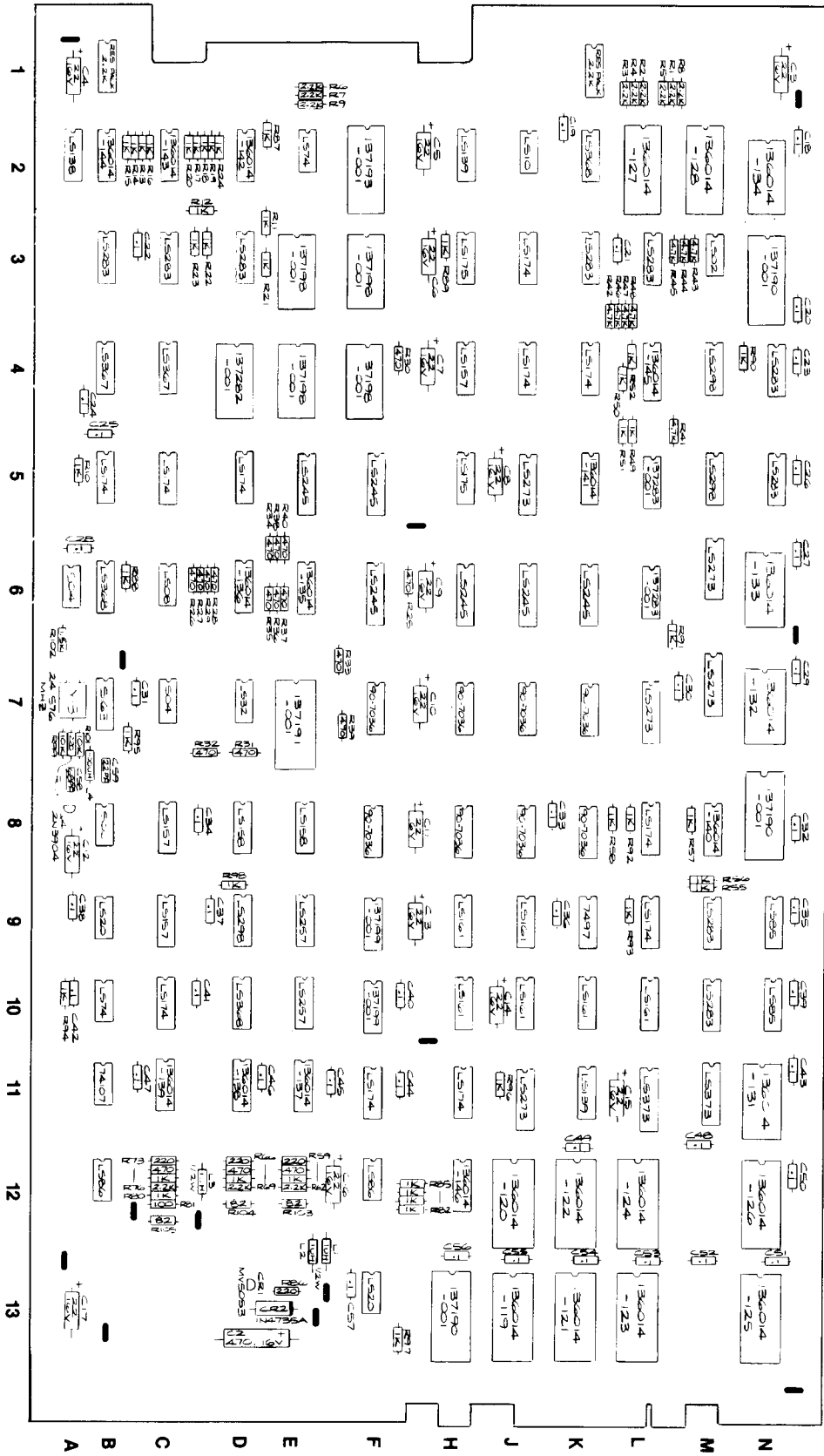

NOTICE TO ALL PERSONS RECEIVING THIS DRAWING
 CONFIDENTIAL. Reproduction forbidden without the specific
 written permission of Atari, Inc., Sunnyvale, CA. This drawing is
 only conditionally issued, and neither receipt nor possession
 thereof confers or transfers any right in, or license to use, the
 subject matter of the drawing or any design or technical infor-
 mation shown thereon, nor any right to reproduce this drawing or
 any part thereof. Except for manufacture by vendors of
 Atari, Inc., and/or manufacture under the corporation's written
 license, no right to reproduce this drawing is granted or the
 subject matter thereof unless by written agreement with or
 written permission from the corporation.

Figure 3-20 Pole Position Video Printed-Circuit Board Assembly
 A039187-21 B

Pole Position Video Printed-Circuit Board Assembly Parts List

Designator	Description	Part No.
Capacitors		
C2	470 μ F, 25 V Aluminum Electrolytic Axial-Lead Capacitor	24-250477
C3-C17	22 μ F, 16 V Aluminum Electrolytic Axial-Lead Capacitor <i>Acceptable substitute is part no. 24-250226</i>	24-160226
C18-C57	0.1 μ F, + 80, -20%, 50 V Ceramic Disk Radial-Lead Capacitor	122002-104
C58	68 pF, 100 V, Mica Capacitor	128002-680
C59	22 pF, 100 V, Mica Capacitor	128002-220
Diodes		
CR1	Type-MV5053 Light-Emitting Diode	38-MV5053
CR2	Type-1N4735A, 6.2 V, 1 W Zener Diode	131009-001
Inductors		
L1-L3	1 μ H, 1/2 W Inductor	141007-001
L4	100 μ H, \pm 10% Inductor	141002-001
Integrated Circuits		
2A	Type-74LS138 Integrated Circuit	137177-001
2E	Type-74LS74 Integrated Circuit	37-74LS74
2H	Type-74LS139 Integrated Circuit	37-74LS139
2J	Type-74LS10 Integrated Circuit	37-74LS10
2K	Type-74LS368 Integrated Circuit	137168-001
3B	Type-74LS283 Integrated Circuit	137204-001
3C	Type-74LS283 Integrated Circuit	137204-001
3D	Type-74LS283 Integrated Circuit	137204-001
3H	Type-74LS175 Integrated Circuit	37-74LS175
3J, 4J	Type-74LS174 Integrated Circuit	37-74LS174
3K	Type-74LS283 Integrated Circuit	137204-001
3L	Type-74LS283 Integrated Circuit	137204-001
3M	Type-74LS02 Integrated Circuit	37-74LS02
4B	Type-74LS367 Integrated Circuit	37-74LS367
4C	Type-74LS367 Integrated Circuit	37-74LS367
4H	Type-74LS157 Integrated Circuit	37-74LS157
4K	Type-74LS174 Integrated Circuit	37-74LS174
4M, 5M	Type-74LS298 Integrated Circuit	137201-001
4N, 5N	Type-74LS283 Integrated Circuit	137204-001
5B	Type-74LS174 Integrated Circuit	37-74LS174
5C	Type-74LS174 Integrated Circuit	37-74LS174
5D	Type-74LS174 Integrated Circuit	37-74LS174
5E	Type-74LS245 Integrated Circuit	37-74LS245
5F, 6F	Type-74LS245 Integrated Circuit	37-74LS245
5H	Type-74LS175 Integrated Circuit	37-74LS175
5J	Type-74LS273 Integrated Circuit	37-74LS273
6A	Type-74S04 Integrated Circuit	37-74S04
6B	Type-74LS368 Integrated Circuit	137168-001
6C	Type-74LS08 Integrated Circuit	37-74LS08
6H	Type-74LS245 Integrated Circuit	37-74LS245
6J	Type-74LS245 Integrated Circuit	37-74LS245
6K	Type-74LS245 Integrated Circuit	37-74LS245
6M, 7M	Type-74LS273 Integrated Circuit	37-74LS273
7B	Type-74S163 Integrated Circuit <i>Acceptable substitute is part no. 137287-001 or -002</i>	137274-001
7C	Type-74S04 Integrated Circuit	37-74S04
7D	Type-74LS32 Integrated Circuit	37-74LS32

(Continued on next page)

Pole Position Video Printed-Circuit Board Assembly Parts List, continued

Designator	Description	Part No.
7L	Type-74LS273 Integrated Circuit	37-74LS273
8B	Type-74S00 Integrated Circuit	37-74S00
8C,9C	Type-74LS157 Integrated Circuit	37-74LS157
8D	Type-74S158 Integrated Circuit	137312-000
8E	Type-74LS158 Integrated Circuit	137203-001
8L,9L	Type-74LS174 Integrated Circuit	37-74LS174
9B	Type-74LS20 Integrated Circuit	37-74LS20
9D	Type-74LS298 Integrated Circuit	137201-001
9E, 10E	Type-74LS257 Integrated Circuit	37-74LS257
9H	Type-74S161 Integrated Circuit	137287-001
9J	Type-74S161 Integrated Circuit	137287-001
9K	Type-7497 Integrated Circuit	37-7497
9M, 10M	Type-74LS283 Integrated Circuit	137204-001
9N	Type-74LS85 Integrated Circuit	37-74LS85
10B	Type-74LS74 Integrated Circuit	37-74LS74
10C	Type-74LS174 Integrated Circuit	37-74LS174
10D	Type-74LS368 Integrated Circuit	137168-001
10H	Type-74S161 Integrated Circuit	137287-001
10J	Type-74S161 Integrated Circuit	137287-001
10K	Type-74S161 Integrated Circuit	137287-001
10L	Type-74S161 Integrated Circuit	137287-001
10N	Type-74LS85 Integrated Circuit	37-74LS85
11B	Type-74107 Integrated Circuit <i>Acceptable substitute is part no. 137169-001</i>	37-74107
11F	Type-74LS174 Integrated Circuit	37-74LS174
11H	Type-74LS174 Integrated Circuit	37-74LS174
11J	Type-74LS273 Integrated Circuit	37-74LS273
11K	Type-74LS139 Integrated Circuit	37-74LS139
11L	Type-74LS373 Integrated Circuit	37-74LS373
11M	Type-74LS373 Integrated Circuit	37-74LS373
12B	Type-74LS08 Integrated Circuit	37-74LS08
12F	Type-74LS86 Integrated Circuit	37-74LS86
13F	Type-74LS20 Integrated Circuit	37-74LS20
<i>For -21 version only</i>		
2F	Type-07 Custom Integrated Circuit	137193-001
3N	Type-02 Custom Integrated Circuit	137190-001
4D	Type-09 Custom Integrated Circuit	137282-001
5L, 6L	Type-03 Custom Integrated Circuit	137283-001
7E	Type-04 Custom Integrated Circuit	137191-001
8N	Type-02 Custom Integrated Circuit	137190-001
13H	Type-02 Custom Integrated Circuit	137190-001
Random-Access Memories		
3E, 4E	Random-Access Memory (200 ns) <i>Acceptable substitute is part no. 137211-001 (150 ns)</i>	137198-001
3F, 4F	Random-Access Memory (200 ns) <i>Acceptable substitute is part no. 137211-001 (150 ns)</i>	137198-001
7F, 8F	Type-2114-2 (200 ns) Random-Access Memory	90-7036
7H, 8H	Type-2114-2 (200 ns) Random-Access Memory	90-7036
7J, 8J	Type-2114-2 (200 ns) Random-Access Memory	90-7036
7K, 8K	Type-2114-2 (200 ns) Random-Access Memory	90-7036
9F, 10F	55 ns Random-Access Memory	137199-001

(Continued on next page)

Pole Position Video Printed-Circuit Board Assembly Parts List, continued

Designator	Description	Part No.
Programmable Read-Only Memories		
2B	Type-82S129(17) Programmable Read-Only Memory	136014-144
2C	Type-82S129(16) Programmable Read-Only Memory	136014-143
2D	Type-82S129(15) Programmable Read-Only Memory	136014-142
4L	Type-82S137(12) Programmable Read-Only Memory	136014-145
5K	Type-82S129(11) Programmable Read-Only Memory	136014-141
6D	Type-82S123(14) Programmable Read-Only Memory	136014-136
6E	Type-82S123(13) Programmable Read-Only Memory	136014-135
8M	Type-82S129(10) Programmable Read-Only Memory	136014-140
11C	Type-82S129(9) Programmable Read-Only Memory	136014-139
11D	Type-82S129(8) Programmable Read-Only Memory	136014-138
11E	Type-82S129(7) Programmable Read-Only Memory	136014-137
12H	Type-82S137(6) Programmable Read-Only Memory	136014-146
<i>For -21 version only</i>		
2L	Electrically Programmable Read-Only Memory <i>Acceptable</i> <i>substitute is part no. 136014-158</i>	136014-127
2M	Electrically Programmable Read-Only Memory <i>Acceptable</i> <i>substitute is part no. 136014-159</i>	136014-128
2N	Electrically Programmable Read-Only Memory <i>Acceptable</i> <i>substitute is part no. 137205-001</i>	136014-134
6N	Electrically Programmable Read-Only Memory <i>Acceptable</i> <i>substitute is part no. 137205-001</i>	136014-133
7N	Electrically Programmable Read-Only Memory <i>Acceptable</i> <i>substitute is part no. 137205-001</i>	136014-132
11N	Electrically Programmable Read-Only Memory <i>Acceptable</i> <i>substitute is part no. 136014-131</i>	136014-231
12J	Electrically Programmable Read-Only Memory <i>Acceptable</i> <i>substitute is part no. 136014-151</i>	136014-120
12K	Electrically Programmable Read-Only Memory <i>Acceptable</i> <i>substitute is part no. 136014-153</i>	136014-122
12L	Electrically Programmable Read-Only Memory <i>Acceptable</i> <i>substitute is part no. 136014-155</i>	136014-124
12N	Electrically Programmable Read-Only Memory <i>Acceptable</i> <i>substitute is part no. 136014-157</i>	136014-126
13J	Electrically Programmable Read-Only Memory <i>Acceptable</i> <i>substitute is part no. 136014-150</i>	136014-119
13K	Electrically Programmable Read-Only Memory <i>Acceptable</i> <i>substitute is part no. 136014-152</i>	136014-121
13L	Electrically Programmable Read-Only Memory <i>Acceptable</i> <i>substitute is part no. 136014-154</i>	136014-123
13N	Electrically Programmable Read-Only Memory <i>Acceptable</i> <i>substitute is part no. 136014-156</i>	136014-125
Resistors		
R1-R9	2.2 k Ω , \pm 5%, 1/4 W Resistor	110000-222
R10-R24	1 k Ω , \pm 5%, 1/4 W Resistor	110000-102
R25-R40	470 Ω , \pm 5%, 1/4 W Resistor	110000-471
R41-R48	4.7 k Ω , \pm 5%, 1/4 W Resistor	110000-472
R49-R52	1 k Ω , \pm 5%, 1/4 W Resistor	110000-102
R55-R58	1 k Ω , \pm 5%, 1/4 W Resistor	110000-102
R59	220 Ω , \pm 5%, 1/4 W Resistor	110000-221
R60	470 Ω , \pm 5%, 1/4 W Resistor	110000-471

(Continued on next page)

Pole Position Video Printed-Circuit Board Assembly Parts List, continued

Designator	Description	Part No.
R61	1 k Ω , \pm 5%, 1/4 W Resistor	110000-102
R62	2.2 k Ω , \pm 5%, 1/4 W Resistor	110000-222
R66	220 Ω , \pm 5%, 1/4 W Resistor	110000-221
R67	470 Ω , \pm 5%, 1/4 W Resistor	110000-471
R68	1 k Ω , \pm 5%, 1/4 W Resistor	110000-102
R69	2.2 k Ω , \pm 5%, 1/4 W Resistor	110000-222
R73	220 Ω , \pm 5%, 1/4 W Resistor	110000-221
R74	470 Ω , \pm 5%, 1/4 W Resistor	110000-471
R75	1 k Ω , \pm 5%, 1/4 W Resistor	110000-102
R76	2.2 k Ω , \pm 5%, 1/4 W Resistor	110000-222
R80	1 k Ω , \pm 5%, 1/4 W Resistor	110000-102
R81	100 Ω , \pm 5%, 1/4 W Resistor	110000-101
R82-R85	1 k Ω , \pm 5%, 1/4 W Resistor	110000-102
R86	220 Ω , \pm 5%, 1/4 W Resistor	110000-221
R87-R98	1 k Ω , \pm 5%, 1/4 W Resistor	110000-102
R99	10 k Ω , \pm 5%, 1/4 W Resistor	110000-103
R100	220 Ω , \pm 5%, 1/4 W Resistor	110000-221
R101	10 k Ω , \pm 5%, 1/4 W Resistor	110000-103
R102	470 k Ω , \pm 5%, 1/4 W Resistor	110000-471
R103-R105	82 Ω , \pm 5%, 1/4 W Resistor	110000-820
1B	2.2 k Ω , \pm 2%, 15-Element, Dual-Inline Package Resistor Pack	118003-222
1K	2.2 k Ω , \pm 2%, 15-Element, Dual-Inline Package Resistor Pack	118003-222
Sockets		
2F	28-Contact Medium-Insertion-Force Integrated Circuit Socket	79-42C28
2L	28-Contact Medium-Insertion-Force Integrated Circuit Socket	79-42C28
2M	28-Contact Medium-Insertion-Force Integrated Circuit Socket	79-42C28
2N	24-Contact Medium-Insertion-Force Integrated Circuit Socket	79-42C24
3E, 4E	24-Contact Medium-Insertion-Force Integrated Circuit Socket	79-42C24
3F, 4F	24-Contact Medium-Insertion-Force Integrated Circuit Socket	79-42C24
3N	28-Contact Medium-Insertion-Force Integrated Circuit Socket	79-42C28
4D	24-Contact Medium-Insertion-Force Integrated Circuit Socket	79-42C24
5L, 6L	18-Contact Medium-Insertion-Force Integrated Circuit Socket	79-42C18
6N, 7N	24-Contact Medium-Insertion-Force Integrated Circuit Socket	79-42C24
7E	28-Contact Medium-Insertion-Force Integrated Circuit Socket	79-42C28
8N	28-Contact Medium-Insertion-Force Integrated Circuit Socket	79-42C28
11N	24-Contact Medium-Insertion-Force Integrated Circuit Socket	79-42C24
12J, 13J	28-Contact Medium-Insertion-Force Integrated Circuit Socket	79-42C28
12K, 13K	28-Contact Medium-Insertion-Force Integrated Circuit Socket	79-42C28
12L, 13L	28-Contact Medium-Insertion-Force Integrated Circuit Socket	79-42C28
12N, 13N	28-Contact Medium-Insertion-Force Integrated Circuit Socket	79-42C28
13H	28-Contact Medium-Insertion-Force Integrated Circuit Socket	79-42C28
Transistor		
Q4	Type-2N3904, 60 V, 1 W, NPN Transistor	34-2N3904
Miscellaneous		
Y1B	Test Points Acceptable substitute is part no. 020670-01 24.576 MHz Crystal Acceptable substitute is part no. 144004-002	179051-002 144004-003

NOTICE TO ALL PERSONS RECEIVING THIS DRAWING CONFIDENTIAL. Reproduction forbidden without the specific written permission of Atari, Inc., Sunnyvale, CA. This drawing is only conditionally issued, and neither receipt nor possession thereof confers or transfers any right in, or license to use, the subject matter of the drawing or any design or technical information shown thereon, nor any right to reproduce this drawing or any part thereof. Except for manufacture by vendors of Atari, Inc., and for manufacture under the corporation's written license, no right to reproduce this drawing is granted or the subject matter thereof unless by written agreement with or written permission from the corporation.

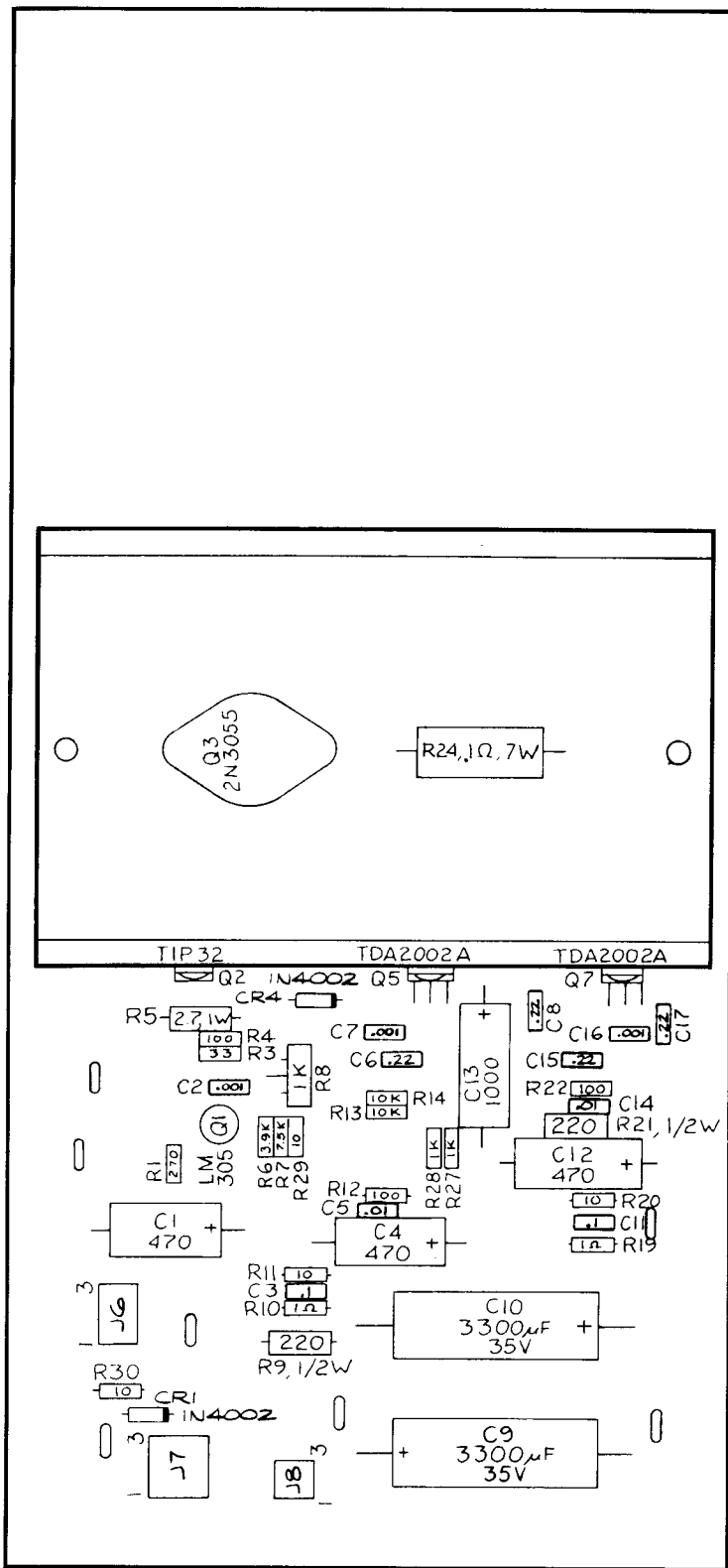

Figure 3-21 Regulator/Audio II PCB Assembly
U.S.-Built Cabinet A035435-01 G

NOTICE TO ALL PERSONS RECEIVING THIS DRAWING
CONFIDENTIAL: Reproduction forbidden without the specific written permission of Atari, Inc., Sunnyvale, CA. This drawing is only conditionally issued, and neither receipt nor possession thereof confers or transfers any right in, or license to use, the subject matter of the drawing or any design or technical information shown thereon, nor any right to reproduce this drawing or any part thereof. Except for manufacture by vendors of Atari, Inc., and for manufacture under the corporation's written license, no right to reproduce this drawing is granted or the subject matter thereof unless by written agreement with or written permission from the corporation.

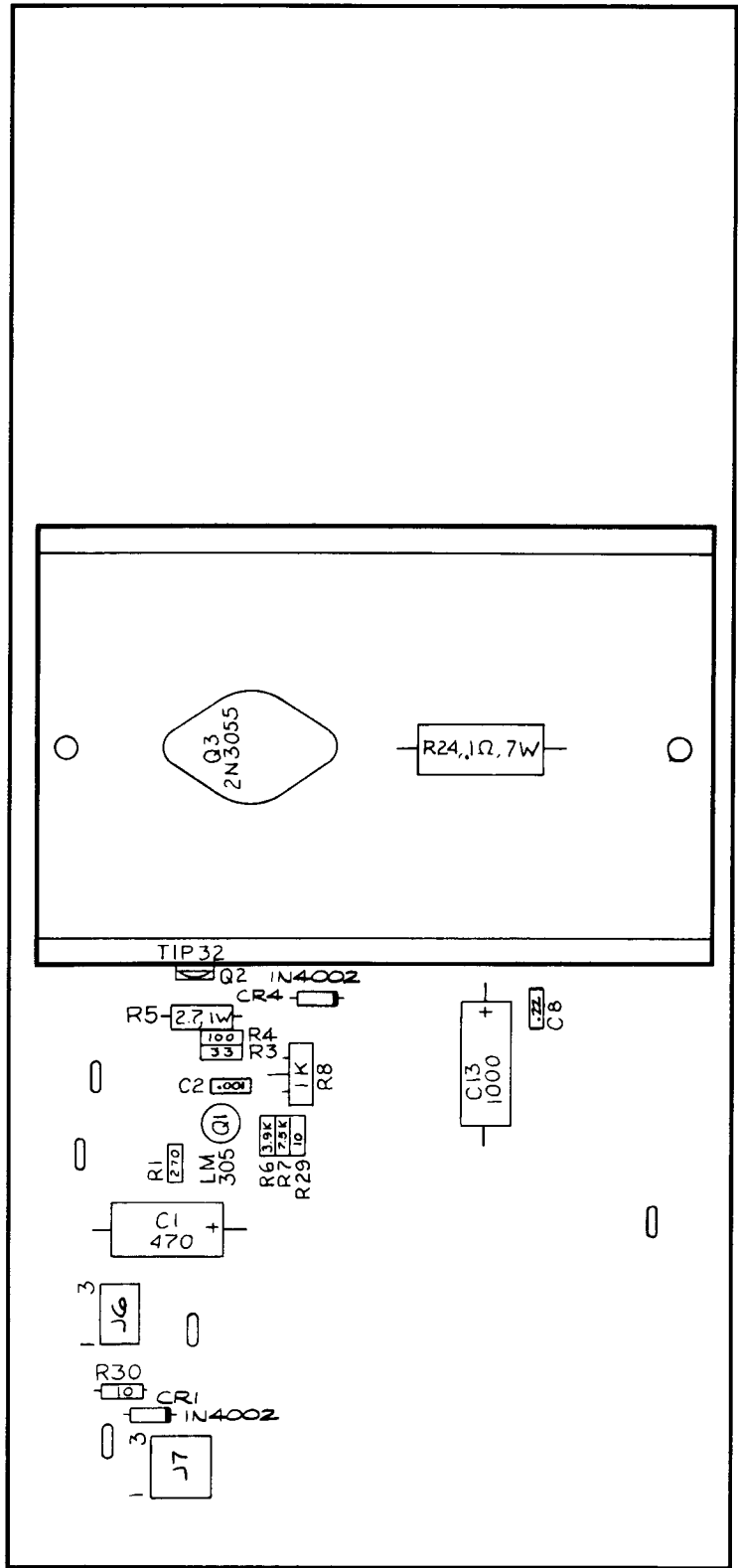

Figure 3-22 Regulator/Audio II PCB Assembly
Ireland-Built Cabinet A035435-05 A

Regulator/Audio II PCB Assembly Parts List

Assemblies and components in the following parts list are shown in Figures 3-21 and 3-22.

Designator	Description	Part No.
Capacitors		
<i>For -01* and -05** versions</i>		
C1	470 μ F, 25 V, Aluminum Electrolytic Fixed Axial-Lead Capacitor	24-250477
C2	0.001 μ F, 25 V, Ceramic-Disc Axial-Lead Capacitor	122002-102
C8	0.22 μ F, 25 V, Ceramic-Disc Axial-Lead Capacitor	122004-224
C13	1000 μ F, 25 V, Aluminum Electrolytic Fixed Axial-Lead Capacitor	24-250108
<i>For -01 version</i>		
C3	0.1 μ F, 25 V, Ceramic-Disc Axial-Lead Capacitor	29-088
C4	470 μ F, 25 V, Aluminum Electrolytic Fixed Axial-Lead Capacitor	24-250477
C5	0.01 μ F, 25 V Minimum, Ceramic-Disc Axial-Lead Capacitor <i>Acceptable substitute is part no. 122005-103</i>	100015-103
C6	0.22 μ F, 25 V, Ceramic-Disc Axial-Lead Capacitor	122004-224
C7	0.001 μ F, 25 V, Ceramic-Disc Axial-Lead Capacitor	122002-102
C9, C10	3300 μ F, 35 V, Aluminum Electrolytic Fixed Axial-Lead Capacitor	24-350338
C11	0.1 μ F, 25 V, Ceramic-Disc Axial-Lead Capacitor	29-088
C12	470 μ F, 25 V, Aluminum Electrolytic Fixed Axial-Lead Capacitor	24-250477
C14	0.01 μ F, 25 V Minimum, Ceramic-Disc Axial-Lead Capacitor <i>Acceptable substitute is part no. 122005-103</i>	100015-103
C15	0.22 μ F, 25 V, Ceramic-Disc Axial-Lead Capacitor	122004-224
C16	0.001 μ F, 25 V, Ceramic-Disc Axial-Lead Capacitor	122002-102
C17	0.22 μ F, 25 V, Ceramic-Disc Axial-Lead Capacitor	122004-224
C18, C19	3300 μ F, 35 V, Aluminum Electrolytic Fixed Axial-Lead Capacitor	24-350338
C20, C21	0.1 μ F, 25 V, Ceramic-Disc Axial-Lead Capacitor	29-088
C22, C23	1 μ F, 50 V, Aluminum Electrolytic Fixed Axial-Lead Capacitor	24-500105
Diodes		
<i>For -01 and -05 versions</i>		
CR1	Type-1N4002, 1 A, 100 V Silicon Rectifier Diode	31-1N4002
CR4	Type-1N4002, 1 A, 100 V Silicon Rectifier Diode	31-1N4002
Integrated Circuits		
<i>For -01 and -05 versions</i>		
Q1	Type-LM305, 5 V, Linear Voltage Regulator	37-LM305
<i>For -01 version</i>		
Q5	Type-TDA2002A, 8 W, Linear Audio Amplifier Integrated Circuit	137151-002
Q7	Type-TDA2002A, 8 W, Linear Audio Amplifier Integrated Circuit	137151-002

(Continued on next page)

*Acceptable substitutes are A035435-02 or -04.

**Acceptable substitutes are A035435-01, -02, or -04.

Regulator/Audio II PCB Assembly Parts List, continued

Designator	Description	Part No.
Resistors		
<i>For -01 and -05 versions</i>		
R1	270 Ω , $\pm 5\%$, 1/4 W Resistor	110000-271
R3	33 Ω , $\pm 5\%$, 1/4 W Resistor	110000-330
R4	100 Ω , $\pm 5\%$, 1/4 W Resistor	110000-101
R5	2.7 Ω , $\pm 5\%$, 1 W Resistor	110009-027
R6	3.9 k Ω , $\pm 5\%$, 1/4 W Resistor	110000-392
R7	7.5 k Ω , $\pm 5\%$, 1/4 W Resistor	110000-752
R8	1 k Ω Vertical PCB-Mounting Cermet Potentiometer <i>Acceptable substitute is part no. 119002-102</i>	19-315102
R24	0.1 Ω , $\pm 3\%$, 7 W Wirewound Resistor	19-100P1015
R29, R30	10 Ω , $\pm 5\%$, 1/4 W Resistor	110000-100
<i>For -01 version</i>		
R9	220 Ω , $\pm 5\%$, 1/2 W Resistor	110001-221
R10	1 Ω , $\pm 5\%$, 1/4 W Resistor	110000-010
R11	10 Ω , $\pm 5\%$, 1/4 W Resistor	110000-100
R12	100 Ω , $\pm 5\%$, 1/4 W Resistor	110000-101
R13, R14	10 k Ω , $\pm 5\%$, 1/4 W Resistor	110000-103
R19	1 Ω , $\pm 5\%$, 1/4 W Resistor	110000-010
R20	10 Ω , $\pm 5\%$, 1/4 W Resistor	110000-100
R21	220 Ω , $\pm 5\%$, 1/2 W Resistor	110001-221
R22	100 Ω , $\pm 5\%$, 1/4 W Resistor	110000-101
R27, R28	1 k Ω , $\pm 5\%$, 1/4 W Resistor	110000-102
Transistors		
<i>For -01 and -05 versions</i>		
Q2	Type-TIP32 PNP Power Transistor	33-TIP32
Q3	Type-2N3055 NPN Silicon Transistor	34-2N3055
Mechanical Parts		
<i>For -01 and -05 versions</i>		
J6	6-Position Connector Receptacle	79-58306
J7	9-Position Connector Receptacle	79-58308
Q3	#6-32 x 1/2-Inch Cross-Recessed Pan-Head Corrosion-Resistant Steel Machine Screw	72-1608C
Q2, Q3	#6-32 Nut/Washer Assembly	75-99516
Q2	Thermally Conductive Silicon Insulator	78-16014
Q3	Thermally Conductive Silicon Insulator	78-16008
Q5	#6-32 x 1/4-Inch Binder-Head Nylon Screw	75-F60405
	Heat Sink	034531-01
	Test Point <i>Acceptable substitute is part no. 020670-01</i>	179051-001
<i>For -01 version</i>		
J8	4-Position Connector Receptacle	79-58354
Q8	#6 x 3/8-Inch Cross-Recessed Pan-Head Thread-Forming Type-AB Zinc-Plated-Steel Screw	72-6606S

NOTICE TO ALL PERSONS RECEIVING THIS DRAWING CONFIDENTIAL: Reproduction forbidden without the specific written permission of Atari, Inc., Sunnyvale, CA. This drawing is only conditionally issued, and neither receipt nor possession thereof confers or transfers any right in, or license to use, the subject matter of the drawing or any design or technical information shown thereon, nor any right to reproduce this drawing or any part thereof. Except for manufacture by vendors of Atari, Inc., and for manufacture under the corporation's written license, no right to reproduce this drawing is granted or the subject matter thereof unless by written agreement with or written permission from the corporation.

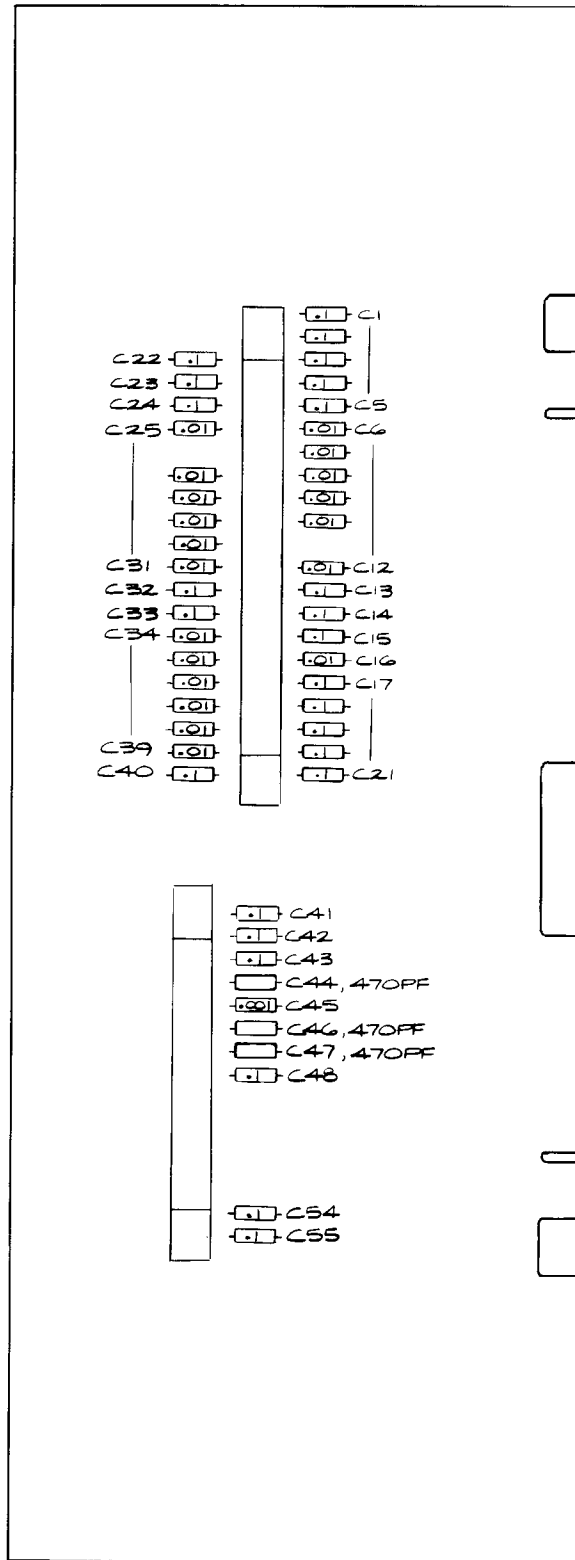

**Figure 3-23 EMI Shield PCB Assembly
A037667-01 A**

EMI Shield PCB Assembly Parts List

Assemblies and components in the following parts list are shown in Figure 3-23.

<i>Designator</i>	<i>Description</i>	<i>Part No.</i>
Capacitors		
C1-C5	0.1 μ F, + 80, -20%, 50 V Ceramic-Disk Radial-Lead Capacitor	122002-104
C6-C10	0.01 μ F, + 80, -20%, 25 V Ceramic-Disk Radial-Lead Capacitor	122005-103
C12	0.01 μ F, + 80, -20%, 25 V Ceramic-Disk Radial-Lead Capacitor	122005-103
C13-C15	0.1 μ F, + 80, -20%, 50 V Ceramic-Disk Radial-Lead Capacitor	122002-104
C16	0.01 μ F, + 80, -20%, 25 V Ceramic-Disk Radial-Lead Capacitor	122005-103
C17-C24	0.1 μ F, + 80, -20%, 50 V Ceramic-Disk Radial-Lead Capacitor	122002-104
C25	0.01 μ F, + 80, -20%, 25 V Ceramic-Disk Radial-Lead Capacitor	122005-103
C27-C31	0.01 μ F, + 80, -20%, 25 V Ceramic-Disk Radial-Lead Capacitor	122005-103
C32,C33	0.1 μ F, + 80, -20%, 50 V Ceramic-Disk Radial-Lead Capacitor	122002-104
C34-C39	0.01 μ F, + 80, -20%, 25 V Ceramic-Disk Radial-Lead Capacitor	122005-103
C40-C43	0.1 μ F, + 80, -20%, 50 V Ceramic-Disk Radial-Lead Capacitor	122002-104
C44	0.471 μ F, + 80, -20%, 100 V Ceramic-Disk Radial-Lead Capacitor	122016-471
C45	0.001 μ F, + 80, -20%, 100 V Ceramic-Disk Radial-Lead Capacitor	122016-102
C46,C47	0.471 μ F, + 80, -20%, 100 V Ceramic-Disk Radial-Lead Capacitor	122016-471
C48	0.1 μ F, + 80, -20%, 50 V Ceramic-Disk Radial-Lead Capacitor	122002-104
C54,C55	0.1 μ F, + 80, -20%, 50 V Ceramic-Disk Radial-Lead Capacitor	122002-104
Connectors		
P19	30-Pin Card-Edge Connector	<i>Acceptable substitute is part no. 179046-030</i> 179073-030
P20	44-Pin Card-Edge Connector	<i>Acceptable substitute is part no. 179046-044</i> 179073-044

H. Power Supply Assembly

WARNING
 Fuse cover must be in place during game operation.

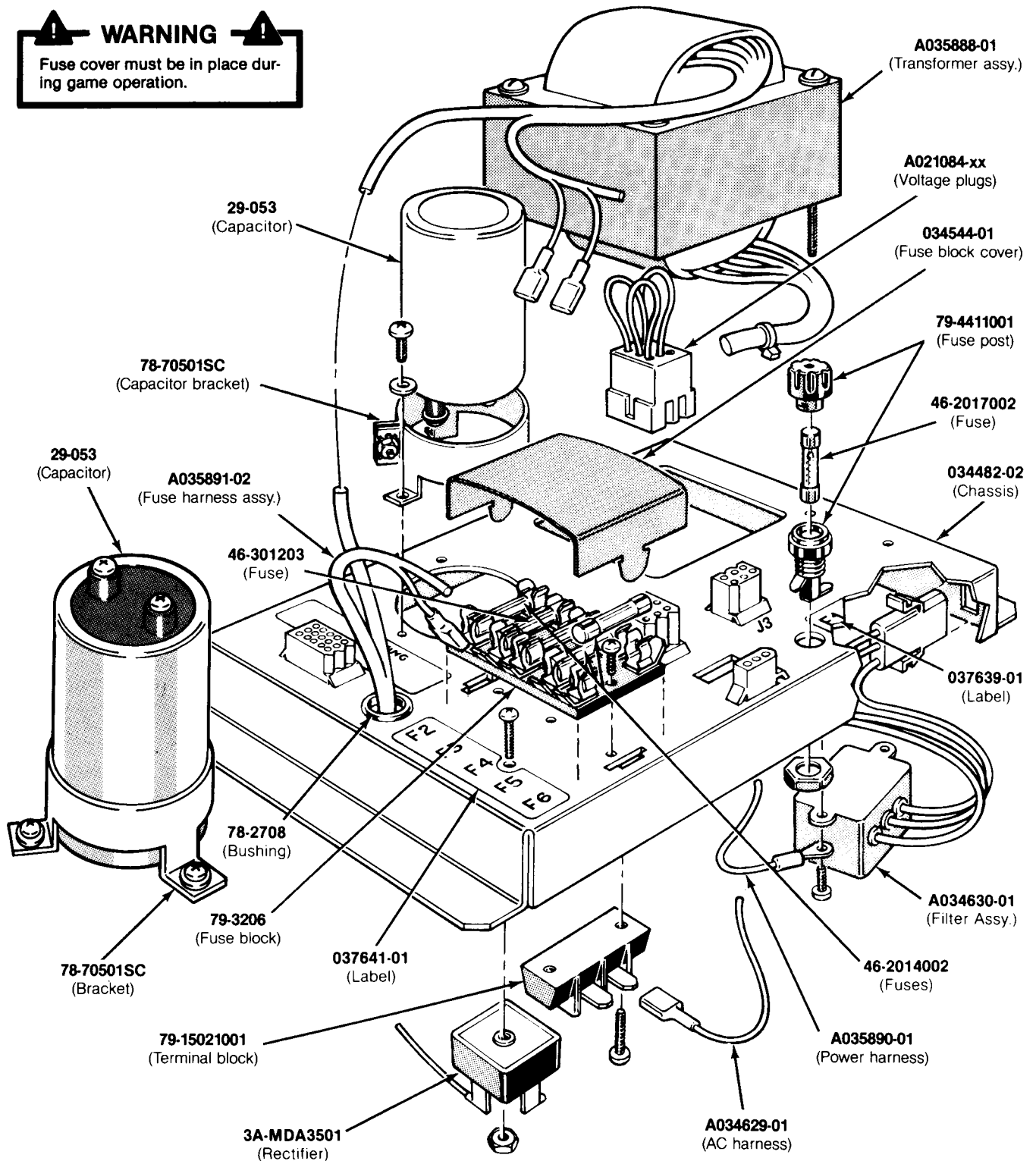

**Figure 3-24 Power Supply Assembly
 A0376721-04 & -05 G**

Power Supply Assembly Parts List

Assemblies and components in the following parts list are shown in Figure 3-24.

Part No.	Description (Reference Designations in Bold)
A021084-01	Voltage Plug for 100V (90–110 VAC) (<i>violet</i>)
A021084-02	Voltage Plug for 120V (105–135 VAC) (<i>yellow</i>)
A021084-04	Voltage Plug for 220V (200–240 VAC) (<i>blue</i>)
A021084-05	Voltage Plug for 240V (220–260 VAC) (<i>brown</i>)
A034629-01	AC Harness Assembly
A034630-01	RFI Filter Assembly (FL1 — <i>designation not marked</i>)
A035888-01	Upright and Cabaret Transformer Assembly (T1) <i>Acceptable substitute is part no. A035888-02</i>
A035890-01	Power Harness Assembly (J2)
A035891-02	Fuse Harness Assembly (F2–F6)
29-053	27,000 μ F 15V DC Electrolytic Capacitor (C1)
3A-MDA3501	Bridge Rectifier, Type MDA 3501 (CR1)
46-2014002	4 A, 250 V, 3AG Slow-Blow Glass Cartridge-Type Fuse (F2, F4–F6)
46-2017002	7 A, 250 V, 3AG Slow-Blow Glass Cartridge-Type Fuse (F1)
46-301253	25 A, 32 V, 3AG Slow-Blow Glass Cartridge-Type Fuse (F3)
78-2708	Nylon Type 6/6 Hole Bushing with $\frac{5}{8}$ -Inch Inside Diameter \times $\frac{5}{8}$ -Inch Outside Diameter \times $\frac{1}{4}$ -Inch Thick
78-70501SC	2-Inch Diameter Capacitor Mounting Bracket (C1)
79-15021001	2-Circuit Single-Row Terminal Block (<i>located under F4</i>)
79-3206	5-Position 3AG Fuse Block with $\frac{1}{4}$ -Inch Quick-Disconnect Terminals (F2–F6)
79-4411001	Panel-Mounting Non-Indicating 3AG Cartridge-Type Fuse Post (F1)
034482-02	Power Supply Chassis
034544-01	Fuse Block Cover (F2–F6)
037639-03, -04	Label for Fuse Value (F1)
037641-01	Label for Fuse Values (F2–F6)

A037671-04 power supply has the 120 V plug.
 A037671-05 has the 100 V, 220 V and 240 V plugs.
 A037671-06 has the 220 V and 240 V plugs.

Glossary of Terms

AC

Alternating current; from zero it rises to a maximum positive level, then passes through zero again to a maximum negative level.

ACTIVE STATE

The true state of a signal. For example: The active state for **START** is low.

ADDRESS

A value that identifies a specific location of data in memory; normally expressed in hexadecimal notation.

ANALOG

Measurable in an absolute quantity (as opposed to on or off). Analog devices are volume controls, light dimmers, stereo amplifiers, etc.

ANODE

The positive (arrow) end of a diode.

AMPLIFIER

A device used to increase the strength of an applied signal.

AMPLITUDE

The maximum instantaneous value of a waveform pulse from zero.

ASTABLE

Having no normal state. An astable device will free-run or oscillate as long as operating voltage is applied. The oscillation frequency is usually controlled by external circuitry.

AUXILIARY COIN SWITCH

A momentary-contact pushbutton switch with a black cap located on the utility panel. The auxiliary coin switch adds credits to the game without activating the coin counter.

BEZEL

A cut, formed, or machined retention device, such as the conical device used to mount a pushbutton switch to a control panel, or the formed device used to frame the video display screen.

BIDIRECTIONAL

Able to send or receive data on the same line (e.g., the data bus of a microprocessor).

BINARY

A number system that expresses all values by using two digits (0 and 1).

BIT

A binary digit; expressed as a 1 or a 0.

BLANKING

Turning off the beam on a cathode-ray tube during retrace.

BLOCK DIAGRAM

A drawing in which functional circuitry units are represented by blocks. Very useful during initial troubleshooting.

BUFFER

1. An isolating circuit designed to eliminate the reaction of a driven circuit on the circuits driving it (e.g., a buffer amplifier).

2. A device used to supply additional drive capability.

BUS

An electrical path over which information is transferred from any of several sources to any of several destinations.

CAPACITOR

A device capable of storing electrical energy. A capacitor blocks the flow of DC current while allowing AC current to pass.

CATHODE

The negative end of a diode.

CHIP

An integrated circuit comprising many circuits on a single wafer slice.

CLOCK

A repetitive timing signal for synchronizing system functions.

COINCIDENCE

Occurring at the same time.

COIN COUNTER

A 6-digit electro-mechanical device that counts the coins inserted in the coin mechanism(s).

COIN MECHANISM

A device on the inside of the coin door that inspects the coin to determine if the correct coin has been inserted.

COMPLEMENTARY

Having opposite states, such as the outputs of a flip-flop.

COMPOSITE SYNC

Horizontal and vertical synchronization pulses that are bused together into a single signal. This signal provides the timing necessary to keep the display in synchronization with the game circuitry.

COMPOSITE VIDEO

Complete video signal from the game system to drive the display circuitry, usually comprising H SYNC, V SYNC, and the video.

CREDIT

One play for one person based on the game switch settings.

CRT

Cathode-ray tube.

DATA

General term for the numbers, letters, and symbols that serve as input for device processing.

DARLINGTON

A two-transistor amplifier that provides extremely high gain.

DC

Direct current, meaning current flowing in one direction and of a fixed value.

DEFLECTION YOKE

Electro-magnetic coils around the neck of a cathode-ray tube. One set of coils deflects the electron beam horizontally and the other set deflects the beam vertically.

DIAGNOSTICS

A programmed routine for checking circuitry. For example: the self-test is a diagnostic routine.

DIODE

A semiconductor device that conducts in only one direction.

DISCRETE

Non-integrated components, such as resistors, capacitors, and transistors.

DMA

Direct memory access. DMA is a process of accessing memory that bypasses the microprocessor logic. DMA is normally used for transferring data between the input/output ports and memory.

DOWN TIME

The period during which a game is malfunctioning or not operating correctly due to machine failure.

EAROM

Electrically alterable read-only memory (see ROM). The EAROM is a memory that can be changed by the application of high voltage.

FLYBACK

A step-up transformer used in a display to provide the high voltage.

GATE

1. A circuit with one output that responds when and only when a certain combination of pulses is present at the inputs.

2. A circuit in which one signal switches another signal on and off.

3. To control the passage of a pulse or signal.

HARNESS

A prefabricated assembly of insulated wires and terminals ready to be attached to a piece of equipment.

HEXADECIMAL

A number system using the equivalent of the decimal number 16 as a base. The symbols 0-9 and A-F are usually used.

IMPLODE

To burst inward; the inward collapse of a vacuum tube.

I/O

Input/Output.

IRQ

Interrupt request. IRQ is a control signal to the microprocessor that is generated by external logic. This signal tells the microprocessor that external logic needs attention. Depending on the program, the processor may or may not respond.

LED

The abbreviation for a light-emitting diode.

LOCKOUT COIL

Directs coins into the coin return box when there is no power to the game.

LOGIC STATE

The binary (1 or 0) value at the node of a logic element or integrated circuit during a particular time. Also called the logic level. The list below shows the voltage levels corresponding to the logic states (levels) in a TTL system.

Logic 0, Low = 0 VDC to +0.8 VDC

Grey Area (Tri-State Level) = +0.8 VDC to +2.4 VDC

Logic 1, High = +2.4 VDC to +5 VDC

MULTIPLEXER

A device that takes several low-speed inputs and combines them into one high-speed data stream for simultaneous transmission on a single line.

NMI

Non-maskable interrupt. NMI is a request for service by the microprocessor from external logic. The microprocessor cannot ignore this interrupt request.

PAGE

A subsection of memory. A read-only memory device (see ROM) is broken into discrete blocks of data. These blocks are called pages. Each block has X number of bytes.

PCB

The abbreviation for a printed-circuit board.

PHOTOTRANSISTOR

A transistor that is activated by an external light source.

POTENTIOMETER

1. A resistor that has a continuously moving contact which is generally mounted on a moving shaft. Used chiefly as a voltage divider. Also called a *pot* (slang).

2. An instrument for measuring a voltage by balancing it against a known voltage.

RAM

Random-access memory. A device for the temporary storage of data.

RASTER-SCAN DISPLAY

A display system whereby images are displayed by continuously scanning the cathode-ray tube horizontally and vertically with an electron beam. The display system controls the intensity of the electron beam.

RETRACE

In a raster-scan display, retrace is the time during which the cathode-ray tube electron beam is resetting either from right to left or from bottom to top.

RESISTOR

A device designed to have a definite amount of resistance. Used in circuits to limit current flow or to provide a voltage drop.

ROM

Read-only memory. A device for the permanent storage of data.

SIGNATURE ANALYSIS

A process of isolating digital logic faults at the component level by means of special test equipment called signature analyzers. Basically, signature analyzers (e.g., the ATARI® CAT Box) convert lengthy bit

streams into four-digit hexadecimal signatures. The signature read by the analyzer at each circuit node is then compared with the known good signature for that node. This process continues until a fault is located.

TROUBLESHOOT

The process of locating and repairing a fault.

VECTOR

A line segment drawn between specific X and Y coordinates on a cathode-ray tube.

WATCHDOG

A counter circuit designed to protect the microprocessor from self-destruction if a program malfunction occurs. If a malfunction does occur, the counter applies continuous pulses to the reset line of the microprocessor, which causes the microprocessor to keep resetting.

X-Y DISPLAY

A display system whereby images are displayed with vectors.

ZENER DIODE

A special diode used as a regulator. Its main characteristic is breaking down at a specified reverse-bias (Zener) voltage.

Warranty

Seller warrants that its printed-circuit boards and parts thereon are free from defects in material and workmanship under normal use and service for a period of ninety (90) days from date of shipment. Seller warrants that its video displays (in games supplied with displays) are free from defects in material and workmanship under normal use and service for a period of thirty (30) days from date of shipment. None of the Seller's other products or parts thereof are warranted.

If the products described in this manual fail to conform to this warranty, Sellers' sole liability shall be, at its option, to repair, replace, or credit Buyer's account for such products which are returned to Seller during said warranty period, provided:

- (a) Seller is promptly notified in writing upon discovery by Buyer that said products are defective;
- (b) Such products are returned prepaid to Sellers' plant; and
- (c) Seller's examination of said products discloses to Seller's satisfaction that such alleged defects existed and were not caused by accident, misuse, neglect, alteration, improper repair, installation or improper testing.

In no event shall Seller be liable for loss of profits, loss of use, incidental or consequential damages.

Except for any express warranty set forth in a written contract between Seller and Buyer which contract supersedes the terms of this order, this warranty is expressed in lieu of all other warranties expressed or implied, including the implied warranties of merchantability and fitness for a particular purpose, and of all other obligations or liabilities on the Seller's part, and it neither assumes nor authorizes any other person to assume for the Seller any other liabilities in connection with the sale of products under this order.

The use of any non-Atari parts may void your warranty, according to the terms of the warranty. The use of any non-Atari parts may also adversely affect the safety of your game and cause injury to yourself and others. Be very cautious in using non-Atari-supplied components with our games, in order to insure your safety.

Atari distributors are independent, being privately owned and operated. In their judgment they may sell parts or accessories other than Atari parts or accessories. Atari cannot be responsible for the quality, suitability or safety of any non-Atari part or any modification including labor which is performed by such distributor.

This document is and contains confidential trade secret information of Atari, Inc.

This document is loaned under confidential custody for the sole purpose of operation, maintenance or repair of Atari equipment and may not be used by or disclosed to any person for any other purpose whatever, and remains the property of Atari, Inc.

Neither it nor the information it contains may be reproduced, used, or disclosed to persons not having a need to know consistent with the purpose of the loan, without written consent of Atari, Inc.

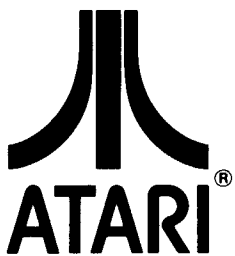
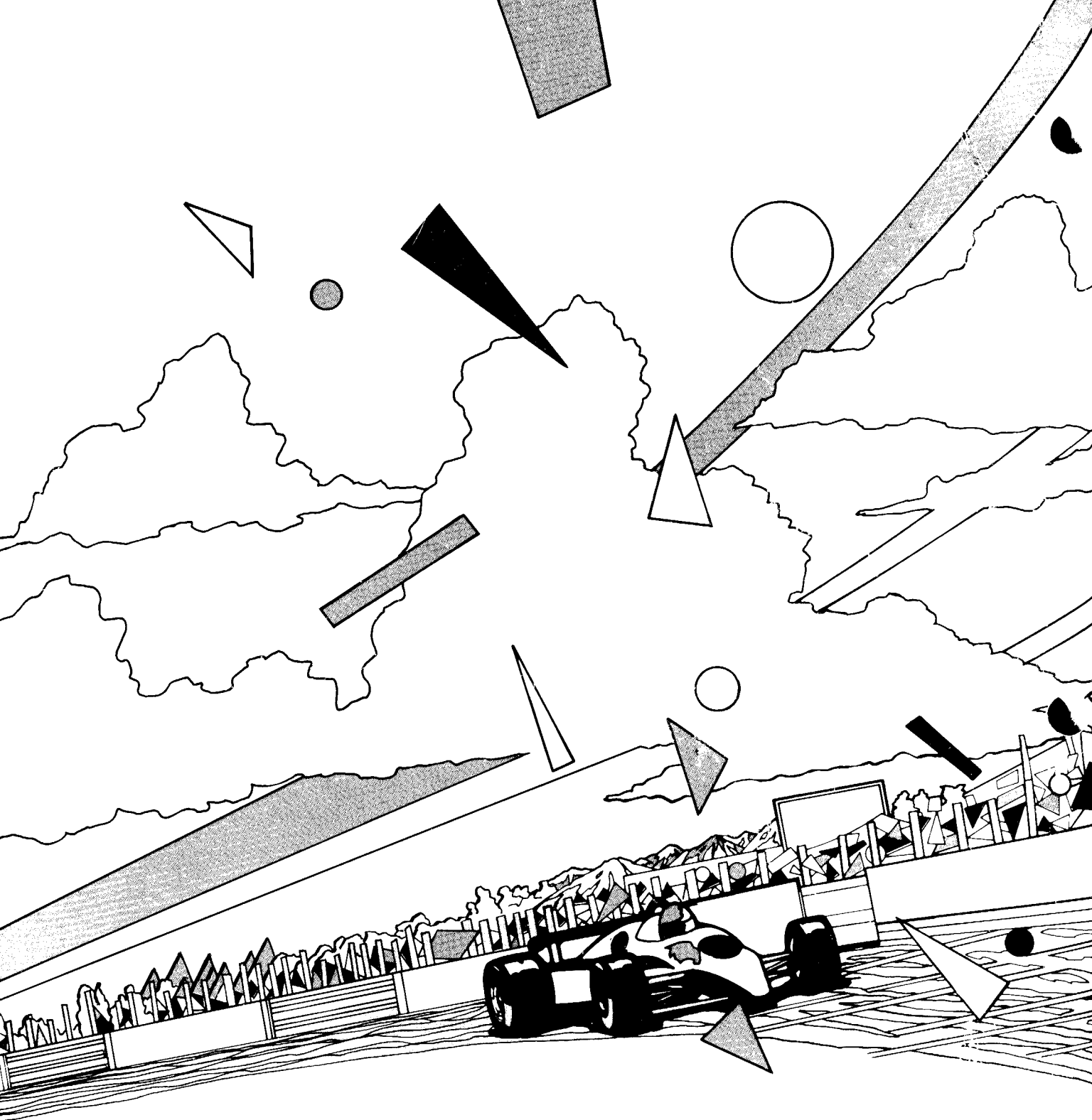

ATARI, INC.
790 SYCAMORE DRIVE
P.O. BOX 906
MILPITAS, CALIFORNIA 95035
408/942-3100 • TELEX 35-7488



A Warner Communications Company