

# TOOBIN'

## Schematic Package

Supplement to the Operators Manual

### Table of Contents

Faulty RAM/ROM Tables.....	Sheet 1
Toobin'™ Game PCB Assembly Schematic Diagram.....	Sheets 1-16
Toobin' Memory Map.....	Sheet 17
Toobin' Main Wiring Diagram.....	Sheet 18
Stand-Alone Audio PCB Assembly Schematic Diagram.....	Sheet 19-22
Wiring Diagrams for Switching/Linear (SL) Power Supply, Hitron 5V 10A Switching Power Supply, and Coin Door.....	Sheet 23



**NOTE** This staple temporarily holds the schematic package together. Remove the staple when you use the schematics.



Atari Games Corporation • P.O. Box 361110 • Milpitas, CA 95035 • (408) 434-3950 • Telex 5101007850



# Faulty RAM/ROM Tables

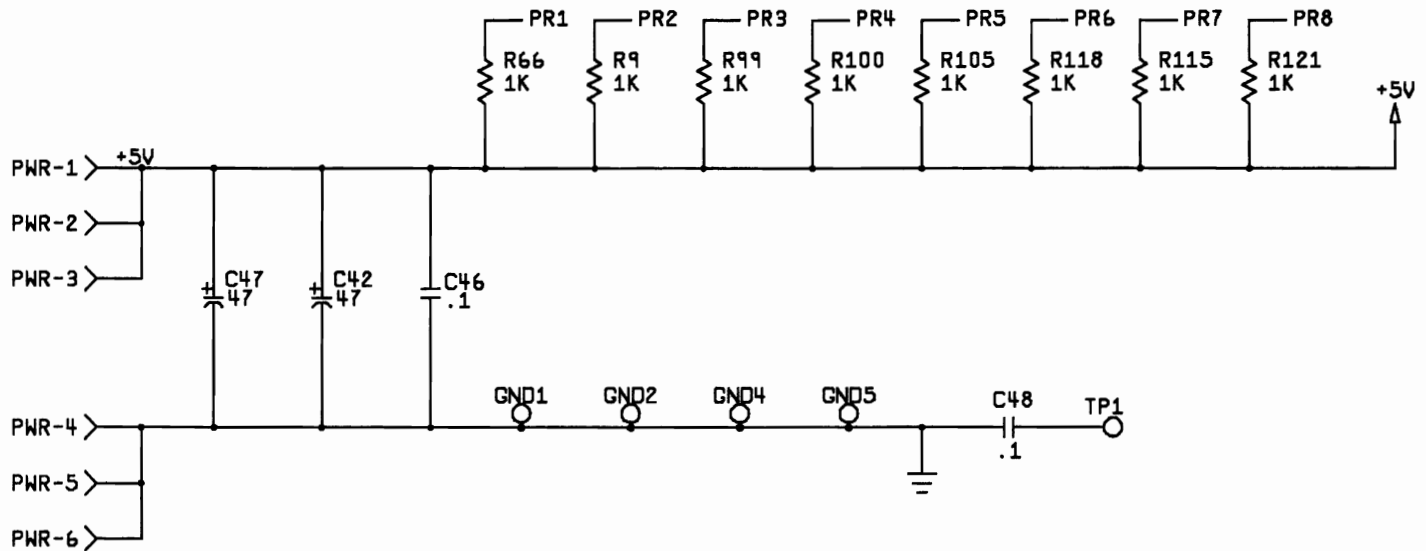

**Table 1 Faulty RAM Locations**

Ram Type	Location	Video Display Characteristic
CPU	7J, 7F	Background color is red.
PF	1E, 3E, 4/5E	Background color is green.
AL/MO	17D, 18D	Background color is blue.
COL	8J, 9J	Background color varies between red, white, and blue.

**Table 2 Faulty ROM Locations**

Error Address	Location on Game PCB	
00000	U = 1J	L = 1F
20000	U = 2J	L = 2F
40000	U = 4J	L = 4F
60000	U = 5J	L = 5F

**NOTICE TO ALL PERSONS RECEIVING THIS DRAWING**  
 CONFIDENTIAL: Reproduction forbidden without the specific written permission of Atari Games Corporation, Milpitas, CA. This drawing is only conditionally issued and neither receipt nor possession thereof confers or transfers any right in, or license to use, the subject matter of the drawing or any design or technical information shown thereon, nor any right to reproduce this drawing, or any part thereof. Except for manufacture by vendors of Atari Games Corporation, and for manufacture under the corporation's written license, no right is granted to reproduce this drawing or the subject matter thereof, unless by written agreement with or written permission from the corporation.

**Toobin™ Game PCB Assembly Schematic Diagram, Faulty RAM/ROM Tables**



SP-320 Sheet 1  
1st printing

© 1988 Atari Games Corporation

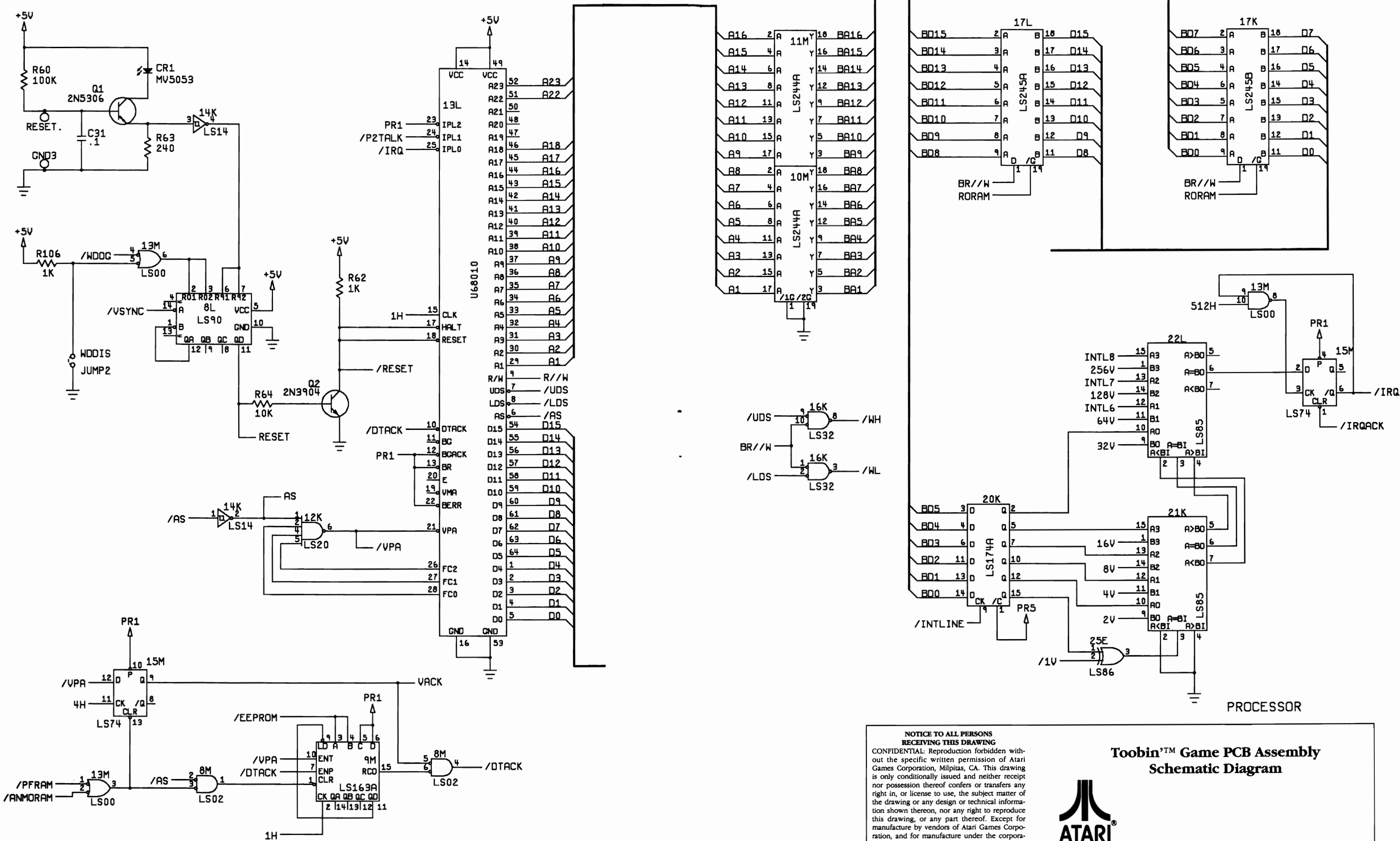

**NOTICE TO ALL PERSONS RECEIVING THIS DRAWING**  
CONFIDENTIAL. Reproduction forbidden without the specific written permission of Atari Games Corporation, Milpitas, CA. This drawing is only conditionally issued and neither receipt nor possession thereof confers or transfers any right in, or license to use, the subject matter of the drawing or any design or technical information shown thereon, nor any right to reproduce this drawing, or any part thereof. Except for manufacture by vendors of Atari Games Corporation, and for manufacture under the corporation's written license, no right is granted to reproduce this drawing or the subject matter thereof, unless by written agreement with or written permission from the corporation.

**Toobin™ Game PCB Assembly Schematic Diagram**

**ATARI GAMES**

© 1988 Atari Games Corporation  
044402-xx A

**SP-320 Sheet 2 1st printing**

Not Stuffed

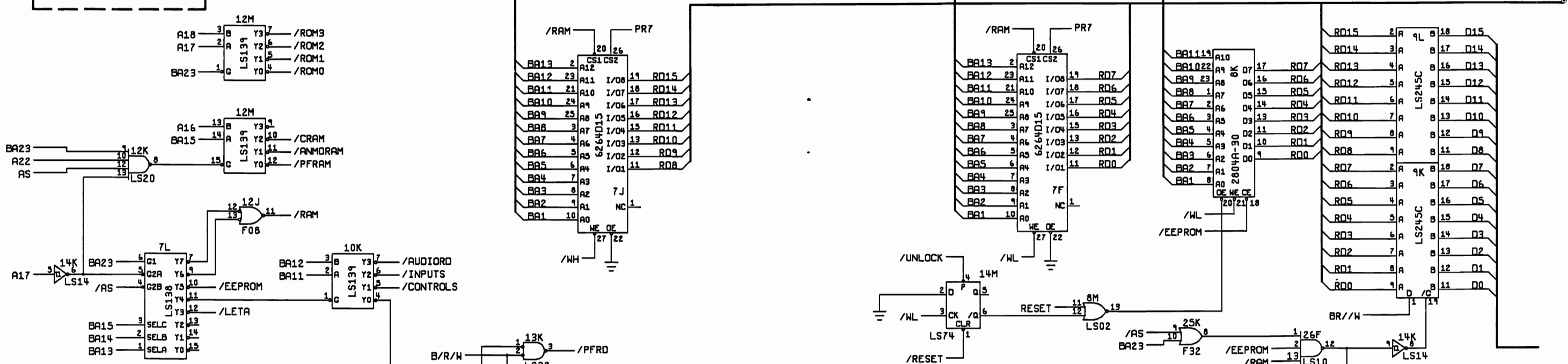
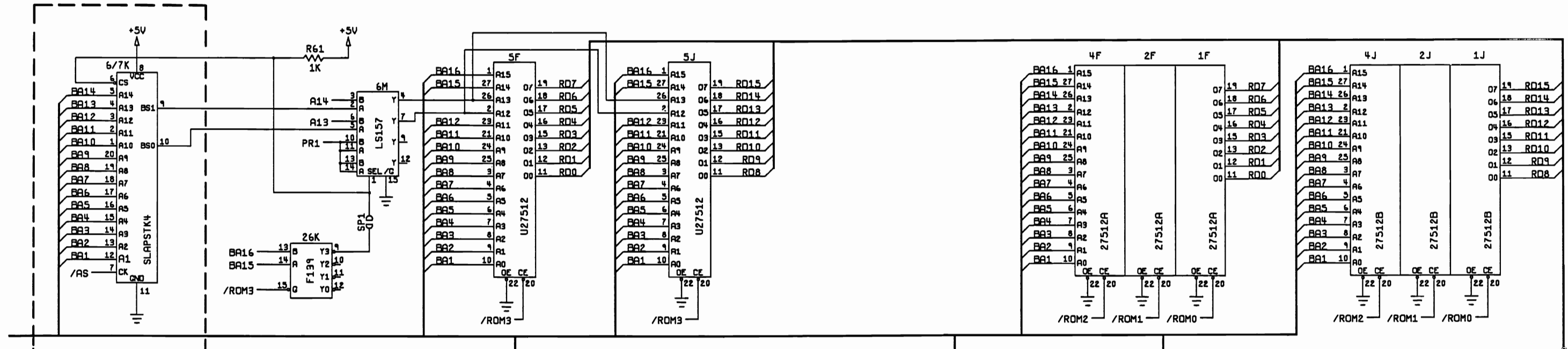

RAM, ROM, ADDRESS DECODES



**NOTICE TO ALL PERSONS RECEIVING THIS DRAWING**  
 CONFIDENTIAL: Reproduction forbidden without the specific written permission of Atari Games Corporation, Milpitas, CA. This drawing is only conditionally issued and neither receipt nor possession thereof confers or transfers any right in, or license to use, the subject matter of the drawing or any design or technical information shown thereon, nor any right to reproduce this drawing, or any part thereof. Except for manufacture by vendors of Atari Games Corporation, and for manufacture under the corporation's written license, no right is granted to reproduce this drawing or the subject matter thereof, unless by written agreement with or written permission from the corporation.

**Toobin™ Game PCB Assembly Schematic Diagram**

ATARI GAMES

© 1988 Atari Games Corporation

SP-320 Sheet 3  
1st printing

044402-xx A

Not Stuffed

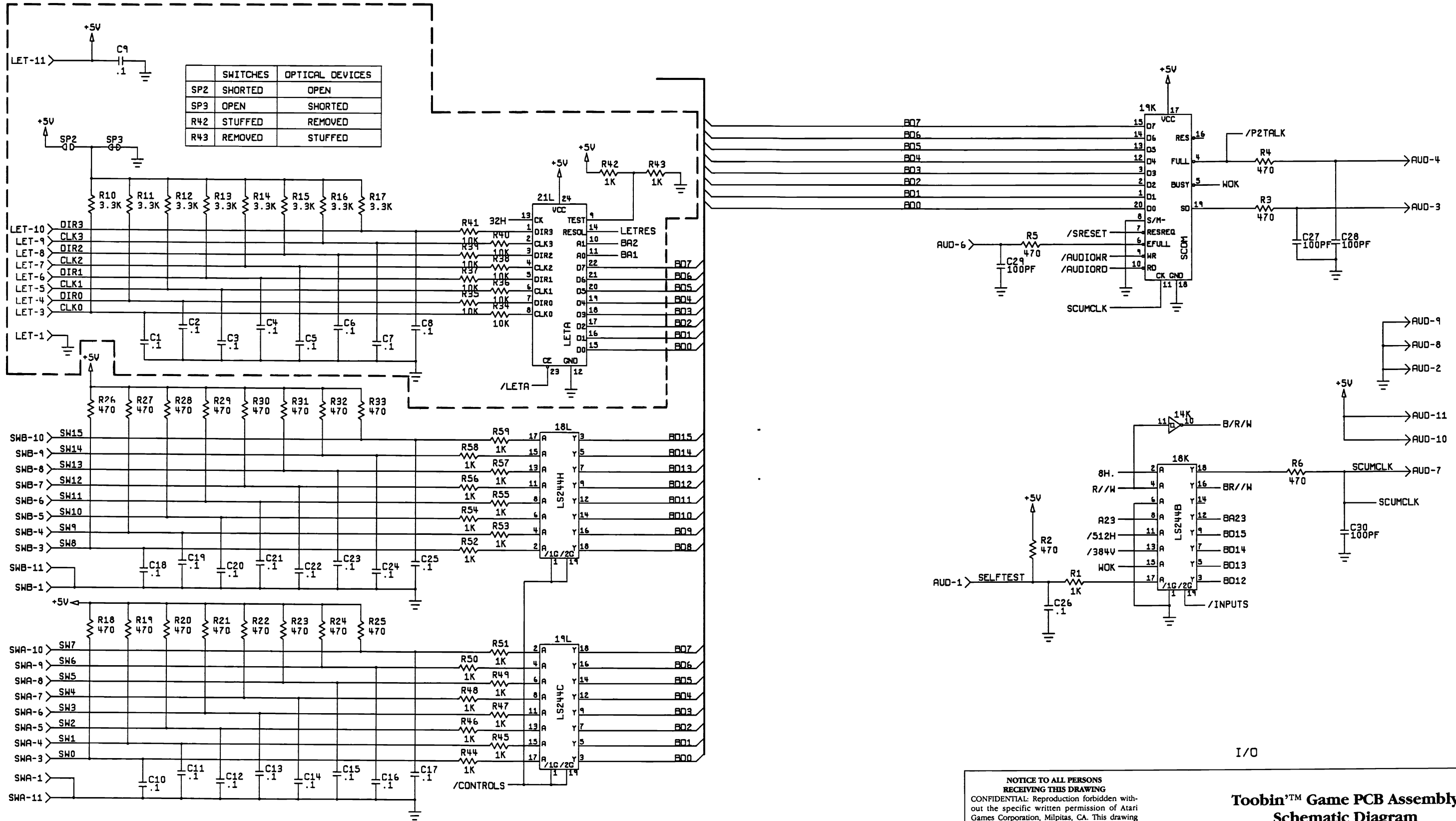

**NOTICE TO ALL PERSONS RECEIVING THIS DRAWING**  
 CONFIDENTIAL: Reproduction forbidden without the specific written permission of Atari Games Corporation, Milpitas, CA. This drawing is only conditionally issued and neither receipt nor possession thereof confers or transfers any right in, or license to use, the subject matter of the drawing or any design or technical information shown thereon, nor any right to reproduce this drawing, or any part thereof. Except for manufacture by vendors of Atari Games Corporation, and for manufacture under the corporation's written license, no right is granted to reproduce this drawing or the subject matter thereof, unless by written agreement with or written permission from the corporation.

**Toobin™ Game PCB Assembly Schematic Diagram**



© 1988 Atari Games Corporation

SP-320 Sheet 4  
1st printing

044402-xx A

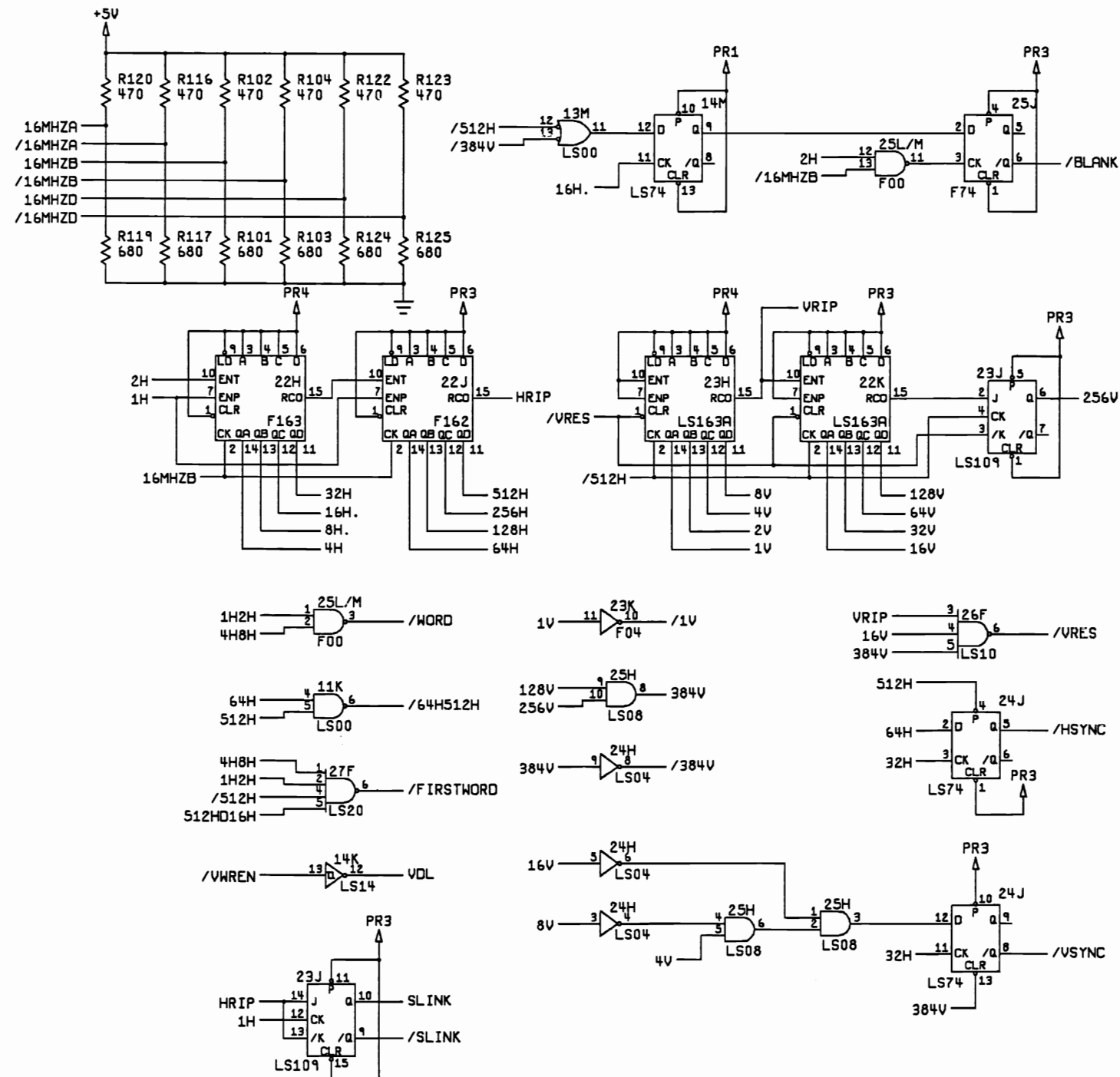
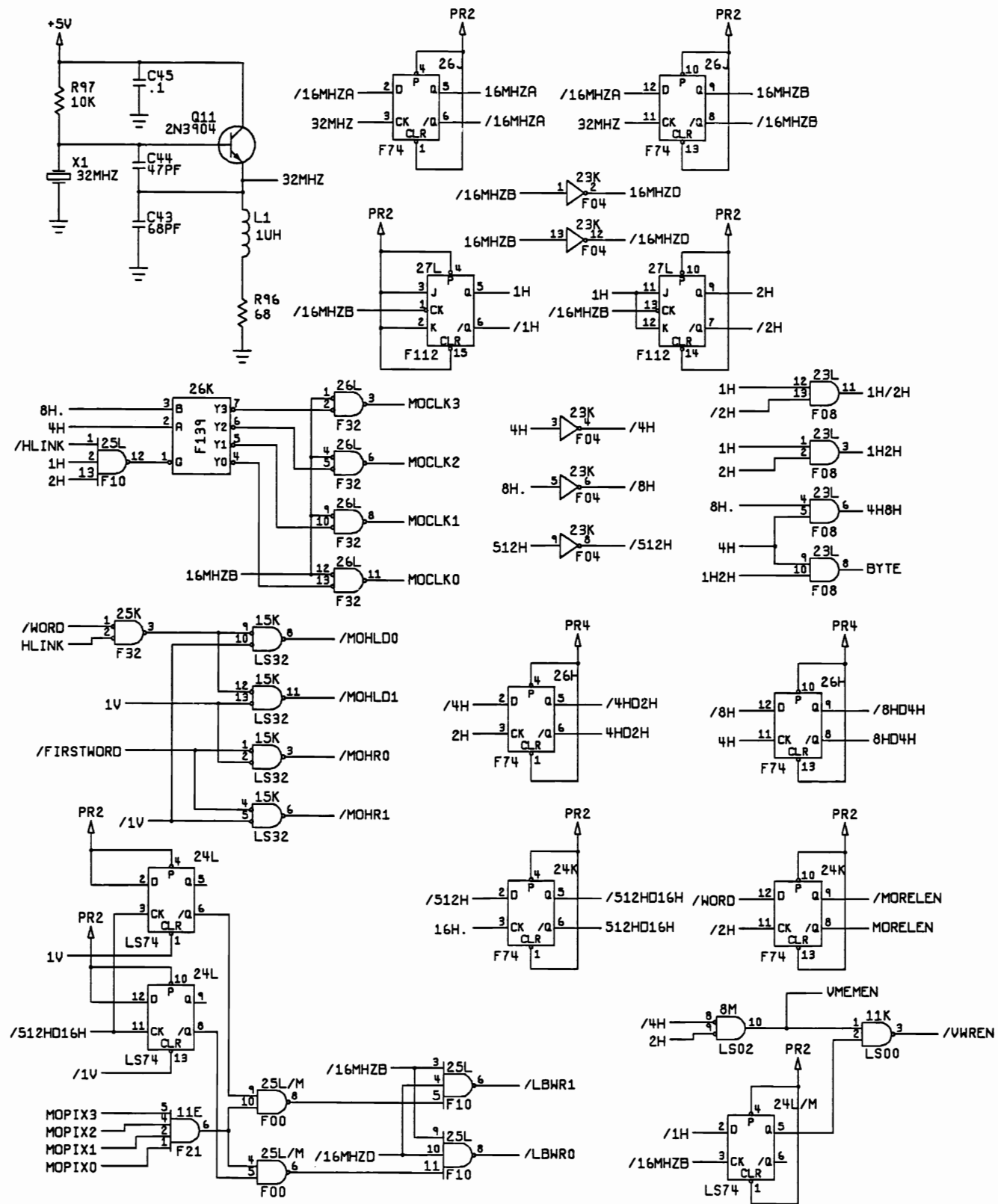

SYNC, TIMING

**NOTICE TO ALL PERSONS RECEIVING THIS DRAWING**  
 CONFIDENTIAL: Reproduction forbidden without the specific written permission of Atari Games Corporation, Milpitas, CA. This drawing is only conditionally issued and neither receipt nor possession thereof confers or transfers any right in, or license to use, the subject matter of the drawing or any design or technical information shown thereon, nor any right to reproduce this drawing, or any part thereof. Except for manufacture by vendors of Atari Games Corporation, and for manufacture under the corporation's written license, no right is granted to reproduce this drawing or the subject matter thereof, unless by written agreement with or written permission from the corporation.

**Toobin™ Game PCB Assembly Schematic Diagram**

**ATARI GAMES**

© 1988 Atari Games Corporation

SP-320 Sheet 5  
1st printing

044402-xx A

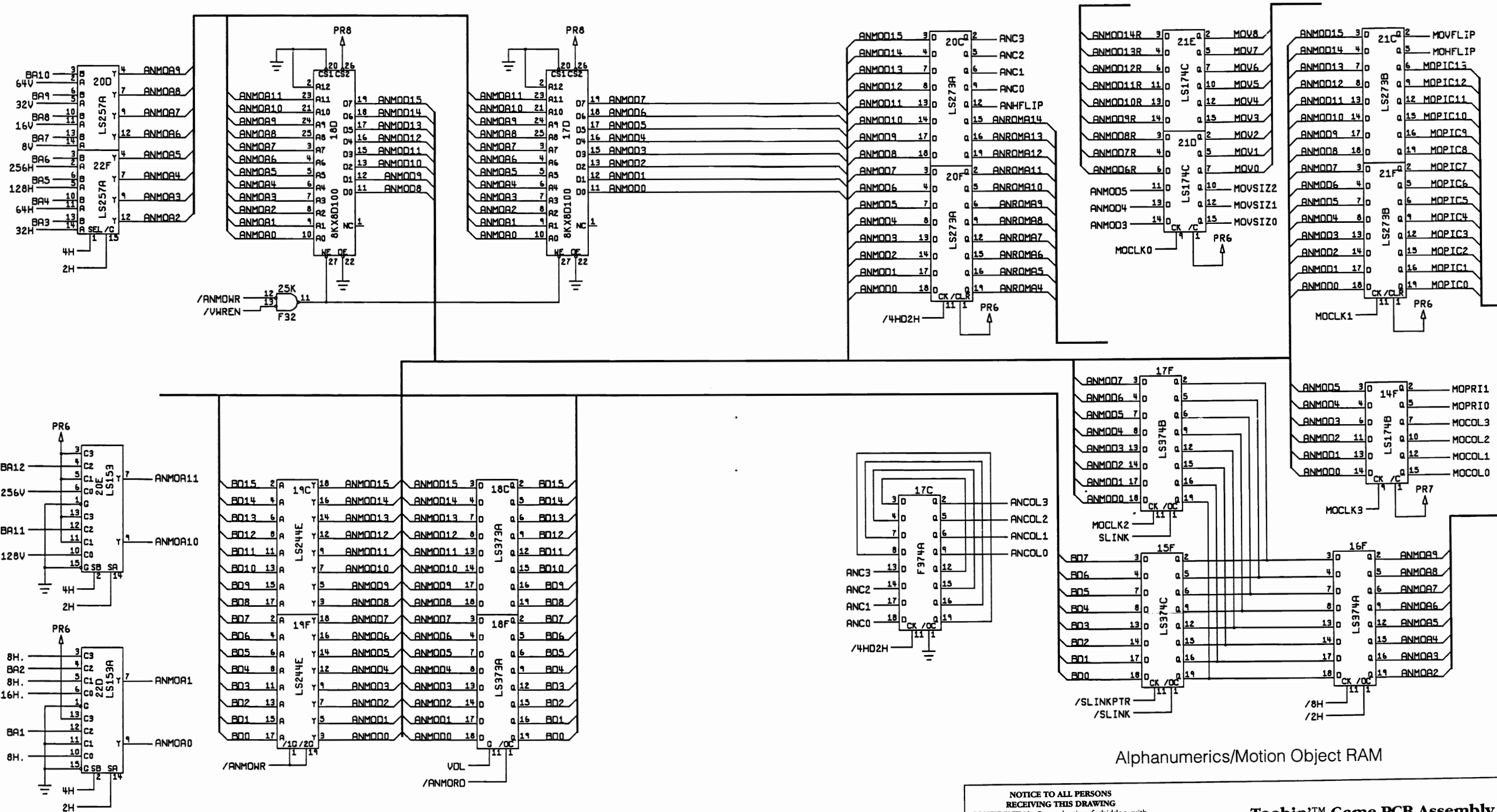

Alphanumerics/Motion Object RAM

**NOTICE TO ALL PERSONS RECEIVING THIS DRAWING**  
 CONFIDENTIAL: Reproduction forbidden without the specific written permission of Atari Games Corporation, Milpitas, CA. This drawing is only conditionally issued and neither receipt nor possession thereof confers or transfers any right in, or license to use, the subject matter of the drawing or any design or technical information shown thereon, nor any right to reproduce this drawing, or any part thereof. Except for manufacture by vendors of Atari Games Corporation, and for manufacture under the corporation's written license, no right is granted to reproduce this drawing or the subject matter thereof, unless by written agreement with or written permission from the corporation.

**Toobin™ Game PCB Assembly Schematic Diagram**



**ATARI**  
GAMES

© 1988 Atari Games Corporation  
 SP-320 Sheet 6  
 1st printing  
 044402-xx A

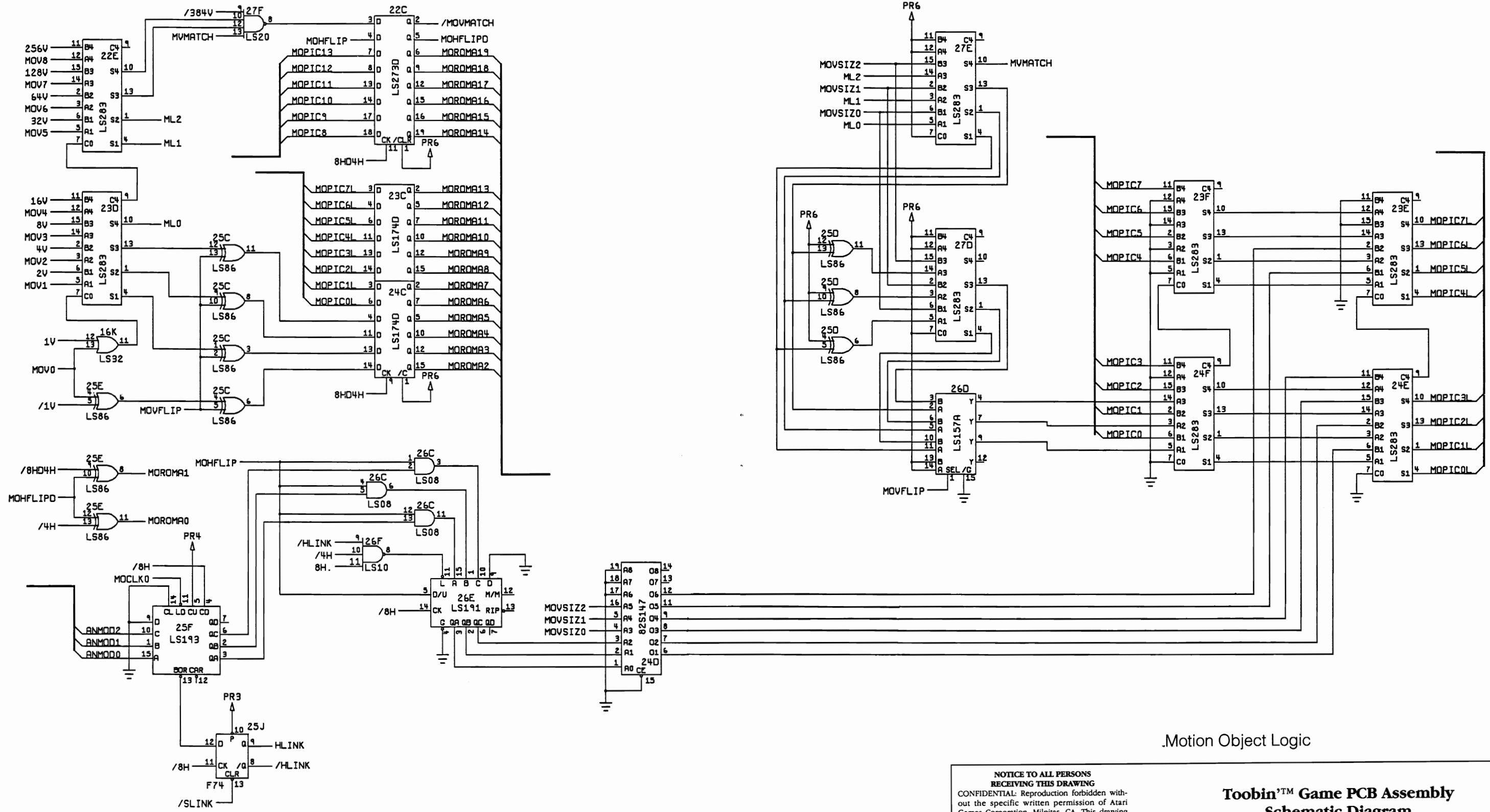

.Motion Object Logic

**NOTICE TO ALL PERSONS RECEIVING THIS DRAWING**  
 CONFIDENTIAL: Reproduction forbidden without the specific written permission of Atari Games Corporation, Milpitas, CA. This drawing is only conditionally issued and neither receipt nor possession thereof confers or transfers any right in, or license to use, the subject matter of the drawing or any design or technical information shown thereon, nor any right to reproduce this drawing, or any part thereof. Except for manufacture by vendors of Atari Games Corporation, and for manufacture under the corporation's written license, no right is granted to reproduce this drawing or the subject matter thereof, unless by written agreement with or written permission from the corporation.



**ATARI**  
GAMES

**Toobin™ Game PCB Assembly Schematic Diagram**

© 1988 Atari Games Corporation

044402-xx A

**SP-320 Sheet 7**  
1st printing



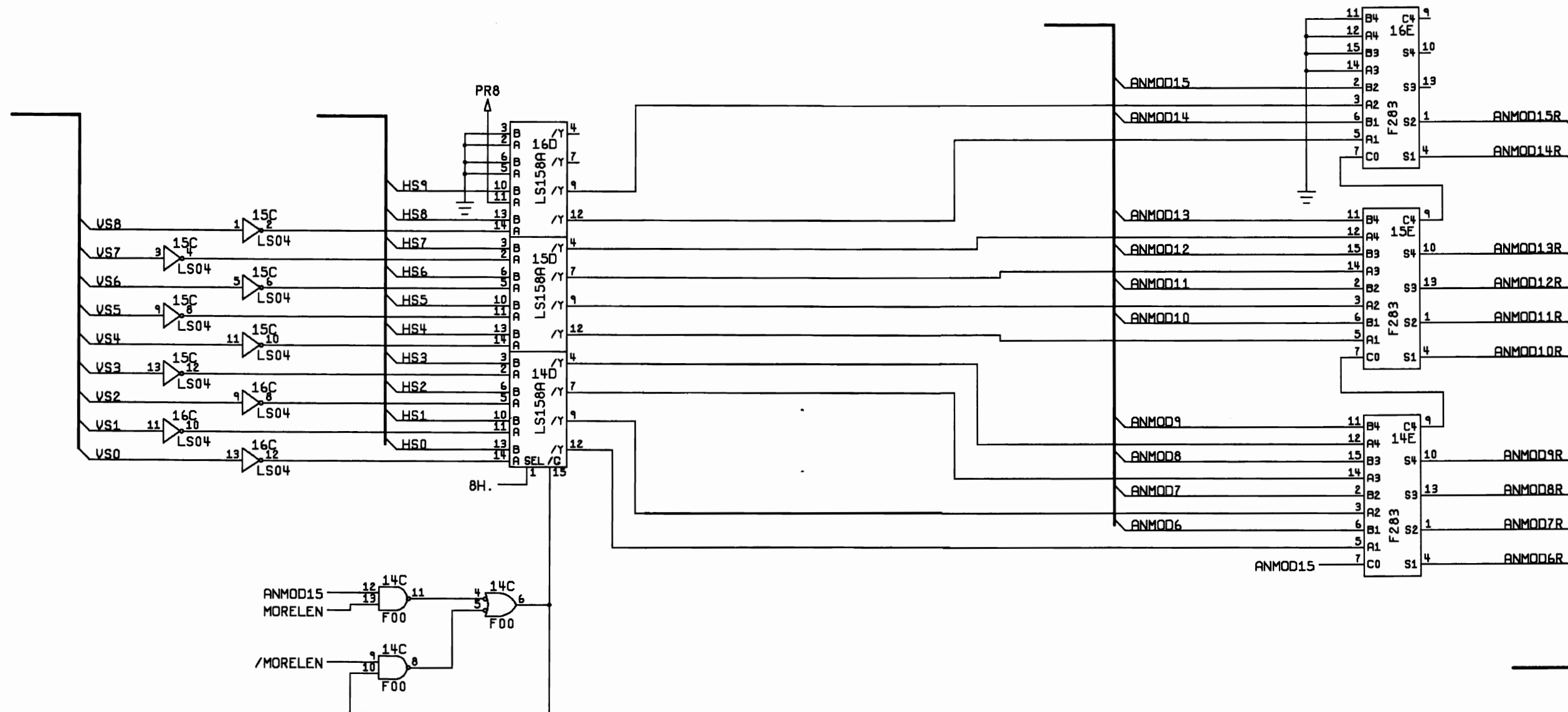

Motion Object Relative/Absolute Position Logic

**NOTICE TO ALL PERSONS RECEIVING THIS DRAWING**  
 CONFIDENTIAL: Reproduction forbidden without the specific written permission of Atari Games Corporation, Milpitas, CA. This drawing is only conditionally issued and neither receipt nor possession thereof confers or transfers any right in, or license to use, the subject matter of the drawing or any design or technical information shown thereon, nor any right to reproduce this drawing, or any part thereof. Except for manufacture by vendors of Atari Games Corporation, and for manufacture under the corporation's written license, no right is granted to reproduce this drawing or the subject matter thereof, unless by written agreement with or written permission from the corporation.

**Toobin™ Game PCB Assembly Schematic Diagram**

**ATARI GAMES**

© 1988 Atari Games Corporation  
044402-xx A

**SP-320 Sheet 8  
1st printing**

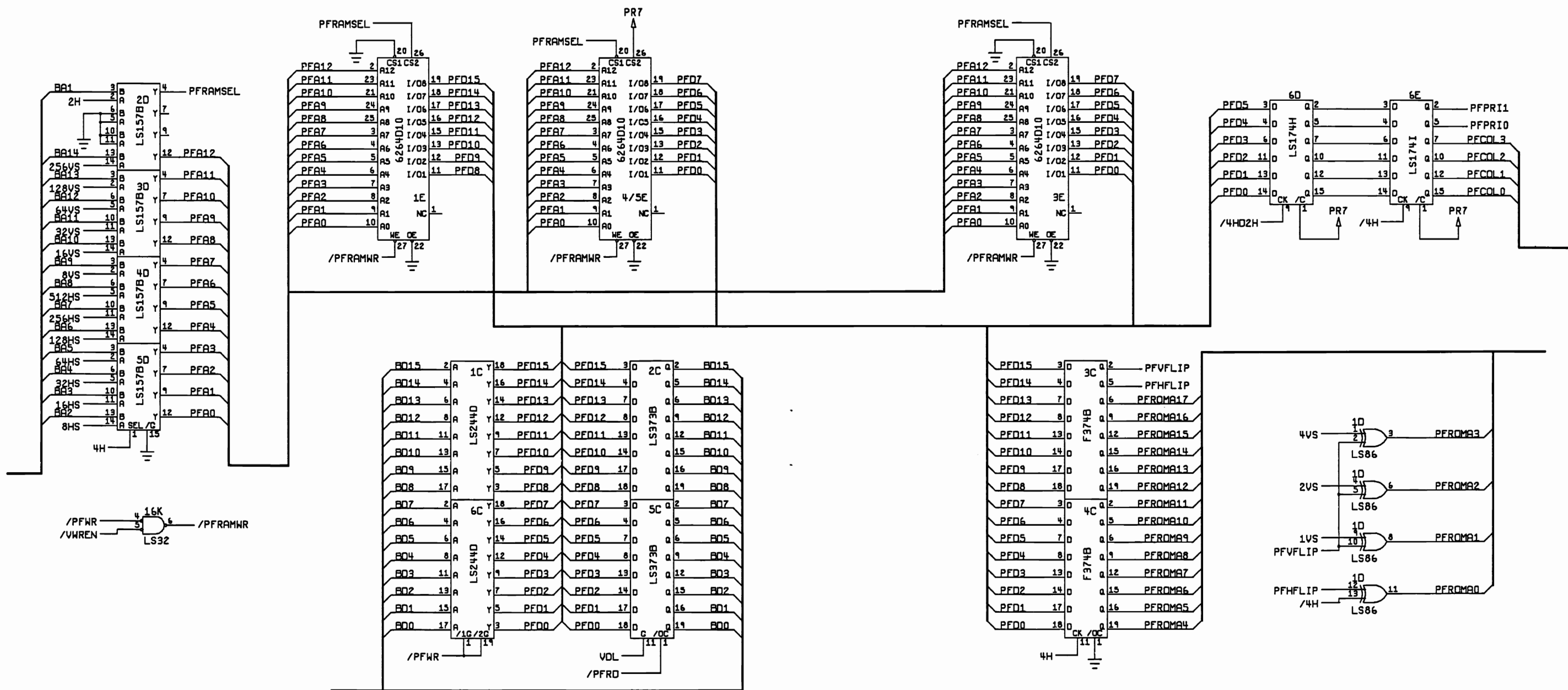

Playfield RAM

**NOTICE TO ALL PERSONS RECEIVING THIS DRAWING**  
 CONFIDENTIAL: Reproduction forbidden without the specific written permission of Atari Games Corporation, Milpitas, CA. This drawing is only conditionally issued and neither receipt nor possession thereof confers or transfers any right in, or license to use, the subject matter of the drawing or any design or technical information shown thereon, nor any right to reproduce this drawing, or any part thereof. Except for manufacture by vendors of Atari Games Corporation, and for manufacture under the corporation's written license, no right is granted to reproduce this drawing or the subject matter thereof, unless by written agreement with or written permission from the corporation.

**Toobin™ Game PCB Assembly Schematic Diagram**

© 1988 Atari Games Corporation  
 SP-320 Sheet 9  
 1st printing  
 044402-xx A

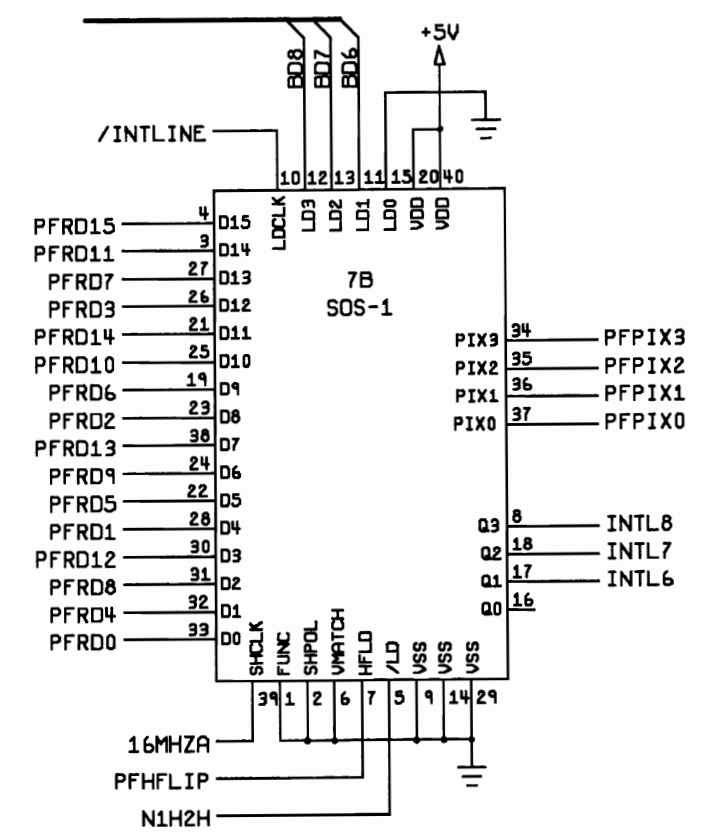
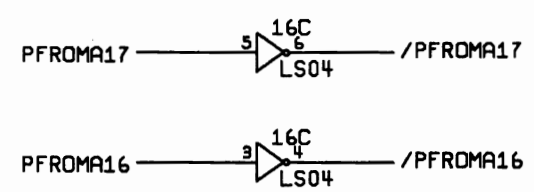
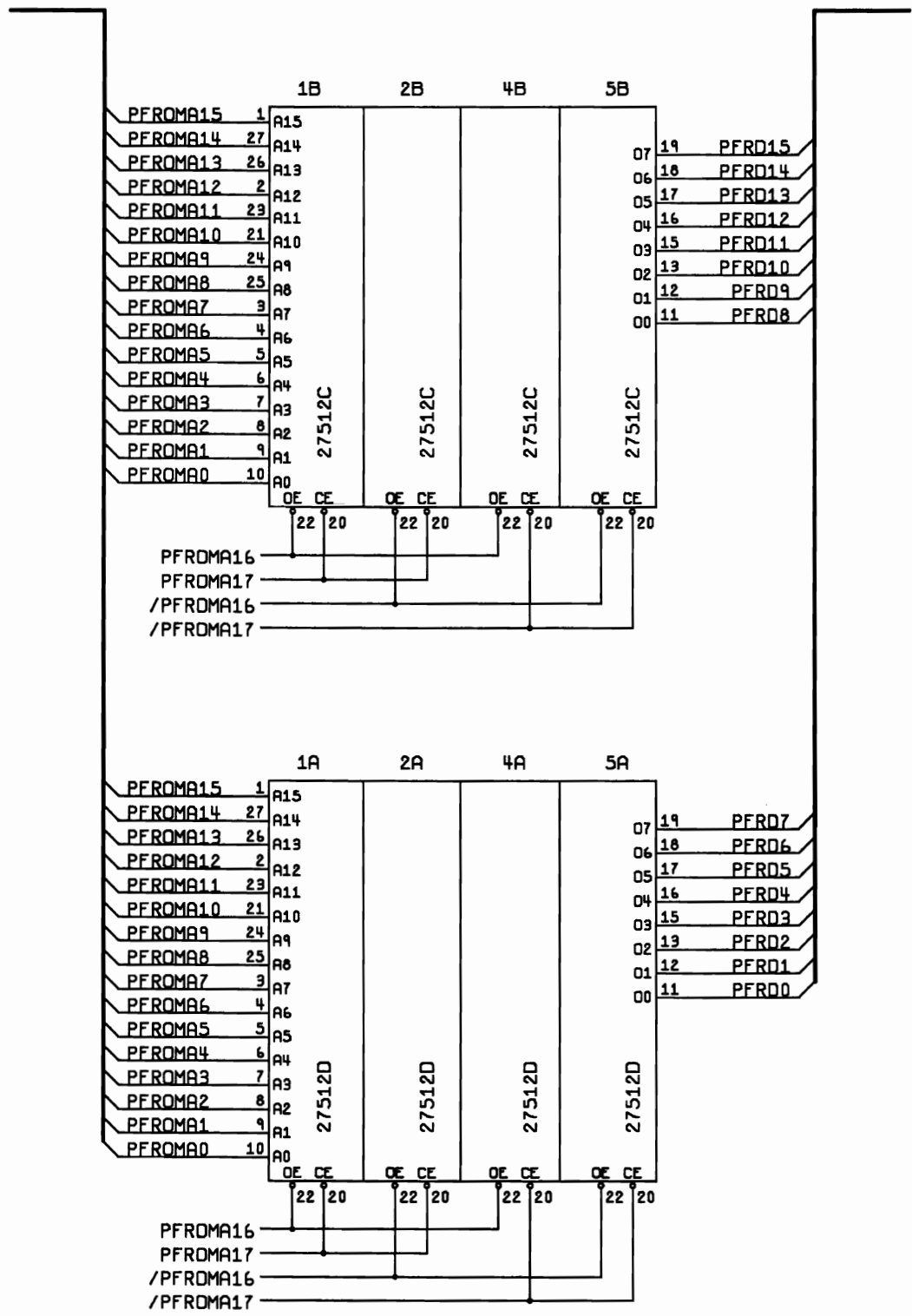

Playfield Graphics ROM, Shifter

**NOTICE TO ALL PERSONS RECEIVING THIS DRAWING**  
 CONFIDENTIAL: Reproduction forbidden without the specific written permission of Atari Games Corporation, Milpitas, CA. This drawing is only conditionally issued and neither receipt nor possession thereof confers or transfers any right in, or license to use, the subject matter of the drawing or any design or technical information shown thereon, nor any right to reproduce this drawing, or any part thereof. Except for manufacture by vendors of Atari Games Corporation, and for manufacture under the corporation's written license, no right is granted to reproduce this drawing or the subject matter thereof, unless by written agreement with or written permission from the corporation.

**Toobin™ Game PCB Assembly Schematic Diagram**

**ATARI GAMES**

© 1988 Atari Games Corporation

SP-320 Sheet 10  
1st printing

044402-xx A

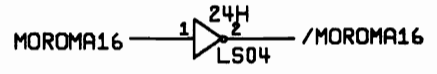
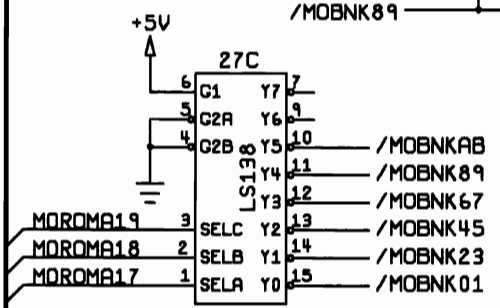
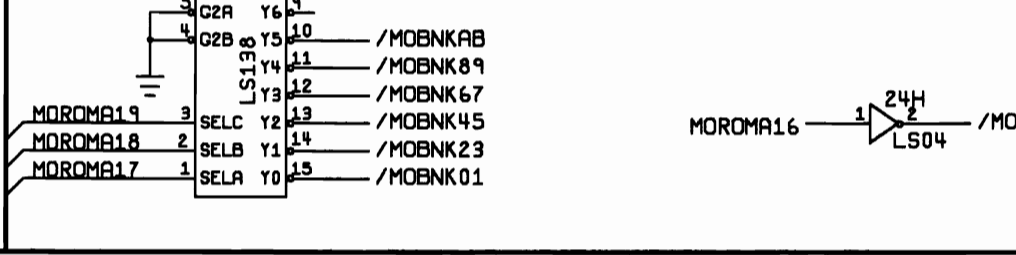
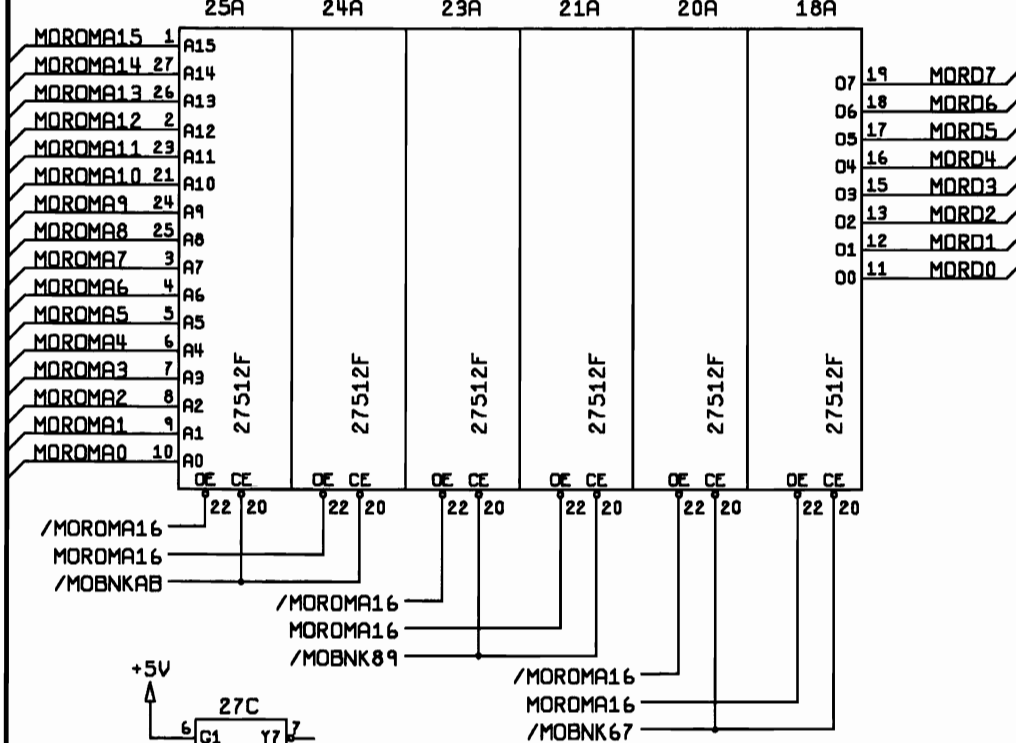
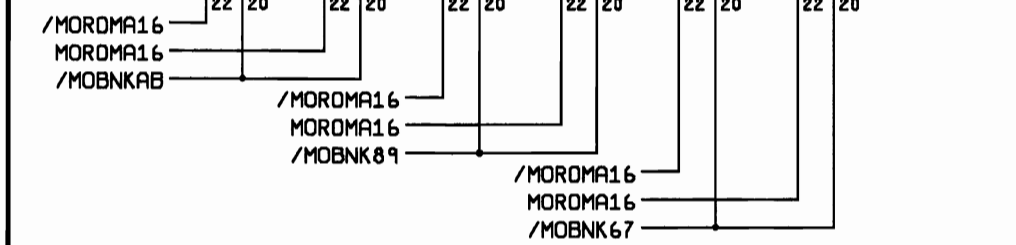
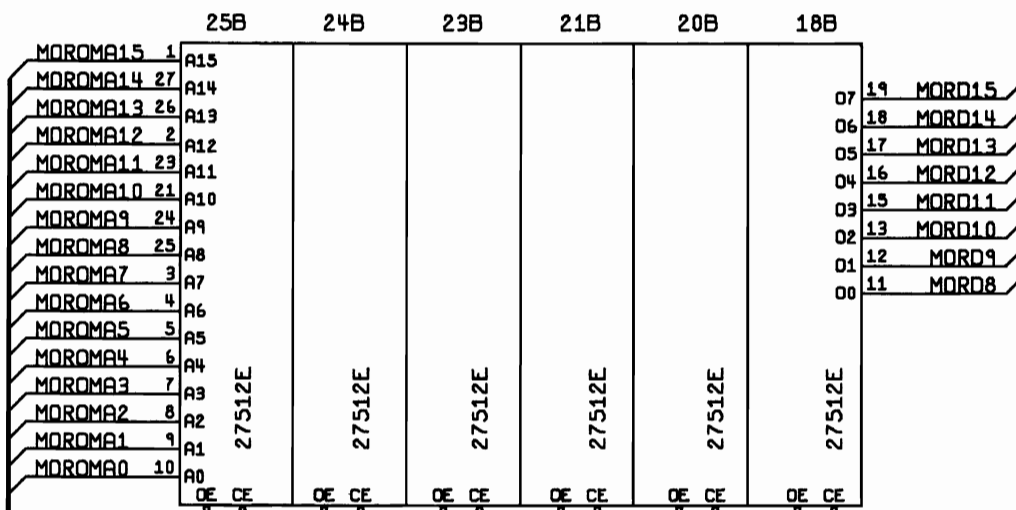

Motion Object Graphics ROM

**NOTICE TO ALL PERSONS RECEIVING THIS DRAWING**  
 CONFIDENTIAL: Reproduction forbidden without the specific written permission of Atari Games Corporation, Milpitas, CA. This drawing is only conditionally issued and neither receipt nor possession thereof confers or transfers any right in, or license to use, the subject matter of the drawing or any design or technical information shown thereon, nor any right to reproduce this drawing, or any part thereof. Except for manufacture by vendors of Atari Games Corporation, and for manufacture under the corporation's written license, no right is granted to reproduce this drawing or the subject matter thereof, unless by written agreement with or written permission from the corporation.

**Toobin™ Game PCB Assembly Schematic Diagram**

© 1988 Atari Games Corporation  
 SP-320 Sheet 11  
 1st printing  
 044402-xx A

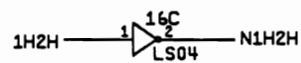
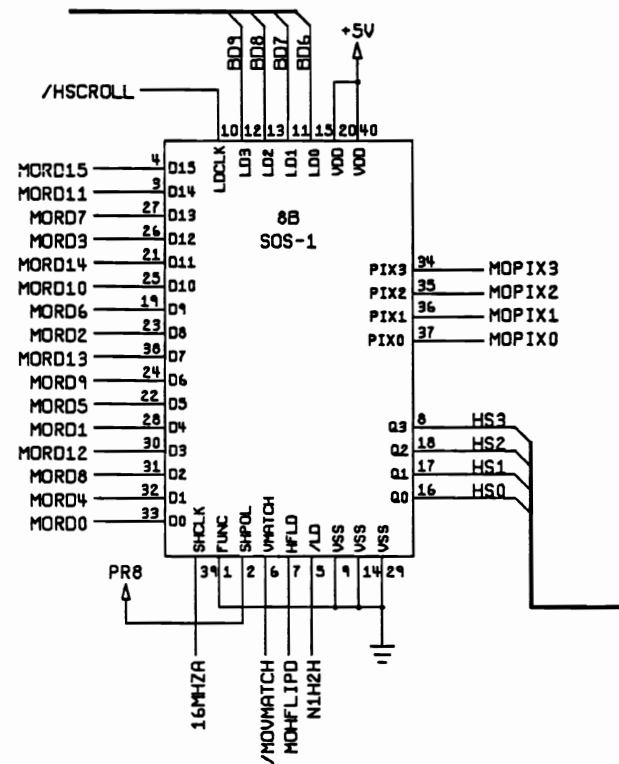
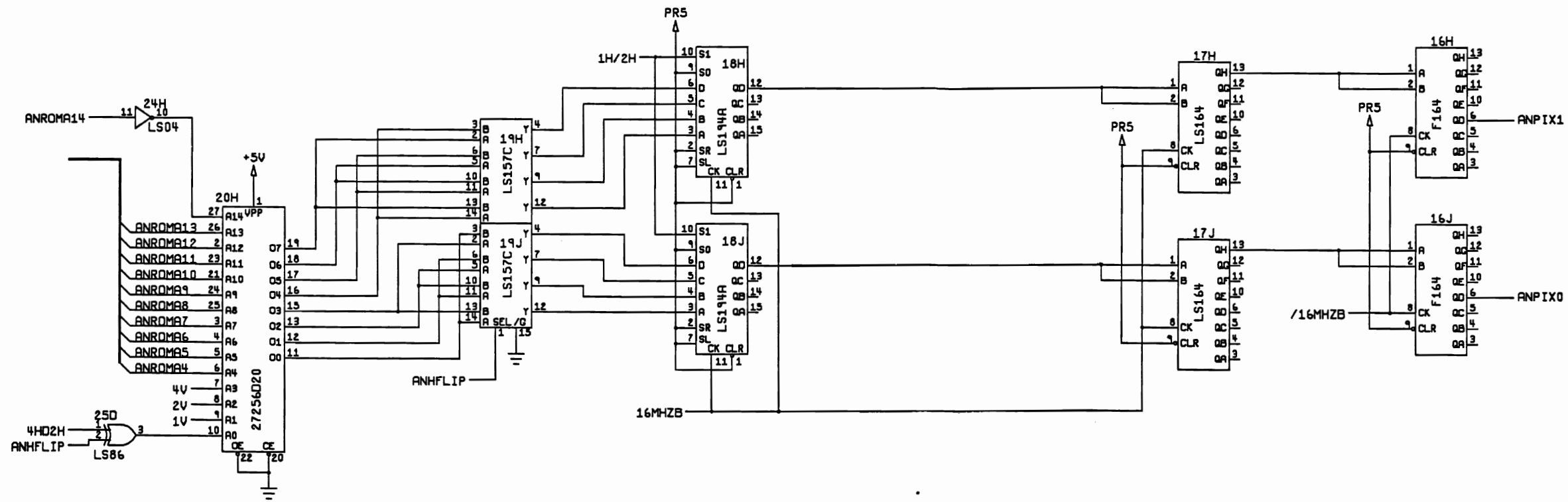

Alphanumerics ROM, Motion Object Shifter

**NOTICE TO ALL PERSONS RECEIVING THIS DRAWING**

CONFIDENTIAL: Reproduction forbidden without the specific written permission of Atari Games Corporation, Milpitas, CA. This drawing is only conditionally issued and neither receipt nor possession thereof confers or transfers any right in, or license to use, the subject matter of the drawing or any design or technical information shown thereon, nor any right to reproduce this drawing, or any part thereof. Except for manufacture by vendors of Atari Games Corporation, and for manufacture under the corporation's written license, no right is granted to reproduce this drawing or the subject matter thereof, unless by written agreement with or written permission from the corporation.

**Toobin™ Game PCB Assembly Schematic Diagram**



© 1988 Atari Games Corporation

SP-320 Sheet 12  
1st printing

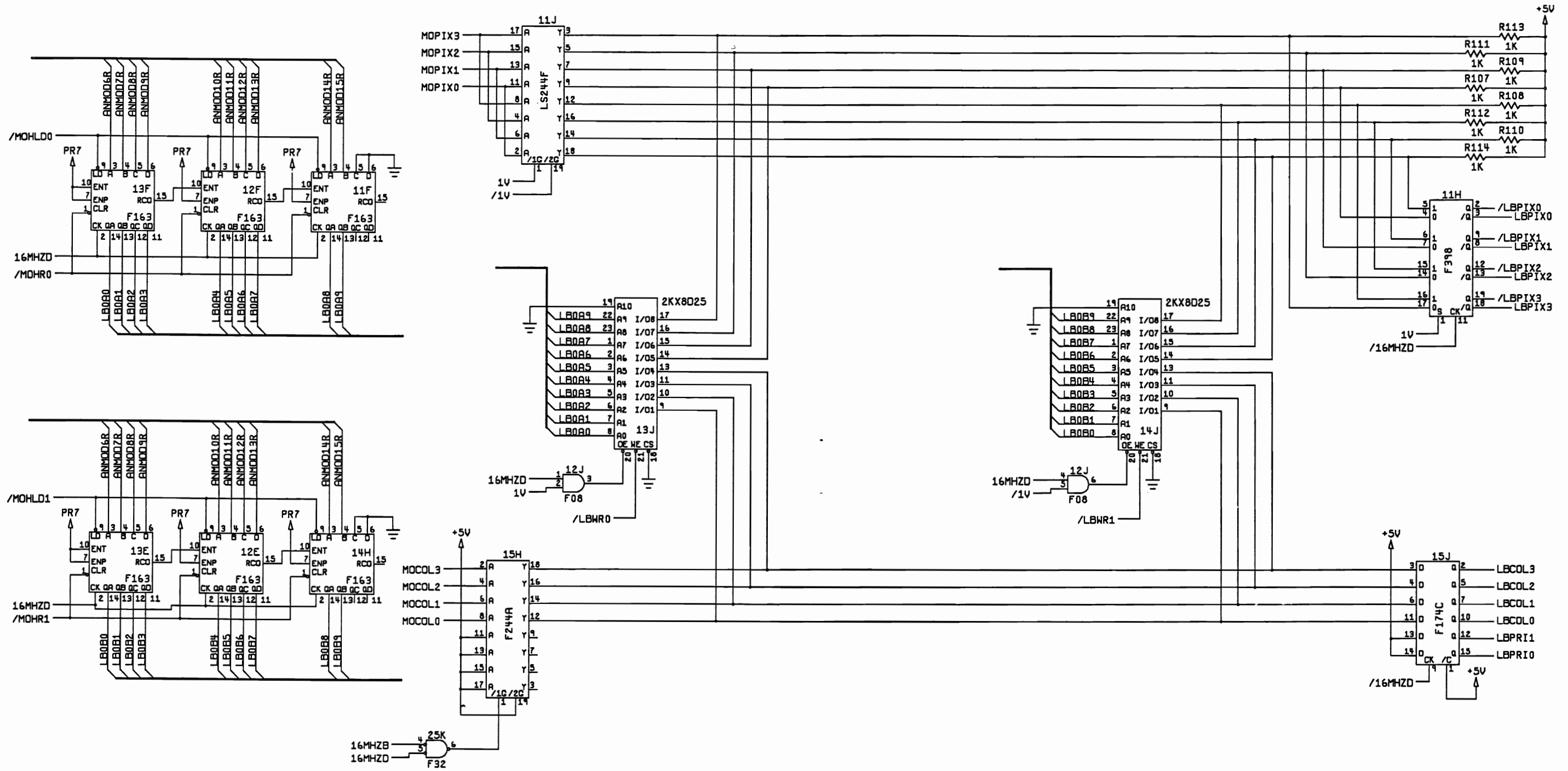

Motion Object Line Buffers

**NOTICE TO ALL PERSONS RECEIVING THIS DRAWING**  
 CONFIDENTIAL: Reproduction forbidden without the specific written permission of Atari Games Corporation, Milpitas, CA. This drawing is only conditionally issued and neither receipt nor possession thereof confers or transfers any right in, or license to use, the subject matter of the drawing or any design or technical information shown thereon, nor any right to reproduce this drawing, or any part thereof. Except for manufacture by vendors of Atari Games Corporation, and for manufacture under the corporation's written license, no right is granted to reproduce this drawing or the subject matter thereof, unless by written agreement with or written permission from the corporation.

**Toobin™ Game PCB Assembly Schematic Diagram**

**ATARI GAMES**

© 1988 Atari Games Corporation  
044402-xx A

**SP-320 Sheet 13  
1st printing**

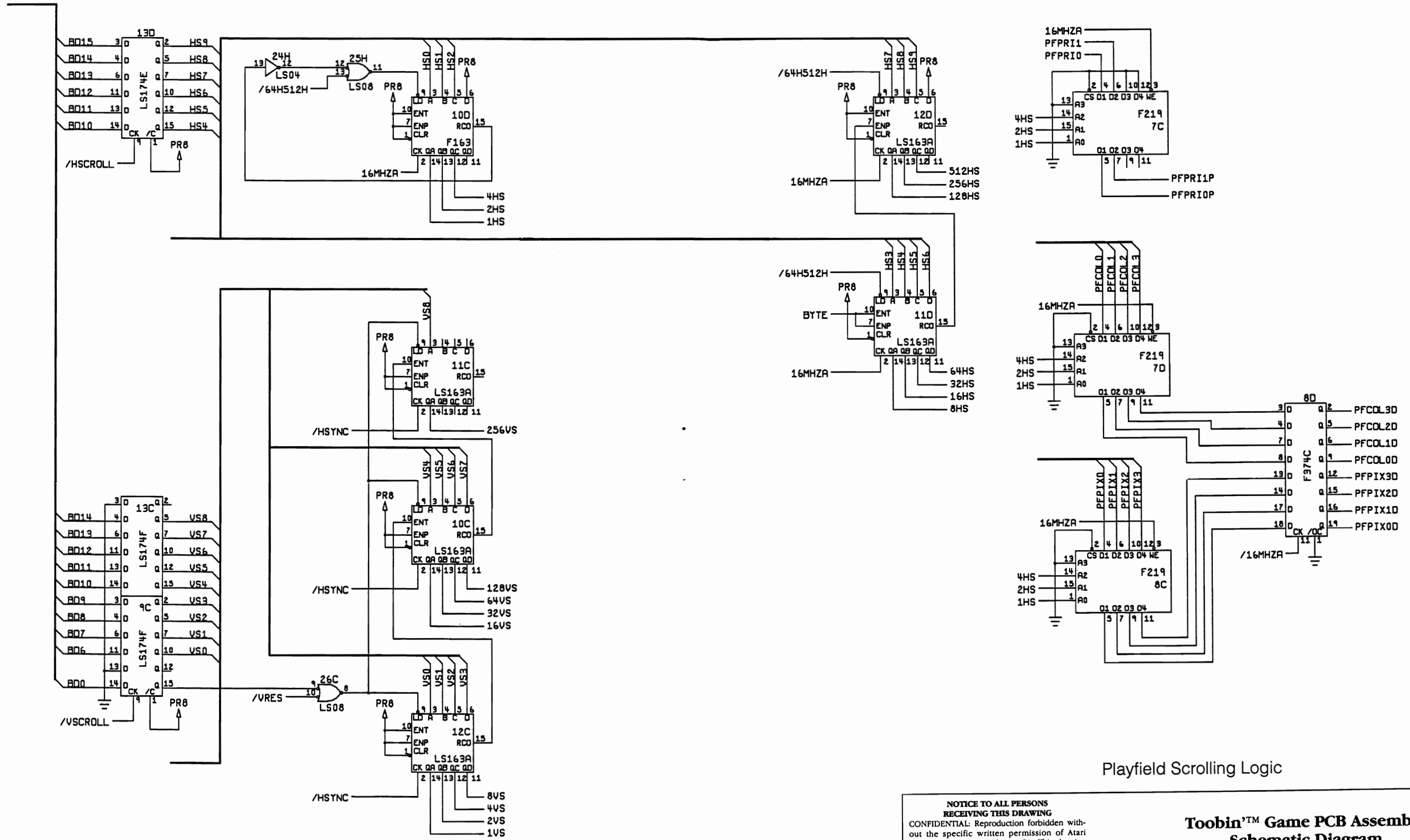

Playfield Scrolling Logic

**NOTICE TO ALL PERSONS RECEIVING THIS DRAWING**  
 CONFIDENTIAL: Reproduction forbidden without the specific written permission of Atari Games Corporation, Milpitas, CA. This drawing is only conditionally issued and neither receipt nor possession thereof confers or transfers any right in, or license to use, the subject matter of the drawing or any design or technical information shown thereon, nor any right to reproduce this drawing, or any part thereof. Except for manufacture by vendors of Atari Games Corporation, and for manufacture under the corporation's written license, no right is granted to reproduce this drawing or the subject matter thereof, unless by written agreement with or written permission from the corporation.

**Toobin™ Game PCB Assembly Schematic Diagram**

**ATARI GAMES**

© 1988 Atari Games Corporation  
044402-xx A

SP-320 Sheet 14  
1st printing

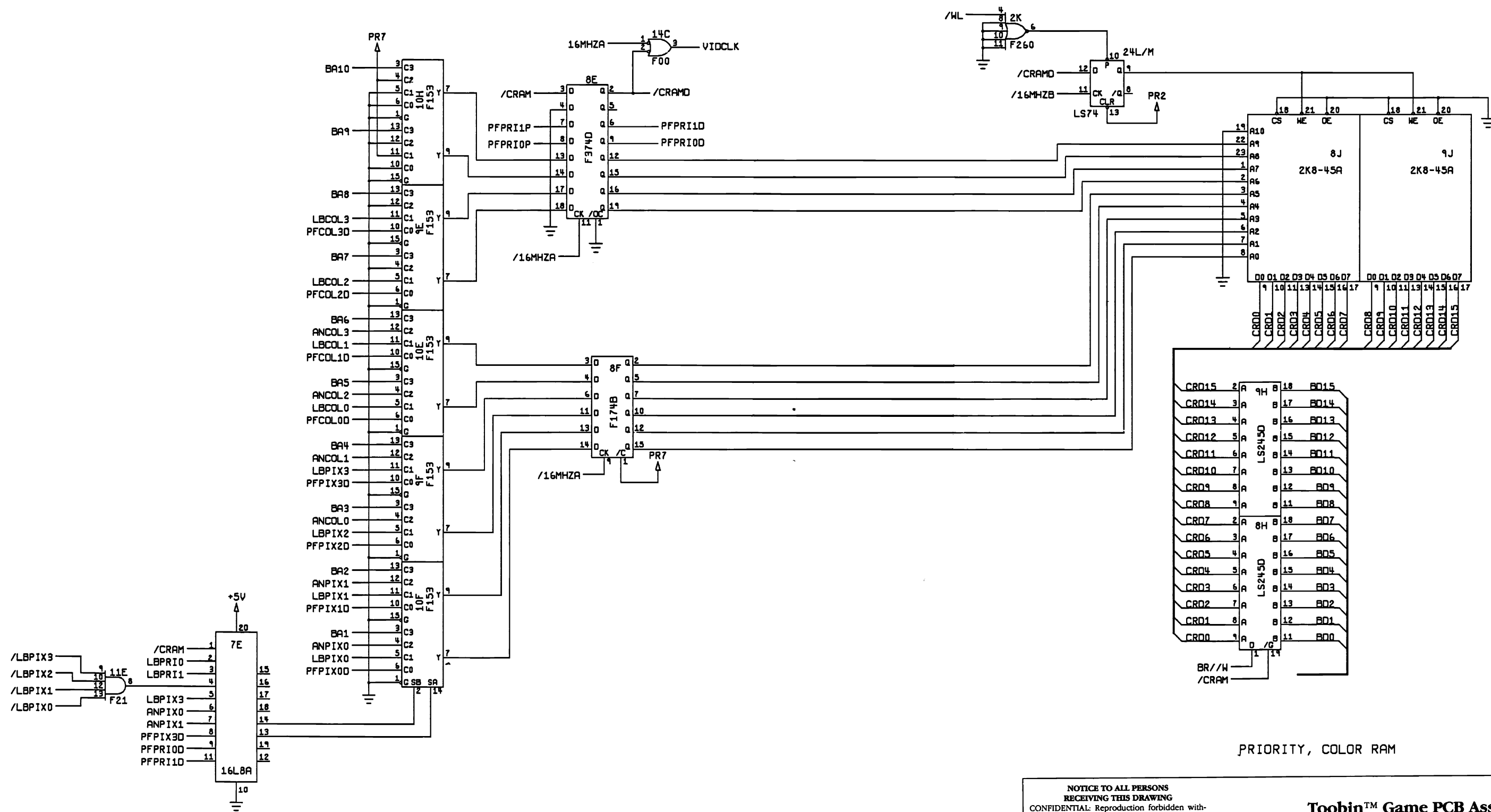

PRIORITY, COLOR RAM

**NOTICE TO ALL PERSONS RECEIVING THIS DRAWING**  
 CONFIDENTIAL: Reproduction forbidden without the specific written permission of Atari Games Corporation, Milpitas, CA. This drawing is only conditionally issued and neither receipt nor possession thereof confers or transfers any right in, or license to use, the subject matter of the drawing or any design or technical information shown thereon, nor any right to reproduce this drawing, or any part thereof. Except for manufacture by vendors of Atari Games Corporation, and for manufacture under the corporation's written license, no right is granted to reproduce this drawing or the subject matter thereof, unless by written agreement with or written permission from the corporation.

**Toobin™ Game PCB Assembly Schematic Diagram**

**ATARI**  
GAMES

© 1988 Atari Games Corporation  
044402-xx A

**SP-320 Sheet 15**  
1st printing



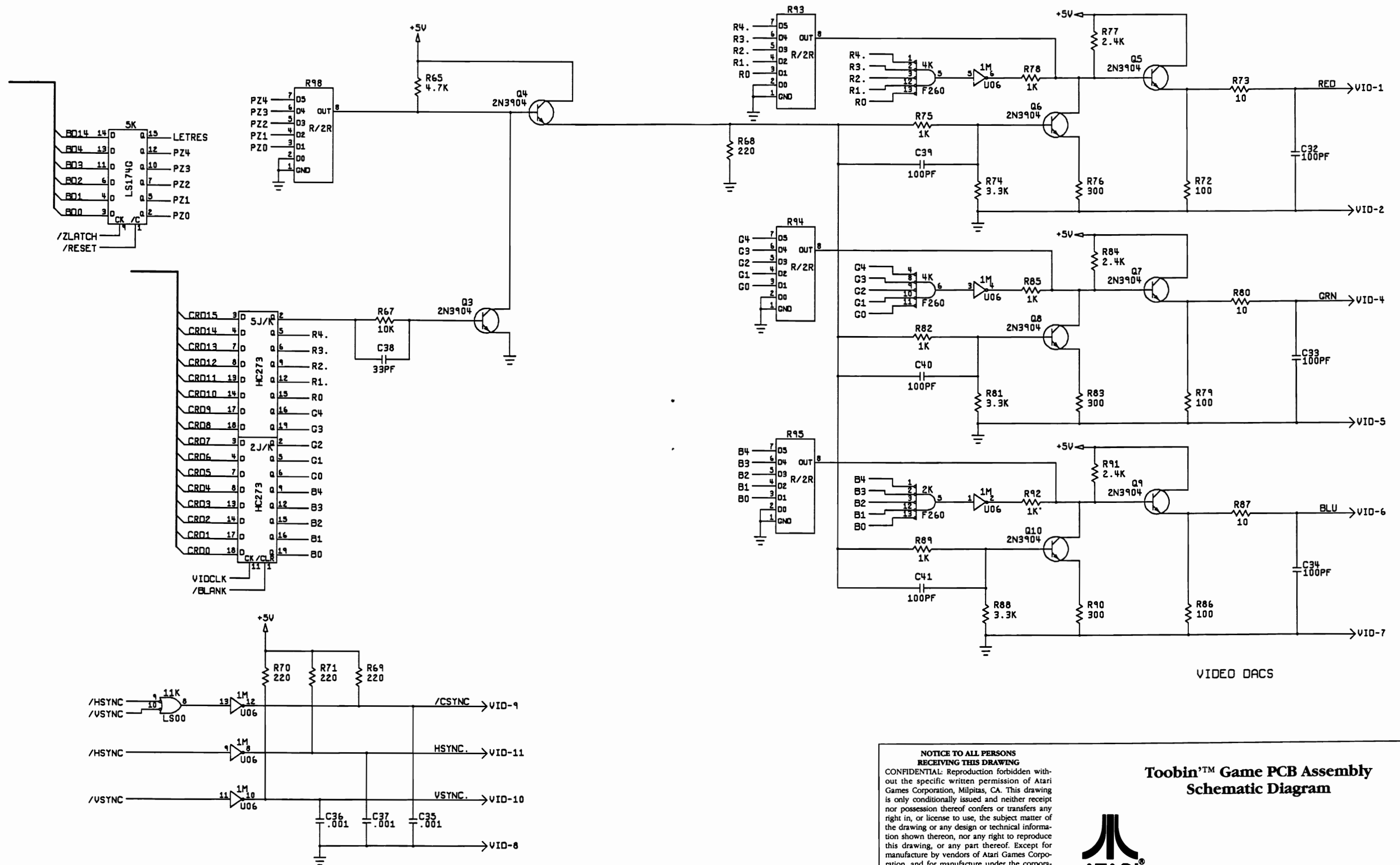

**NOTICE TO ALL PERSONS RECEIVING THIS DRAWING**  
 CONFIDENTIAL: Reproduction forbidden without the specific written permission of Atari Games Corporation, Milpitas, CA. This drawing is only conditionally issued and neither receipt nor possession thereof confers or transfers any right in, or license to use, the subject matter of the drawing or any design or technical information shown thereon, nor any right to reproduce this drawing, or any part thereof. Except for manufacture by vendors of Atari Games Corporation, and for manufacture under the corporation's written license, no right is granted to reproduce this drawing or the subject matter thereof, unless by written agreement with or written permission from the corporation.

**Toobin™ Game PCB Assembly Schematic Diagram**



© 1988 Atari Games Corporation

SP-320 Sheet 16  
1st printing

# Toobin' Memory Map

HEXADECIMAL	ADDRESS						DATA				FUNCTION		
	AAAA	AAAA	AAAA	AA	-----	-----	DDDD	DD	-----	-----			
	2222	1111	1111	11AA	AAAA	AAAA	R/	1111	11DD	DDDD	DDDD		
	3210	9876	5432	1098	7654	3210	W	5432	1098	7654	3210		
000000-07FFFF	0XXX	XAAA	AAAA	AAAA	AAAA	AAAA	R	DDDD	DDDD	DDDD	DDDD	512K BYTES PROGRAM ROM	
C00000-C07FFC	11XX	XX00	0AAA	AAAA	AAAA	AA0X	R/W				DDDD	PLAYFIELD PALETTE	
C00000-C07FFC	11XX	XX00	0AAA	AAAA	AAAA	AA0X	R/W			DDDD		PLAYFIELD PRIORITY	
C00000-C07FFE	11XX	XX00	0AAA	AAAA	AAAA	AA1X	R/W	D				PLAYFIELD VERTICAL FLIP	
C00000-C07FFE	11XX	XX00	0AAA	AAAA	AAAA	AA1X	R/W	D				PLAYFIELD HORIZONTAL FLIP	
C00000-C07FFE	11XX	XX00	0AAA	AAAA	AAAA	AA1X	R/W	DD	DDDD	DDDD	DDDD	PLAYFIELD STAMP CODE	
C08000-C09FFE	11XX	XX00	1XXA	AAAA	AAAA	AAAX	R/W	DDDD	DDDD	DDDD	DDDD	ALPHANUMERICS/MOTION OBJECT RAM	
C08000-C097FE	11XX	XX00	1XXA	AAAA	AAAA	AAAX	R/W	DDDD				ALPHANUMERIC PALETTE	
C08000-C097FE	11XX	XX00	1XXA	AAAA	AAAA	AAAX	R/W		D			ALPHANUMERIC HORIZONTAL FLIP	
C08000-C097FE	11XX	XX00	1XXA	AAAA	AAAA	AAAX	R/W		DDD	DDDD	DDDD	ALPHANUMERIC STAMP CODE	
C09800-C09FF8	11XX	XX00	1XX1	1AAA	AAAA	A00X	R/W	D (1 = ABSOLUTE)				M.O. ABSOLUTE/P.F. RELATIVE POSITION	
C09800-C09FF8	11XX	XX00	1XX1	1AAA	AAAA	A00X	R/W	DDD	DDDD	DD		M.O. VERTICAL POSITION	
C09800-C09FF8	11XX	XX00	1XX1	1AAA	AAAA	A00X	R/W			DD	D	M.O. VERTICAL SIZE	
C09800-C09FF8	11XX	XX00	1XX1	1AAA	AAAA	A00X	R/W				DDD	M.O. HORIZONTAL SIZE	
C09802-C09FFA	11XX	XX00	1XX1	1AAA	AAAA	A01X	R/W	D				M.O. VERTICAL FLIP	
C09802-C09FFA	11XX	XX00	1XX1	1AAA	AAAA	A01X	R/W	D				M.O. HORIZONTAL FLIP	
C09802-C09FFA	11XX	XX00	1XX1	1AAA	AAAA	A01X	R/W	D	DDDD	DDDD	DDDD	M.O. BASE STAMP CODE	
C09804-C09FFC	11XX	XX00	1XX1	1AAA	AAAA	A10X	R/W	DDDD				M.O. PALETTE	
C09804-C09FFC	11XX	XX00	1XX1	1AAA	AAAA	A10X	R/W		DDD	DDDD	D	M.O. LINK POINTER	
C09806-C09FFE	11XX	XX00	1XX1	1AAA	AAAA	A11X	R/W	DDDD	DDDD	DD		M.O. HORIZONTAL POSITION	
C09806-C09FFE	11XX	XX00	1XX1	1AAA	AAAA	A11X	R/W				DDDD	M.O. PRIORITY	
C10000-C101FE	11XX	XX01	0XXX	X00P	PPPC	CCCX	R/W	DDDD	DDDD	DDDD	DDDD	PLAYFIELD COLOR RAM (256 WORDS)	
C10200-C103FE	11XX	XX01	0XXX	X01P	PPPC	CCCX	R/W	DDDD	DDDD	DDDD	DDDD	MOTION OBJECT COLOR RAM (256 WORDS)	
C10400-C1047E	11XX	XX01	0XXX	X100	OPPP	PCCX	R/W	DDDD	DDDD	DDDD	DDDD	ALPHANUMERICS COLOR RAM (64 WORDS)	
						(P = PALETTE, C = COLOR)							
C10000-C107FE	11XX	XX01	0XXX	XAAA	AAAA	AAAX	R/W	DDD	DD			COLOR RAM (ALL) - RED	
C10000-C107FE	11XX	XX01	0XXX	XAAA	AAAA	AAAX	R/W		DD	DDD		COLOR RAM (ALL) - GREEN	
C10000-C107FE	11XX	XX01	0XXX	XAAA	AAAA	AAAX	R/W			D	DDDD	COLOR RAM (ALL) - BLUE	
C10000-C107FE	11XX	XX01	0XXX	XAAA	AAAA	AAAX	R/W	D				COLOR RAM (ALL) - OVERALL INTENSITY DISABLE	
FF8300	1XXX	XX1X	1000	0011	00XX	XXXX	W				D	DDDD	OVERALL COLOR INTENSITY
FF8000	1XXX	XX1X	1000	0000	XXXX	XXXX	W						WATCHDOG CLEAR
FF8100	1XXX	XX1X	1000	0001	XXXX	XXXX	W						COMM. PORT TO SOUND CPU
FF8300	1XXX	XX1X	1000	0011	00XX	XXXX	W			D	DDDD	DDDD	OVERALL COLOR INTENSITY (D4:D0)
F8340	1XXX	XX1X	1000	0011	01XX	XXXX	W		D	DDDD	DDDD		INTERRUPT SCAN LINE
F83C0	1XXX	XX1X	1000	0011	11XX	XXXX	W						IRQ ACKNOWLEDGE
F8400	1XXX	XX1X	1000	0100	XXXX	XXXX	W						SOUND CPU RESET
F8500	1XXX	XX1X	1000	0101	XXXX	XXXX	W						EEPROM UNLOCK STROBE
F8600	1XXX	XX1X	1000	0110	XXXX	XXXX	W	DDDD	DDDD	DD			HSCROLL
F8700	1XXX	XX1X	1000	0111	XXXX	XXXX	W	DDD	DDDD	DD			VSCROLL
F8700	1XXX	XX1X	1000	0111	XXXX	XXXX	W					D	RESTART VSCROLL COUNTER (IF 0 DURING HBLANK)
FF8800	1XXX	XX1X	1000	1XXX	XXXX	XXXX	R	DDDD	DDDD	DDDD	DDDD		SWITCHES
FF9000	1XXX	XX1X	1001	0XXX	XXXX	XXXX	R						INPUTS
FF9000	1XXX	XX1X	1001	0XXX	XXXX	XXXX	R	D					HBLANK (0 = TRUE)
FF9000	1XXX	XX1X	1001	0XXX	XXXX	XXXX	R	D					VBLANK (0 = TRUE)
FF9000	1XXX	XX1X	1001	0XXX	XXXX	XXXX	R	D					SOUND CPU TRANSMIT COMM. LATCH FULL FLAG (0 = FULL)
FF9000	1XXX	XX1X	1001	0XXX	XXXX	XXXX	R	D					SELF-TEST SWITCH (0 = ON)
FF9800	1XXX	XX1X	1001	1XXX	XXXX	XXXX	R			DDDD	DDDD		COMM. PORT FROM SOUND CPU
FFA000-FFAFFE	1XXX	XX1X	101X	AAAA	AAAA	AAA0	R/W			DDDD	DDDD		EEPROM
FFC000-FFFFF	1XXX	XX1X	11AA	AAAA	AAAA	AAAA	R/W	DDDD	DDDD	DDDD	DDDD		8K WORDS RAM (BYTE-ADDRESSABLE)



**NOTICE TO ALL PERSONS RECEIVING THIS DRAWING**  
 CONFIDENTIAL: Reproduction forbidden without the specific written permission of Atari Games Corporation, Milpitas, CA. This drawing is only conditionally issued and neither receipt nor possession thereof confers or transfers any right in, or license to use, the subject matter of the drawing or any design or technical information shown thereon, nor any right to reproduce this drawing, or any part thereof. Except for manufacture by vendors of Atari Games Corporation, and for manufacture under the corporation's written license, no right is granted to reproduce this drawing or the subject matter thereof, unless by written agreement with or written permission from the corporation.

**Toobin'™ Memory Map**

  
 ATARI  
 GAMES

© 1988 Atari Games Corporation  
 SP-320 Sheet 17  
 1st printing

044326-xx A

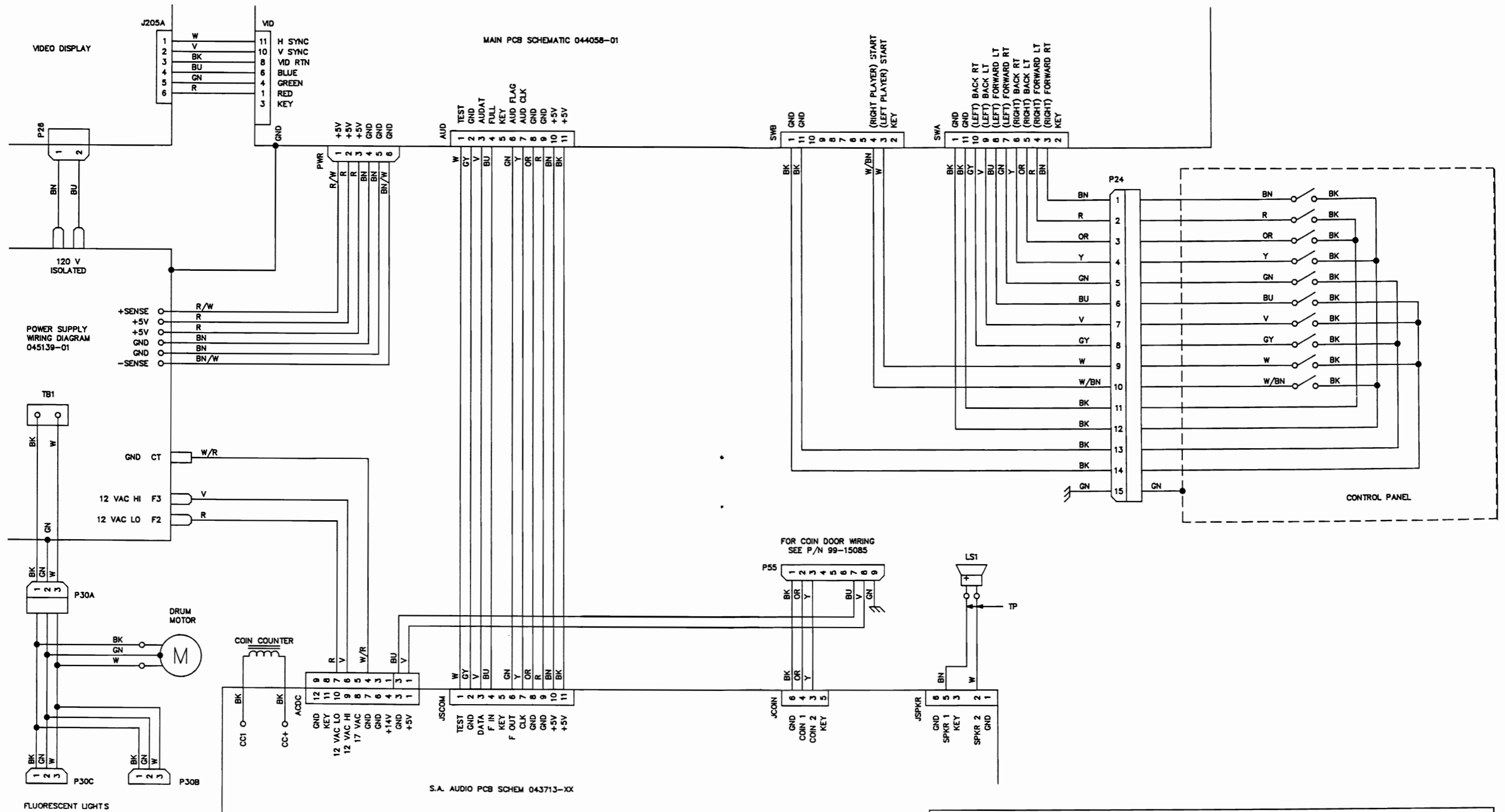

**NOTICE TO ALL PERSONS RECEIVING THIS DRAWING**

CONFIDENTIAL: Reproduction forbidden without the specific written permission of Atari Games Corporation, Milpitas, CA. This drawing is only conditionally issued and neither receipt nor possession thereof confers or transfers any right in, or license to use, the subject matter of the drawing or any design or technical information shown thereon, nor any right to reproduce this drawing, or any part thereof. Except for manufacture by vendors of Atari Games Corporation, and for manufacture under the corporation's written license, no right is granted to reproduce this drawing or the subject matter thereof, unless by written agreement with or written permission from the corporation.

**Toobin™ Main Wiring Diagram**

  
**ATARI**  
 GAMES

© 1988 Atari Games Corporation  
044326-xx A

**SP-320 Sheet 18  
1st printing**

ACDC-11 >-- KEY

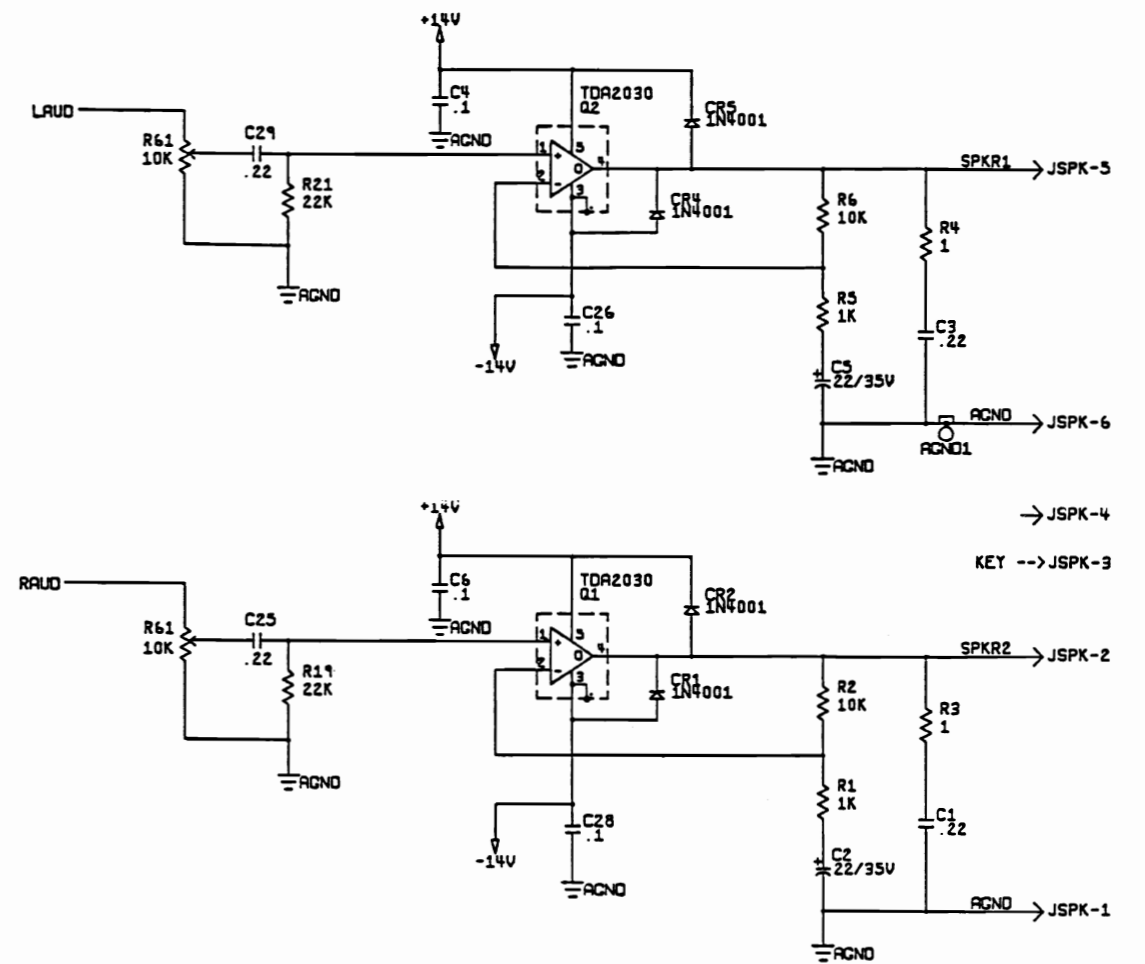
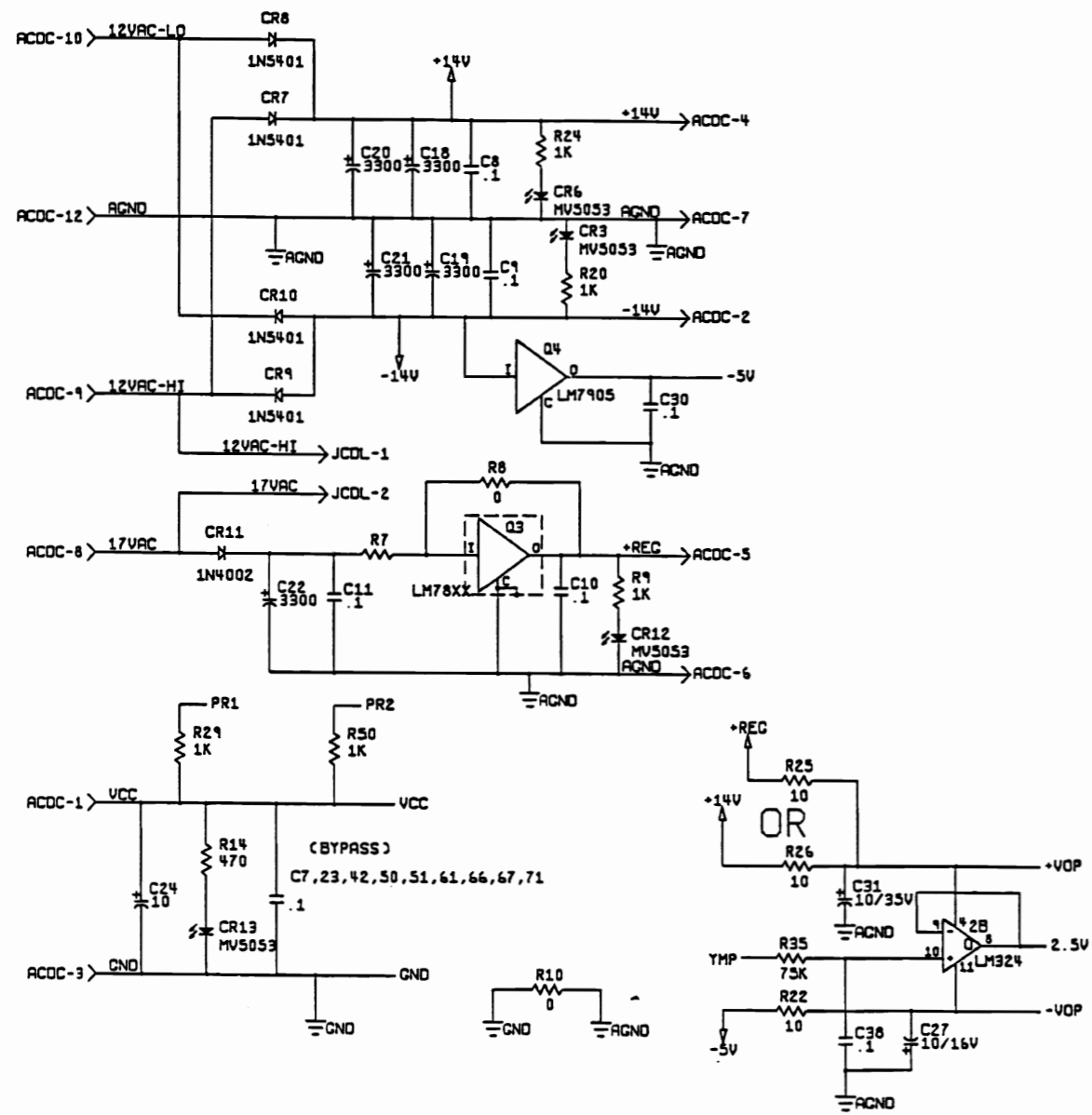

**NOTICE TO ALL PERSONS RECEIVING THIS DRAWING**

CONFIDENTIAL: Reproduction forbidden without the specific written permission of Atari Games Corporation, Milpitas, CA. This drawing is only conditionally issued and neither receipt nor possession thereof confers or transfers any right in, or license to use, the subject matter of the drawing or any design or technical information shown thereon, nor any right to reproduce this drawing, or any part thereof. Except for manufacture by vendors of Atari Games Corporation, and for manufacture under the corporation's written license, no right is granted to reproduce this drawing or the subject matter thereof, unless by written agreement with or written permission from the corporation.

**Stand-Alone Audio PCB Assembly Schematic Diagram, Sheet 1**

  
ATARI  
G A M E S

© 1988 Atari Games Corporation  
049713-xx B

SP-320 Sheet 19  
1st printing

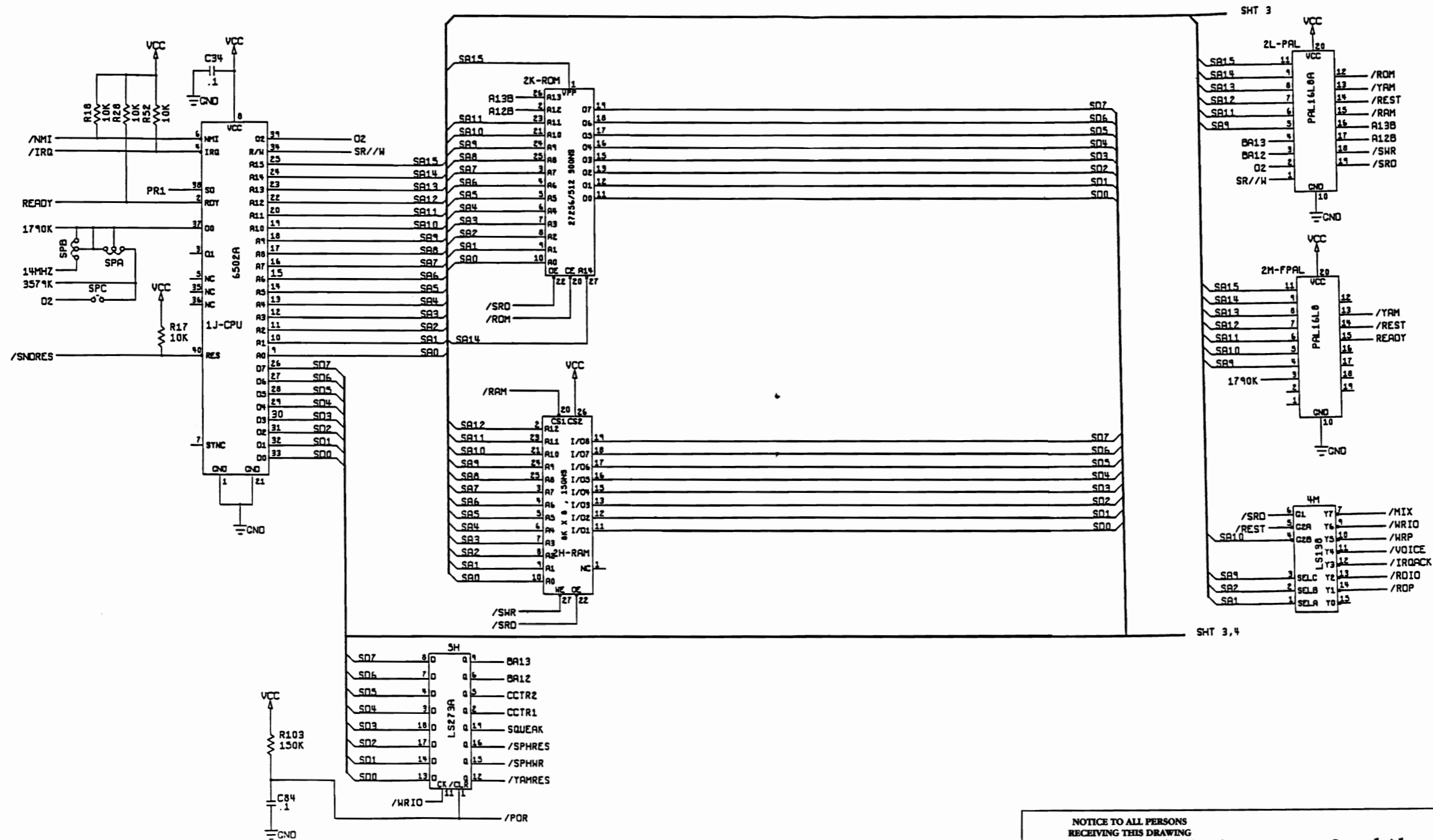

**NOTICE TO ALL PERSONS RECEIVING THIS DRAWING**  
 CONFIDENTIAL: Reproduction forbidden without the specific written permission of Atari Games Corporation, Milpitas, CA. This drawing is only conditionally issued and neither receipt nor possession thereof confers or transfers any right in, or license to use, the subject matter of the drawing or any design or technical information shown thereon, nor any right to reproduce this drawing, or any part thereof. Except for manufacture by vendors of Atari Games Corporation, and for manufacture under the corporation's written license, no right is granted to reproduce this drawing or the subject matter thereof, unless by written agreement with or written permission from the corporation.

**Stand-Alone Audio PCB Assembly Schematic Diagram, Sheet 2**

**ATARI GAMES**

© 1988 Atari Games Corporation  
 SP-320 Sheet 20  
 1st printing  
 043713-xx B

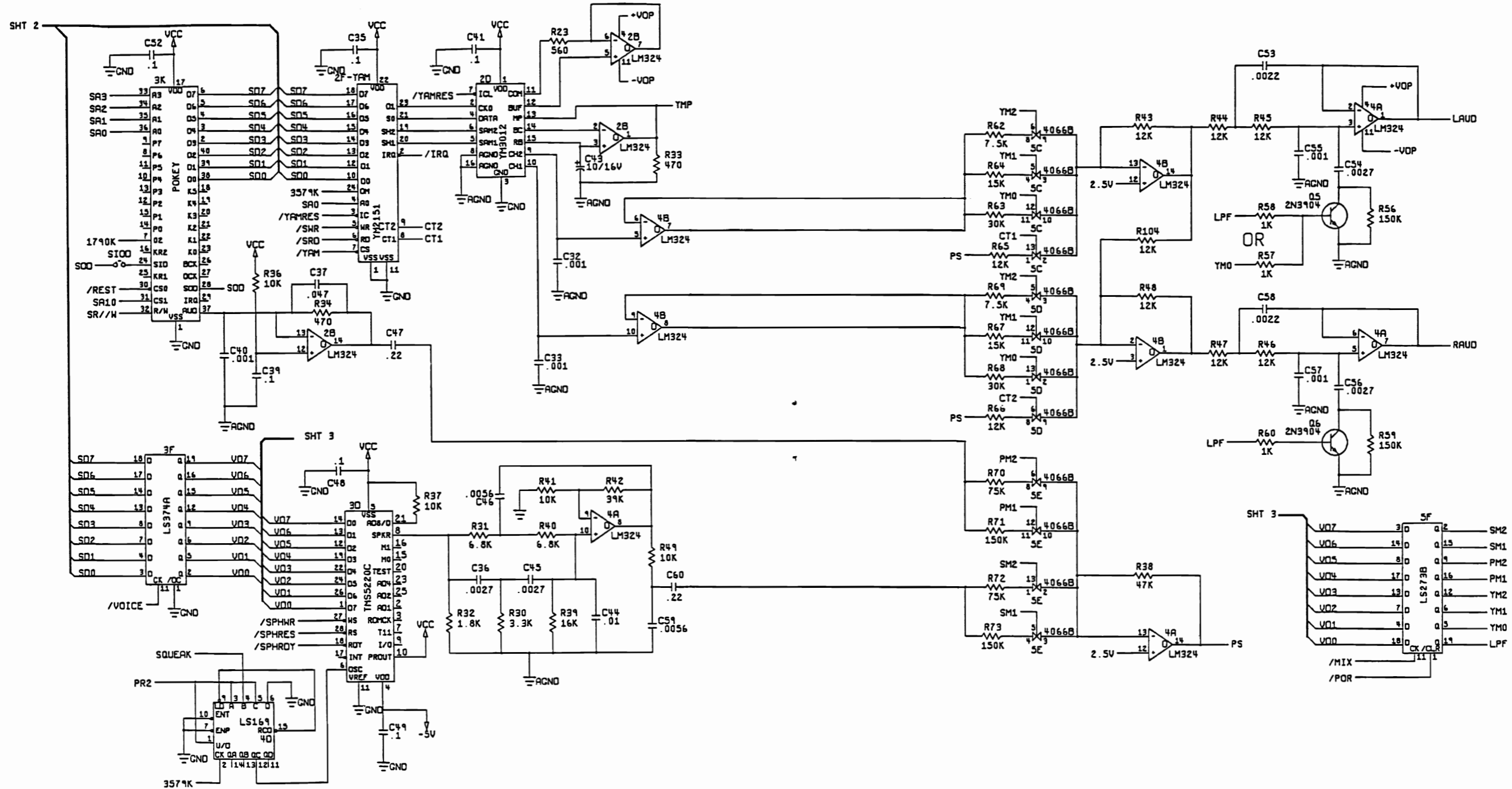

**NOTICE TO ALL PERSONS RECEIVING THIS DRAWING**  
 CONFIDENTIAL: Reproduction forbidden without the specific written permission of Atari Games Corporation, Milpitas, CA. This drawing is only conditionally issued and neither receipt nor possession thereof confers or transfers any right in, or license to use, the subject matter of the drawing or any design or technical information shown thereon, nor any right to reproduce this drawing, or any part thereof. Except for manufacture by vendors of Atari Games Corporation, and for manufacture under the corporation's written license, no right is granted to reproduce this drawing or the subject matter thereof, unless by written agreement with or written permission from the corporation.

**Stand-Alone Audio PCB Assembly Schematic Diagram, Sheet 3**



© 1988 Atari Games Corporation

SP-320 Sheet 21  
1st printing

043713-xx B

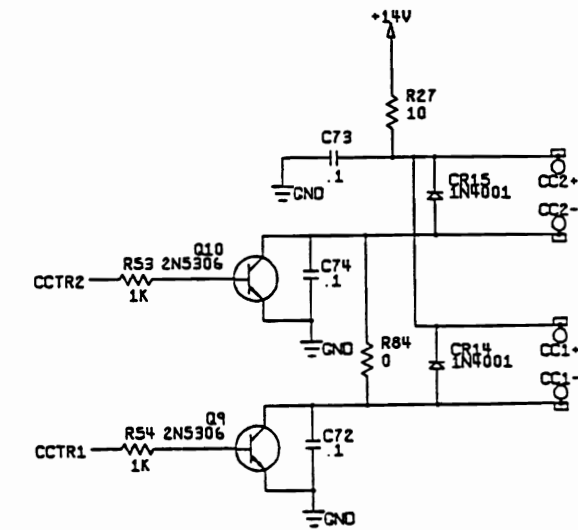
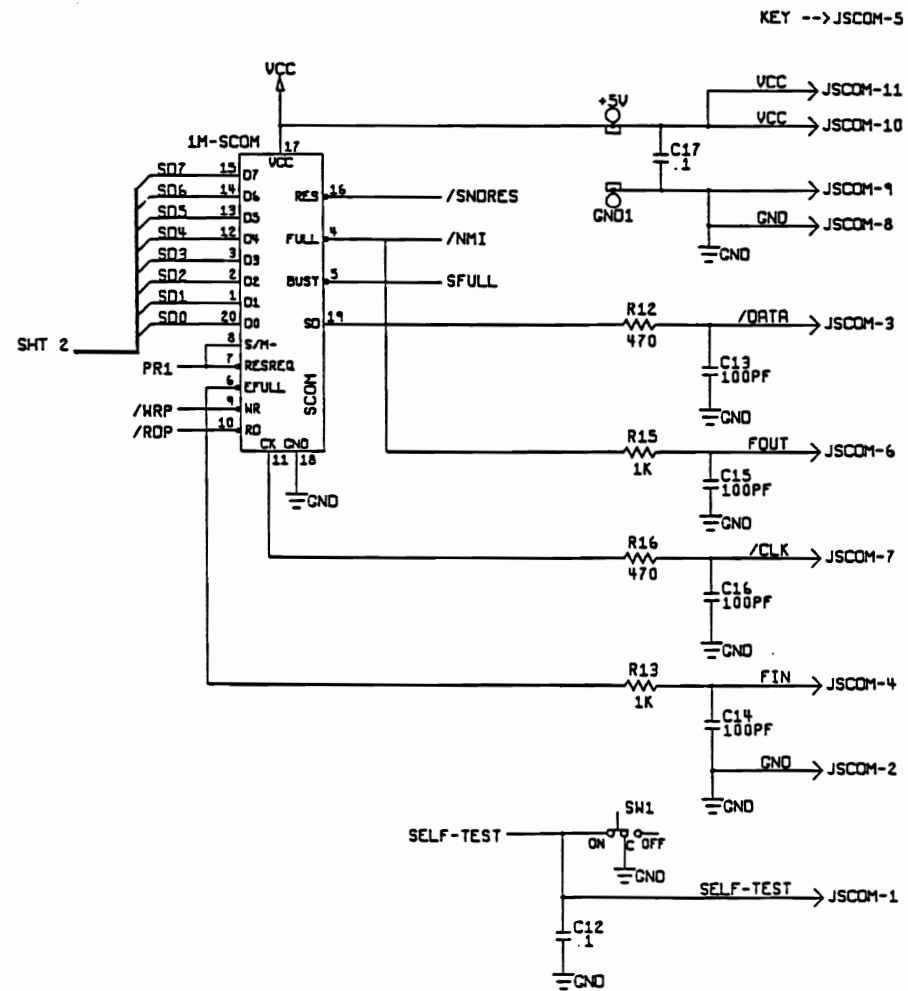
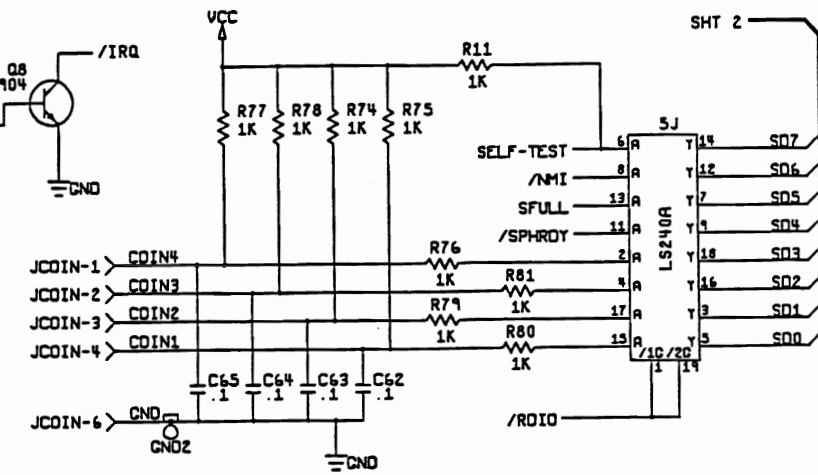
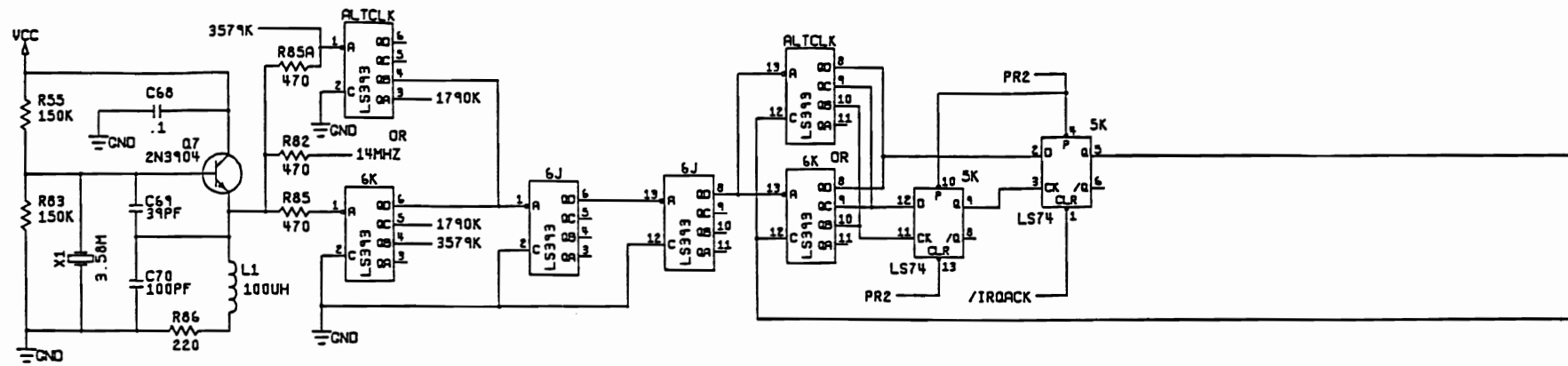

**NOTICE TO ALL PERSONS RECEIVING THIS DRAWING**  
 CONFIDENTIAL: Reproduction forbidden without the specific written permission of Atari Games Corporation, Milpitas, CA. This drawing is only conditionally issued and neither receipt nor possession thereof confers or transfers any right in, or license to use, the subject matter of the drawing or any design or technical information shown thereon, nor any right to reproduce this drawing, or any part thereof. Except for manufacture by vendors of Atari Games Corporation, and for manufacture under the corporation's written license, no right is granted to reproduce this drawing or the subject matter thereof, unless by written agreement with or written permission from the corporation.

**Stand-Alone Audio PCB Assembly Schematic Diagram, Sheet 4**

**ATARI GAMES**

© 1988 Atari Games Corporation

SP-320 Sheet 22  
1st printing

045713-xx B

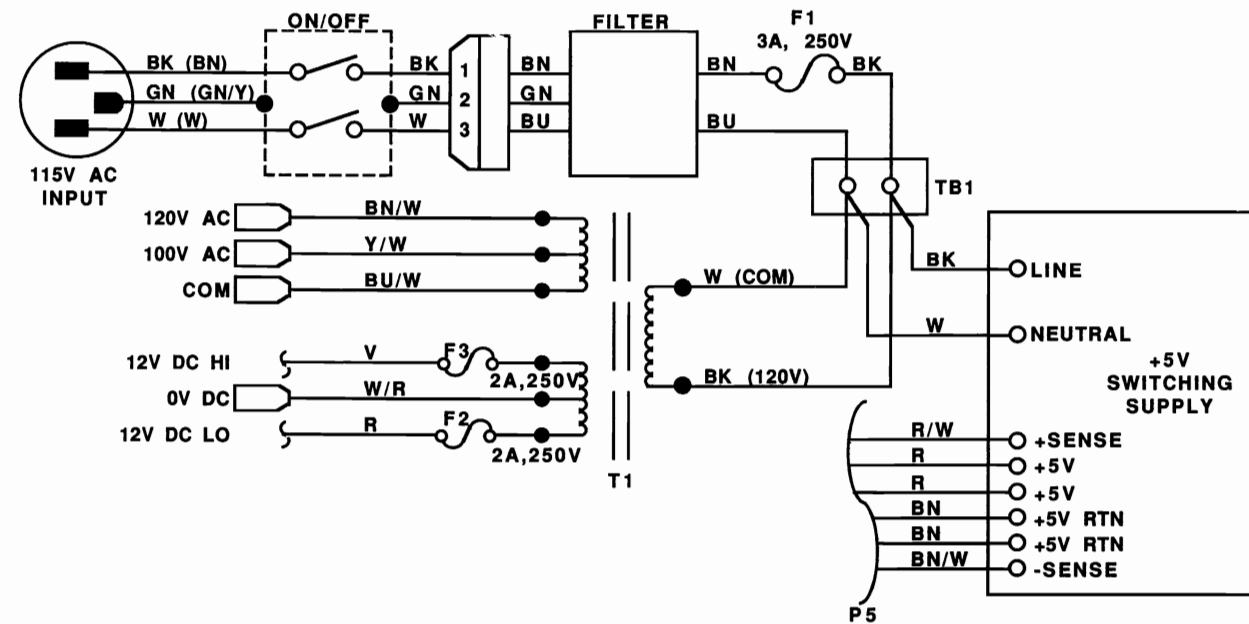

Switching/Linear (SL) Power Supply

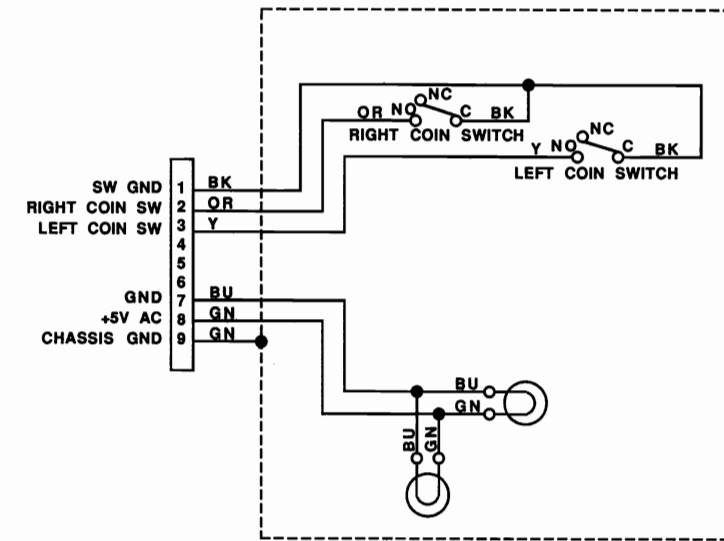

Coin Door Wiring Diagram

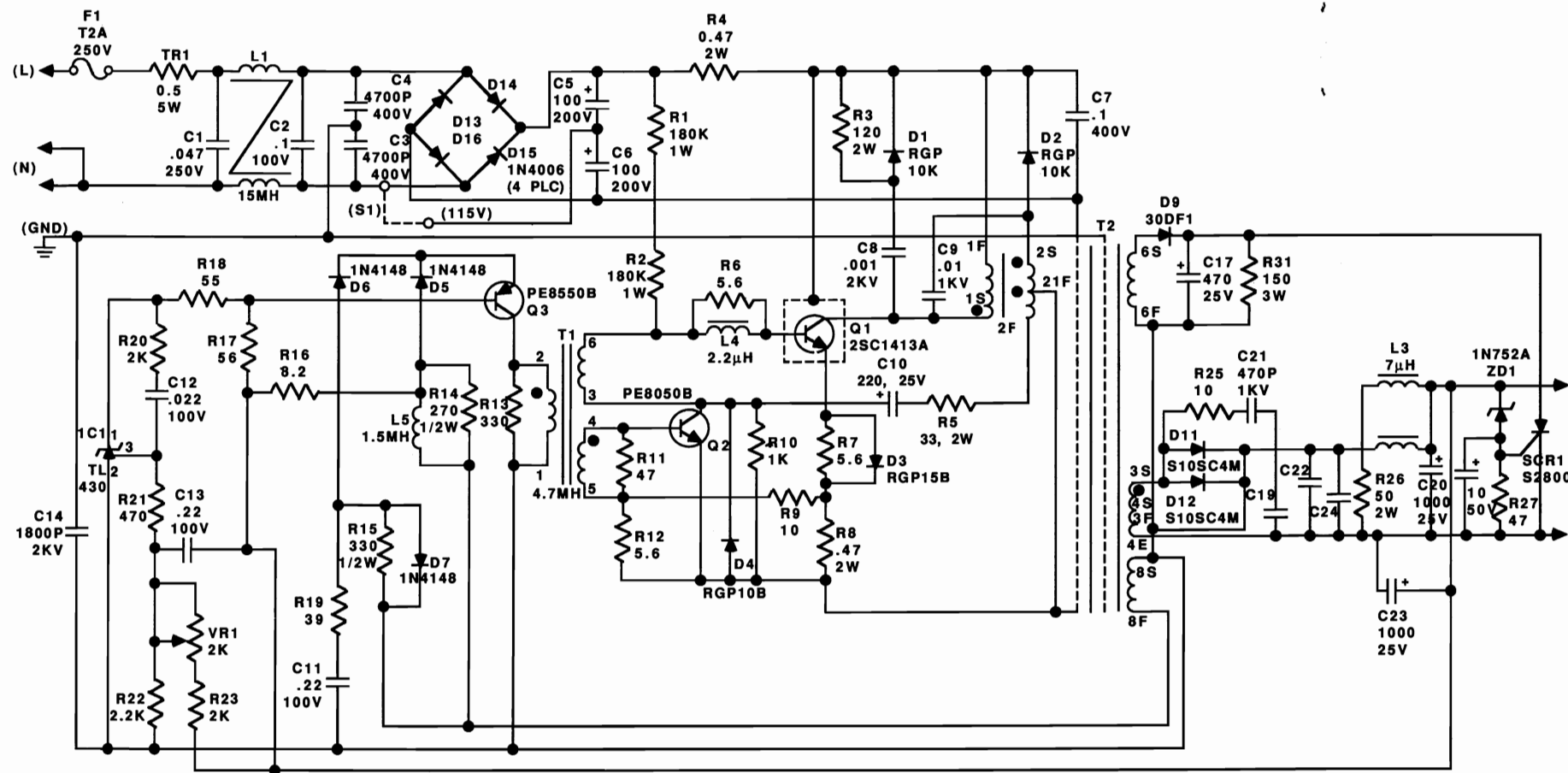

ATARI PART NO: 149003-003 (120V)  
149003-103 (240V)

Hitron 5V 10A Switching Power Supply

**NOTICE TO ALL PERSONS RECEIVING THIS DRAWING**

CONFIDENTIAL: Reproduction forbidden without the specific written permission of Atari Games Corporation, Milpitas, CA. This drawing is only conditionally issued and neither receipt nor possession thereof confers or transfers any right in, or license to use, the subject matter of the drawing or any design or technical information shown thereon, nor any right to reproduce this drawing, or any part thereof. Except for manufacture by vendors of Atari Games Corporation, and for manufacture under the corporation's written license, no right is granted to reproduce this drawing or the subject matter thereof, unless by written agreement with or written permission from the corporation.

**Wiring Diagrams for Switching/Linear (SL) Power Supply, Hitron 5V 10A Switching Power Supply, and Coin Door**

ATARI GAMES

© 1988 Atari Games Corporation  
044871-xx A 149003-003 171027-001

SP-320 Sheet 23  
1st printing