

Installation Instructions

Installing a CDM-12 Player into a CDM-4 Mechanism (Kit #66505908)

These instructions provide installation procedures to help you install a CDM-12 player into an existing CDM-4 mechanism.

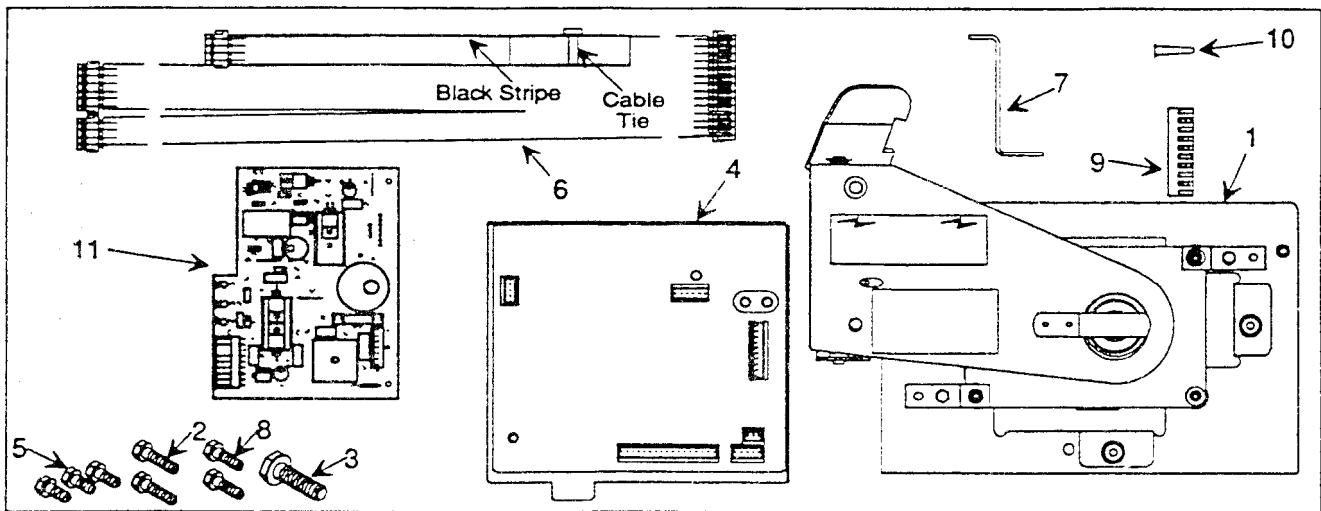

Figure 1. Kit Parts

Required Parts List

Ref.	Description	Part No.	Qty.
	This Instruction Sheet	21999502	1
1	Plate and Player Assembly	61092401	1
2	8-32 x 5/8" Hex WHMS	80743010	2
3	1/4-20 x 1" Sems Hex WHS	80715716	1
4	Mech Control Assembly	61086201	1
5	8-32 x 1/4" Hex WHS	80443004	3
6	Ribbon Harness	40871601	1
7	Reinforcement Bracket	30967602	1
8	8-32 x 3/8" Hex WHMS	80443006	2
9	Connector Housing (10-Position)	70075510	1
10	Keying Plug	70075701	2
11	Power Supply Circuit Board Assembly	61086501	1

TOOLS REQUIRED: A 1/4" and 3/8" nut driver, a 1/16" and 3/16" drift punch, a small hammer, pliers, and a slot head screwdriver (small blade).

INSTALLATION PROCEDURES

NOTE: Turn main power off. Disconnect main harness connections from CD mechanism and check that other restraints are free.

Remove the CD Mechanism from the jukebox.

1. Disconnect all of the Mech and Decoder wire harnesses from the mech assembly on the CDM-3.
2. Loosen the screw located on the right hand side of the mech that retains the Mech and Decoder assembly and remove the assembly.
3. Remove the Cancel switch (leaving the wires attached) and the counters located on the mounting plate. Remove optical switch harness and clip from mounting plate and relocate to optical switch mounting plate.
4. Remove the 1/4-20 screw and the 8-32 screw located near the hold down hinge. Remove the 8-32 screw located on the far right of the mounting plate, near the Mech and Decoder assembly, then remove the mounting plate with player. These mounting points are in the same relative positions as those shown in *Figure 2a*.
5. Before installing the CDM-12 plate and player assembly, loosen hold down brackets (*See Figure 2a*) and remove CDM-12 player. **SPECIAL CARE MUST BE TAKEN TO INSURE THAT NO CONTAMINATION GETS INTO THE PLAYER.** Set the player aside until after the mounting plate and the new mech control assembly has been assembled.
6. With the gripper bow in the magazine (standby position), install new CDM-12 mounting plate assembly. Attach using the 1/4-20 x 1" WHS screw with (2) 8-32 x 5/8" WHMS. The three screws go in the same relative locations as the previous mounting plate (*See Figure 2a*).
7.
 - a. Before installing reinforcement bracket 30967602 (*See Figure 2b*), remove the cable clamp that is on the bottom of the base casting. Relocate the clamp so that the mounting screw hole is toward the back of the mech and install bracket and clamp with (2) 8-32 x 3/8" screws. Secure the top of the reinforcement bracket is with (1) 8-32 x 1/4" screw through the mounting plate assembly.
 - b. Install the previously removed cancel switch and (2) counters to the CDM-12 mounting plate, using nut and screws removed earlier. Locations are indicated on the mounting plate. The counter with the white background digits is the money counter.
 - c. Before installing the new mech control assembly, connect the 14-pin connector of the ribbon harness to P2 of the mech control assembly. Connect the optical switch harness to P1 of the new mech control assembly. *These connections will be difficult to assemble after the mech control assembly is in place.*
 - d. The new mech control assembly has a metal tab extending from the base plate that inserts into the slot of the support frame and the flange of the assembly mounts on top of the CDM-12 mounting plate (*See Figure 2a*) with (2) 8-32 x 1/4" screws. Route the ribbon harness through the cable clamp installed with reinforcement bracket so that the wire tie is to the right-hand side of the clamp.
8. ***Before*** installing the CDM-12 player onto the mounting plate, connect the 4-pin connector with the black stripe to the player circuit board connector facing the front of the mech. Route this portion of the harness through front opening in mounting plate. Connect the remaining connectors, a 4-pin and a 6-pin, through the rear opening of the mounting plate to the player circuit board connectors facing the back of the mech. After replacing the player, adjust the hold down brackets and tighten the mounting screws (*See Figure 2a*).
9. Arrange the mech harness to allow the 17-pin connector room to attach to P7 of new mech control assembly. Cut the restraining tie if necessary.

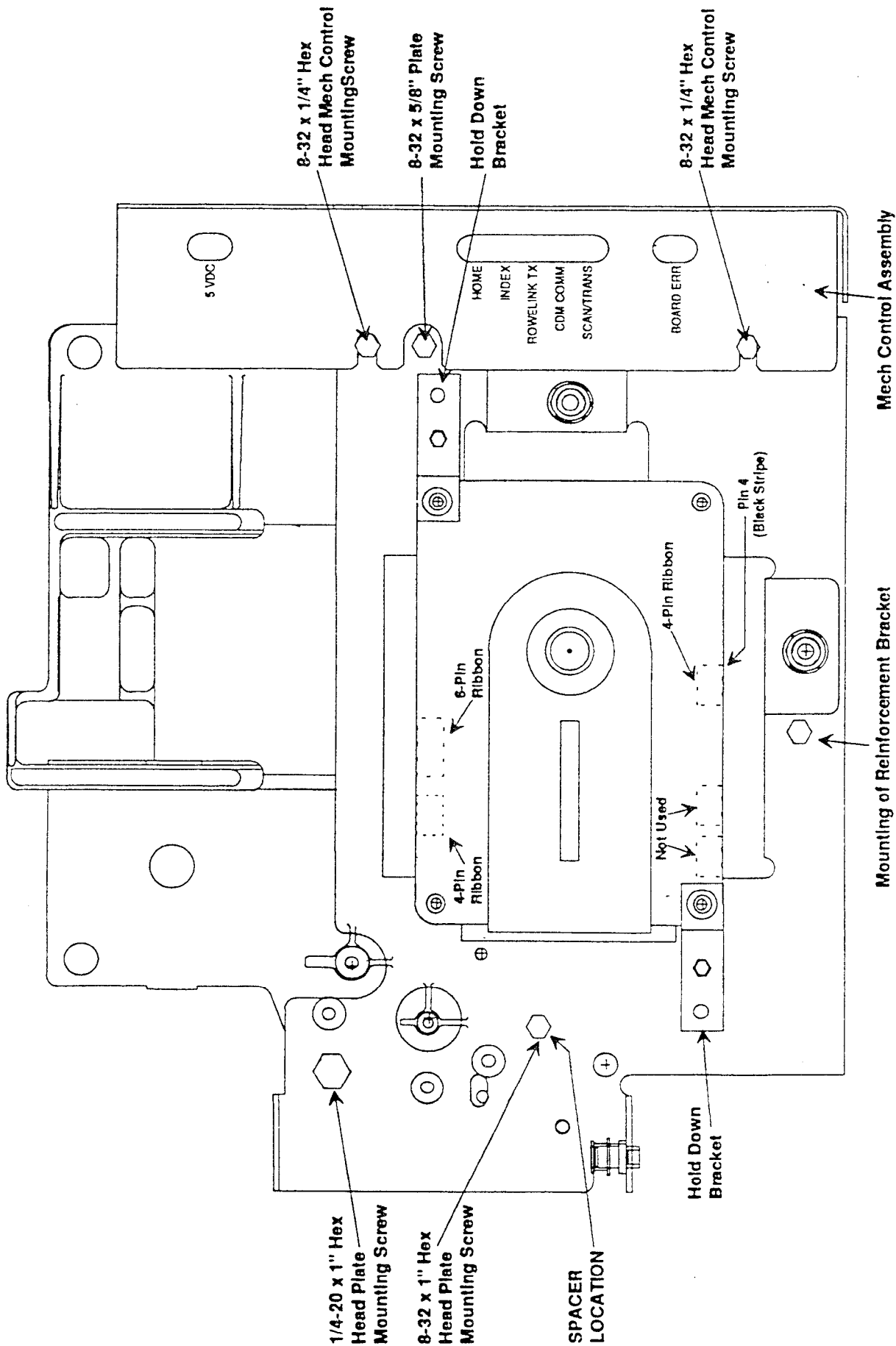

NOTE: Hold-down assembly not shown for clarity

Figure 2a.

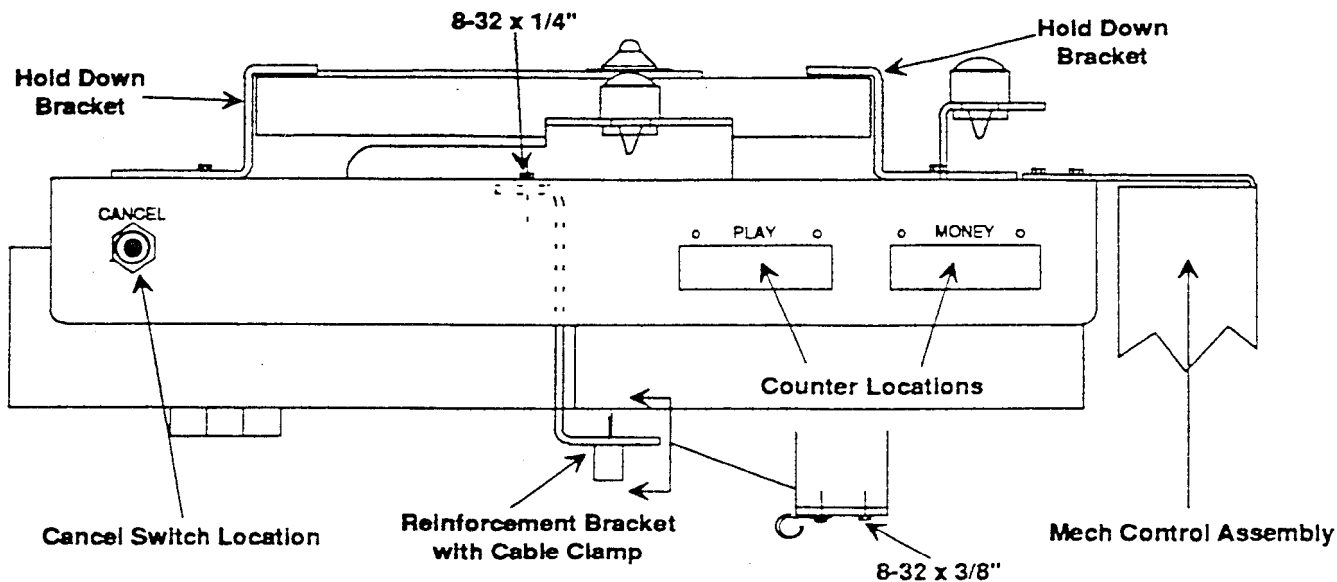

Figure 2b.

10. For locations of harness connectors to the new Mech Control Unit See *Figure 3*.

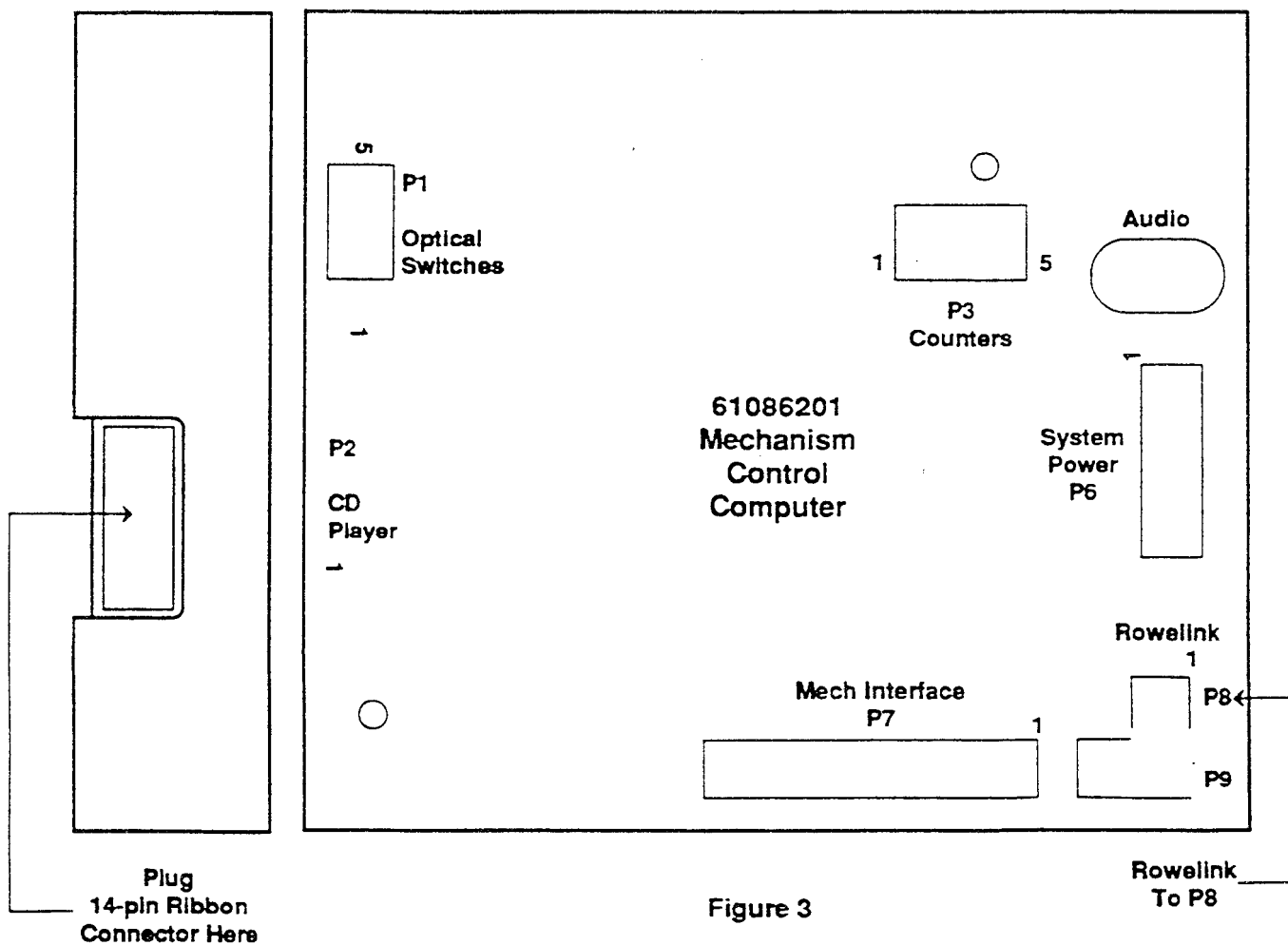

Figure 3

The Main Phonograph harness connections are Rowelink to P8. The audio phono cable plugs and system power connect to P6. The kit contains (1) 10-position connector housing and (2) keying plugs that will mate with P6 system power. To prevent damage to the mech control and the CDM-12 player circuit board assemblies, remove wires from existing connectors P8 and P9 and assemble them into new 10-position housing as shown in *Figure 4*.

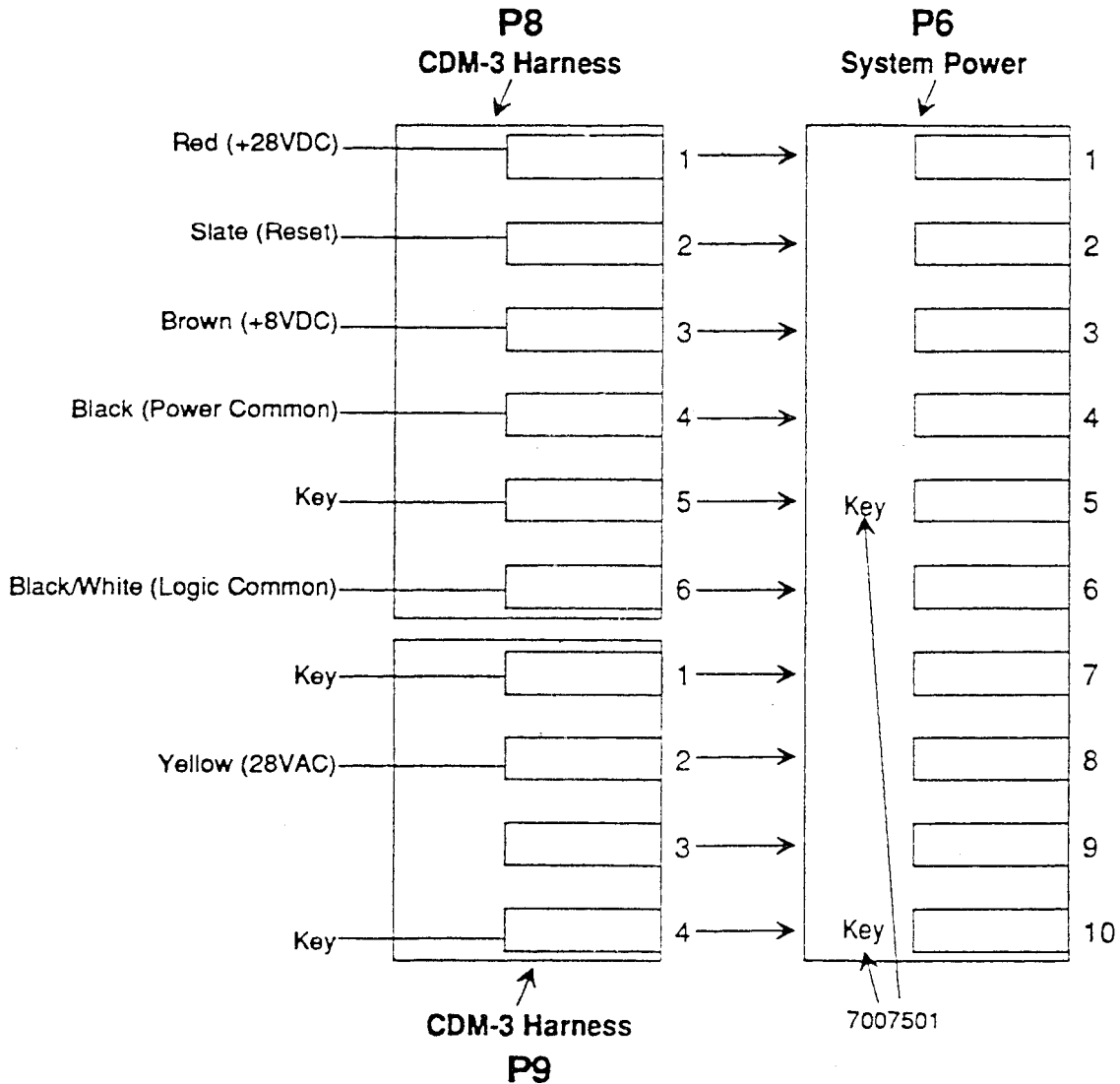

Figure 4

Main Power Supply

- A. Remove main power supply from phonograph.
 - B. Replace the old circuit board assembly with new assembly 61086501. The new board does not use power transistor connections. Dress these wires out of the way.
 - C. Reassembly power supply and install back into phonograph.
24. Reinstall the CD Mechanism in the phonograph.
 25. Test by placing the mech in *SERVICE* mode and rotating magazine with the use of the *CANCEL* button, then test it in *NORMAL* mode by playing a disc.