

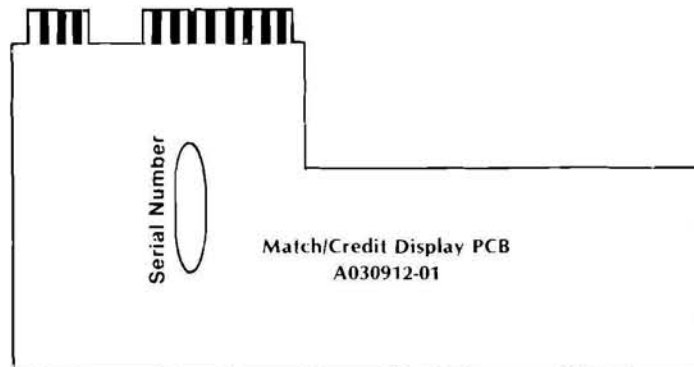

**MIDDLE EARTH**  
Operation, Maintenance and Service Manual  
Complete with Illustrated Parts Catalog

## Location of Serial Numbers

Your game's serial number is stamped on all four printed circuit boards, in the locations shown below. The same number is also stamped on the label located on the rear of the back box. Please mention this number whenever calling your distributor for service.

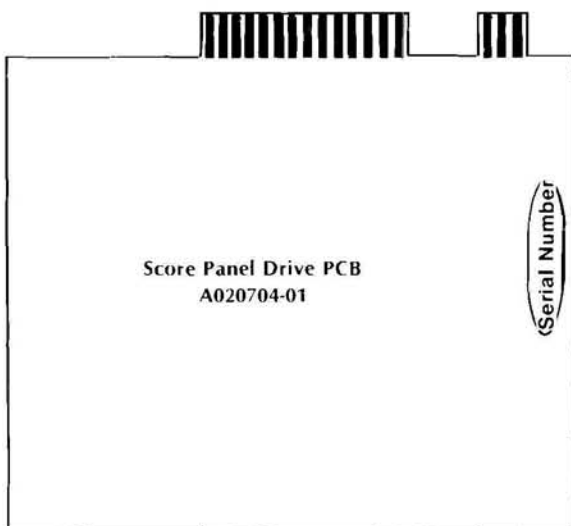
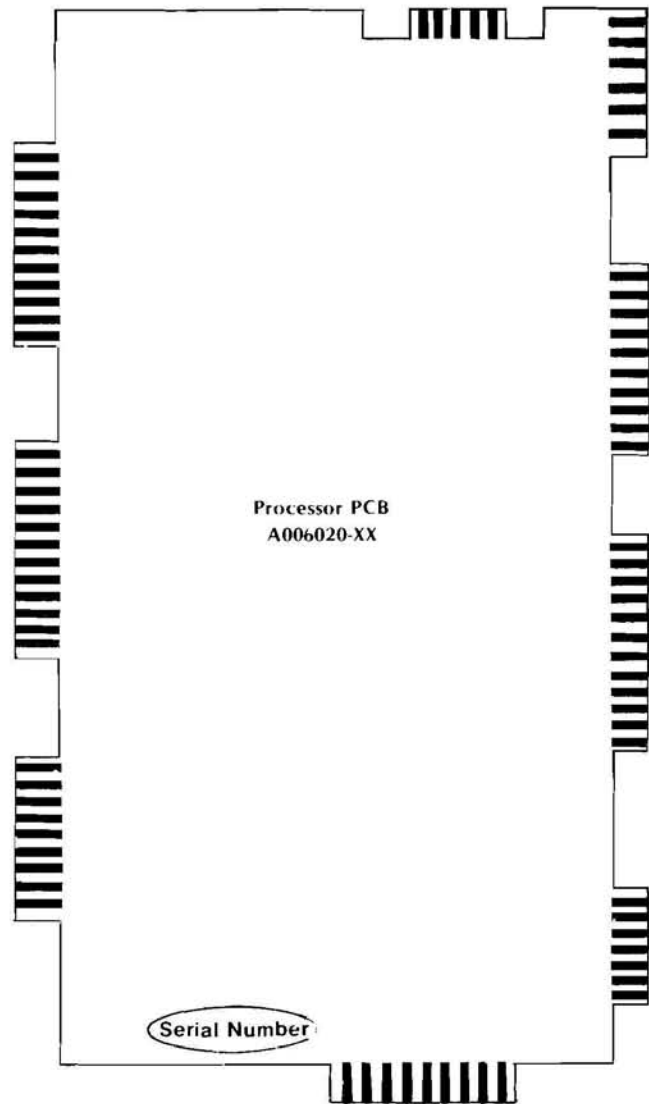
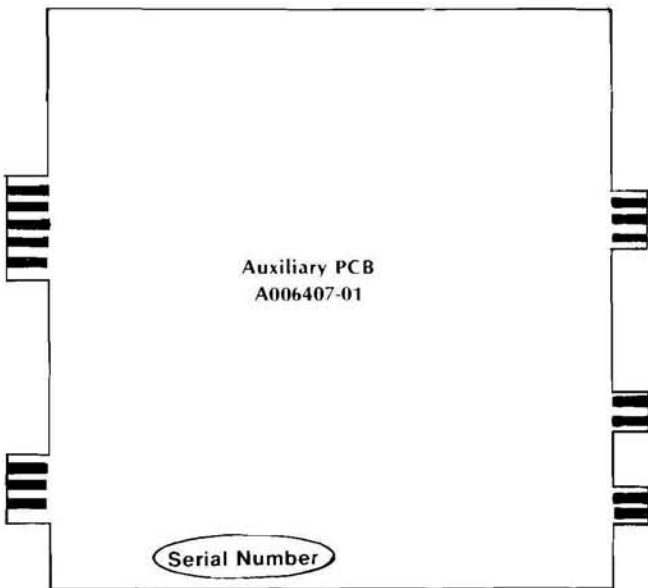

# Middle Earth™

## Operation, Maintenance and Service Manual

Complete with Illustrated Parts Catalog

ATARI INC  
1265 BORREGAS AVENUE  
P.O. BOX 9027  
SUNNYVALE, CALIFORNIA 94086  
408/745-2000 • TELEX 35-7488



ATARI®



Copyright © 1978 by Atari, Inc. All rights reserved

No part of this publication may be reproduced by any mechanical, photographic, or electronic process, or in the form of a phonographic recording, nor may it be stored in a retrieval system, transmitted, or otherwise copied for public or private use, without permission from the publisher.

*For permission request, write:*

**ATARI INC**  
1265 Borregas Avenue  
P.O.Box 9027  
Sunnyvale, California 94086

**4G**

Lithographed in the U.S.A.

# TABLE OF CONTENTS

## 1 LOCATION SETUP

A. INVENTORY OF PARTS IN SHIPPING CARTONS .....	1
B. ASSEMBLY OF GAME .....	2
1. Assembly of Legs and Back Box .....	2
If You Have a Pin Jack .....	2
If You Don't Have a Pin Jack .....	2
2. Attaching Back Box .....	2
3. Final Inspection .....	2
4. Final Assembly .....	2
C. DESCRIPTION OF GAME OPTIONS .....	2
D. SETTING THE OPTIONS .....	2
E. SELF-TEST .....	12
F. VOLUME ADJUSTMENT .....	12

## 2 GAME PLAY

A. ATTRACT MODE .....	13
B. PLAY MODE .....	13
Game Play and Scoring .....	14

## 3 MAINTENANCE AND ADJUSTMENTS

A. CLEANING .....	15
Game Cabinet Exterior .....	15
Playfield .....	16
B. FUSE REPLACEMENT .....	18
C. COIN MECHANISM .....	18
Components on Coin Door .....	18
Access to Coin Mechanisms .....	18
Cleaning of Coin Paths .....	19
Adjustment of Coin Switch Trip Wire .....	19
Mechanical Adjustments on Coin Mechanism .....	20
Lubrication .....	20
General Troubleshooting Hints .....	22
D. GAME CONTROLS AND PLAYFIELD COMPONENTS .....	22
Solenoid Fuses .....	22
Troubleshooting of Playfield Switches Connected in Parallel .....	22
E. GAS-DISCHARGE DISPLAYS .....	22
Preliminary Operational Checks .....	22
Check on +90 and -90 Volts Power Supply Voltage .....	23
Score Panel Removal and Visual Checks .....	23
Replacement of Score Panel .....	24
Removing Display Assembly .....	25
Installing the Display Assembly .....	25
F. LAMP REPLACEMENT .....	26
Playfield Lamps .....	26
Back Box Lamps .....	26
G. ADJUSTMENT OF SPEAKER VOLUME .....	26

# TABLE OF CONTENTS

<b>4 THEORY OF OPERATION</b>	
A. INTRODUCTION	29
B. COMPONENTS OF THE MICROCOMPUTER SYSTEM	31
Microprocessing Unit	31
Program Memory	31
Data Memory	31
Memory Output Latches	31
Clock Generator	31
Tri-State Buffers	32
Control Logic	32
C. CIRCUIT DESCRIPTIONS	32
Solenoid Driver Circuits	32
Lamp Driver Circuits	32
Switch Sensing Circuit	55
Display and Display Data	55
Credit and Match/Ball Display Circuit	59
Score Display Circuit	59
Sound Generator and Speaker Driver Circuits	61

# LIST OF ILLUSTRATIONS

Figure 1	Inventory of Accessories	3
Figure 2	Attaching Legs without Pin Jack	4
Figure 3	Attaching Back Box	5
Figure 4	Final Assembly and Inspection	6
Figure 5	Location of Option Switches	7
Figure 6	Location of Playfield Switches and Solenoids	9
Figure 7	Playfield Rubber Sizes	17
Figure 8	Coin Door Assembly	18
Figure 9	Hinging Open the Magnet Gate Assembly	18
Figure 10	Removal of Coin Mechanism	19
Figure 11	Surfaces to Clean Inside the Coin Mechanism	19
Figure 12	Removal of Plate Covering Rear of Coin Slot	20
Figure 13	Detail View of Coin Switch and Trip Wire	20
Figure 14	Coin Mechanism, Exploded View	21
Figure 15	Close-up View of Lubrication Point	20
Figure 16	Top View of Score and Match/Credit Display Assembly	23

# LIST OF ILLUSTRATIONS

Figure 17	Removal of Score Panel .....	24
Figure 18	Score Panel Terminals .....	24
Figure 19	Line-up of Terminal Pins and Terminal Strips .....	25
Figure 20	Lower Right Corner of Display Assembly .....	26
Figure 21	Location of Technician Adjustment for Speaker Volume .....	27
Figure 22	Functional Block Diagram .....	30
Figure 23	Block Diagram of Microcomputer System .....	33
Figure 24	Middle Earth Wiring Diagram .....	35
Figure 25	Processor PCB Schematic Diagram A006020-11, -14, -15 & -16.....	39
Figure 26	Auxiliary PCB Schematic Diagram 006407-01.....	47
Figure 27	Score Panel Drive PCB Schematic Diagram 020704-01.....	49
Figure 28	Match/Credit PCB Schematic Diagram .....	53
Figure 29	Simplified Diagram of Basic Solenoid Driver Circuit .....	54
Figure 30	Additional Components to be Installed for Each Metering Function Added .....	55
Figure 31	Simplified Diagram of Basic Lamp Driver Circuit .....	56
Figure 32	Simplified Diagram of Switch Sensing Circuit .....	57
Figure 33	Simplified Diagram of Switch Sensing Circuit Waveforms .....	58
Figure 34	Waveforms for Gas Discharge Displays .....	58
Figure 35	Arrangement of Connections to Score Panel .....	60

# LIST OF TABLES

Table 1	Self-Test Procedure .....	10
Table 2	Fuses Located Near Ball Shooter .....	16
Table 3	Fuses Located on Power Supply Assembly .....	16
Table 4	Components Required for Special Metering Functions .....	55

## **5 ILLUSTRATED PARTS CATALOG**

### *SECTION A*

*Final Location Assembly A020163-01 thru -09* ..... Sheet 4

### *SECTION B*

*Cabinet Assembly A006016-04* ..... Sheet 2

### *SECTION C*

#### *Cabinet Sub-Assembly*

*Ball Shooter A004769-01* ..... Sheet 1

*Tilt Board A006728-03 thru -05* ..... Sheet 7

*Flipper Button A004910-01* ..... Sheet 11

*Flipper Button A006071-01* ..... Sheet 16

*Start Button A007010-01* ..... Sheet 18

*Power Supply A006032-09 thru -13* ..... Sheet 24

*Coin Door A009084-01 thru -09* ..... Sheet 31

*Auxilliary PCB A006407-01* ..... Sheet 36

*Processor PCB A006020-11, -14, -15, and -16* ..... Sheet 43

### *SECTION D*

*Back Box Assembly A006986-01 thru -04* ..... Sheet 1

### *SECTION F*

*Playfield Assembly A020164-01* ..... Sheet 4

### *SECTION G*

#### *Playfield Sub-Assembly*

*Kick-Out Hole A006067-01* ..... Sheet 4

*Slingshot Kicker A006074-01* ..... Sheet 12

*Thumper Bumper A006049-01* ..... Sheet 26

*Linear Flipper A020400-01 and -02* ..... Sheet 33

*Drop Target A020275-01* ..... Sheet 44

*Spinning Target A020106-02* ..... Sheet 46

*Switch and Bracket A020375-01* ..... Sheet 67

*Kick-Out Ball Hole Switch A007877-01* ..... Sheet 68

*Ball Gate A020314-01* ..... Sheet 78

*Rollover Switch A030983-01* ..... Sheet 88

*Score Display A020732-01* ..... Sheet 96C

*Score Display Drive PCB A020704-01* ..... Sheet 96D

*Match/Credit PCB A030912-01* ..... Sheet 96E

*Ball Return Ramp A007833-01* ..... Sheet 97



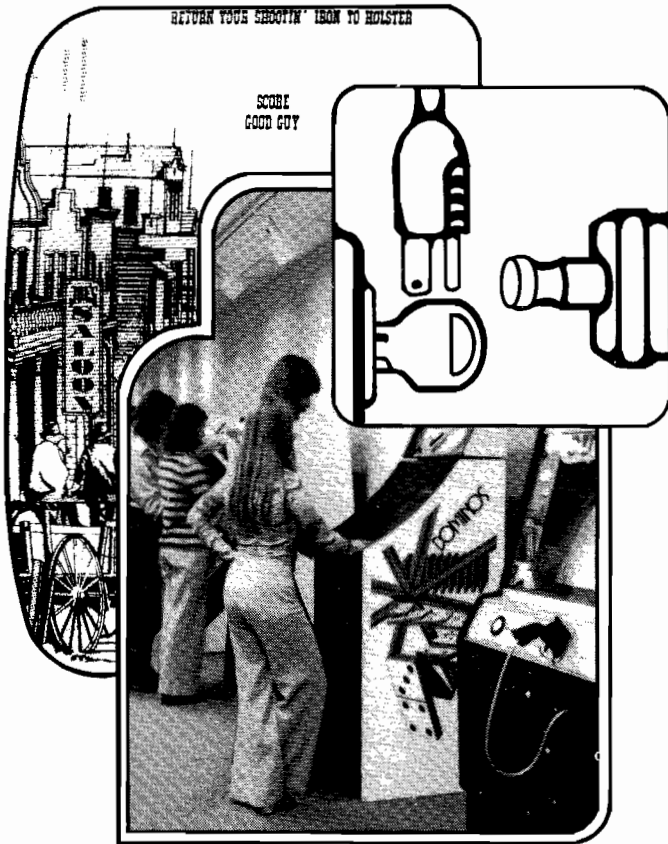

## LOCATION SETUP

### NOTE

If reading through this manual does not lead to solving your specific problem, you can reach Atari's Customer Service Department by telephone (open Monday through Friday, 7:30 a.m. to 4:00 p.m. Pacific Time):

From inside California, Alaska or Hawaii:  
(408) 984-1900

From the remaining 47 states, toll-free:  
(800) 538-6892

### A. INVENTORY OF PARTS IN SHIPPING CARTONS

As you already know, Atari's Middle Earth™ came to you packaged in one big carton containing 1) game cabinet 2) back box carton, and 3) accessories

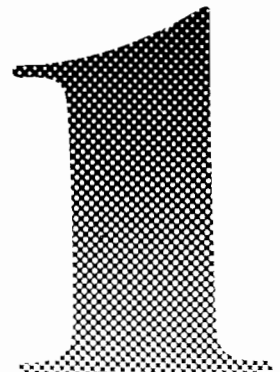

carton. Contained in the accessories box were the game cabinet legs, cash box, and this manual. Keys to the coin door are taped to the top back of the game cabinet. Keys to the back box are taped to the bottom of the back box.

**WARNING**

Do not apply power to game until you have inspected inside of cabinet.

## **B. ASSEMBLY OF GAME**

### **1. Assembly of Legs and Back Box**

First, screw leg levelers (from cash box) into the bottom of each leg. Screw the leg leveler locking nuts onto the leg levelers.

*If you have a Pin Jack*—Place cabinet onto pin jack and raise cabinet at least 2 feet from floor. Then attach all four legs with eight acorn-head bolts.

*If you don't have a Pin Jack*—Refer to Figure 2 and follow the instructions.

### **2. Attach Back Box**

**CAUTION**

Back Box carton is labeled "This side up ↑." Set the Back Box carton as labeled before removing the Back Box from the carton. This will prevent the Back Box glass from falling out and breaking.

Remove the Back Box and Back Box Key Envelope from the Back Box carton and attach the Back Box to the pin cabinet as instructed in Figure 3.

### **3. Final Inspection**

Refer to Figure 4 and follow the instructions.

### **4. Final Assembly**

**NOTE**

The tilt bob is made of a soft material, carbon: don't overtighten.

1. Install the tilt bob (from cash box) onto the pendulum wire at the right front side of the pin cabinet. Tighten the thumb screw lightly and leave it pointing toward the coin door. This way it will be accessible from the coin door for fine tuning after the playfield is lowered.

2. Place the game ball (from cash box) onto the playfield.
3. Choose the proper instruction cards (from cash box) and attach to the lower arch panel butyrate as illustrated in Figure 5.
4. Install the cash box.
5. Lower the playfield and install the playfield glass (for help, refer to Figure 4).
6. Level the playfield for a 3° slope from the rear to the front of the playfield.
7. Insert the power plug into a 115 VAC power source.

## **C. DESCRIPTIONS OF GAME OPTIONS**

Several options are available for structuring Middle Earth™ for maximum returns at your location. The following is a list of these options:

1. Sixteen coin/credit settings
2. Four maximum credit levels
3. Single or double bonus advance during last ball
4. Active or inactive match feature
5. Four different awards for "special" (10,000 points, 20,000 points, replay, or extra ball)
6. Three- or five-ball game
7. Extra ball or 10,000 points for completing extra ball sequence
8. Add-a-ball, replay, or neither for obtaining replay level
9. Standard or multiplied scoring

## **D. SETTING THE OPTIONS**

**WARNING**

Power should never be on while setting the options. Dangerous voltages are present inside the game cabinet.

All the options are selectable by merely flipping a switch. Refer to Self-Test Procedure in Table 1. Table

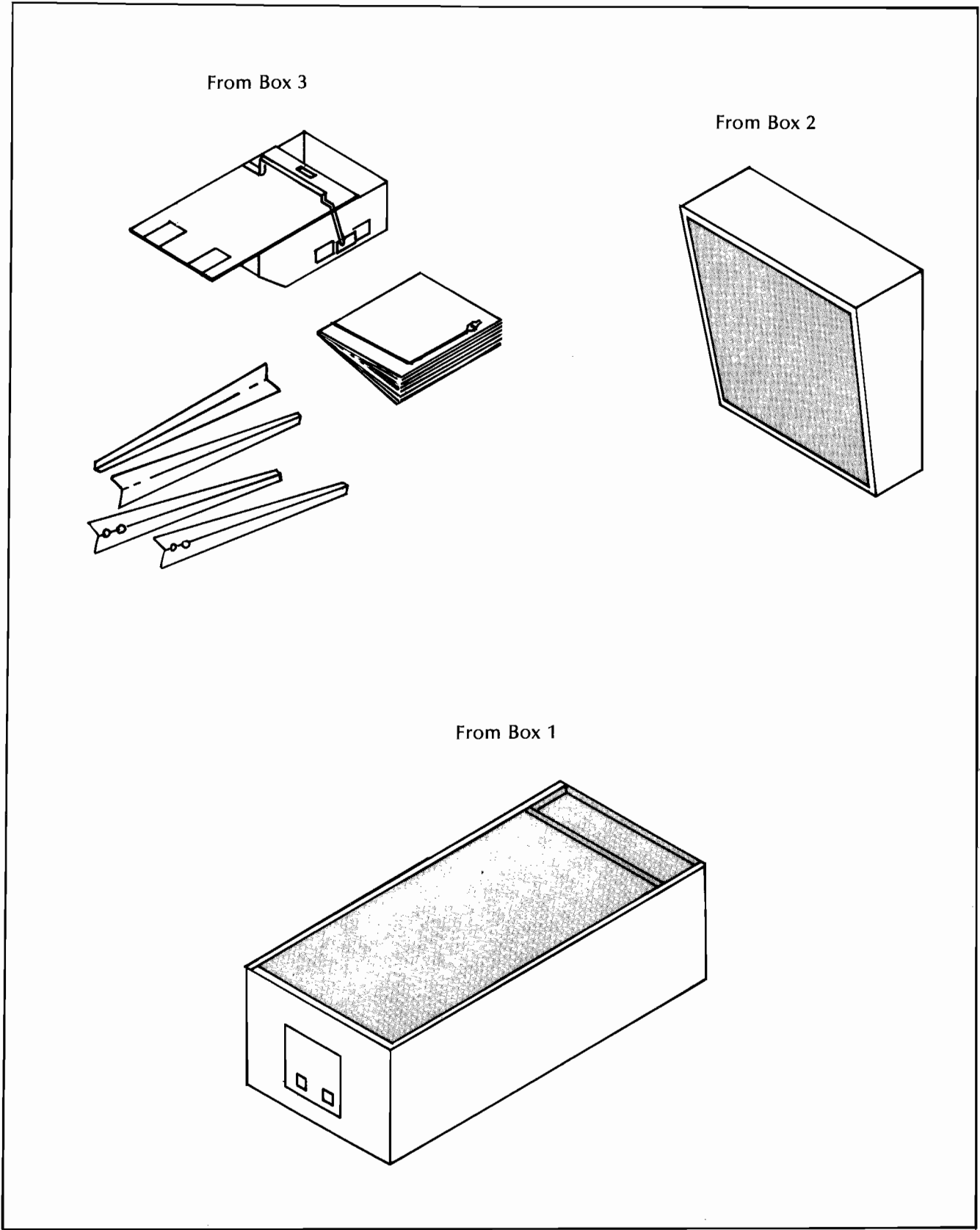

Figure 1 Inventory of Accessories

1. Tilt cabinet and set it on its back on a padded surface (shipping carton works great).

2. Attach two legs to the front of cabinet with four acorn-head bolts.

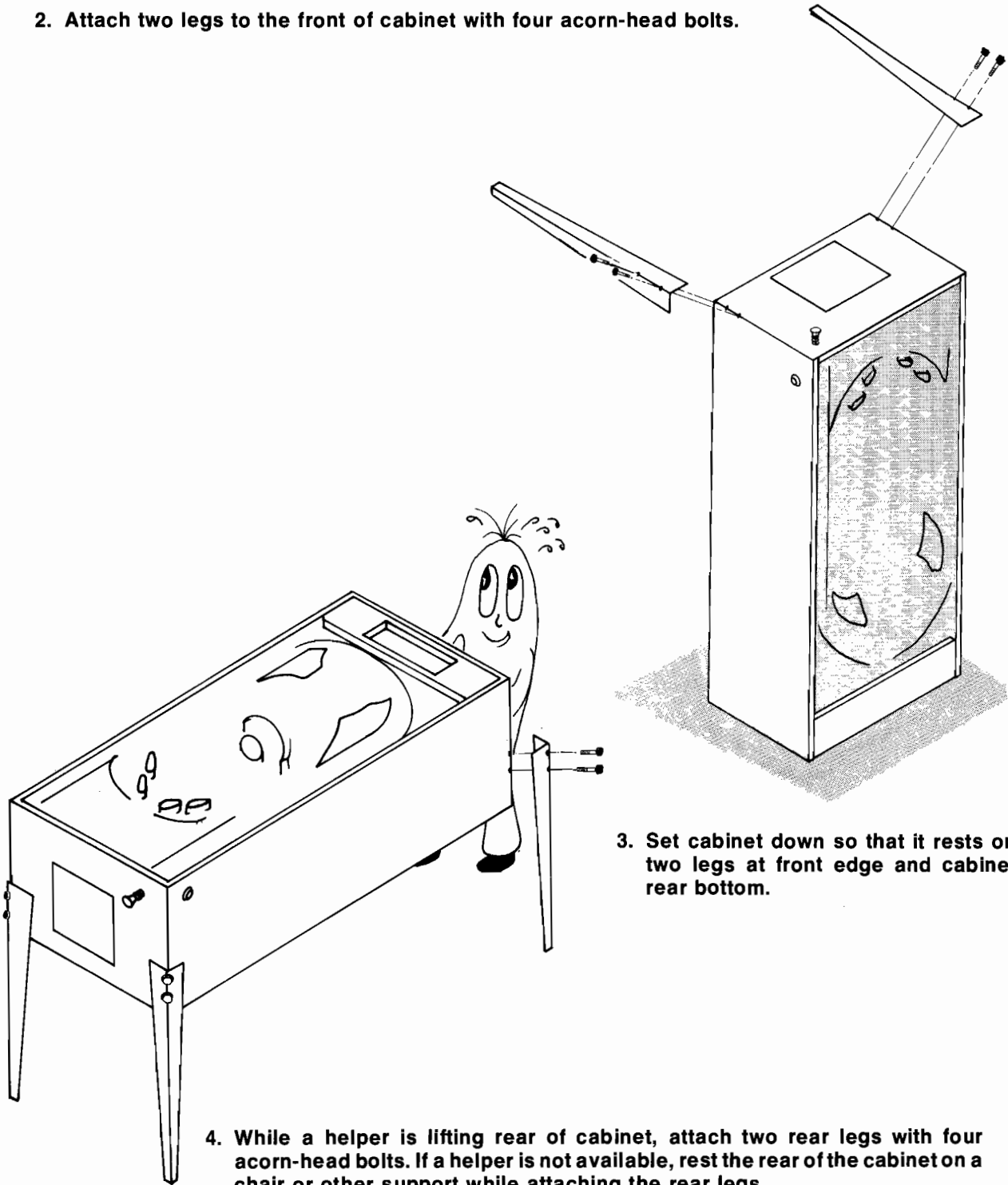
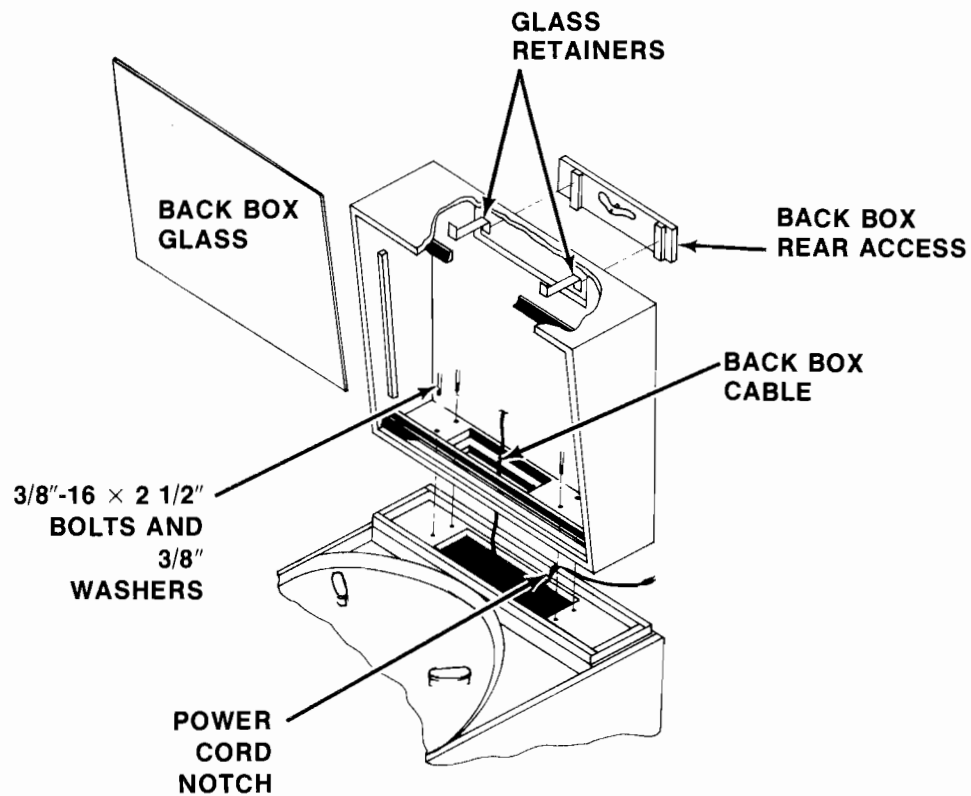
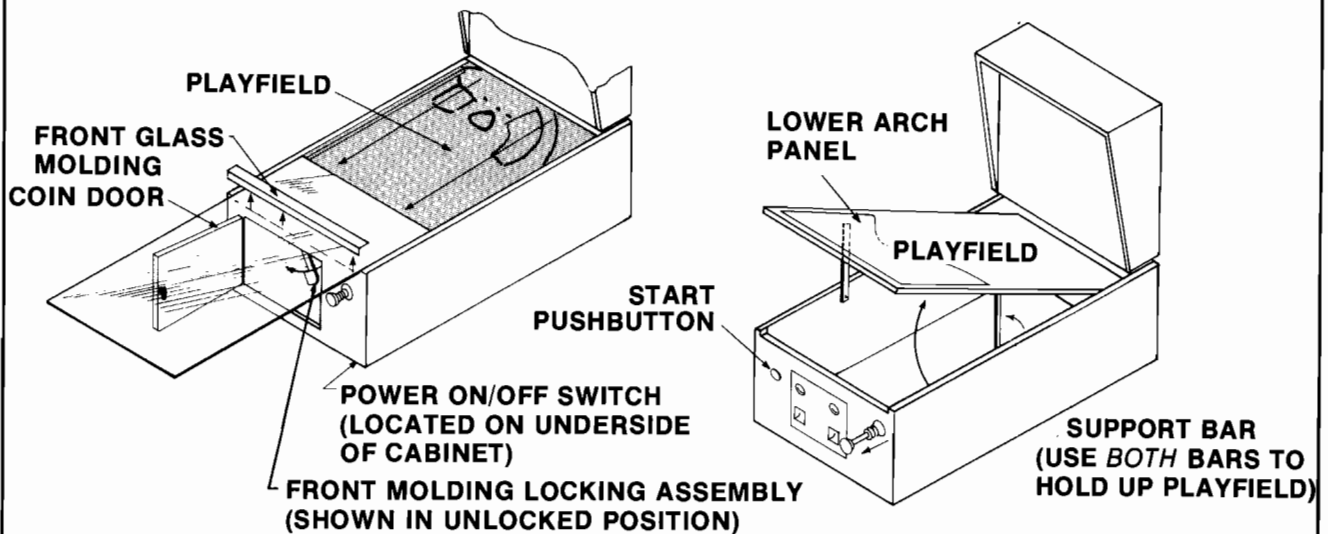

Figure 2 Attaching Legs without Pin Jack



1. Reach into hole at the back of the cabinet and pull out the power cord. Insert the cord into the notch at the back of the cabinet.
2. Remove the key envelope from the top rear of the cabinet.
3. Unlock and remove Back Box rear access.
4. Pull (about 1/2 inch) on both glass retainers.
5. Push up on glass and lift up and out of Back Box.
6. Attach Back Box to the cabinet with four 3/8"-16 × 2-1/2" bolts and four 3/8" flat washers. (Place power cord into the power cord notch.)
7. Unwind Back Box cable and feed down through hole in Back Box and into the cabinet. Plug the cable connector into the two pin connector receptacle on the lower left front of the Power Supply.
8. Snug all lamps, then reinstall Back Box glass.
9. Install and lock Back Box rear access.

Figure 3 Attaching Back Box



1. Unlock and open the coin door.
2. Move the playfield Front Molding Locking Assembly to the left and remove the playfield Front Glass Molding.
3. Remove mounting screws from the lower Arch Panel. Pull out and discard the foam packing from above the Score Display. Check that the edge pins of the Score Display are aligned with the pins of the interfacing connector. Remount the Lower Arch Panel.
4. Lift the front of the playfield and rest it on *both* support bars.
5. Locate two loosely tied large nylon cable ties, one mounted on each side of the cabinet, that secure the connectors during shipping. Cut these cable ties.
6. Loosen J21
7. Temporarily lift the black plastic cover from above the Processor PCB by squeezing the plastic clips that stick through the black cover.
8. Thoroughly inspect the game as follows:

#### Cabinet Inspection

1. Check that all connectors are properly seated.
2. Check that all fuses are properly seated.
3. Check that there are no disconnected wires.
4. Check entire cabinet for loose or foreign objects that may cause short circuiting.
5. Check that the contacts of the vertical slam switch, located on the bottom of the cabinet, and the coin door slam switch contacts are both open.
6. Check to ensure that the black plastic cover over the Processor PCB is attached.

#### Playfield Inspection

Check that all harness wires on the underside of the playfield are out of the way of all moving parts and free from being pinched when the playfield is lowered.

Figure 4 Final Assembly and Inspection

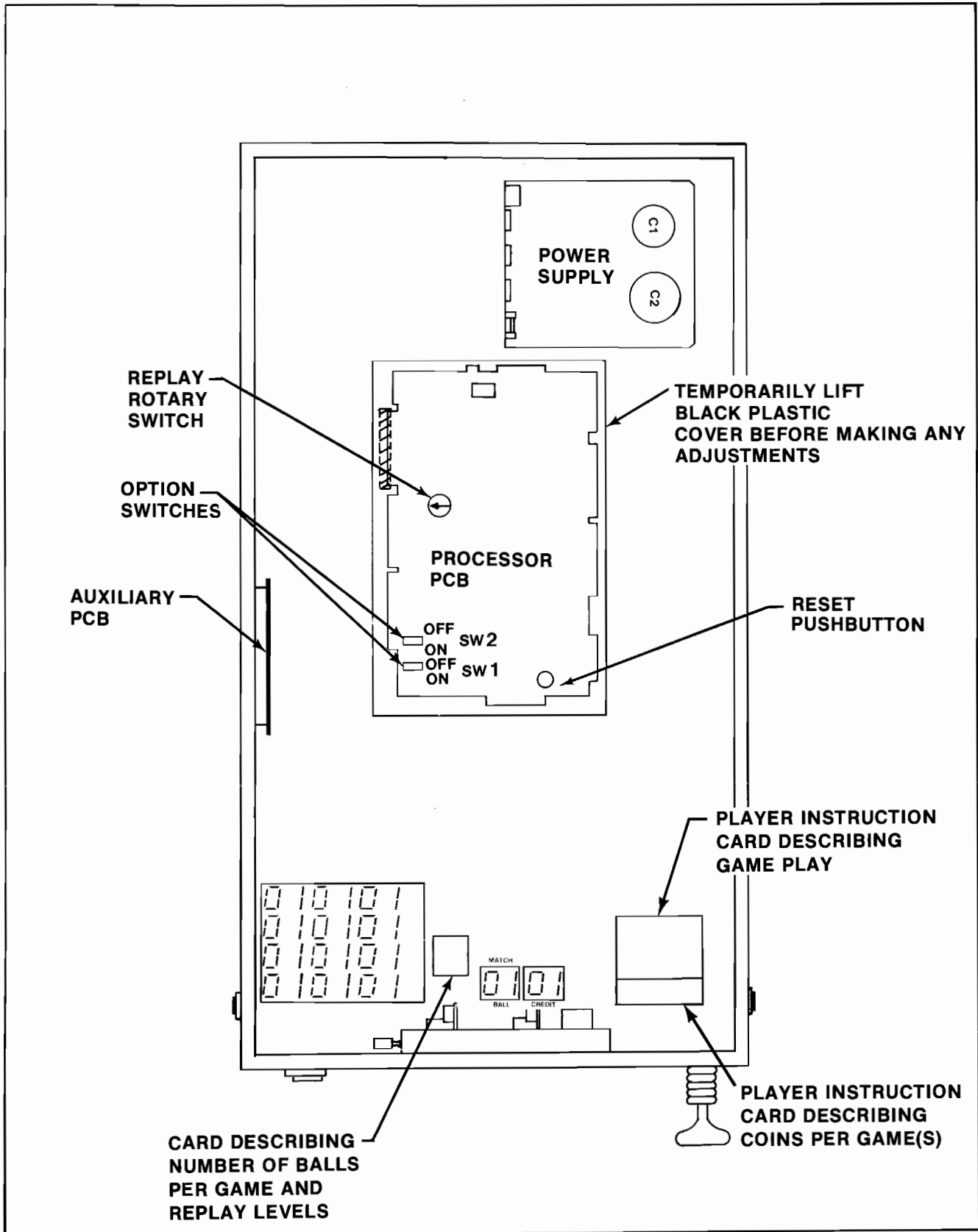

Figure 5 Location of Option Switches

### REPLAY/ADD-A-BALL LEVEL SETTINGS

(normal levels)

1ST Replay/ Add-A-Ball Level	2ND Replay/ Add-A-Ball Level	REPLAY Rotary Switch	PROG SW1 Toggle 7
No Replay/Add-A-Ball		0	ON
40,000	60,000	1	ON
50,000	70,000	2	ON
60,000	90,000	3	ON
70,000	100,000	4	ON
80,000	110,000	5	ON
90,000	120,000	6	ON
100,000	130,000	7	ON
110,000	140,000	8	ON
120,000	150,000	9	ON
130,000	160,000	10	ON
140,000	170,000	11	ON
160,000	200,000	12	ON
180,000	220,000	13	ON
200,000	250,000	14	ON
220,000	270,000	15	ON

### REPLAY/ADD-A-BALL LEVEL SETTINGS

(5 times multiplied)

1ST Replay/ Add-A-Ball Level	2ND Replay/ Add-A-Ball Level	REPLAY Rotary Switch	PROG SW1 Toggle 7
No Replay/Add-A-Ball		0	OFF
200,000	300,000	1	OFF
250,000	350,000	2	OFF
300,000	450,000	3	OFF
350,000	500,000	4	OFF
400,000	550,000	5	OFF
450,000	600,000	6	OFF
500,000	650,000	7	OFF
550,000	700,000	8	OFF
600,000	750,000	9	OFF
650,000	800,000	10	OFF
700,000	850,000	11	OFF
800,000	950,000	12	OFF
800,000	950,000	13	OFF
850,000	950,000	14	OFF
850,000	950,000	15	OFF

#### NOTES:

1. SECOND Replay/Add-A-Ball score is *eliminated* by setting PROG SW1, toggle 3, to OFF.
2. To *have* SECOND Replay/Add-A-Ball score, set PROG SW1, toggle 3, to ON.

### BALLS PER GAME SETTINGS

3 Balls—set PROG SW2, toggle 1 to OFF  
5 Balls—set PROG SW2, toggle 1 to ON

### MAXIMUM CREDITS PER GAME SETTINGS

5 credits—set PROG SW1, toggles 5 and 6 OFF  
10 credits—set PROG SW1, toggles 5 ON and 6 OFF  
15 credits—set PROG SW1, toggles 5 OFF and 6 ON  
20 credits—set PROG SW1, toggles 5 and 6 OFF

### COINS PER GAME SETTINGS

		PROG SW 2 toggles			
Left Coin Chute	Right Coin Chute	3	4	5	6
1 coin/1 credit	1 coin/1 credit	OFF	OFF	OFF	OFF
1 coin/2 credits	1 coin/2 credits	ON	OFF	OFF	OFF
1 coin/3 credits	1 coin/3 credits	OFF	ON	OFF	OFF
1 coin/4 credits	1 coin/4 credits	ON	ON	OFF	OFF
*2 coins/1 credit	2 coins/1 credit	OFF	OFF	ON	OFF
*2 coins/3 credits	2 coins/3 credits	ON	OFF	ON	OFF
*2 coins/5 credits	2 coins/5 credits	OFF	ON	ON	OFF
*2 coins/1 credit	1 coin/1 credit	ON	ON	ON	OFF
1 coin/1 credit	1 coin/2 credits	OFF	OFF	OFF	ON
1 coin/2 credits	1 coin/4 credits	ON	OFF	OFF	ON
1 coin/3 credits	1 coin/6 credits	OFF	ON	OFF	ON
*2 coins/3 credits	*2 coins/7 credits	ON	ON	OFF	ON
*2 coins/5 credits	1 coins/5 credits	OFF	OFF	ON	ON
2 coins/7 credits	1 coin/7 credits	ON	OFF	ON	ON
**3 coins/1 credit	1 coin/1 credit	OFF	ON	ON	ON
1 coin/1 credit	1 coin/3 credits	ON	ON	ON	ON

\*Indicates that 2nd coin results in one more credit than 1st coin, provided that no scoring takes place between coins.

\*\*Indicates that no credits until second coin.

### SCORE MULTIPLIER SETTING

All scores same as indicated on playfield—  
set PROG SW1, toggle 7 ON  
All scores five times indicated value on playfield—  
set PROG SW1, toggle 7 OFF



### EXTRA BALL SEQUENCE SETTING

Extra ball awarded for completing Extra Ball sequence  
 set PROG SW1, toggle 2 to ON.  
 10,000 points (50,000 points if 5X multiplier is on)  
 for completing Extra Ball sequence—  
 set PROG SW1, toggle 2 to OFF.

### BONUS ADVANCE FEATURE SETTING

Bonus advance as indicated on playfield—  
 set PROG SW1, toggle 4 ON.  
 Bonus advance as indicated on playfield, plus double  
 bonus advance on last ball—  
 set PROG SW, toggle 4 to OFF.

### MATCH FEATURE SETTINGS

Match ON—set PROG SW2, toggle 2 to ON.  
 Match OFF—set PROG SW2, toggle 2 to OFF.

### SPECIAL FEATURE SETTINGS

Replay—set PROG SW2, toggles 7 and 8 to ON.  
 Extra Ball—set PROG SW2, toggle 7 to ON and  
 toggle 8 to OFF.  
 10,000 points (50,000 points if score multiplier is ON)  
 set PROG SW2, toggle 7 OFF and toggle 8 to ON.  
 200,000 points (100,000 points if score multiplier is ON)  
 set PROG SW2, toggle 7 and 8 to OFF.

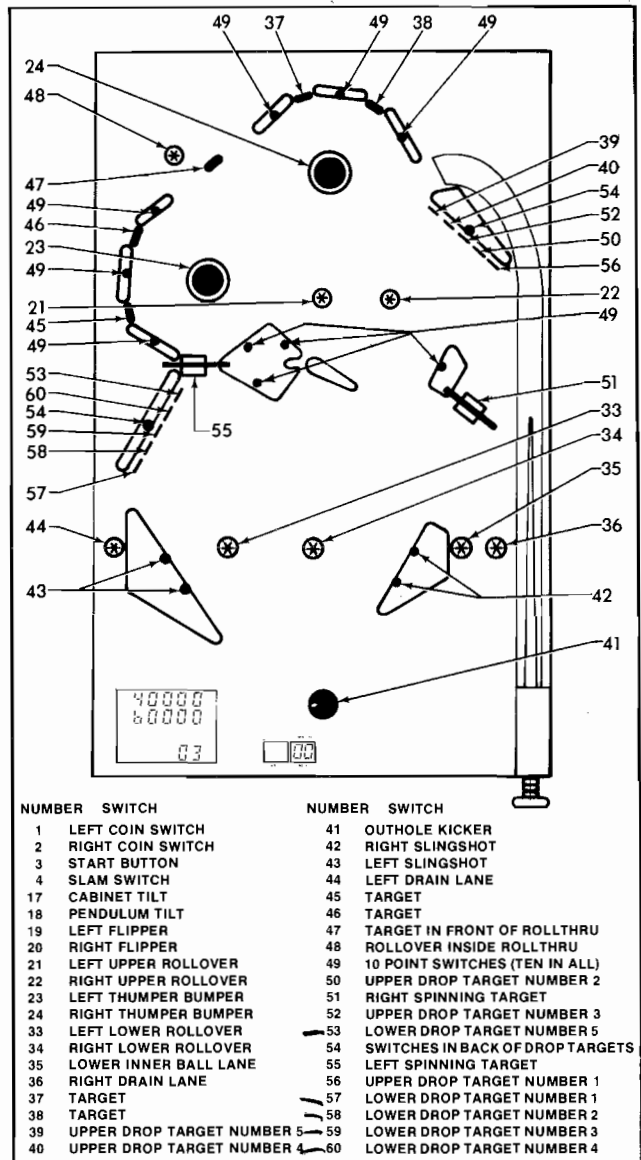
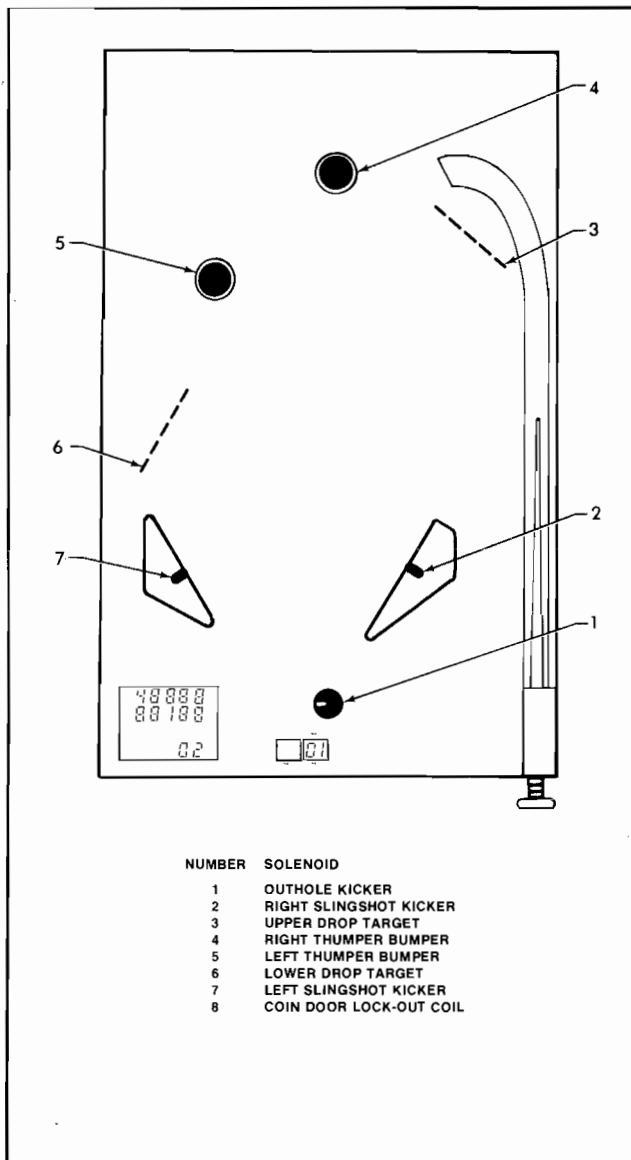

Figure 6 Location of Playfield Solenoids and Switches

Table 1 Self-Test Procedure

Test Name	Test Instruction	Indication of Test Mode	Test Results	Operator Action
Lamp Test	See Notes 1 and 2. Press and release (once only) TEST pushbutton located on inside top middle of coin door.	(Test number) 1 appears in 4TH UP score display.	<p>All lamps are lighted (ignore back box lamps).</p> <p>If elimination of SECOND WIN is selected, SECOND UP score is blank.</p> <p>If SECOND WIN is selected, SECOND WIN score is displayed in 2ND UP score display.</p> <p>The FIRST WIN score displayed in 1ST UP score display.</p> <p>Number of balls per game is displayed in BALL display.</p> <p>Maximum credits is displayed in the CREDIT display.</p>	<p>Check to ensure that all playfield lamps are lighted.</p> <p>To add SECOND WIN score, set PROG SW1, toggle 3 to ON.</p> <p>To eliminate SECOND WIN, set PROG SW1, toggle 3 to OFF.</p> <p>To change WIN values, adjust REPLAY rotary switch and PROG SW1, toggle 7 for the results as listed in the WIN SCORE SETTINGS below.</p> <p>Please note that by setting the score multiplier switch, PROG SW1, TOGGLE 7 to OFF, all playfield scores are multiplied by 5. Check that WIN level displayed on the Playfield lower arch. For an ADD-A-BALL award for the WIN score, set PROG SW1, toggle 8, to OFF. For a REPLAY award for the WIN SCORE, set PROG SW7, toggle 8, to ON.</p> <p>To change, set PROG SW2, toggle 1, to ON for 3-ball game, OFF for 5-ball game.</p> <p>To change, set PROG SW1, toggle 5 and 6 as listed in CREDITS PER GAME SETTINGS below.</p> <p>NOTE: To exit Self-Test, press and release TEST pushbutton 3 times.</p>
Solenoid Test	<ol style="list-style-type: none"> <li>Press and release (once only) TEST pushbutton.</li> <li>Press and release START</li> </ol>	(Test number) 2 appears in 4TH UP score display.	<p>Playfield solenoids are activated, then deactivated one at a time. As each solenoid does so, a number identifying that solenoid is displayed in CREDIT display. The solenoid is activated only once</p>	<p>Listen and watch for playfield solenoids being activated then deactivated in the following order.</p>

	pushbutton. 3. Press right and left flipper buttons.		each. To repeat activation, press and release START pushbutton.  Right and left flippers are activated.	<p>Number in Credit Display      Solenoid</p> <p>1    Outhole Kicker 2    Right Slingshot Kicker 3    Upper Drop Target 4    Right Thumper Bumper 5    Left Thumper Bumper 6    Lower Drop Target 7    Left Slingshot Kicker 8    Coin Door Lock-Out Coil</p> <p>NOTE: To exit Self-Test, press and release TEST pushbutton 2 times.</p>
Switch Test	Press and release (once only) TEST pushbutton.	(Test number) 3 appears in 4TH UP score display.	Any activated or stuck switches are identified by a number in the CREDIT display. A pulsing tone is heard when a switch is activated or stuck.	Identify activated or stuck switches as shown in Figure 6.  NOTE: To exit Self-Test, press and release TEST pushbutton 1 time.
Volume Adjustment	Activate left or right coin acceptor switch.	Repeated "oink" sound is emitted from the game speaker.		Reach through coin door and adjust volume control (located behind and above the game speaker) for the desired volume.
Display check	Press and release (once only) TEST pushbutton.		All displays (SCORE, BALL, and CREDIT) have an 8 in each number location.	Check that all displays have 8s. Displays will go blank in less than 30 seconds. To have displays to stay lit longer, set ON/OFF switch (located under right front corner of cabinet) to OFF, then ON.

- NOTES: 1. PROG SW1, toggle 1, must always be set to OFF.  
2. Game will enter Self-Test from any mode. However, when Self-Test is entered, all credits (if any) are erased from the credit accumulator.  
3. If score multiplier is used, attach the "ALL SCORING 5 TIMES" label to the Playfield lower arch.

1 also lists all the options and the switches necessary to set those options. In these tables, all manufacturer suggested settings are marked with dollar signs. Figure 5 shows the location of each switch on the Processor PCB (printed circuit board). To set the switches, slightly press down on the selected switch toggles with a small pointed object. To set the toggle to *on*, press on the switch side toward the closest end of the Processor PCB.

## **E. SELF-TEST**

Self-Test is activated by pressing the TEST pushbutton. The Test pushbutton is located at the inside top middle of the coin door. Pressing the pushbutton once begins the lamp test; pressing the pushbutton twice begins the solenoid test; and the third time, the switch test. Pressing the pushbutton the fourth time causes the game to exit the Self-Test mode and enter the attract mode of operation.

Now perform the Self-Test Procedure described in Table 1. As an aid for locating the playfield switches and solenoids, see Figure 6.

## **F. VOLUME ADJUSTMENT**

The volume control for all game sounds is located inside the cabinet above and to the right of the game speaker. To adjust the volume, turn the volume control clockwise to increase the volume and counter-clockwise to decrease the volume.

A second volume control is located inside the cabinet on the Auxiliary PCB (labeled VOL). This volume control should only be adjusted by a qualified technician. Technicians may learn the proper adjustment of this control by reading the instructions in the maintenance chapter (Chapter 3) of this manual.

# GAME PLAY

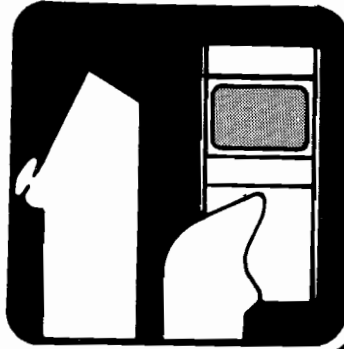

The game has three modes of operation: attract, play, and Self-Test. The attract mode serves to attract players to the game. The play mode is active when the game is being played. Self-Test is used by the operator for game maintenance.

## A. ATTRACT MODE

The attract mode is initiated by game power-up, exit from Self-Test, or by the end of the previous game. If entered from power-up or Self-Test, the score and match/credit displays will indicate all eights. If the attract mode follows a game, the score will indicate the final score of that game. When the game is powered up, or exited from the test mode, the display will go blank after approximately 30 seconds. After the end of a game, the machine will sequence through each player's score.

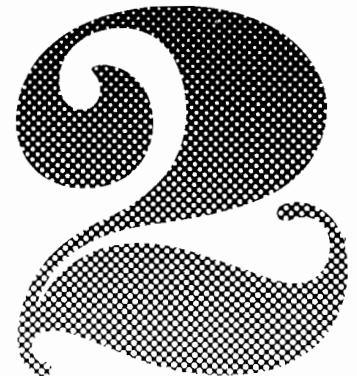

In the attract mode, the playfield lamps blink on and off in an exotic light show that attracts potential players to the game. The game remains in this mode unless a player presses the START pushbutton (if there are sufficient accumulated credits) or by the operator entering the Self-Test mode by pressing the TEST pushbutton.

## **B. PLAY MODE**

After a player has depressed the START button, the game responds as follows:

1. The uppermost row in the Score Panel will indicate two zeros, and the words *1ST UP* to the right of the zeros will start to blink on and off.
2. The number in the Credit Display decreases by 1.
3. The Match Display will now become the Ball Display and will indicate *01*, meaning that the first game ball is in play.
4. The ball is ejected from the outhole and rolls over to the ball shooter.
5. The playfield lamps will stop blinking, and 1000 and BALL IN PLAY lamps will be constantly lighted. All other score-related lamps remain unlighted.
6. The flipper controls are enabled.
7. On the player panel just above and beside the ball shooter, the lamp behind the numeral *1* (surrounded by yellow) will light, indicating that so far one player is playing.

Up to this point and even up until the ball hits the first score point object, additional players may be added to the game. They do this by depositing money (if necessary), and by then depressing the START pushbutton. Each time the game responds by adding

another row of two zeros in the Score Panel, decreasing the Credit Display by 1, and lighting another lamp just above the ball shooter.

If a ball rolls all the way down to the outhole without achieving any score whatsoever, the outhole kicker will then eject the ball so that the player can shoot again. But if a ball achieves any score it is counted as one of the play balls.

As soon as the first score points are earned, the lock-out coil on the coin door is de-energized and the coin mechanisms will not accept any coins until after the play sequence ends.

### **Game Play and Scoring**

1. Drop Targets: Completing either bank lights "EXTRA BALL" in lower inside lane. Completing both banks lights "SPECIAL" in lower inside lane. Completing lower bank twice lights "SPECIAL" in left drain lane. Completing upper bank twice lights "SPECIAL" in right drain lane.
2. Bonus Loop: The first pass through the loop in the upper section of the playfield gives one bonus advance. The second pass gives two advances. Each subsequent pass will give three advances.
3. Ten Times Scoring: Hitting the two standing targets by each thumper increases that thumper from 10 points to 100 points. Hitting the standing target increases the spinning targets 10 points to 100 points. Completing all 5 standing targets increases the star rollovers from 50 points to 500 points.
4. Double Bonus: Double bonus is achieved by activating the 5 unlit star rollovers.
5. If the multiplied scoring option is active, all playfield scores are multiplied by five.

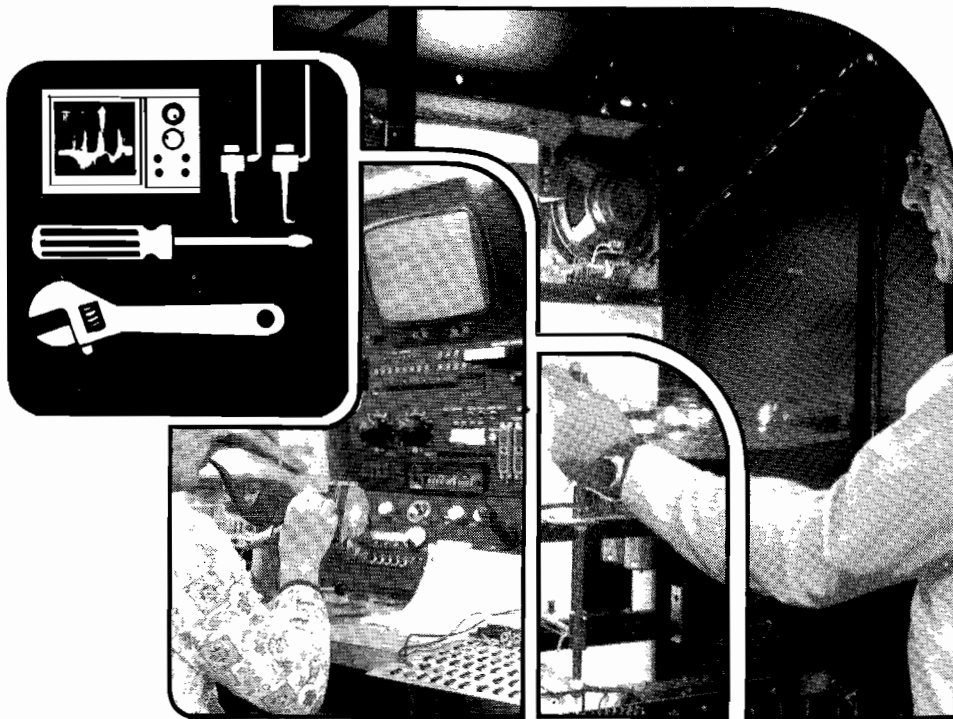

## **MAINTENANCE AND ADJUSTMENTS**

Due to its solid-state electronic circuitry, this Atari game should require very little maintenance and only occasional adjustment. Information given in this chapter and elsewhere in the manual is intended to cover most servicing situations that may be encountered at the game site. The procedures given are in sufficient detail to be understood by a person with moderate technical ability.

### **A. CLEANING**

#### **Game Cabinet Exterior**

The exterior parts of the game cabinet and glass may be cleaned with any non-abrasive household cleaner. If desired, special coin machine cleaners which leave no residue can be obtained from distributors.

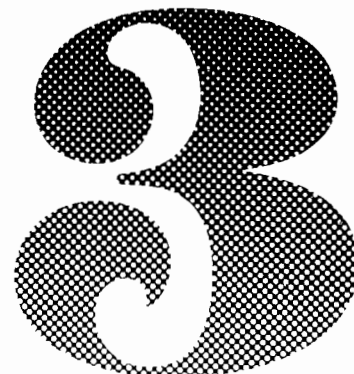

**Table 2 Fuses Located Near Ball Shooter**

Position on Strip	Designation	Circuit Protected	Domestic Fuse Rating	Foreign Fuse Rating
Uppermost fuse	F7	Back Box	2 amps, 250 volts, fast-blow (3AG)	2 amps, 250 volts, fast-blow (3AG)
Middle fuse	F8	Line Power	7 amps, 250 volts, slow-blow (3AG)	4 amps, 250 volts, slow-blow (3AB)
Bottom fuse	F9	Service Outlet	2 amps, 250 volts, fast-blow (3AG)	2 amps, 250 volts, fast-blow (3AG)

**Table 3 Fuses Located on Power Supply Assembly**

Position on Strip	Designation	Circuit Protected	Rating
Uppermost fuse	F6	Audio	2 amps, 250 volts, fast-blow (3AG)
	F5	Displays	0.5 amps, 250 volts, slow-blow (3AG)
	F4	Displays	0.5 amps, 250 volts, slow-blow (3AG)
	F3	Lamps	15 amps, 250 volts, fast-blow (3AB)
	F2	Logic	7 amps, 250 volts, slow-blow (3AG)
Bottom fuse	F1	Solenoids	15 amps, 250 volts, fast-blow (3AB)

**Playfield**

The surface of the playfield has a finish chosen for its long-wearing property. Check the surface periodically to make sure that it is both clean and free of foreign material. Also, periodically check the ball to make sure that it also is smooth and clean. Immediately replace any ball that is chipped, burred, corroded, or pitted. A defective ball will cause damage to the playfield surface in a very short time.

Much of the player appeal in pinball games depends on smooth ball travel over the entire playfield. To keep the playfield and ball from wearing out prematurely, Atari recommends using only a non-abrasive cleaner.

Do *not* use such products as "Formula 409" or "Windex," kitchen cleansers, soapy cleaning pads or steel wool, waxes or polishes, or great amounts of water. These products may easily scour and damage the silk-screened artwork, and/or cause buildup of gummy residue.

While cleaning the playfield, avoid getting foreign material into the bodies of the star rollovers. You might cover the switch body with a small amount of masking tape when cleaning around the switch body.

For replacement sizes of playfield rubbers, see Figure 7.



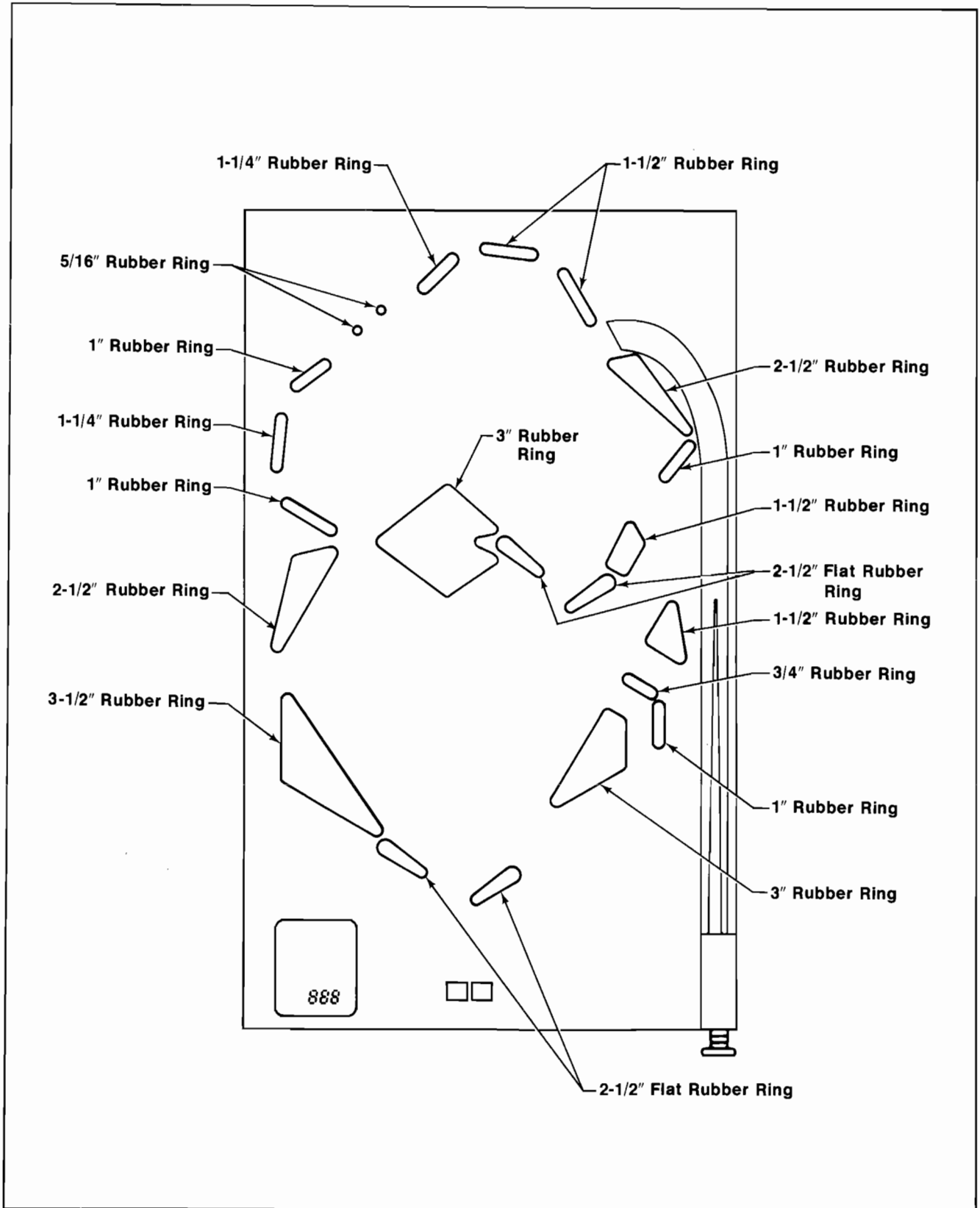

Figure 7 Playfield Rubber Sizes

## B. FUSE REPLACEMENT

### WARNING

As an additional safety measure when replacing fuses, *always* unplug the power cord before opening the cabinet.

### CAUTION

When changing fuses make sure that the replacement fuses have the ratings specified by Atari, and that the fuse is being replaced in the *correct* fuse holder.

Replacement fuse values are listed on charts near both the power supply fuse panel and service panel. In case these fuse value charts have been destroyed, refer to Tables 2 and 3 for the values.

## C. COIN MECHANISM

### Components on Coin Door

Figure 8 shows the back side of the coin door assembly where the game's two coin mechanisms are mounted. Included is the lock-out coil assembly; the lock-out wires are connected to this assembly but are hidden behind the coin mechs. During the attract mode, the microcomputer energizes the lock-out

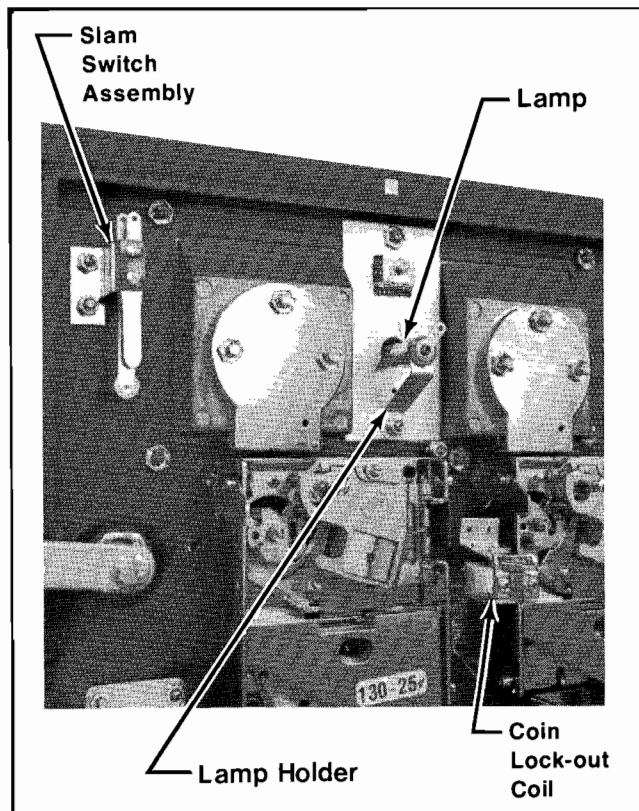

Figure 8 Coin Door Assembly

coil, causing the lock-out wires to retract far enough to allow genuine coins to reach the coin box. During play mode (and also when AC power to the game has been turned off) the lock-out coil is de-energized, causing the lock-out wires to move out far enough to divert coins over to the coin return chute.

Directly below each coin mechanism is a secondary coin chute and a coin switch with a trip wire extending out to the front edge of the chute. When the trip wire is positioned correctly, a coin passing down the secondary chute and into the coin box will momentarily push the trip wire down and cause the switch contacts to close.

Also shown in the photograph is a slam switch assembly. It has been included to defeat any players who might try to obtain free credits by violently pounding on the coin door to momentarily close the contacts on a coin switch. The slam switch contacts connect to the microcomputer system, which will ignore coin switch signals whenever the slam switch contacts are closed.

### Access to Coin Mechanisms

To remove jammed coins, and for maintenance cleaning, each magnet gate assembly can be hinged open without removing it from the door, as shown in Figure 9. Or, if necessary, each coin mechanism can

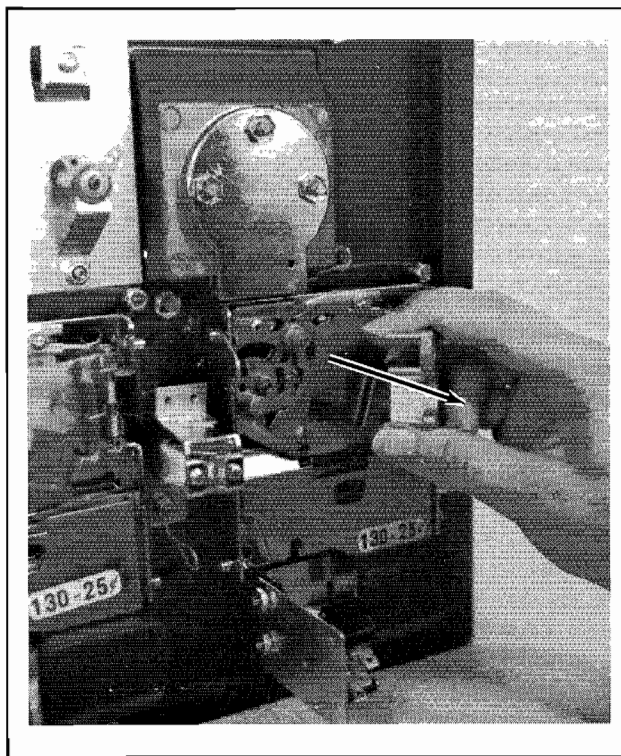

Figure 9 Hinging Open the Magnet Gate Assembly

be entirely removed from the door merely by pushing down on a release lever and simultaneously tilting the mechanism back, then lifting it up and out. This is shown in Figure 10.

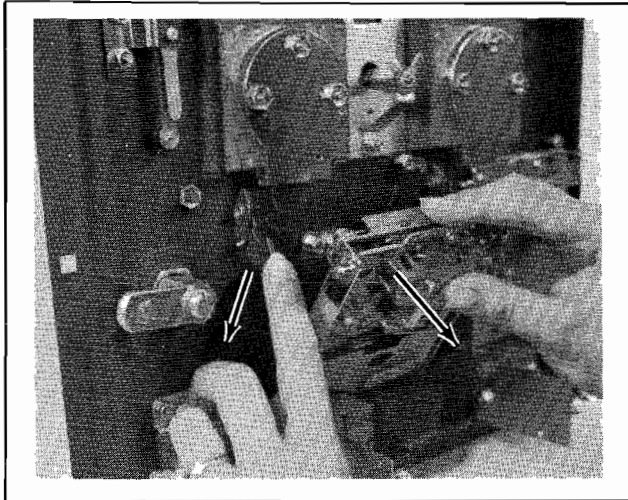

Figure 10 Removal of Coin Mechanism

### Cleaning of Coin Paths

#### CAUTION

The use of an abrasive (such as steel wool or a wire brush) or a lubrication on a coin mechanism will result in a rapid buildup of residue.

By talking to many operators, we have found that the best method of cleaning a coin mechanism is by using hot or boiling water and a milk detergent. A toothbrush may be used for those stubborn buildups of residue. After cleaning, flush thoroughly with hot or boiling water, then blow out all water with compressed air.

Figure 11 shows the surfaces to clean inside the coin mechanism. These include the inside surface of the mainplate, and the corresponding surface of the gate assembly. There may also be metal particles clinging to the magnet itself. To remove these you can guide the point of a screwdriver or similar tool along the edge of the magnet.

If coins are not traveling as far as the coin mechanisms, you will need to clean the channel beneath the coin slot. To gain access to this channel, use a  $\frac{3}{8}$ -inch wrench and remove all three nuts that secure the cover plate (refer to Figure 12). Removing the plate will provide access to the entire channel.

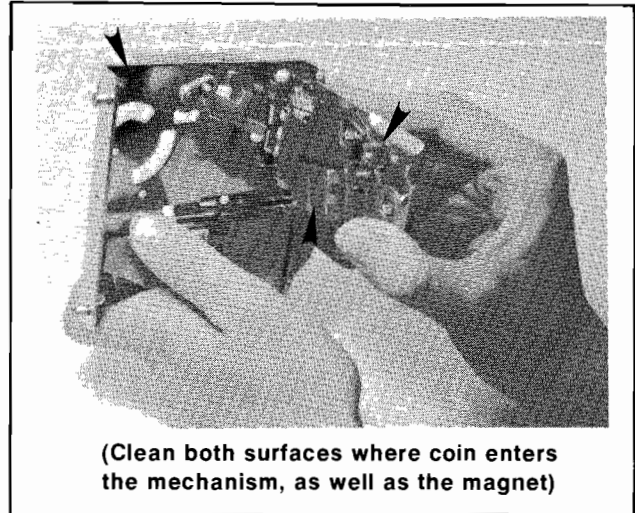

Figure 11 Surfaces to Clean Inside the Coin Mechanism

Also clean the inside surfaces of the secondary coin chutes, but when doing this be careful not to damage or bend the trip wires on the coin switches.

### Adjustment of Coin Switch Trip Wire

In order for a coin switch to operate reliably when a coin travels down the secondary coin chute, the rest position of the switch's trip wire should be as shown in Figure 13. Use extreme care when handling or touching these wires.

Three problems can occur with trip wires—they can be too long, too short, or become loosened and fall off.

With a too long wire, you may have a problem of it catching on the opening in the cash box as a coin is accepted. You can cut off the end of the wire in small increments, making sure it still extends slightly through the "V" of the coin chute.

If the trip wire is too short (either by wrong adjustment or by being cut off too much), then coins may slip by the wire without tripping it, and *no* credits will be given. The solution is to carefully bend and somewhat straighten out the wire to lengthen it. If you cannot straighten it enough, then you will have to contact your distributor to order another trip wire.

If the wire is loose and falls off of its mounting stud, it will also cause *no* credits to be given. Secure the wire by crimping together both ends of the brass-colored mounting stud with a pair of pliers (also see Figure 13). If you should ever need to remove the

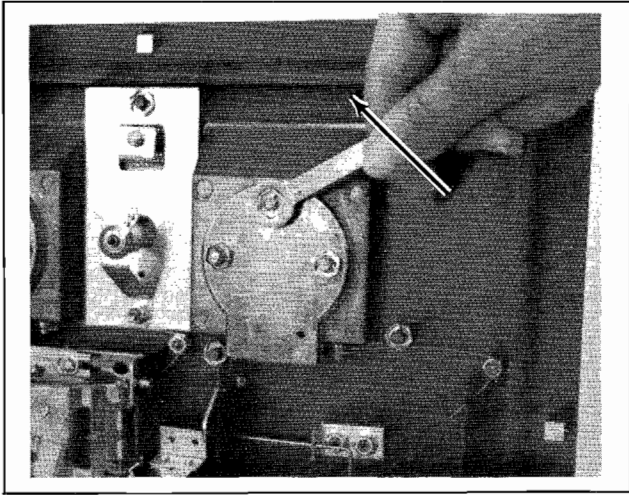

**Figure 12** Removal of Plate Covering Rear of Coin Slot

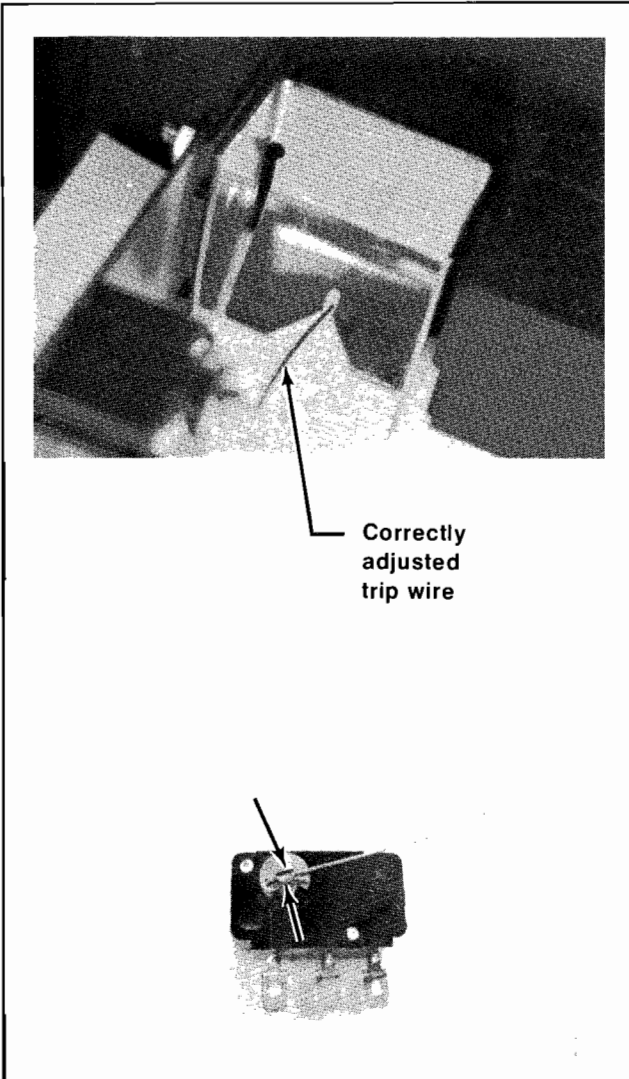

**Figure 13** Detail View of Coin Switch and Trip Wire

trip wire, the two halves of the mounting stud can be separated with a small screwdriver.

**Mechanical Adjustments on Coin Mechanism**

Coin mechanisms are adjusted prior to shipment from the factory and normally will retain these adjustments for many months. If, due to wear or other causes, it becomes necessary to make new adjustments, remove the coin mechanism from the coin door. Then take it to a clean well-lighted area where it can be placed in a vertical position on a level surface (such as a bench top). Besides a screwdriver, you will need a set of several coins, including both new and old. Figure 14 shows an exploded view of the mechanism and gives procedures for adjusting the kicker, separator, and the magnet gate. These adjustments should only be done by someone who has experience in servicing coin mechanisms and who understands their operation.

**Lubrication**

Do *not* apply lubrication to the coin mechanisms. The only points that may need lubrication (and only rarely) are the shafts of the scavenger buttons (coin rejection buttons) where they pass through the coin door. Apply only one drop of light machine oil, and be positive that no oil drops down onto a coin mechanism. Figure 15 shows this lubrication point.

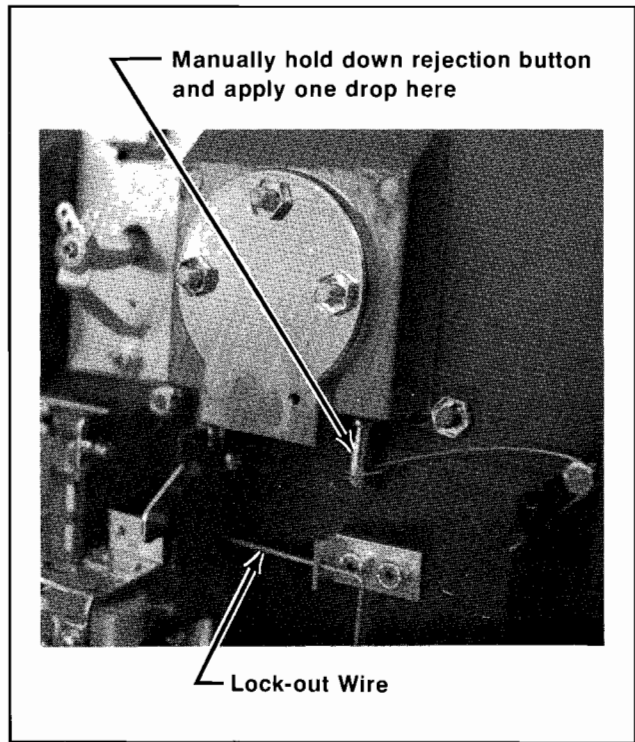

**Figure 15** Close-up View of Lubrication Point

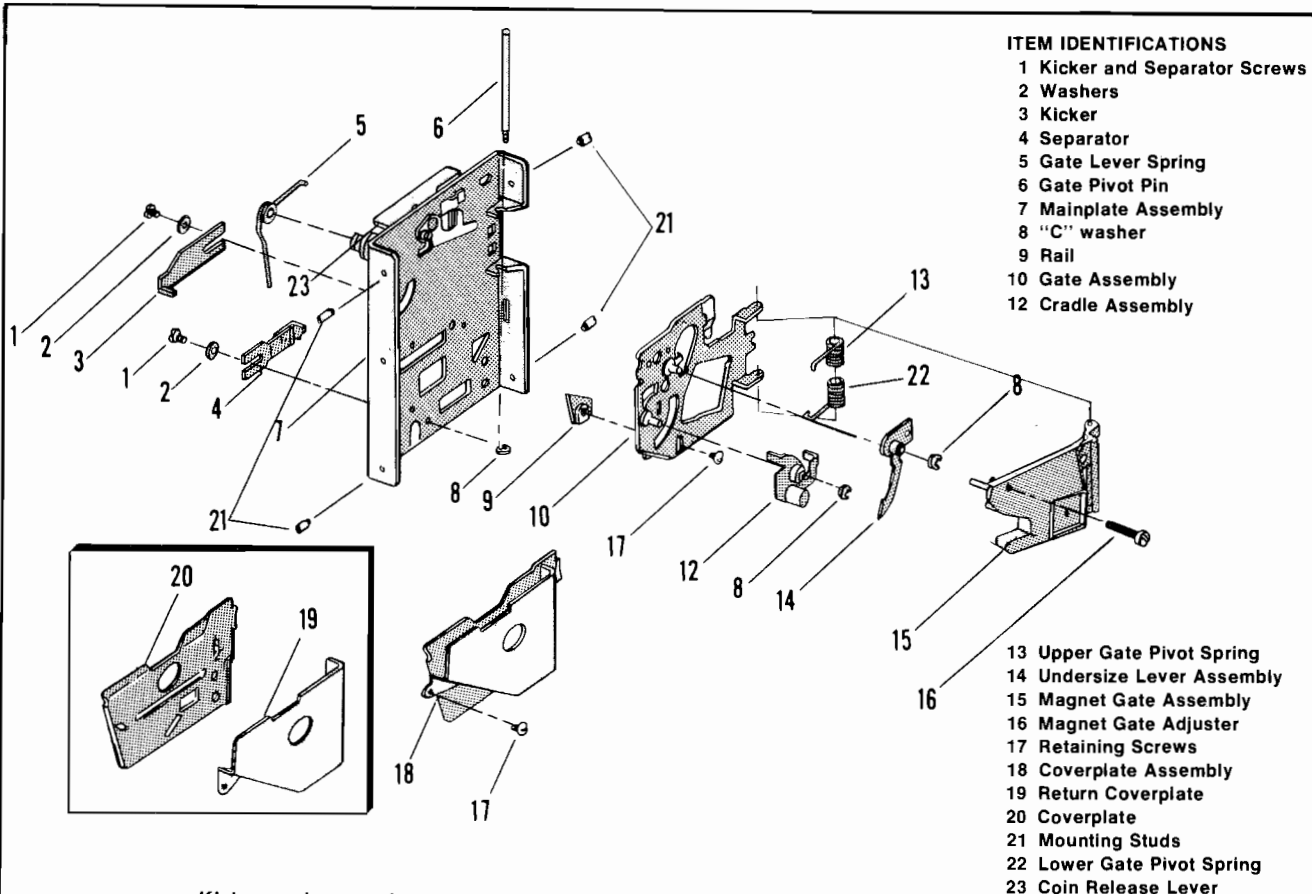

**Kicker and separator**

1. Set the acceptor with the back of the unit facing you in the test position.
2. Loosen the kicker and separator screws (1) and move the kicker (3) and the separator (4) as far to the right as they will go. Lightly tighten the screws.
3. Insert several test coins (both old and new) and note that some are returned by striking the separator.
4. Loosen the separator screw and move the separator a slight amount to the left. Lightly retighten the screw.
5. Insert the test coins again and, if some are still returned, repeat Step 4 until all the coins are accepted.
6. Loosen the kicker screw and move the kicker as far to the left as it will go. Lightly retighten the screw.
7. Insert the test coins and note that some are returned.
8. Loosen the kicker screw and move the kicker a slight amount to the right. Lightly retighten the screw.
9. Insert the test coins again and, if some are still returned, repeat Step 8 until all the coins are accepted.
10. Be sure that both screws are tight after the adjustments have been made.

**Magnet gate**

1. Set the acceptor with the front of the unit facing you in the test position.
2. Turn the magnet gate adjusting screw (16) out or counterclockwise until none of the coins will fit through.
3. With a coin resting in the acceptor entrance, turn the adjuster in or clockwise until the coin barely passes through the magnet gate.
4. Test this adjustment using several other coins (both old and new) and, if any fail to pass through the magnet gate, repeat Step 3 until all the coins are accepted.
5. Fix the magnet gate adjusting screw in this position with a drop of glue.

**Additional Cleaning**

- 1) Remove the transfer cradle (12) and the undersize lever (14).
- 2) Use a pipe cleaner or similar effective cleaning tool to clean the bushings and pivot pins.
- 3) Replace the transfer cradle and the undersize lever.
- 4) To be certain the coin mechanism is completely free of any residue, place the mechanism in boiling water for several minutes. Carefully remove it and let it air-dry completely before reinstalling in the door.

Figure 14 Adjustments on Coin Mechanism

## General Troubleshooting Hints

The first action is to look for jammed coins. After these have been removed, examine the coin path for presence of foreign material or loose objects (such as chewing gum, small metallic objects, paper wads, etc.). In cases where game usage is heavy, it may be necessary to clean the entire coin path periodically, in order to prevent build-up of contaminants that can hinder the movement of coins through the mechanisms. Also confirm that the trip wire on each coin switch is intact, and is properly adjusted. If troubles still persist, check the conditions and positions of the lock-out wires, and the mechanical adjustments on the coin mechanisms, before suspecting the electronics. If a coin mechanism rejects genuine coins, try to readjust it. If this is not successful, then replace it with a working mechanism.

Correct operation of the slam switch can be verified by putting the game into the test mode and performing the switch test (described in Table 1). Correct operation of the other switches and of the lock-out coil can also be checked by the switch test, or else merely by manually operating them and watching game responses as it changes from the attract mode to play mode, and then back to attract mode again.

## D. GAME CONTROLS AND PLAYFIELD COMPONENTS

Opening the cabinet and raising the playfield will give access to the playfield components and the game controls—*START* pushbutton switch, flipper switches, pendulum tilt and cabinet tilt switches, Power On/Off Switch, speaker, and the ball shooter.

The game's microcomputer system improves game reliability and significantly reduces maintenance requirements because it replaces conventional electromechanical devices such as step-up rotary switches and motorized trip relay banks. Another game feature is that adjustment-free sealed-contact switches replace all open-contact blade-type switches.

### Solenoid Fuses

Plugged onto connector J8 on the Processor PCB is a special miniature PCB assembly that provides individual fuses for each solenoid line. This assembly is identified by the Atari part number A020383. These fuses have been added to prevent the driver transistor from overheating and damaging the surface of the PCB if current flow starts to exceed the maximum fused value.

Whenever a fuse is found to be open, perform the following two checks before replacing the fuse. After making sure that AC power to the game is shut off, first use an ohmmeter to measure the solenoid's DC resistance. Flipper solenoids should have a DC resistance of approximately 7.7 ohms. Hole kickers should have a DC resistance of approximately 18 ohms. The gate solenoids should read approximately 200 ohms with ohmmeter connected in one direction and about 15 ohms with the instrument connected in other direction. Secondly, use the ohmmeter to check the collector-emitter junction of the 2N6044 driver transistor.

Replace only with 2 amp, 125 volts, slo-blo (3AG) fuses.

### Troubleshooting of Playfield Switches Connected in Parallel

As described in Chapter 1, Section D, you can use the switch test both for automatically detecting switches with stuck contacts and for manually identifying switches with stuck contacts and for manually identifying switches whose contacts are not closing properly. But in the instance where contacts from two switches are connected in parallel, additional troubleshooting steps will be needed in order to verify whether or not a given switch is defective.

For example, switch test #49 simultaneously checks all 10-point switches. To confirm which switch is defective, one at a time you must temporarily unsolder the wire to the normally-open contact of each switch, while leaving the other switch still connected. Then perform the switch test separately for each switch connected alone.

Wiring connections to the playfield switches are shown in Chapter 4 in the Wiring Diagram, Sheet 2.

## E. GAS-DISCHARGE DISPLAYS

The displays are designed to be maintenance-free, so they normally require attention only if incorrect operation is observed. Use the following procedures to isolate and correct problems with the displays.

### Preliminary Operational Checks

Make sure that the coin door is closed and locked. Then plug in the power cord and place the Power On/Off Switch in its *on* position. Immediately after AC power is applied, the Score Display should be showing all 8s and the *PLAYER UP* indications (1ST UP, 2ND UP, etc.) light one at a time, in numerical sequence. All 8s should be showing in the Credit Display and the Match/Ball Display.

The displays are all operating properly if every display segment lights up at least once. But if one or more segments remain dark, isolate the problem circuitry as described in the following subsection.

### Check on +90 and -90 Volts Power Supply Voltages

Remove the playfield glass, then remove the lower arch panel. Troubleshoot the displays as follows:

#### WARNING

Whenever AC power is applied to the game, voltage potential differences as large as 180 volts are present at the bare terminals of the score panel's edge connector J21, and at various other points on both printed circuit boards.

1. Defeat the Interlock Safety Switch by pulling all the way out on the switch's spring-loaded plunger.
2. Place the Power On/Off Switch in the *on* position.
3. Connect a voltmeter across the following capacitors shown in Figure 16, and check for the readings listed below:

On *Match/Credit Display PCB*, place meter's ground lead on "plus" side of C2; other lead

placed on "plus" side of C1 gives +90 volts reading, and on "minus" side of C2 gives -90 volts reading.

On *Score Panel PCB*, place ground lead on "plus" side of C2; other lead on "plus" side of C1 gives +90 volts reading, and on "minus" side of C2 gives -90 volts reading.

4. If one or more readings are low (or at zero volts), check each PCB separately as follows. Disconnect J19 and re-measure the voltages on the Score Display PCB. If the voltages are OK, then some portion of the circuitry on the Match/Credit Display PCB is pulling down the supply voltages. If the voltages are still incorrect, reconnect J19, disconnect J17, and re-measure the voltages on the Match/Credit Display PCB. If voltages are OK, then some portion of the circuitry on the Score Display PCB is pulling down the supply voltages.

If the voltages remained incorrect while each board was checked separately, leave J17 and J19 both disconnected. Then check the +90 volt and -90 volt outputs on the Auxiliary PCB (where the high voltage power supply circuitry is located). These 90-volt supply voltages must both be present on each display PCB before the displays can light up.

If all voltage readings on the display PCBs are within 5% of the correct values, then go on to the next portion of the procedure.

### Score Panel Removal and Visual Checks

After the +90 volt and -90 volt supply voltages have been verified, the next troubleshooting step on the score panel will be to remove it from connector J21.

1. Turn off AC power to the game, preferably by pulling out the power plug from the wall outlet.
2. Remove the metal clips holding the score panel onto the bracket arms of J21 (refer to Figure 17).
3. Loosen nylon screws that position the score panel into the score panel connector (refer to Figure 17).

#### WARNING

Glass edges of score panel may be sharp. Use caution to prevent cutting your hands.

4. Using your right hand, grasp the right edge of the score panel. Carefully lift it up approximately ¼-inch, and then pull it straight out and remove it completely.

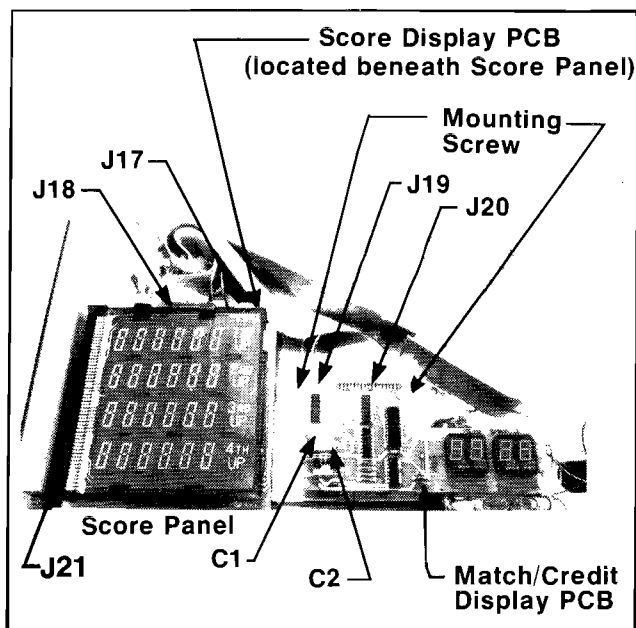

Figure 16 Top View of Score and Match/Credit Display Assembly

5. Examine the positions of the terminal pins on J21. Tips of the pins should be aligned in the same plane, as shown in the detail view of Figure 17. If not bent out of alignment, all pins can then make contact with the score panel's terminal strips when the panel is plugged in.
6. Next examine the condition of the terminal strips on the score panel. If the surfaces of the strips are corroded, use a pencil eraser to clean them off. Be careful, however, not to rub the eraser against any of the tiny metal ribbons touching certain strips up near the glass "seal" (refer to Figure 18). These ribbons must be perfectly centered over the correct pins, not halfway off.

**Replacement of Score Panel**

After the visual checks have been made on the J21 terminal pins and on the score panel, the original

score panel can be put back, or else a new score panel can be substituted in its place. Carefully observe the following procedure when replacing the score panel.

1. Using both hands, grasp the right-hand edge of the panel and carefully slide it fully into connector J21. Then lower the edge down until the entire panel rests in the bracket arms. Adjust the two nylon screws on each side of the score panel connector until score panel terminals are perfectly aligned (refer to Figure 17). At the factory a rubbery substance called RTV was placed between the bracket arms and the score panel. This substance provides a cushion between the glass panel and the metal arms, and positions the panel so that connector J21's terminal pins line up exactly with the panel's terminal strips.

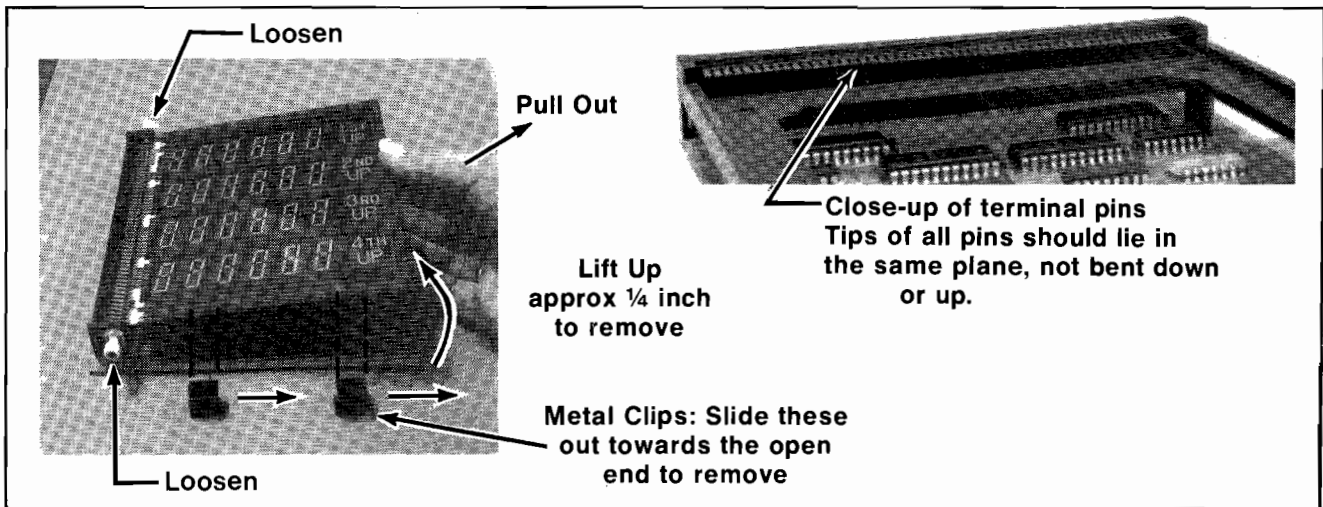

Figure 17 Removal of Score Panel

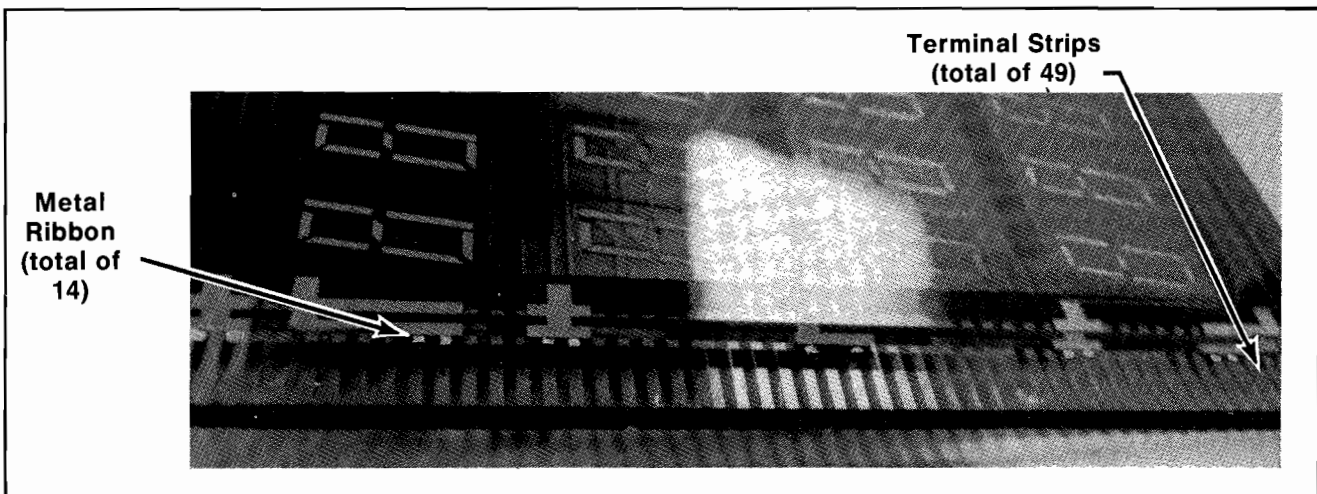
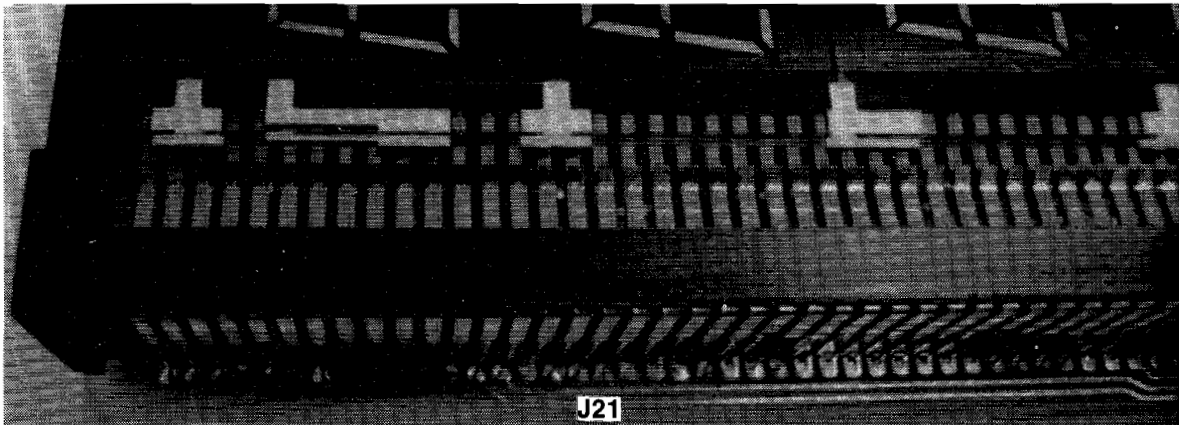
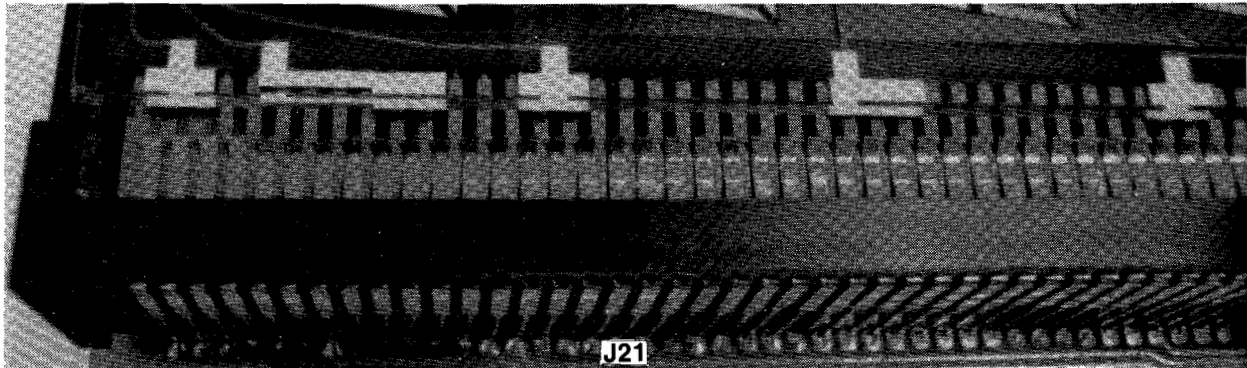

Figure 18 Score Panel Terminals





**CORRECT**  
 Note that terminal strips of Score Panel do line up with terminal pins in score panel connector.



**WRONG**  
 Note that terminal strips of Score Panel do not line up with terminal pins.

Figure 19 Line-up of Terminal Pins and Terminal Strips

2. Replace the metal clips that fasten the score panel to the bracket arms.

4. Lift the entire assembly up and remove it from the playfield.

### Removing Display Assembly

Certain portions of the PCBs are accessible for troubleshooting when the display assembly is left mounted on the playfield. However, to gain access to the remaining portions, or to replace components or an entire PCB, use the following procedure.

1. Turn off AC power to the game, preferably by pulling out the power plug.
2. Disconnect connectors J17, J18, J19, and J20.
3. Use a Phillips-head screwdriver to loosen the four screws that fasten the display assembly to the playfield, and then remove the screws.

### Installing the Display Assembly

After repair and/or replacement of the display boards and displays, use the following procedure to re-attach the assembly to the playfield.

1. Lower the assembly down into its final position and line up the four mounting holes with their mating holes in the playfield. Be careful not to pinch the lamp wires that are routed through a slot at the lower right corner of the assembly (refer to Figure 20).
2. Insert the four mounting screws and use a Phillips-head screwdriver to tighten them down.

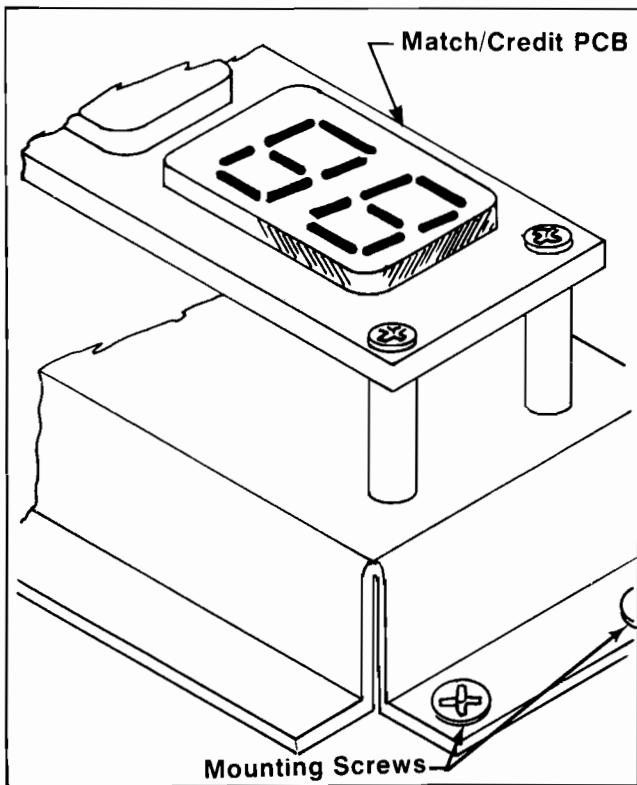

Figure 20 Lower Right Corner of Display Assembly

3. Connect connectors J17, J18, J19, and J20.

## F. LAMP REPLACEMENT

To insure continued player appeal for the game, you should periodically check for burned-out playfield and back box lamps, and replace defective ones *immediately*.

### Playfield Lamps

#### CAUTION

When replacing playfield lamps use #47 bulbs only; other bulb types may cause damage to the lamp driver circuits.

If you suspect a burned out lamp, replace lamp with a neighboring "known to be good" lamp. This will establish whether the lamp is bad or a bad lamp socket or lamp driver.

#### WARNING

Make sure game power is turned off before replacing lamps. This is especially important if the lower arch panel has to be removed to gain access to the lamps beneath it. Whenever AC power is applied to the game, voltage potential differences as large as 180 volts are present at the bare terminals of the score panel's edge connector J21, and at various other points on both display printed circuit boards.

### Back Box Lamps

When replacing these lamps use 7.5-watt bulbs. If the lamp is to flash on and off, remember to place a flasher unit (button-shaped disc) in the socket before inserting and tightening down the bulb.

## G. ADJUSTMENT OF SPEAKER VOLUME

Middle Earth contains two volume controls. One is conveniently mounted inside the cabinet so the operator may adjust the volume without raising the playfield. The other volume control is mounted on the Auxiliary PCB (see Figure 21) and should never be adjusted after being set once.

#### WARNING

Dangerous voltages are present on the Auxiliary PCB. Use extreme caution, while adjusting the Auxiliary PCB volume control, to prevent the hazard of electrical shock.

#### CAUTION

The heat sink on the Auxiliary PCB gets quite hot when the game is turned on. Use caution, while adjusting the Auxiliary PCB volume control, to prevent burning your hand on this heat sink.

To adjust the game volume, first rotate the volume control, mounted inside the cabinet above and to the right of the game speaker, to its mid position. Then adjust the potentiometer on the Auxiliary PCB for maximum volume without distortion. All volume adjustments should now only be done with the control mounted inside the game cabinet.

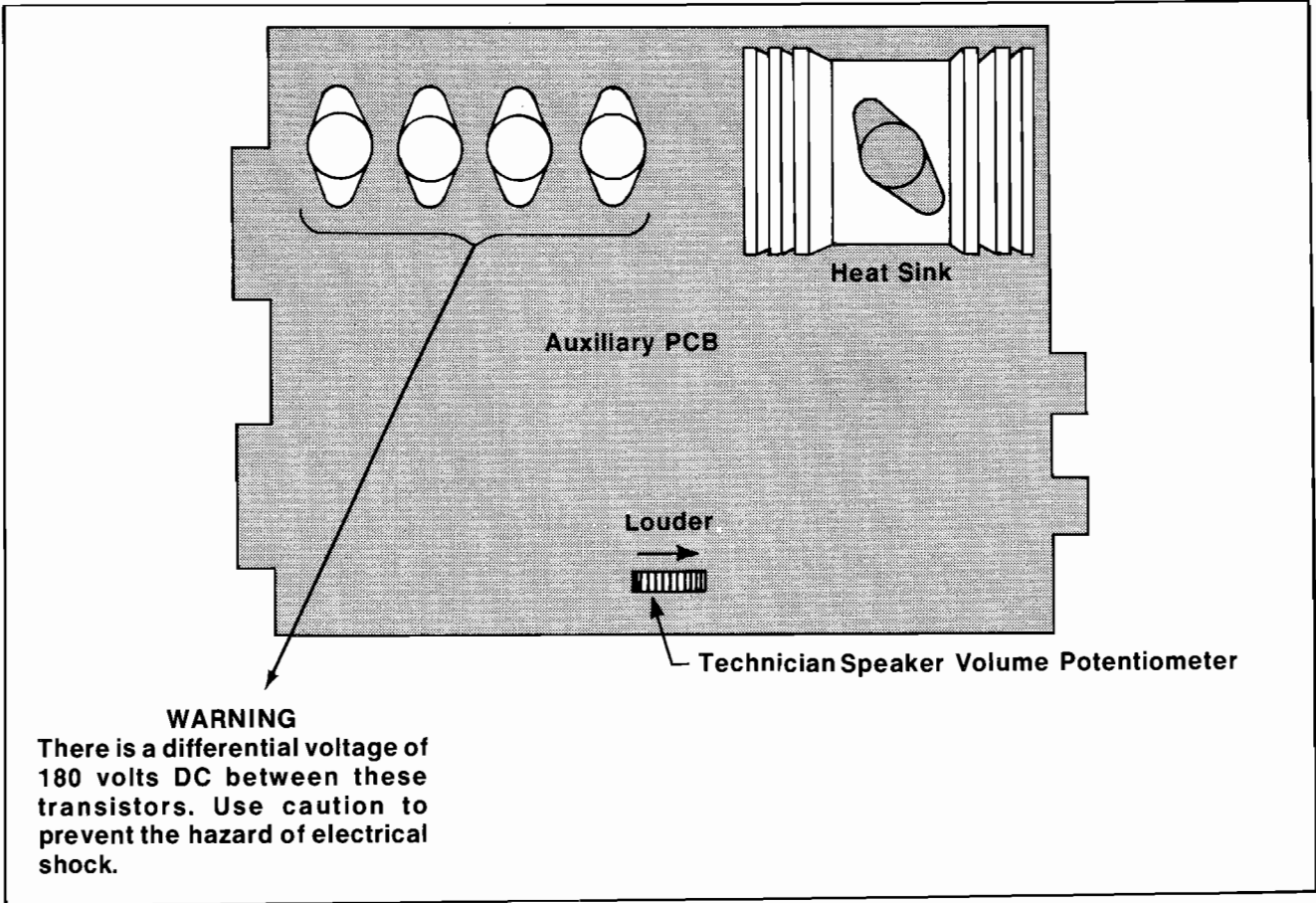
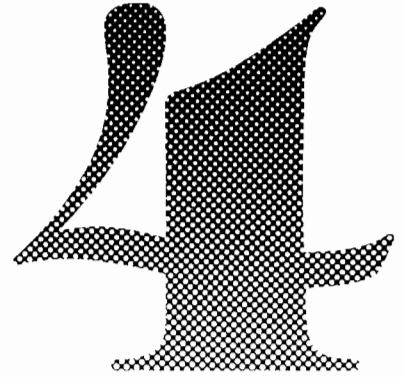
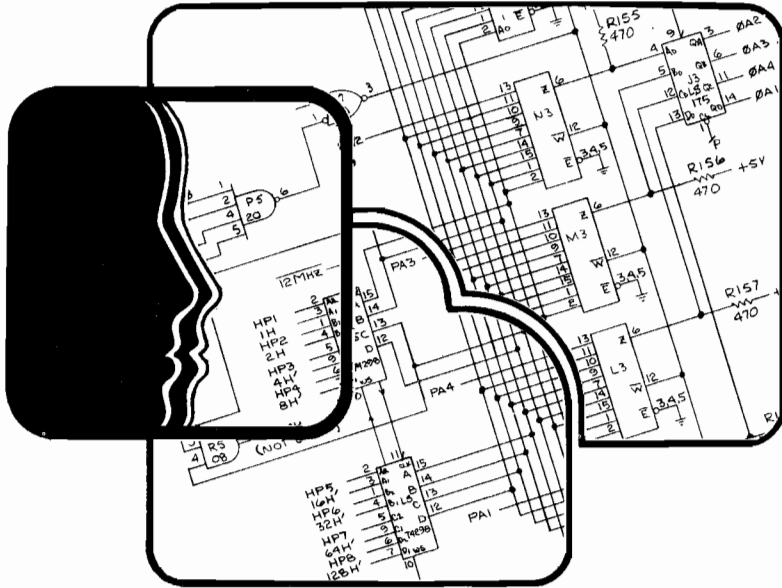

Figure 21 Location of Technician Adjustment for Speaker Volume





# THEORY OF OPERATION

## A. INTRODUCTION

The block diagram in Figure 22 shows the game's major functional elements and depicts their interconnections. The central element is the microcomputer, which consists of a microprocessor, memories and control logic.

By means of a switch sensing circuit, the player-operated switches, playfield switches and operator option switches produce switch data for the microcomputer. Switch closures occur when a player deposits money in the game, depresses the START pushbutton, operates the ball shooter so the ball goes onto the playfield and interacts with playfield objects, and depresses the flipper buttons. Switch closures also result when a player tilts the game. Executing the instructions stored in the pre-programmed portion of its memory, the microcomputer then responds to the switch data by energizing various solenoids, lighting various lamps, and producing sound data for the speaker and display data for the Score, Credit and Ball/Match Displays.

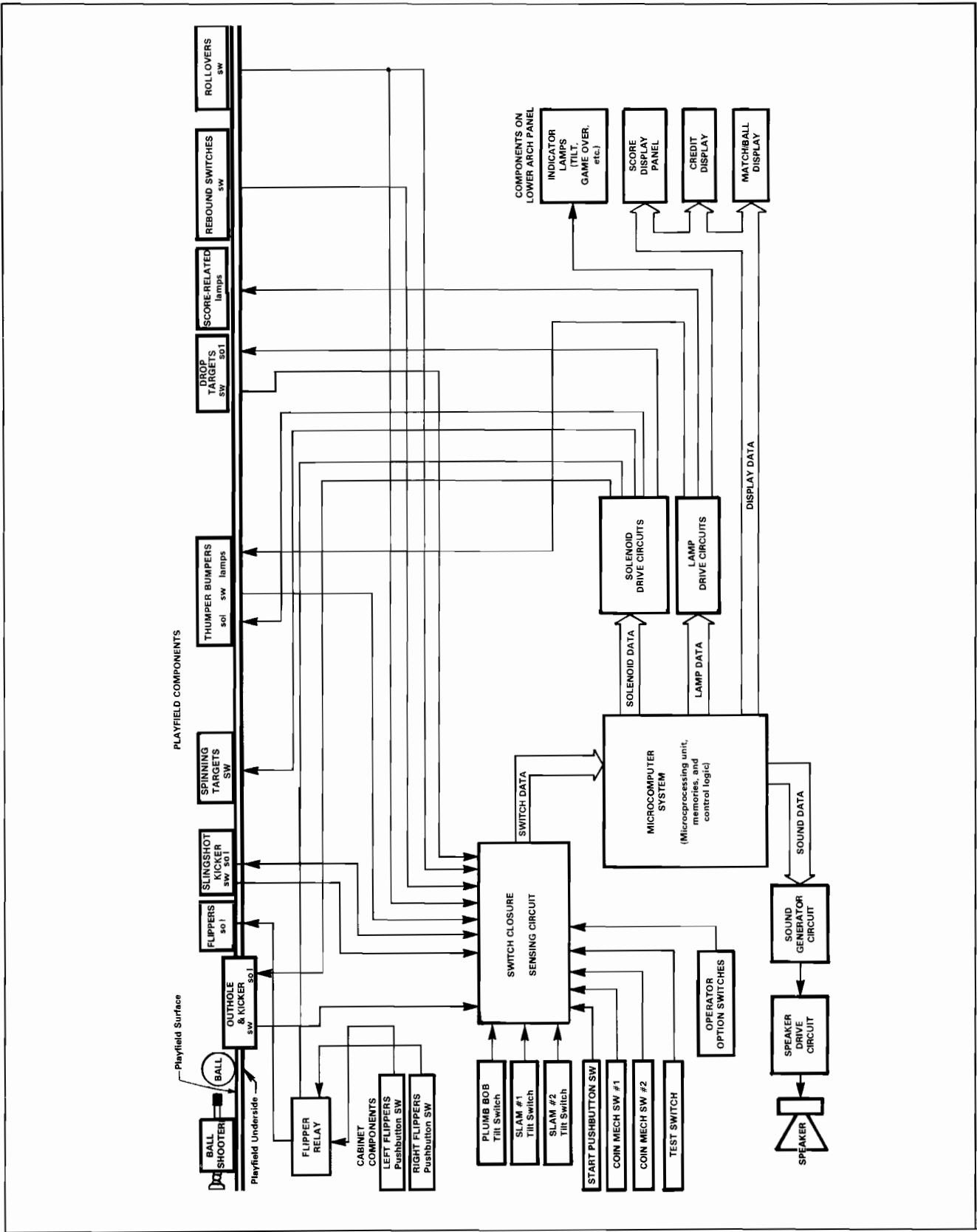

Figure 24 Functional Block Diagram

## **B. COMPONENTS OF THE MICROCOMPUTER SYSTEM**

The microcomputer system carries out complex tasks of the game by performing a large number of simple tasks. Figure 23 shows a block diagram of the microcomputer system and its various interconnecting data, addressing and control buses. The Microprocessing Unit causes the system to perform the desired operations by addressing the Program Memory for an instruction (via the Address Bus), reading that instruction (via the bidirectional Data Bus), and then executing the simple task dictated by that instruction. The Microprocessing Unit uses the Data Memory for temporary storage of data necessary for the execution of future instructions, such as arithmetic operations. The Microprocessing Unit uses the Memory Output Latches for storing the data that is used for producing game sounds, energizing solenoids and lighting lamps.

The following paragraphs describe the game's microcomputer system in more detail. The drawing references are to the Processor PCB schematic shown in Figures 25 and 26.

On the schematic the symbol *P* (which appears at various inputs to logic gates and other integrated circuits) indicates a connection to +5 volts through a pull-up resistor.

As an aid for locating integrated circuit devices referred to in the schematics and assembly drawings, and on the boards themselves, each IC position is given a letter/number designation. On the PCB the IC devices are arranged in columns (along the short dimension of the board) and rows (along the long dimension). The letter refers to a column, and the number refers to a row.

Thus, for example, the type-9321 IC device given the designation D1 and drawn near the center of sheet 1 is found as the second device in the "D" row of devices mounted on that board.

### **Microprocessing Unit**

The large block drawn along the left side of sheet 1 of the schematic represents the Microprocessing Unit. The signal names for the various Data Bus, Address Bus and Processor Controls are labeled inside the block.

### **Program Memory**

Eight ROM devices in locations E1 through E8 for the -11, -14, and -16 PCBs and two ROM devices in

locations E00 and E0 for the -15 PCB form the program memory. Note that the address inputs of all ROMs are connected in parallel and are tied to the A0B through A9B signals. These signals are produced by buffer logic connected to the Microprocessing Unit's Address Bus (signals A0 through A9). Also note that all CE2 inputs (pin 10) are tied together and driven by a common signal, and that the CE1 inputs are driven by signals derived from A10 and A11 produced by the Microprocessing Unit. All ROM data terminals are connected in parallel to the Data Bus (D0 through D7).

Although all eight devices are ROMs, they should never be interchanged (that is, E1 unplugged and plugged into the E2 position, and vice versa), because different data has been programmed in each ROM.

Inside each ROM the data is organized in a 1K x 4 format (1024 bits by 4), giving each ROM a capacity of 4096 data bits.

### **Data Memory**

The four devices in locations D5 through D8 form the Data Memory. Note that all address inputs are connected in parallel (together with the ROMs) to the A0B through A9B signals, and that all RAM data terminals are connected in parallel (together with the ROMs) to the Data Bus. The Microprocessing Unit's R/W bus control signal is buffered and then connected to all RAM R/W inputs.

### **Memory Output Latches**

The eight type-9334 devices along the right side of the sheet form the Memory Output Latches. The addressing signals applied to each latch (at pins 1, 2, and 3) are derived from the A2, A3, and A7 Address Bus signals. One Data Bus bit is applied to each latch device (for example, Bit D0 is applied to the latch in location C20, Bit D1 to C19, and so forth). The  $\overline{\text{REG LD}}$  (Register Load) signal, produced by the Control Logic, is applied to the  $\overline{\text{E}}$  (Enable not) input of every latch device (at pin 14).

Each latch device has eight outputs, giving a total of 64 LATCH signals. Twelve of these (the signals LATCH 1080 BIT 0 through 4, LATCH 1084 BIT 0 through 4, and Latch 1084 BIT 0 through 4), provide the Sound Data, 32 provide the Lamp Data, and the remaining 20 provide the Solenoid Data.

### **Clock Generator**

The circuit is shown along the bottom of the sheet. The basic frequency source is a 4-MHz crystal-controlled oscillator. Its output is then shaped, di-

vided down, and buffered to produce the  $\overline{\Phi 1}$  and  $\overline{\Phi 2}$  signals (phase 1 not and phase 2 not). These are the non-overlapping, non-symmetrical square wave complements required by the Microprocessing Unit. They are also used in the Control Logic.

### Tri-State Buffers

The two type-8097 devices in locations C4 and C5 on sheet 2 connect Switch Data, display address information, and other Control Logic signals to bits D6 and D7 of the Data Bus, and to Bits A0 through A5 and A12 through A14 of the Address Bus. Keep in mind that these are Tri-State devices. When its control line is in the disable state, a tri-state device's data connections become a high impedance, the equivalent of removing the device from the circuit. But when the control line is in the enable state, the device's data connections are capable of having normal high and low ("1" and "0") levels.

### Control Logic

The portion of the Control Logic that produces the  $\overline{\text{RESET}}$  signal for the Microprocessing Unit is shown at the top of sheet 2. The five type-7493 Counter devices form a single, simple binary counter configuration that is driven by the phase 1 clock signal. The AUDIO CLOCK signal produced by the first 7493 device (at A6 pin 8) is used in the Sound Generator circuit.

If, at any time after power is applied to the game, the count advances far enough to bring the last stage high (A10 pin 9 high), then the  $\overline{\text{RESET}}$  signal will be brought low. ( $\overline{\text{RESET}}$  can also be brought low by manually depressing the  $\overline{\text{RESET}}$  pushbutton mounted on the surface of the Processor PCB.)  $\overline{\text{RESET}}$  going low causes the Microprocessing Unit to begin the restart sequence. The execution of a routine to initialize the processor from its reset condition will be started.

In normal game operation the  $\overline{\text{RESET}}$  signal stays low. The WAKE-UP  $\overline{\text{RESET}}$  signal (applied at pins 2 and 3 of both A9 and A10) periodically goes high, preventing the last counter stages from going high. If some abnormal circumstance occurs, such as a momentary interruption in game power caused by severe transients on the AC power line, then the program sequence inside the Microprocessing Unit may be disrupted and the WAKE-UP  $\overline{\text{RESET}}$  signal may remain low for longer than 100 milliseconds. In such a case, a high-to-low-level transition (positive-going edge) on the  $\overline{\text{RESET}}$  signal is produced, and the microcomputer system resets itself.

Other portions of the Control Logic are covered under the Circuit Descriptions that follow.

## C. CIRCUIT DESCRIPTIONS

### Solenoid Driver Circuits

Twenty of the outputs from the Memory Output Latches constitute the Solenoid Data shown in Figure 23. These are the signals LATCH 1080 BIT 4 through 7, LATCH 1084 BIT 4 through 7, LATCH 1088 BIT 4 through 7, and LATCH 108C BIT 0 through 7 (shown on sheet 1 of Processor PCB schematic).

Two of these signals, LATCH 1080 BIT 4 and 5, connect to the Auxiliary PCB where they each drive a type-7407 Inverter followed by a 2N6044 Darling-ton-connected transistor pair. The remaining eighteen LATCH signals connect to the same types of devices (7404 and 2N6044) on the Processor PCB.

Figure 30 shows a simplified diagram of the basic solenoid drive circuit for all solenoids. One side of the solenoid coils connects to the collectors of the 2N6044 transistors; the other side is brought, together with all the other coils, to an unregulated, full-wave rectified DC power supply of about 35 volts amplitude. This power supply is located in the Power Supply Assembly in the right rear corner of the cabinet. Note that a suppression diode is placed across each coil; the diode protects the 2N6044 from reverse inductive kickback (back emf) when the coil is de-energized. The emitters of all 2N6044 devices and the ground side of the 35-volt supply are returned to SOLENOID GRD (at J9, pin 3).

Remember that the microcomputer, by means of the PHASE signal, is able to synchronize the turning on of the solenoids so that it will start only at a zero crossing point (zero power point) of the power line waveform.

Drive components for the coin counter metering function are on the Processor PCB. Also provided are signals from the microcomputer and spaces on the board for additional drive components, so that operators wishing to have four additional functions can do so by installing additional components. The four functions, components required, and their circuit designations are listed in Table 15. Figure 31 shows the circuit for each metering function to be added.

### Lamp Driver Circuits

Thirty-two of the outputs from the Memory Output Latches constitute the lamp data shown in Figure 23. These are the BIT 0 through BIT 7 signals LATCH 1000, LATCH 1004, LATCH 1008 and LATCH 100C. All



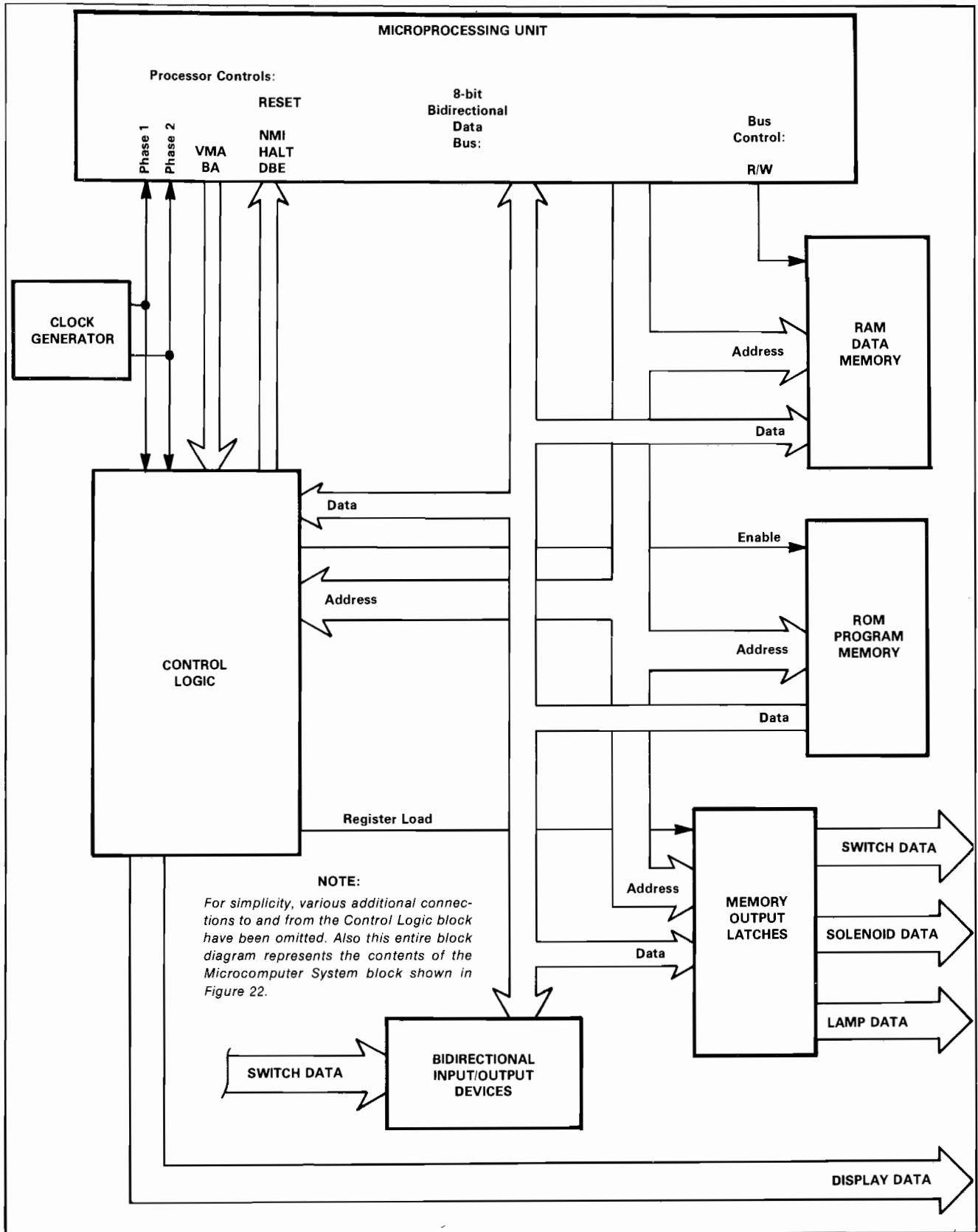
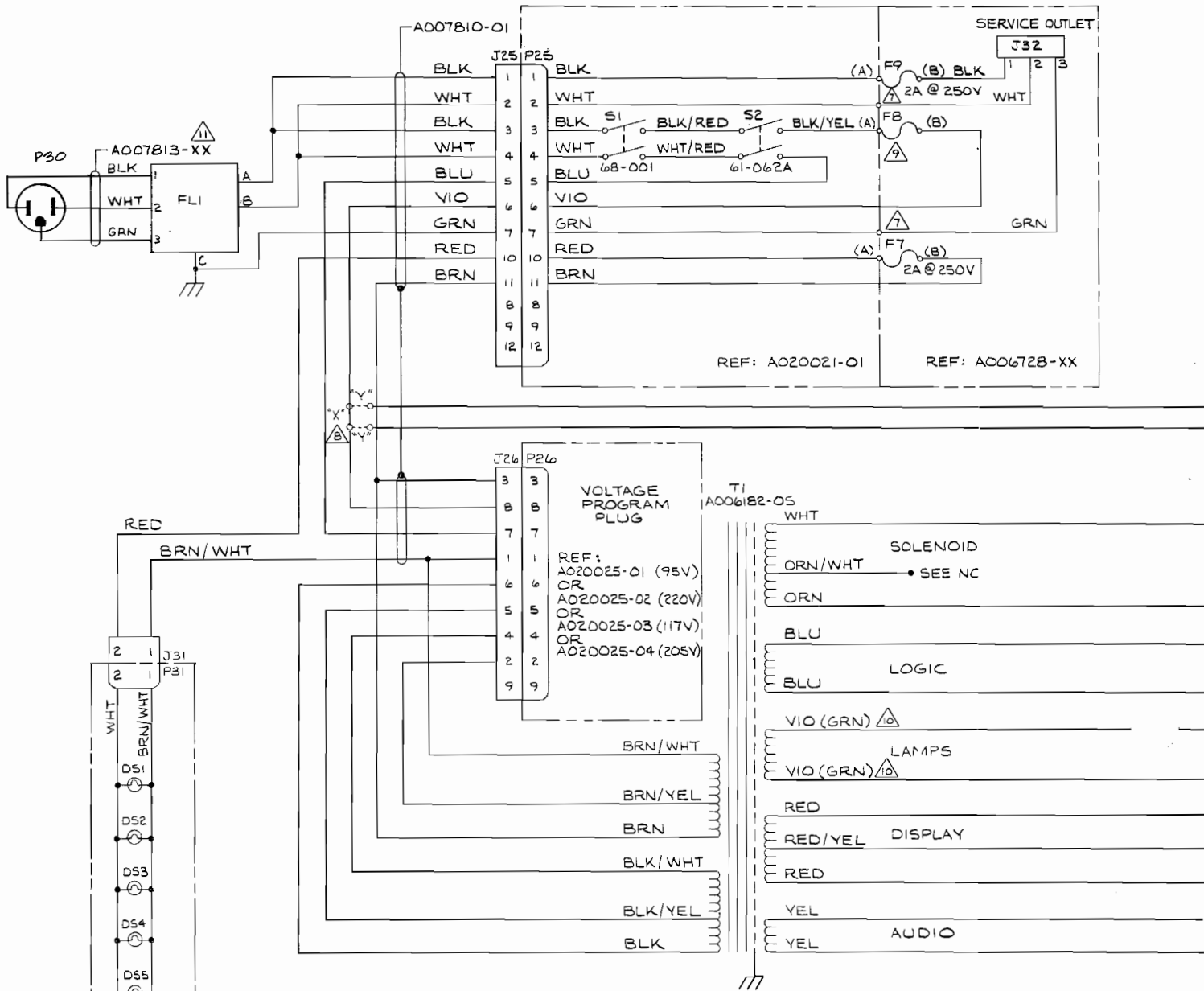

Figure 23 Block Diagram of Microcomputer System



REF: A007867-01

NOTES: (UNLESS OTHERWISE SPECIFIED)

1. \_\_\_\_\_ DENOTES ENCLOSURE OF COMPONENTS EXTERNAL TO POWER SUPPLY A006032-09, -10, -11, -12, -13.

2. ADD KIT A020317-02 ON ALL 205V AND 220V SYSTEMS.

3. LAST DESIGNATIONS USED ARE: C2, CR30, DS84, F9, J41, K22, P41, R17, S66, T1, FLI.

4. REF DESIGNATIONS NOT USED: DS59 P5, 6, 27 THRU 29, 32 AND 34  
 R2, 3, 4, 6, 7, 8, 13 AND 14 K19 AND 20 J5, 6, 27 THRU 30, AND 34  
 CR6, 7, 10, 14 THRU 20 S56 THRU 62

5. USE LINEAR FLIPPER RELAY KIT, A020606-01, FOR ALL 95V AND 117V SYSTEMS. THIS SAME RELAY IS PART OF A020317-02, USED ON 205V AND 220V SYSTEMS.

6. OPTIONAL 35VAC FOR SOLENOID DRIVE.

7. SPLICE TOGETHER AT A006728-XX.

8. "X" WIRING IS FOR 95V & 110V GAMES. "Y" WIRING IS FOR 205V & 220V GAMES.

VOLTS	FUSE	TYPE
95 & 117	FB	7A @ 250V(SLO-BLO)
205 & 220	FB	4A @ 250V (SLO-BLO)

- 10 GRN IS AN OPTIONAL COLOR.
- 11 USE POWER CORD ASSY. A007B13-01 OR -02, FOR DOMESTIC GAMES, A007B13-03 FOR GERMAN GAMES AND A007B13-04 FOR AUSTRALIAN GAMES.
- 12 DIODES ARE 1N4001, EXCEPT CR22 THRU 30, WHICH ARE 1N4005.
- 13 ASSY A020235-01 IS A STANDARD ITEM ON ALL PRODUCTION MACHINES.
- 14 METER BOARD KIT ASSY A020234-01 IS USED ON MACHINES WITH OPTIONS. TO ADD METER BOARD OPTION: REMOVE BLU WIRE FROM P8-B, PIN 19, W AND GRN WIRE FROM P21, PIN 7 IN ASSY A020235-01. ADD ASSY A020234-01 AS SHOWN IN DETAIL 'A', & ADD REQUIRED FUSES AT FUSE BOARD A020307-06.
- 15 P21 CONNECTOR IS NOT PART OF KIT ASSY A020234-01.
- 16 P21 CONNECTOR IS NOT PART OF KIT ASSY A020235-01.

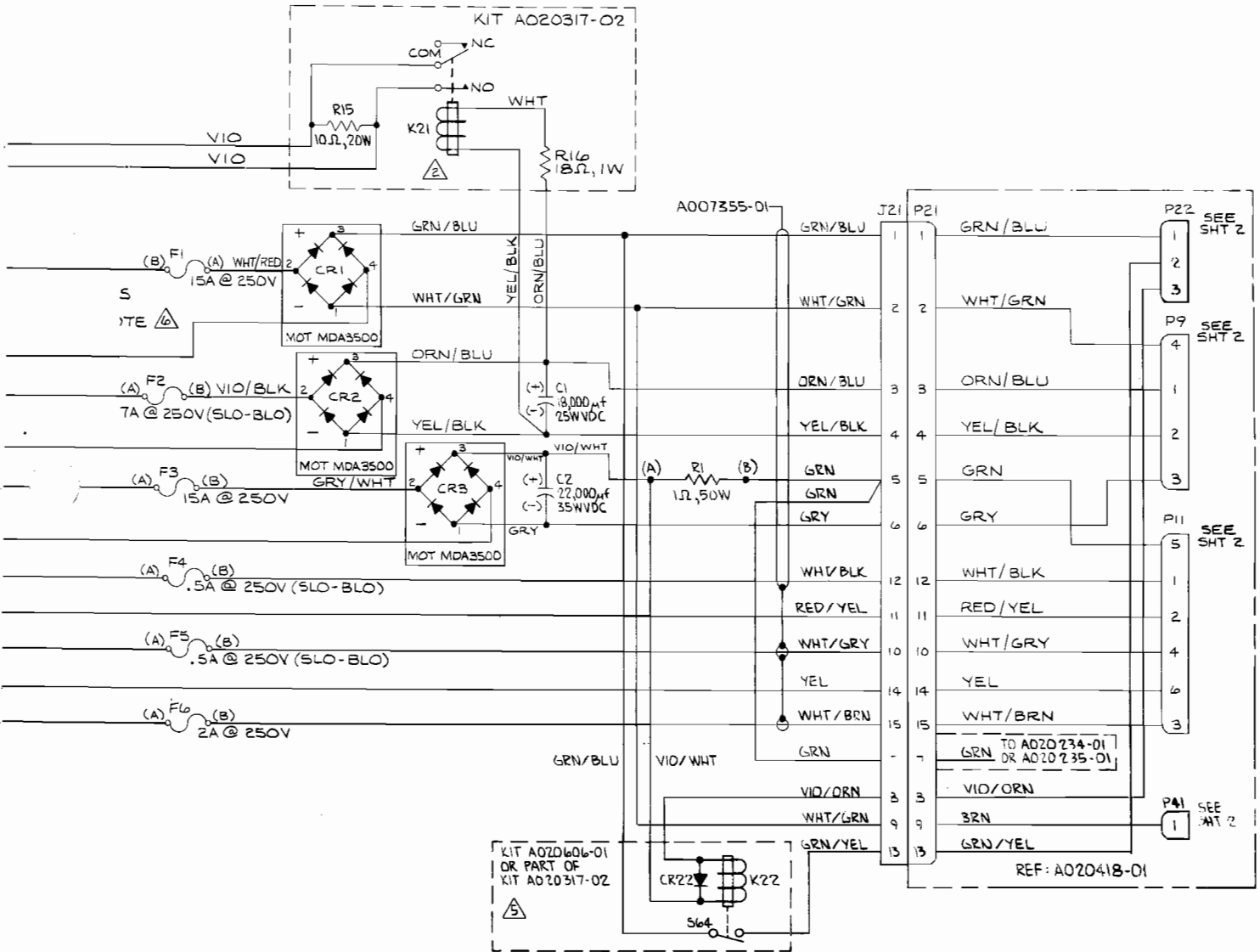

NOTICE TO ALL PERSONS RECEIVING THIS DRAWING  
 CONFIDENTIAL: Reproduction forbidden without the  
 specific written permission of Atari, Inc., Sunnyvale,  
 California. This drawing is only conditionally issued, and  
 neither receipt nor possession thereof confers or transfers  
 any right in, or license to use, the subject matter of the  
 drawing or any design or technical information shown  
 thereon, nor any right to reproduce this drawing or any part  
 thereof, except for manufacture by vendors of Atari, Incor-  
 porated and for manufacture under the corporation's writ-  
 ten license, no right to reproduce this drawing is granted  
 or the subject matter thereof unless by written agreement  
 with or written permission from the corporation.

Figure 24 Middle Earth Wiring Diagram  
 020447 (Sheet 1 of 2)

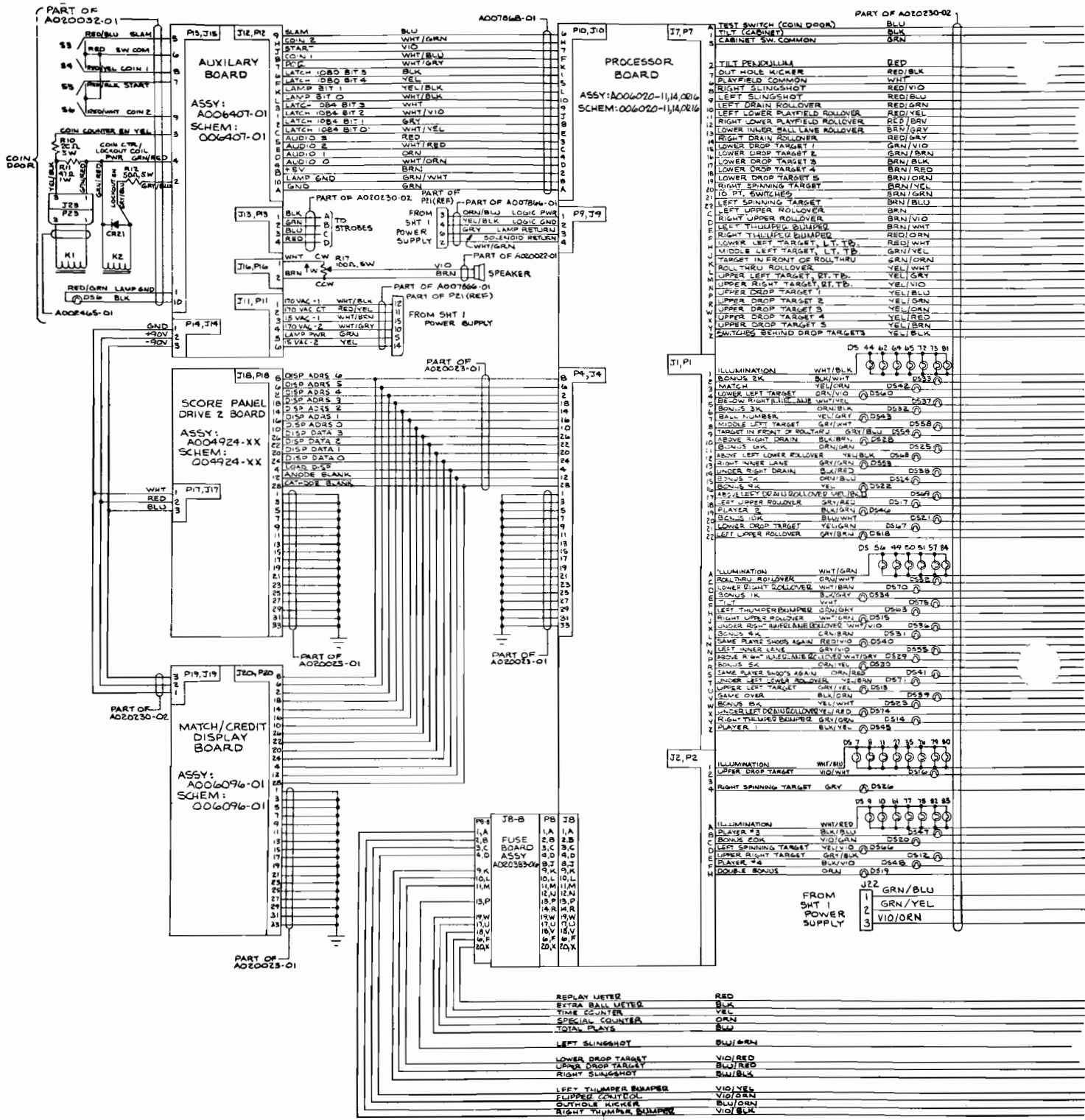

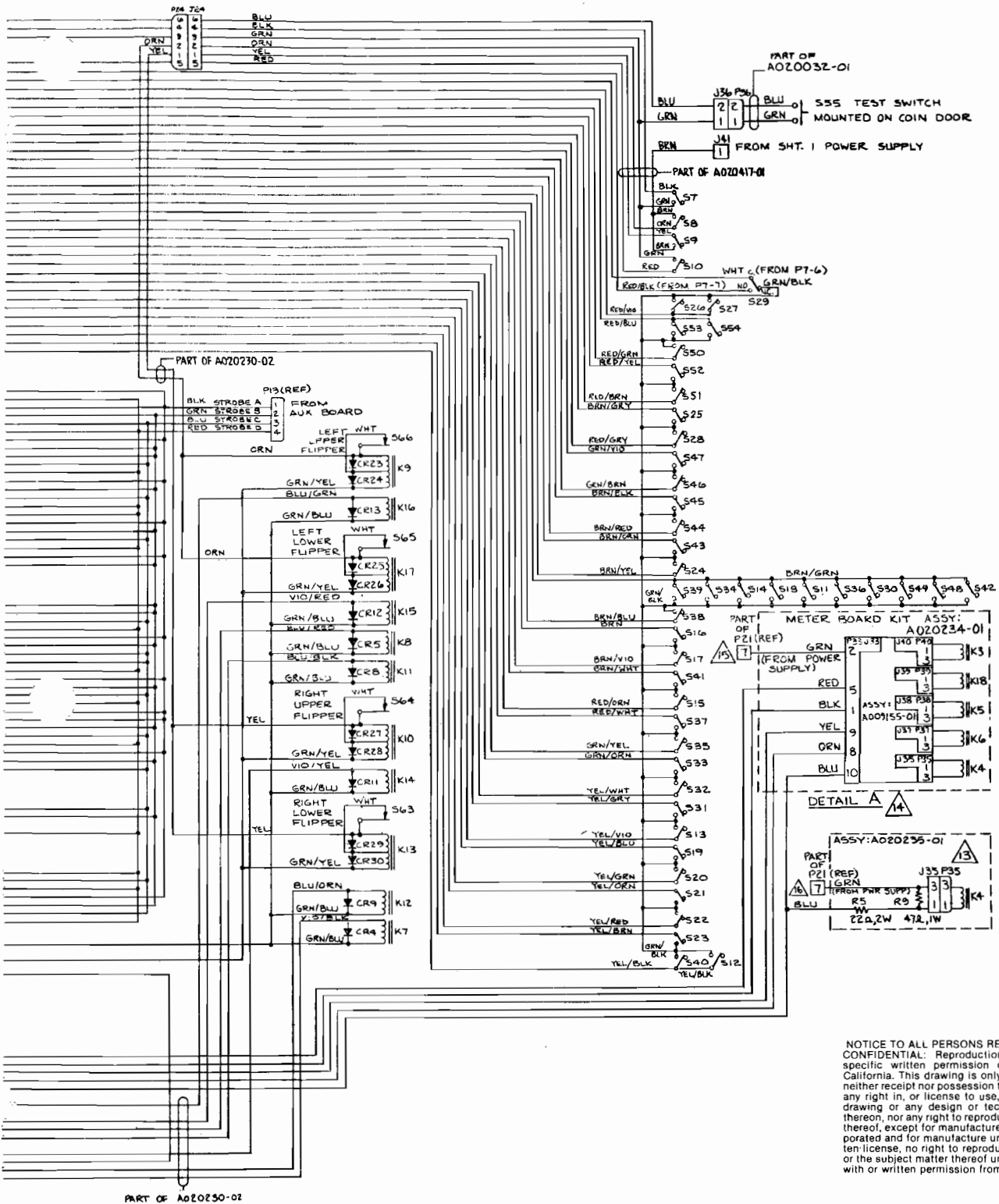

NOTICE TO ALL PERSONS RECEIVING THIS DRAWING  
 CONFIDENTIAL: Reproduction forbidden without the  
 specific written permission of Atari, Inc., Sunnyvale,  
 California. This drawing is only conditionally issued, and  
 neither receipt nor possession thereof confers or transfers  
 any right in, or license to use, the subject matter of the  
 drawing or any design or technical information shown  
 thereon, nor any right to reproduce this drawing or any part  
 thereof, except for manufacture by vendors of Atari, Incor-  
 porated and for manufacture under the corporation's writ-  
 ten license, no right to reproduce this drawing is granted  
 or the subject matter thereof unless by written agreement  
 with or written permission from the corporation.

Figure 24 Middle Earth Wiring Diagram  
 020447 (Sheet 2 of 2)

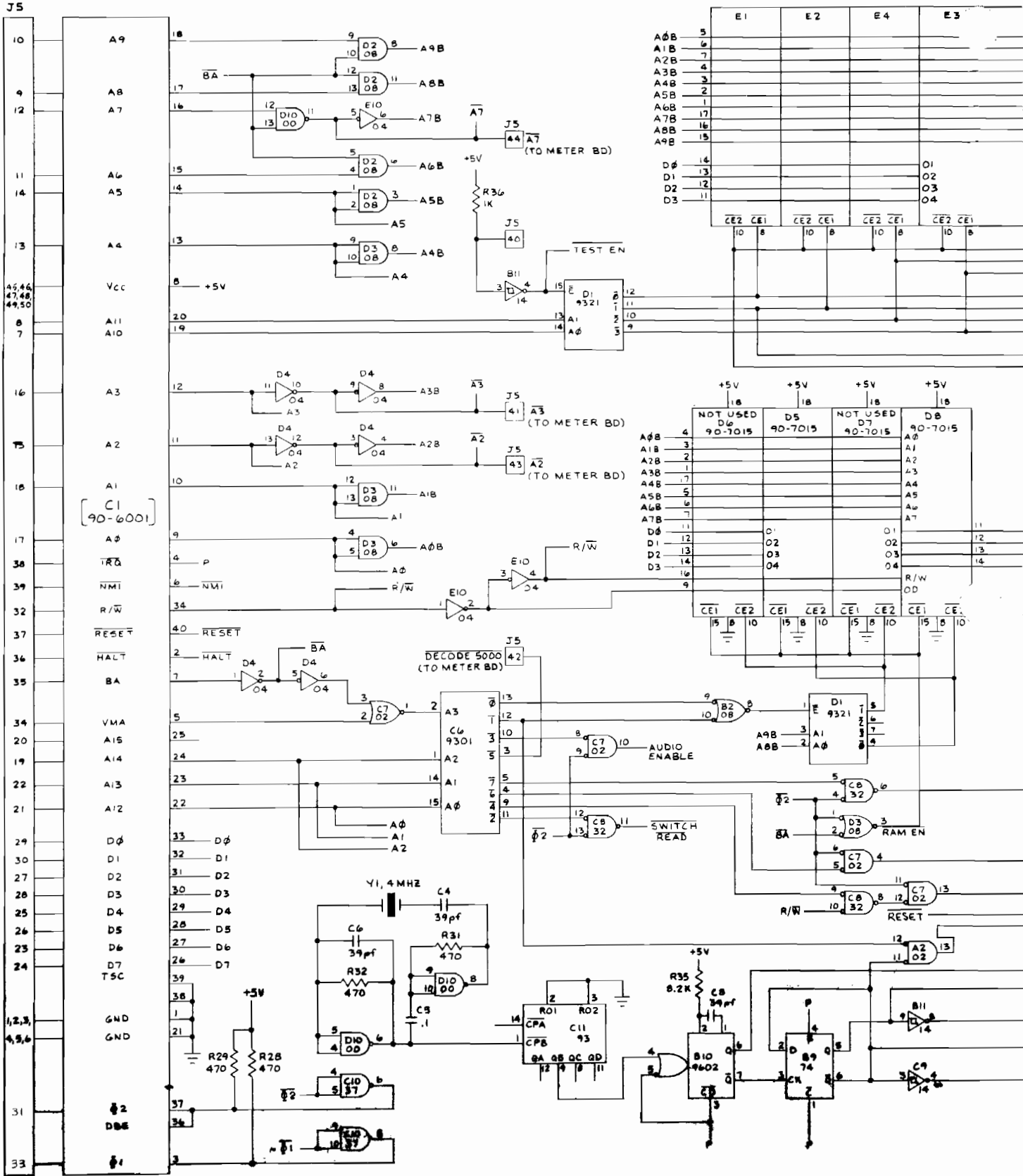

	E1	E2	E4	E3	
A0B	5				
A1B	6				
A2B	7				
A3B	4				
A4B	3				
A5B	2				
A6B	1				
A7B	17				
A8B	16				
A9B	15				
Dφ	14			01	
D1	13			02	
D2	12			03	
D3	11			04	
CE2	CE1	CE2	CE1	CE2	CE1
10	8	10	8	10	8

	D5	D6	D7	D8	
A0B	4				
A1B	3				
A2B	2				
A3B	1				
A4B	7				
A5B	5				
A6B	6				
A7B	11				
Dφ	11			01	
D1	12			02	
D2	13			03	
D3	14			04	
CE1	CE2	CE1	CE2	CE1	CE2
15	8	15	8	15	8

	D5	D6	D7	D8	
A0B	4				
A1B	3				
A2B	2				
A3B	1				
A4B	7				
A5B	5				
A6B	6				
A7B	11				
Dφ	11			01	
D1	12			02	
D2	13			03	
D3	14			04	
CE1	CE2	CE1	CE2	CE1	CE2
15	8	15	8	15	8

SEE CHART FOR PART NO.

VERSION ONLY

VERSION	-11	-14	-16
LOCATION	PART NO.		
E1	020170	020460	020644
E2	020171	020461	020645
E3	020172	020462	020646
E4	020173	020463	020647
E5	020174	020464	020648
E6	020175	020465	020649
E7	020176	020466	020650
E8	020177	020423	020651

-11: STANDARD PROM VERSION  
 -14: GERMAN PROM VERSION  
 -15: LINEAR ROM VERSION  
 -16: LINEAR PROM VERSION

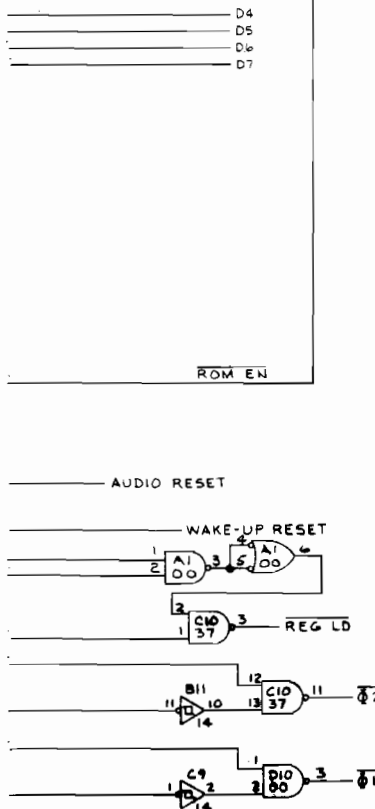
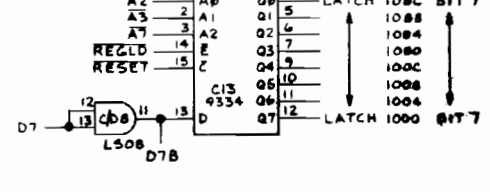
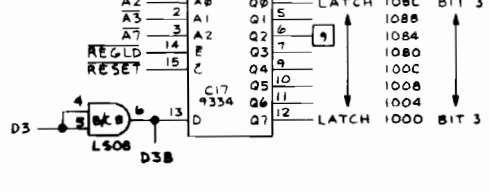
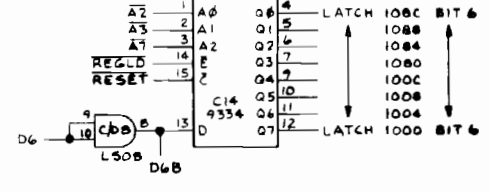
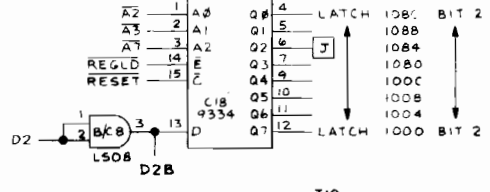
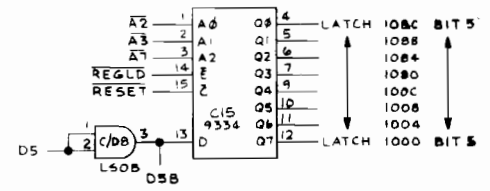
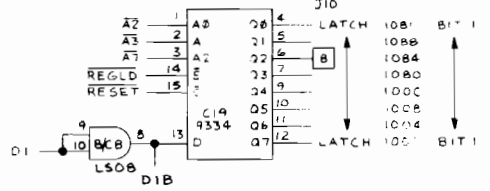
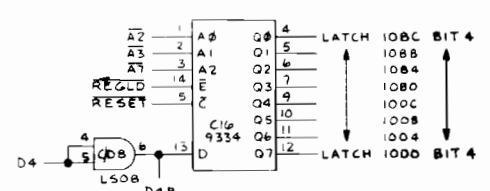
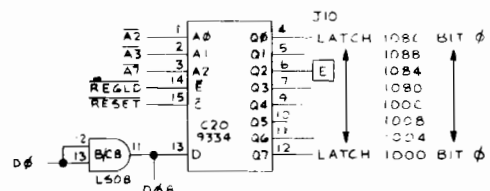
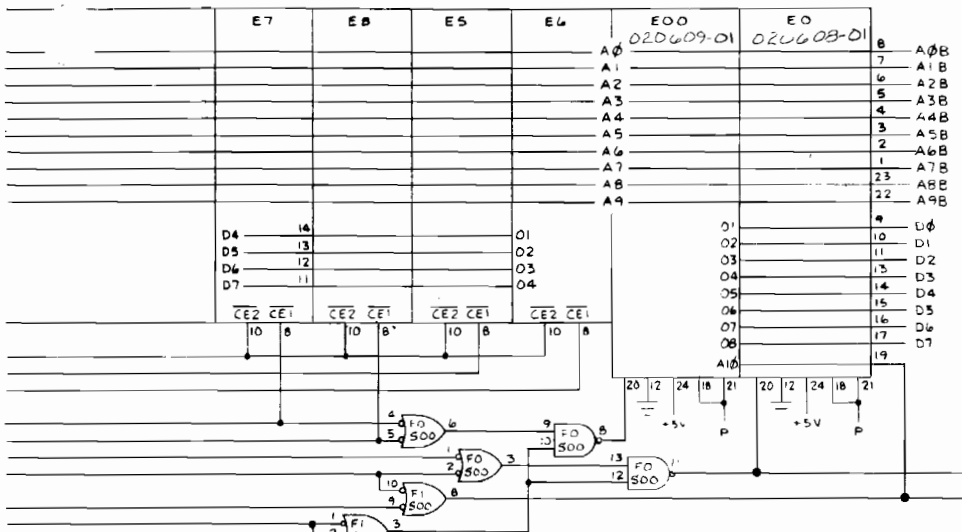

NOTICE TO ALL PERSONS RECEIVING THIS DRAWING  
 CONFIDENTIAL: Reproduction forbidden without the  
 specific written permission of Atari, Inc., Sunnyvale,  
 California. This drawing is only conditionally issued,  
 and neither receipt nor possession thereof confers or transfers  
 any right in, or license to use, the subject matter of the  
 drawing or any design or technical information shown  
 thereon, nor any right to reproduce this drawing or any part  
 thereof, except for manufacture by vendors of Atari, Inc.  
 incorporated and for manufacture under the corporation's written  
 license, no right to reproduce this drawing is granted  
 or the subject matter thereof unless by written agreement  
 with or written permission from the corporation.

**NOTES: UNLESS OTHERWISE SPECIFIED**

1. LAST REF. DES USED: C34, CR20, J10, Q84, R37, Y1.
2. DES. NOT USED: CA17, 18, 20, J3, 14, Q9, 10, 14, 18, 19, R12, 21, 22, 24, 28.

Figure 25 Middle Earth Processor PCB Schematic Diagram 006020-11, -14, -15, and -16 (sheet 1 of 4)

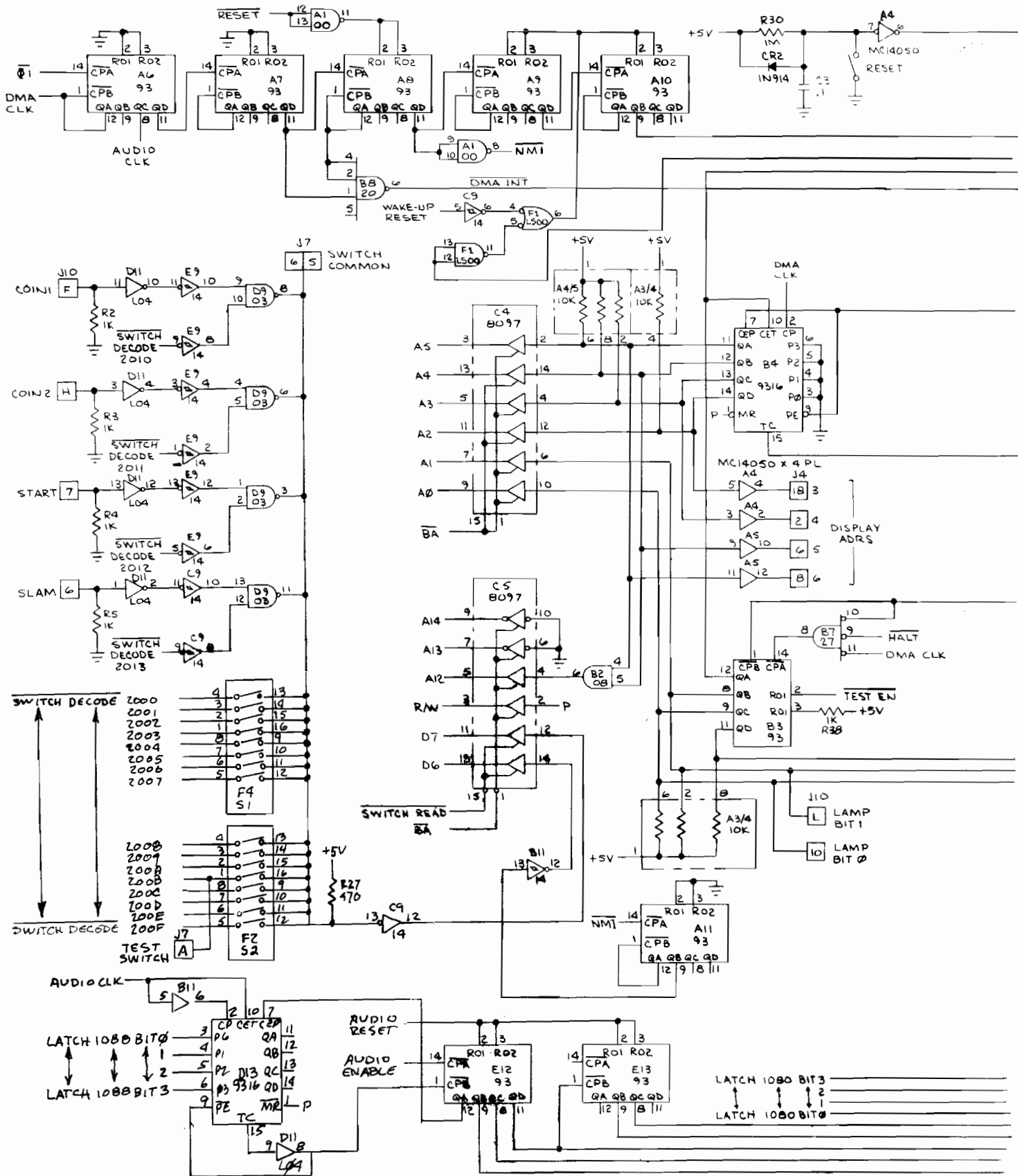



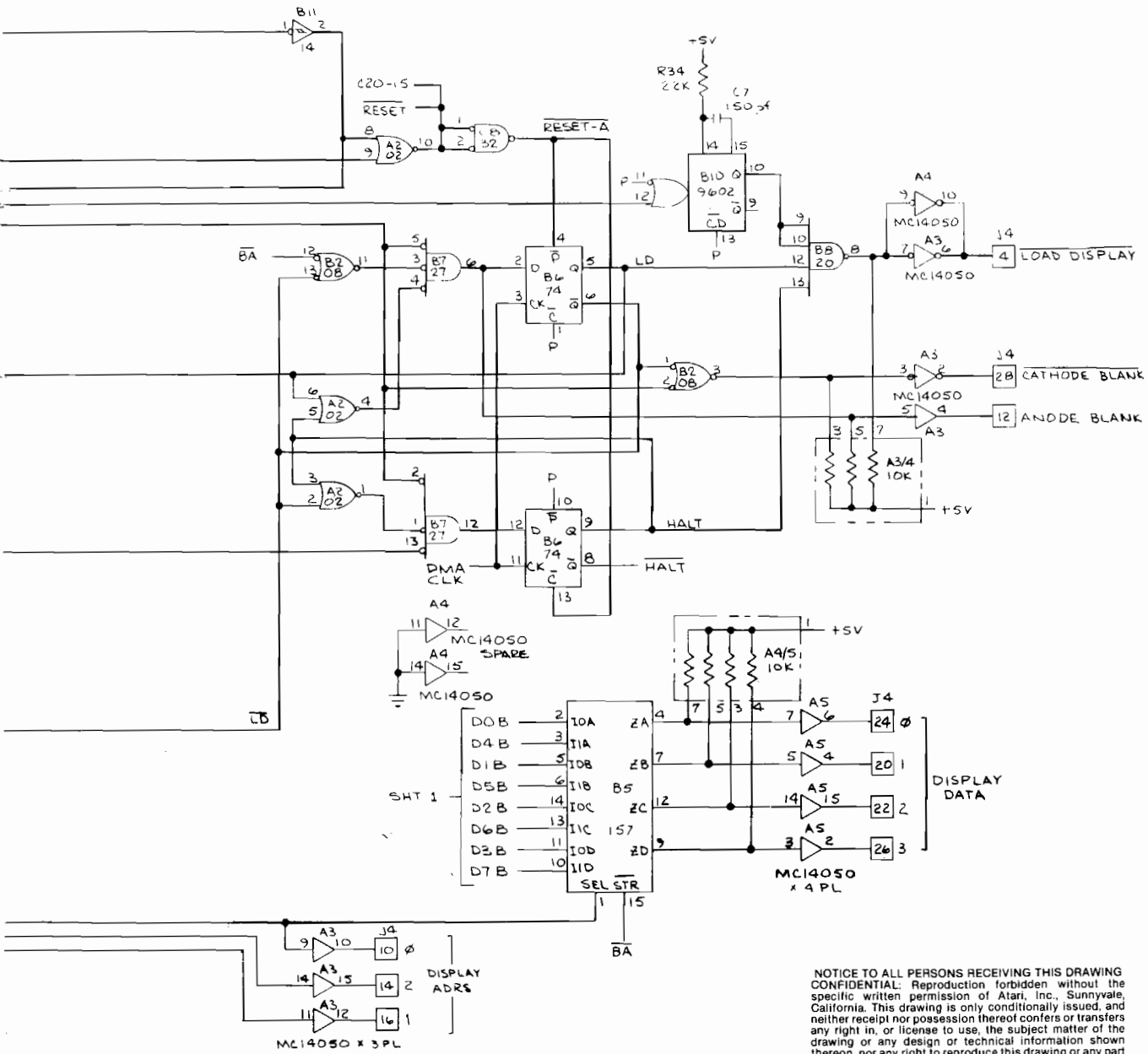

NOTICE TO ALL PERSONS RECEIVING THIS DRAWING  
 CONFIDENTIAL: Reproduction forbidden without the  
 specific written permission of Atari, Inc., Sunnyvale,  
 California. This drawing is only conditionally issued, and  
 neither receipt nor possession thereof confers or transfers  
 any right in, or license to use, the subject matter of the  
 drawing or any design or technical information shown  
 thereon, nor any right to reproduce this drawing or any part  
 thereof, except for manufacture by vendors of Atari, Inc.,  
 incorporated and for manufacture under the corporation's writ-  
 ten license, no right to reproduce this drawing is granted  
 or the subject matter thereof unless by written agreement  
 with or written permission from the corporation.

**NOTE**  
 See Chapter 5, Illustrated Parts Catalog,  
 for values, sizes, and locations of parts on  
 the Processor PCB.

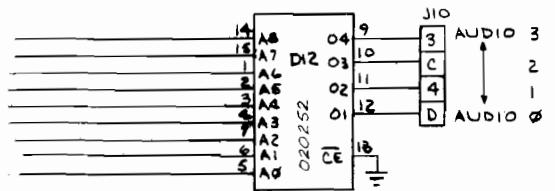
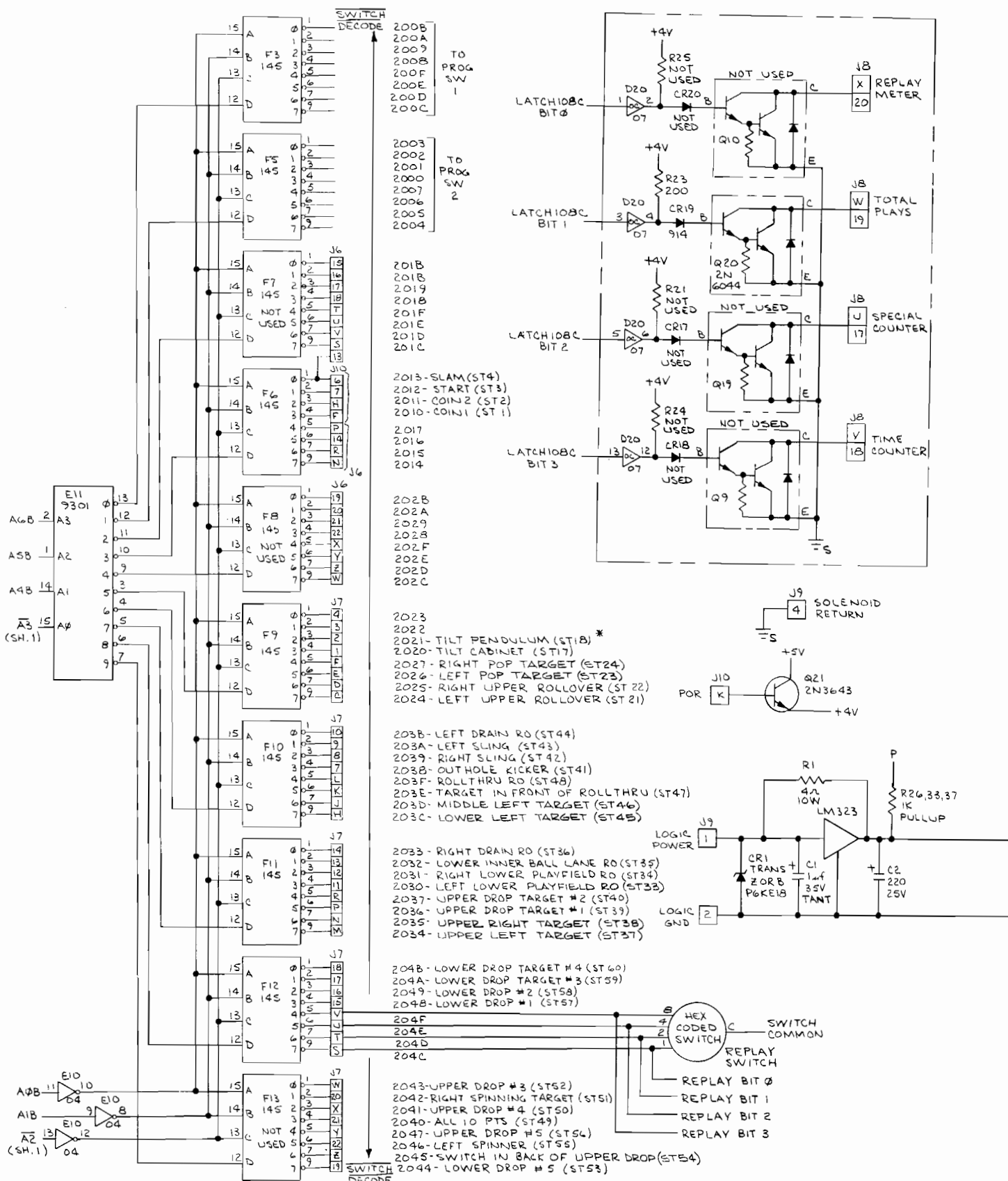

Figure 25 Middle Earth Processor PCB Schematic Diagram  
 006020-11, -14, -15, and -16 (sheet 2 of 4)



200B  
200A  
2009  
2008  
200F  
200E  
200D  
200C

2003  
2002  
2001  
2000  
2007  
2006  
2005  
2004

201B  
2018  
2019  
2018  
201F  
201E  
201D  
201C

2013-SLAM(ST4)  
2012-START(ST3)  
2011-COIN2(ST2)  
2010-COIN1(ST1)

2017  
2016  
2015  
2014

2023  
2022  
2021-TILT PENDULUM(ST18)\*  
2020-TILT CABINET(ST17)  
2027-RIGHT POP TARGET(ST24)  
2026-LEFT POP TARGET(ST23)  
2025-RIGHT UPPER ROLLOVER(ST22)  
2024-LEFT UPPER ROLLOVER(ST21)

203B-LEFT DRAIN RO(ST44)  
203A-LEFT SLING(ST43)  
2039-RIGHT SLING(ST42)  
2038-OUTHOLE KICKER(ST41)  
203F-ROLLTHRU RO(ST48)  
203E-TARGET IN FRONT OF ROLLTHRU(ST47)  
203D-MIDDLE LEFT TARGET(ST46)  
203C-LOWER LEFT TARGET(ST45)

2033-RIGHT DRAIN RO(ST36)  
2032-LOWER INNER BALL LANE RO(ST35)  
2031-RIGHT LOWER PLAYFIELD RO(ST34)  
2030-LEFT LOWER PLAYFIELD RO(ST33)  
2037-UPPER DROP TARGET #2(ST40)  
2036-UPPER DROP TARGET #1(ST39)  
2035-UPPER RIGHT TARGET(ST38)  
2034-UPPER LEFT TARGET(ST37)

204B-LOWER DROP TARGET #4(ST40)  
204A-LOWER DROP TARGET #3(ST39)  
2049-LOWER DROP #2(ST58)  
2048-LOWER DROP #1(ST57)

2043-UPPER DROP #3(ST52)  
2042-RIGHT SPINNING TARGET(ST51)  
2041-UPPER DROP #4(ST50)  
2040-ALL 10 PTS(ST49)  
2047-UPPER DROP #5(ST54)  
2046-LEFT SPINNER(ST55)  
2045-SWITCH IN BACK OF UPPER DROP(ST54)  
2044-LOWER DROP #5(ST53)

\* NOTE  
ST = SWITCH TEST NUMBER

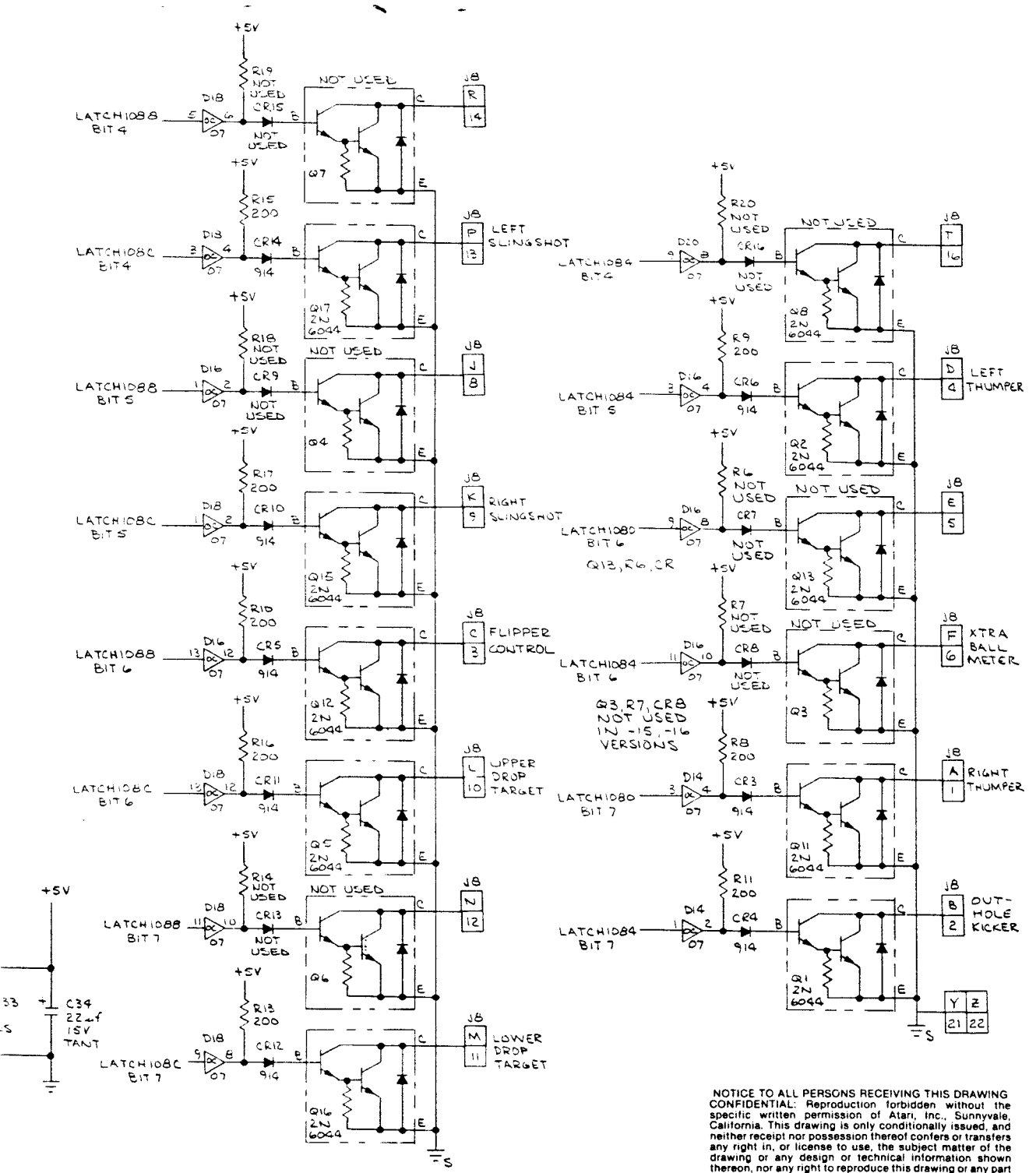

**NOTE**

Chapter 5, Illustrated Parts Catalog, values, sizes, and locations of parts on Processor PCB.

NOTICE TO ALL PERSONS RECEIVING THIS DRAWING CONFIDENTIAL: Reproduction forbidden without the specific written permission of Atari, Inc., Sunnyvale, California. This drawing is only conditionally issued, and neither receipt nor possession thereof confers or transfers any right in, or license to use, the subject matter of the drawing or any design or technical information shown thereon, nor any right to reproduce this drawing or any part thereof, except for manufacture by vendors of Atari, Incorporated and for manufacture under the corporation's written license, no right to reproduce this drawing is granted or the subject matter thereof unless by written agreement with or written permission from the corporation.

Figure 25 Middle Earth Processor PCB Schematic Diagram 006020-11, -14, -15, and -16 (sheet 3 of 4)

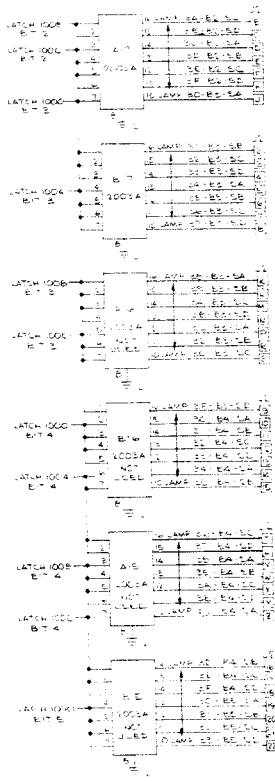
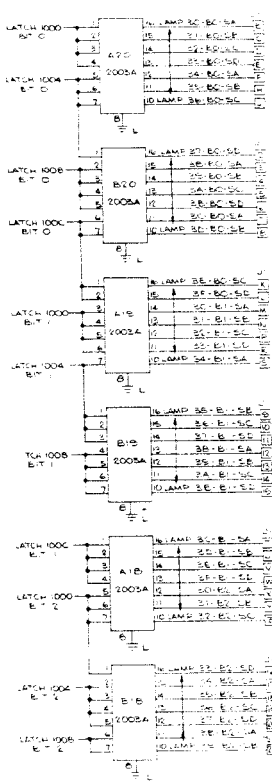

NOTICE TO ALL PERSONS RECEIVING THIS DRAWING  
 CONFIDENTIAL. Reproduction forbidden without the  
 specific written permission of Atari, Inc., Sunnyvale,  
 California. This drawing is only conditionally issued and  
 neither receipt nor possession on the part of centers or registrars  
 entitles them or their licensees to use the subject matter of the  
 drawing or any design or technical information shown  
 thereon, nor any right to reproduce this drawing or any part  
 thereof, except for manufacture by vendors of Atari, incor-  
 porated and for manufacture under the corporation's writ-  
 ten license; no right to reproduce this drawing is granted  
 of the subject matter thereon unless by written agreement  
 with or written permission from the corporation.

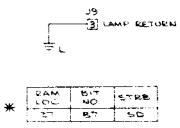
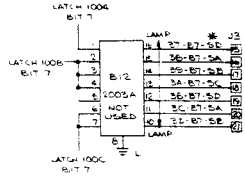
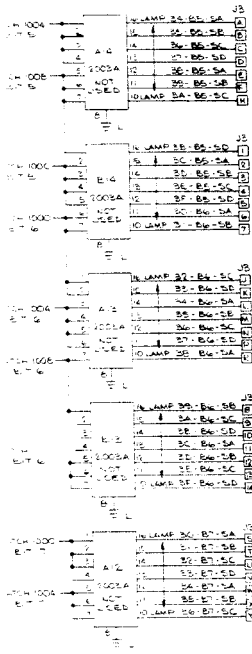

LAMP	BIT	STRIP
37	27	5D

**NOTE**  
 Chapter 5, Illustrated Parts Catalog, lists part numbers, sizes, and locations of parts on processor PCB.

Figure 25 Middle Earth Processor PCB Schematic Diagram 006020-11, -14, -15, and -16 (sheet 4 of 4)

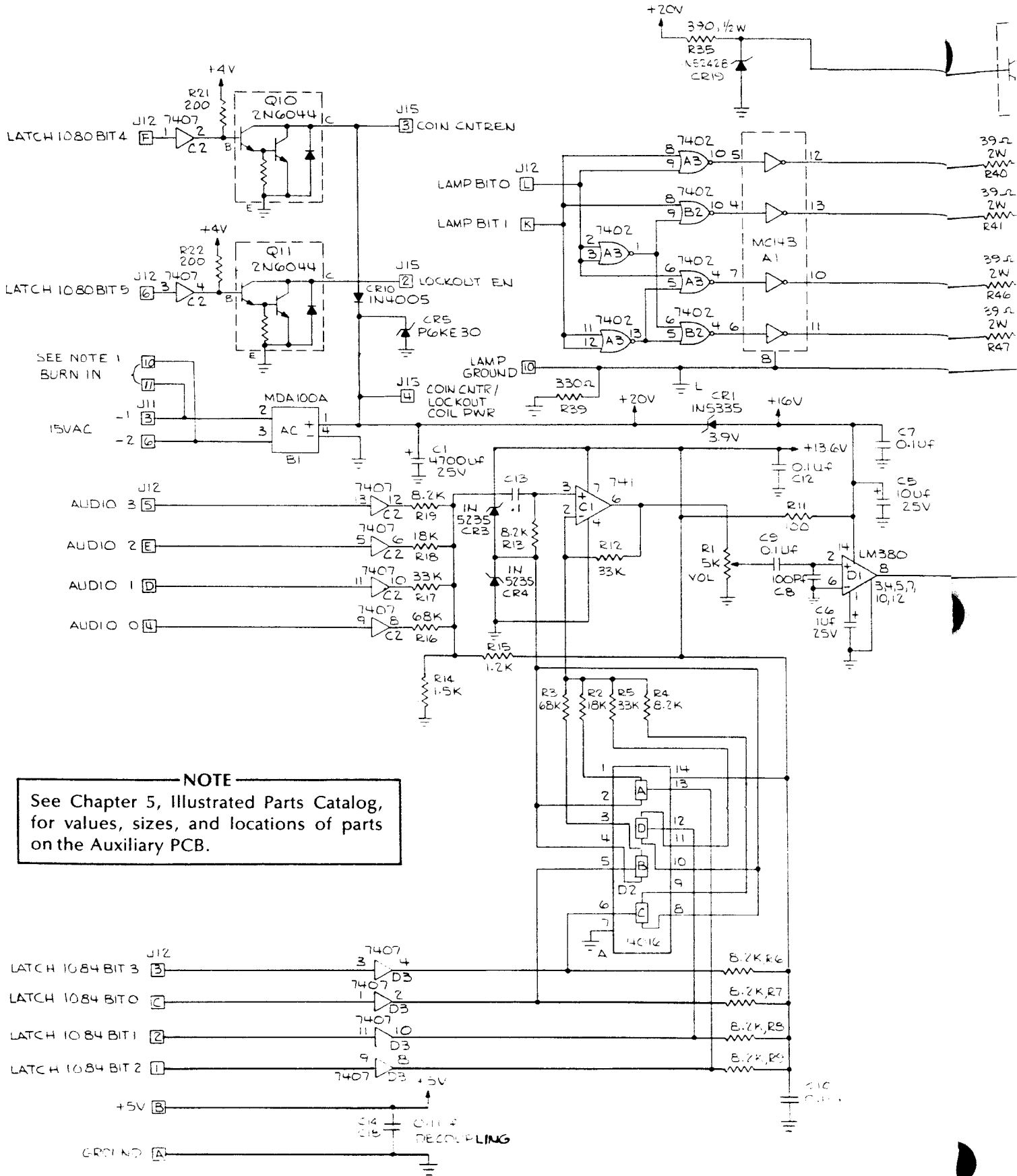

**NOTE**  
 See Chapter 5, Illustrated Parts Catalog,  
 for values, sizes, and locations of parts  
 on the Auxiliary PCB.

NOTICE TO ALL PERSONS RECEIVING THIS DRAWING  
 CONFIDENTIAL: Reproduction forbidden without the  
 specific written permission of Atari, Inc., Sunnyvale,  
 California. This drawing is only conditionally issued,  
 and neither receipt nor possession thereof confers or transfers  
 any right in, or license to use, the subject matter of the  
 drawing or any design or technical information shown  
 thereon, nor any right to reproduce this drawing or any part  
 thereof, except for manufacture by vendors of Atari, Inc.,  
 incorporated and for manufacture under the corporation's writ-  
 ten license. No right to reproduce this drawing is granted  
 or the subject matter thereof unless by written agreement  
 with or written permission from the corporation.

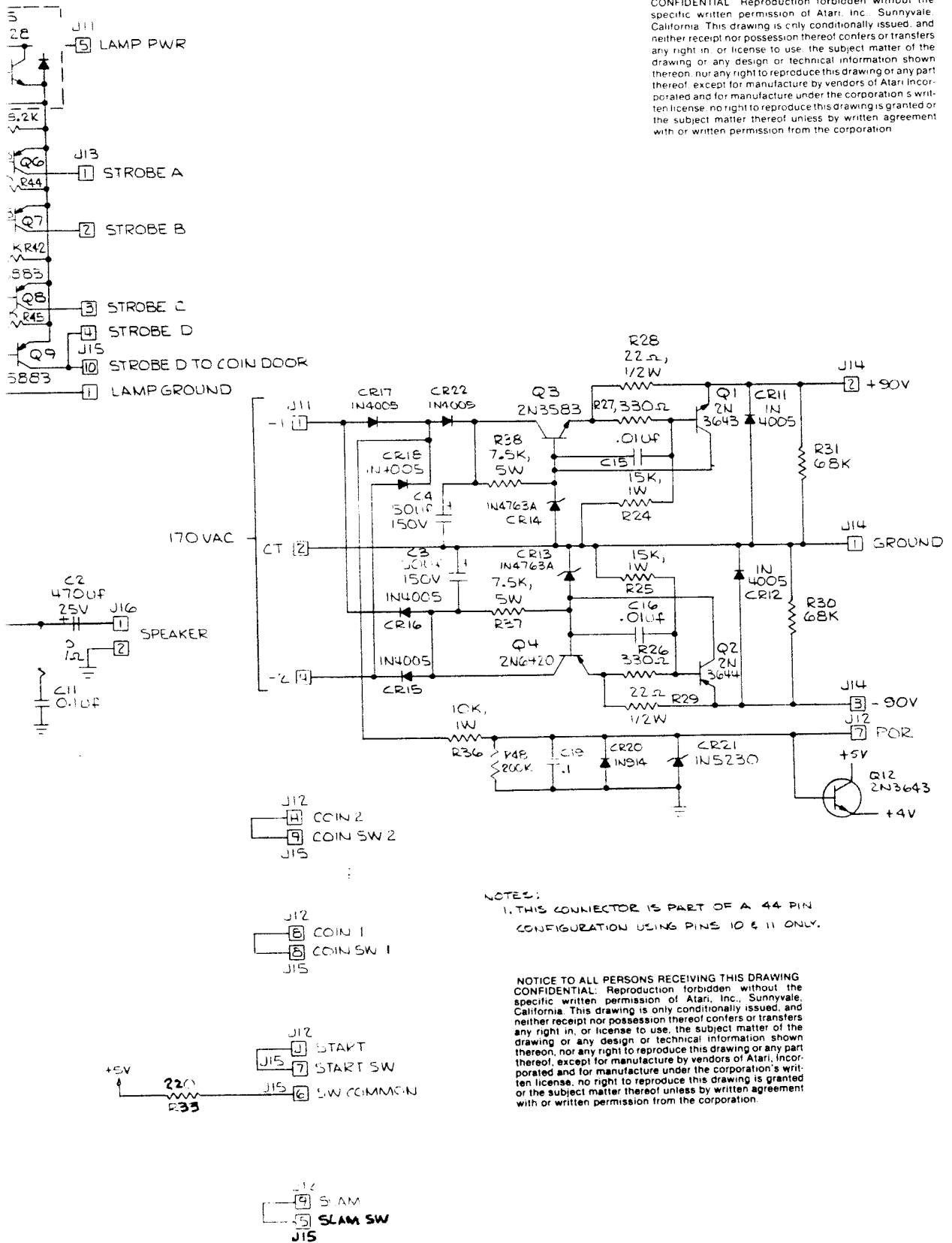

NOTES:  
 1. THIS CONNECTOR IS PART OF A 44 PIN  
 CONFIGURATION USING PINS 10 & 11 ONLY.

NOTICE TO ALL PERSONS RECEIVING THIS DRAWING  
 CONFIDENTIAL: Reproduction forbidden without the  
 specific written permission of Atari, Inc., Sunnyvale,  
 California. This drawing is only conditionally issued,  
 and neither receipt nor possession thereof confers or transfers  
 any right in, or license to use, the subject matter of the  
 drawing or any design or technical information shown  
 thereon, nor any right to reproduce this drawing or any part  
 thereof, except for manufacture by vendors of Atari, Inc.,  
 incorporated and for manufacture under the corporation's writ-  
 ten license. No right to reproduce this drawing is granted  
 or the subject matter thereof unless by written agreement  
 with or written permission from the corporation.

Figure 26 Auxiliary PCB Schematic Diagram  
 006407-01

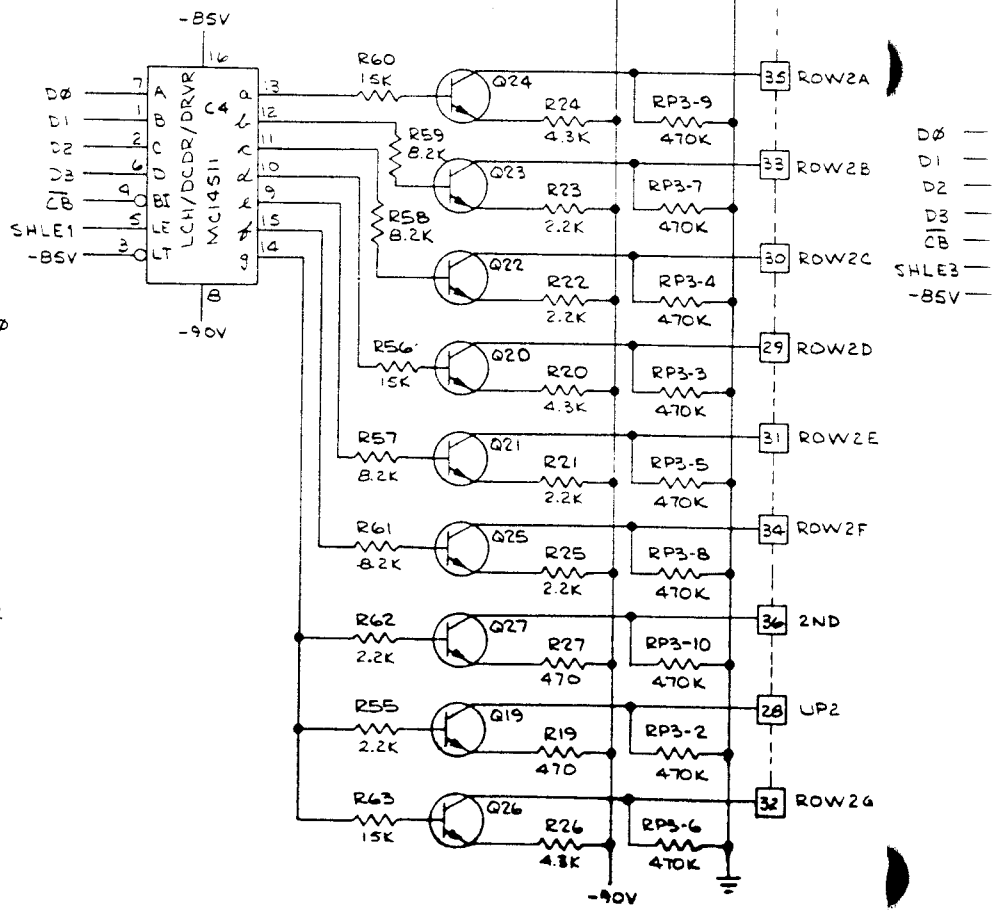
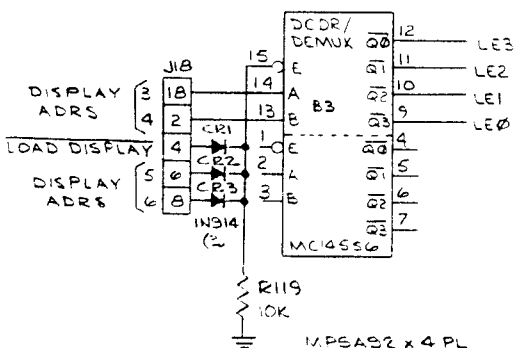
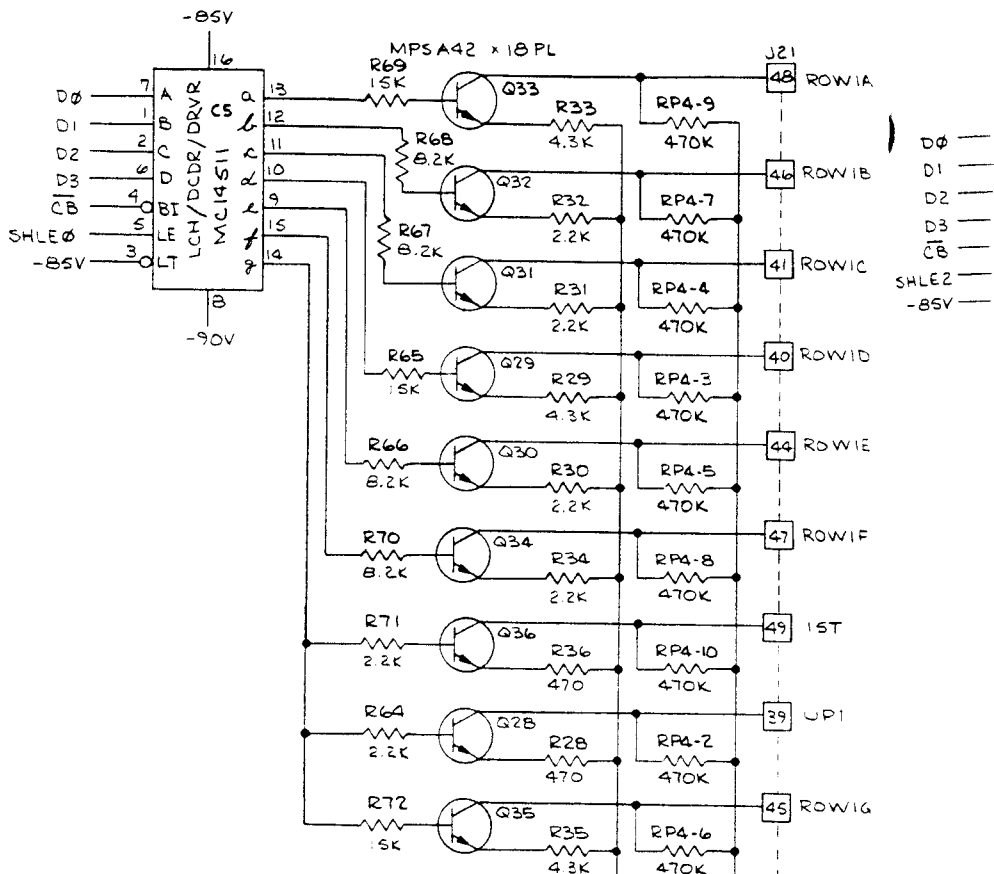
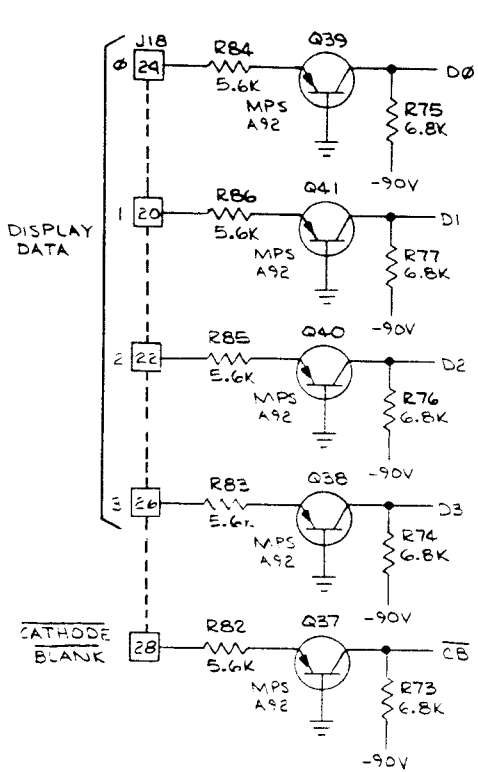



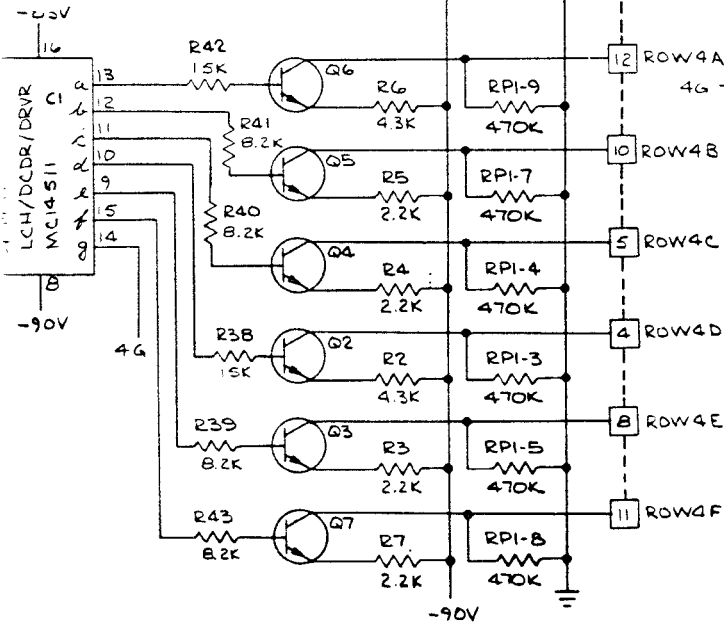
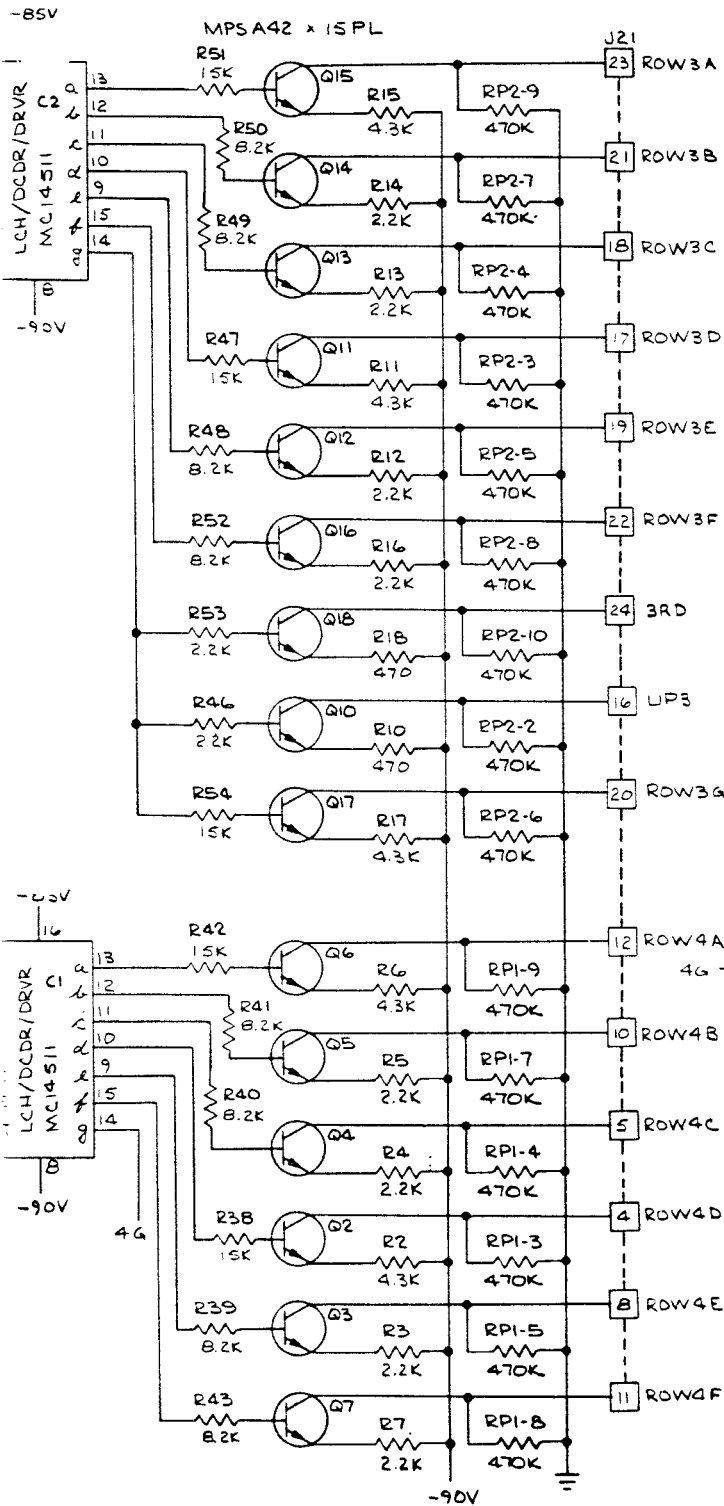

NOTICE TO ALL PERSONS RECEIVING THIS DRAWING  
 CONFIDENTIAL: Reproduction forbidden without the  
 specific written permission of Atari, Inc., Sunnyvale,  
 California. This drawing is only conditionally issued, and  
 neither receipt nor possession thereof confers or transfers  
 any right in, or license to use, the subject matter of the  
 drawing or any design or technical information shown  
 thereon, nor any right to reproduce this drawing or any part  
 thereof, except for manufacture by vendors of Atari, Incor-  
 porated and for manufacture under the corporation's writ-  
 ten license, no right to reproduce this drawing is granted  
 or the subject matter thereof unless by written agreement  
 with or written permission from the corporation.

Figure 27 Score Panel Drive 2 PCB Schematic Diagram  
 020704-01 Sheet 1 of 2 B

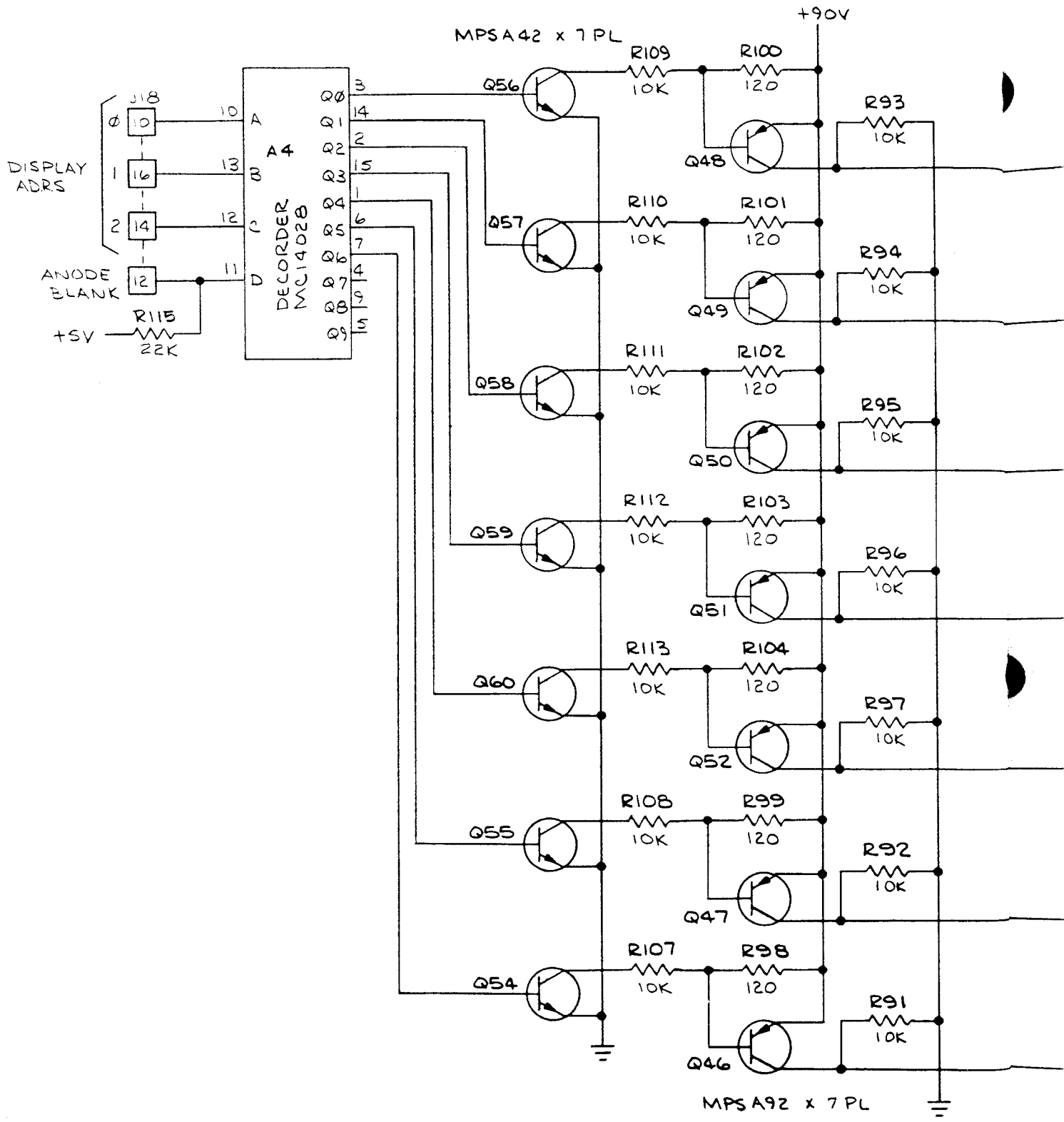

21  
 51 ANODE 2  
 43 ANODE 3  
 7 ANODE 4  
 38 ANODE 5  
 15 ANODE 6  
 27 ANODE 7  
 2 ANODE 1

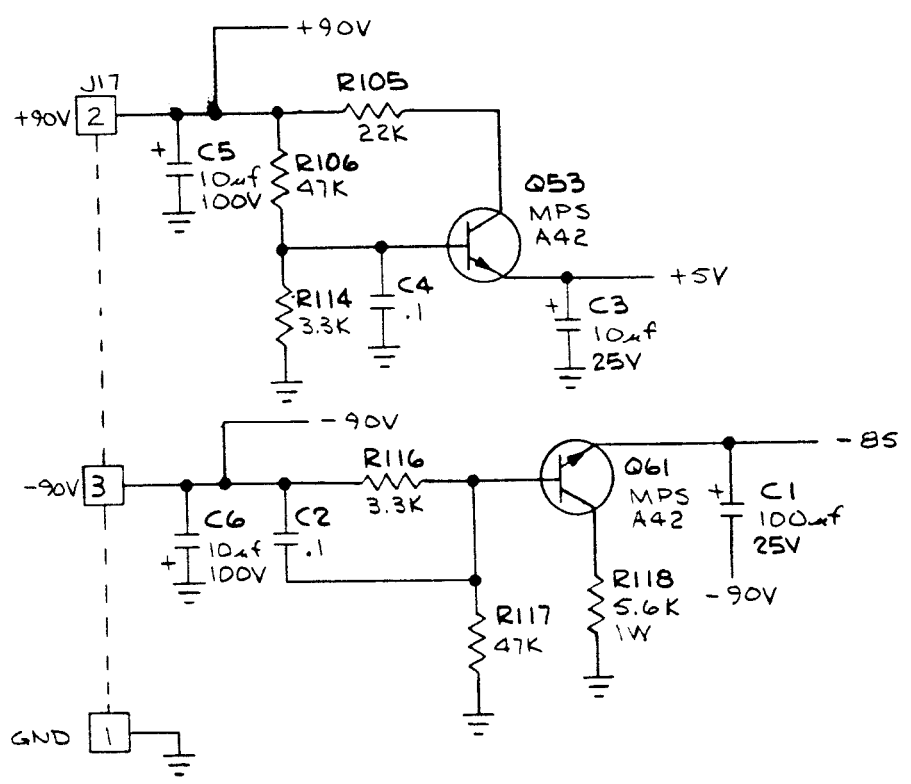

NOTICE TO ALL PERSONS RECEIVING THIS DRAWING  
 CONFIDENTIAL: Reproduction forbidden without the  
 specific written permission of Atari, Inc., Sunnyvale,  
 California. This drawing is only conditionally issued, and  
 neither receipt nor possession thereof confers or transfers  
 any right in, or license to use, the subject matter of the  
 drawing or any design or technical information shown  
 thereon, nor any right to reproduce this drawing or any part  
 thereof, except for manufacture by vendors of Atari, Incor-  
 porated and for manufacture under the corporation's writ-  
 ten license, no right to reproduce this drawing is granted  
 or the subject matter thereof unless by written agreement  
 with or written permission from the corporation.

Figure 27 Score Panel Drive 2 PCB Schematic Diagram  
 020704-01 Sheet 2 of 2 B

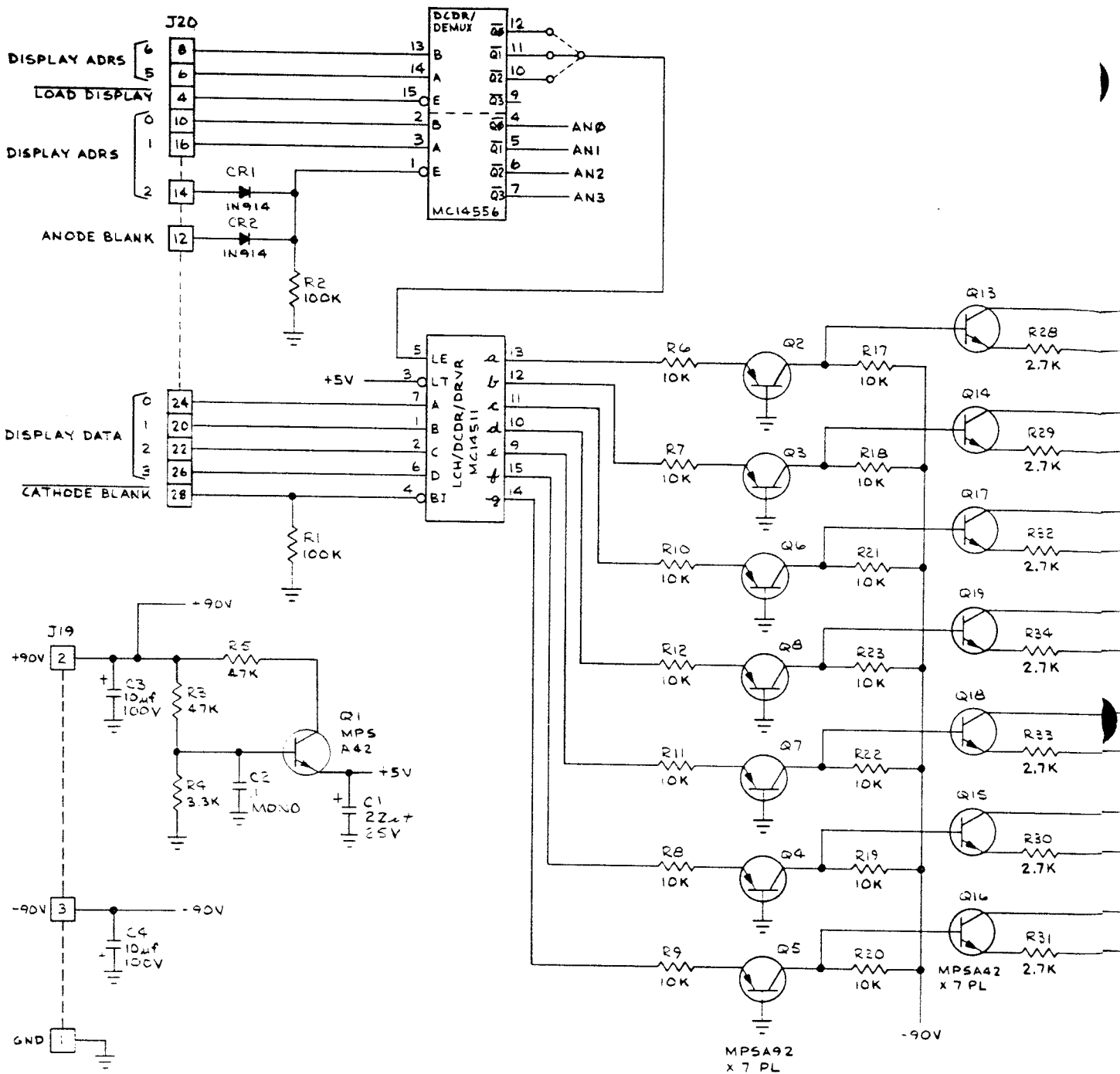

**NOTE**  
See Chapter 5, Illustrated Parts Catalog, for values, sizes, and locations of parts on the Match/Credit PCB.

TO ALL PERSONS RECEIVING THIS DRAWING  
 CONFIDENTIAL: Reproduction forbidden without the  
 permission of Atari, Inc., Sunnyvale,  
 California. This drawing is only conditionally issued, and  
 no possession thereof confers or transfers  
 any license to use, the subject matter of the  
 drawing, or any design or technical information shown  
 thereon, except for manufacture by vendors of Atari, Inc.,  
 and for manufacture under the corporation's written  
 license, no right to reproduce this drawing is granted  
 subject matter thereof unless by written agreement  
 or written permission from the corporation.

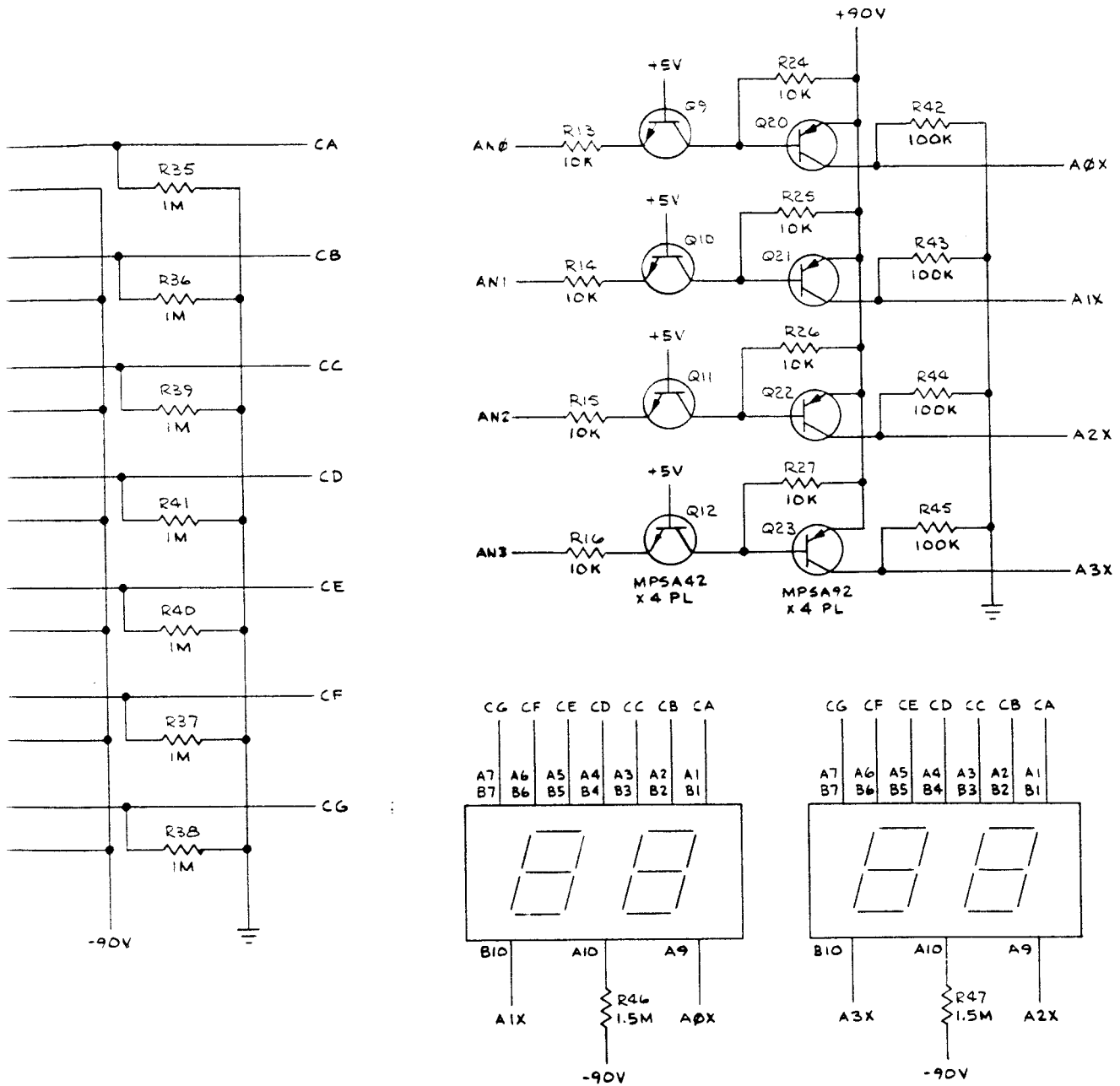

Figure 28 Match/Credit PCB Schematic Diagram  
 030912-01

A

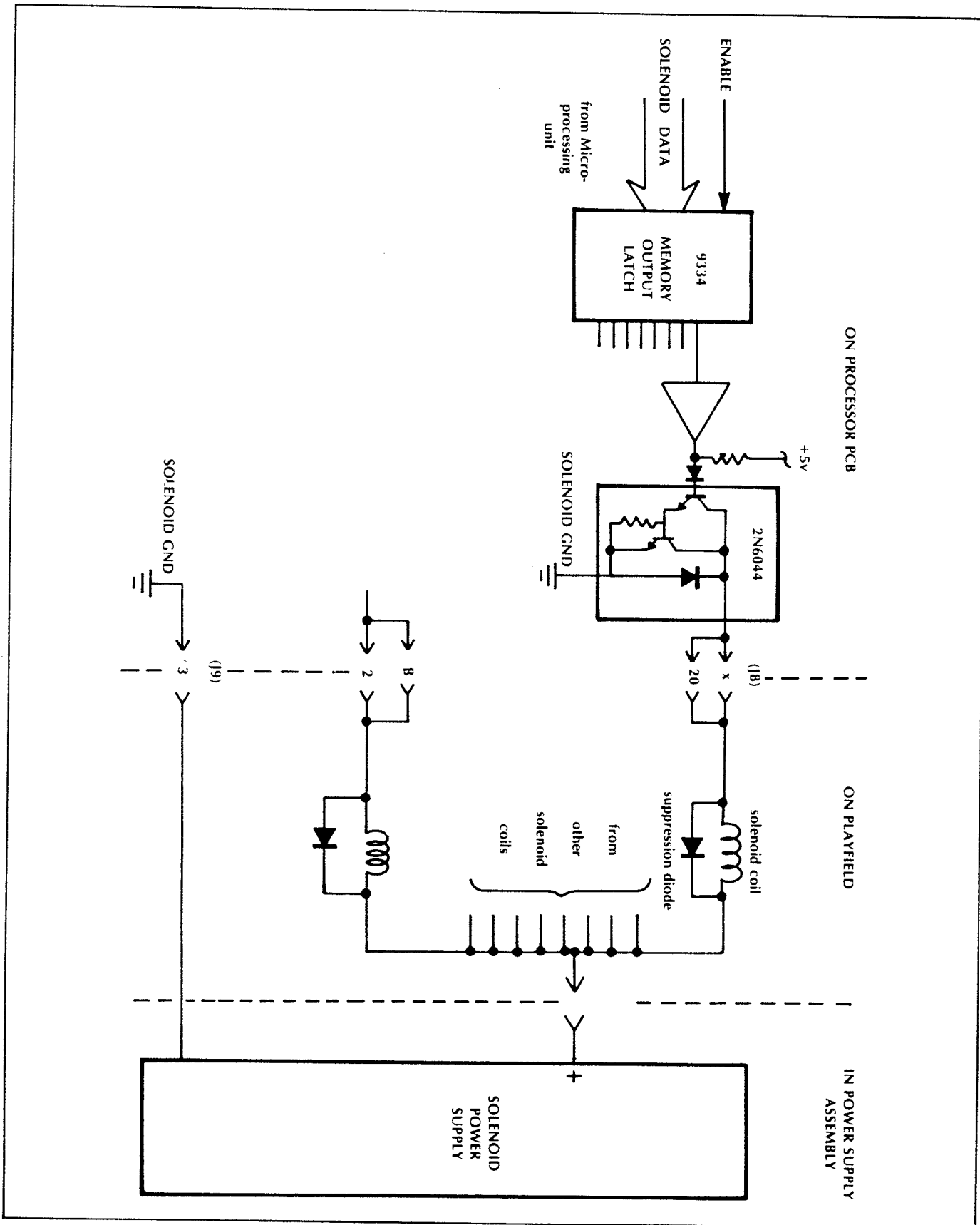
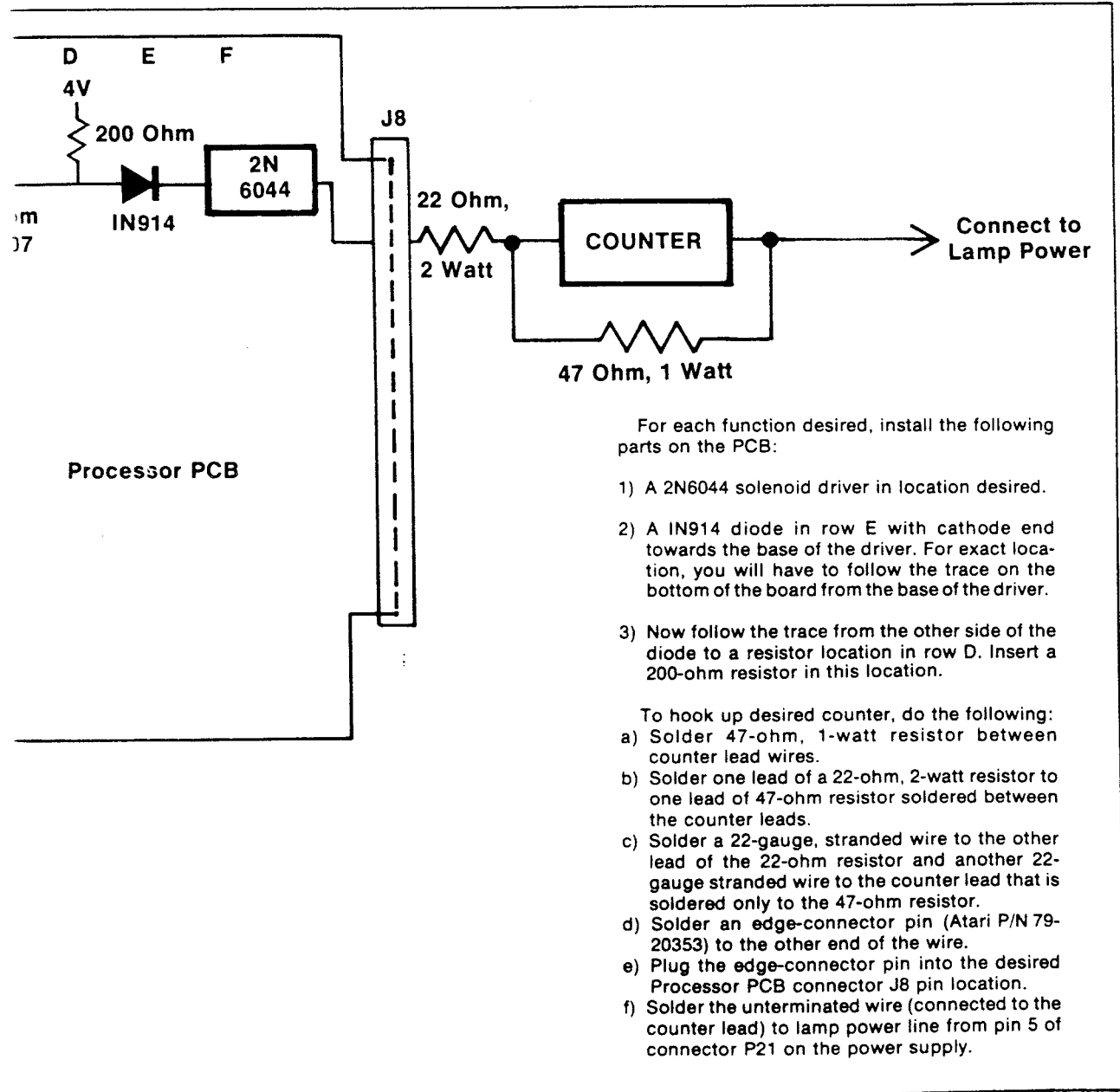

Figure 29 Simplified Diagram of Basic Solenoid Driver Circuit

**Table 4 Components Required for Special Metering Functions**  
(Available at edge connector J-8 on the main processor PCB)

Function Being Metered	Processor PCB Edge Connector J8 Pin	2N6044 Driver Number	1N914 Designation	Resistor Designation
Special replays	X, 20	10	CR20	R25
Special specials awarded	U, 17	19	CR17	R21
Special game time (min.)	V, 18	9	CR18	R24
Special plays	W, 19	20	CR19	R23



For each function desired, install the following parts on the PCB:

- 1) A 2N6044 solenoid driver in location desired.
- 2) A 1N914 diode in row E with cathode end towards the base of the driver. For exact location, you will have to follow the trace on the bottom of the board from the base of the driver.
- 3) Now follow the trace from the other side of the diode to a resistor location in row D. Insert a 200-ohm resistor in this location.

To hook up desired counter, do the following:

- a) Solder 47-ohm, 1-watt resistor between counter lead wires.
- b) Solder one lead of a 22-ohm, 2-watt resistor to one lead of 47-ohm resistor soldered between the counter leads.
- c) Solder a 22-gauge, stranded wire to the other lead of the 22-ohm resistor and another 22-gauge stranded wire to the counter lead that is soldered only to the 47-ohm resistor.
- d) Solder an edge-connector pin (Atari P/N 79-20353) to the other end of the wire.
- e) Plug the edge-connector pin into the desired Processor PCB connector J8 pin location.
- f) Solder the unterminated wire (connected to the counter lead) to lamp power line from pin 5 of connector P21 on the power supply.

**Figure 30 Additional Components to be Installed for Each Metering Function Added**

thirty-two signals connect to the inputs of the type-ULN-2003A devices shown on sheet 4 of the Processor PCB schematic. These are open-collector interface devices that accept TTL input levels, and produce the high current outputs needed to light the lamps. Note that these devices connect to a lamp ground (J9, pin 3).

Figure 32 shows a simplified diagram of the basic lamp driver circuit. One side of each lamp connects to a ULN-2003A output terminal, and the other side connects to a strobe line on the Auxiliary PCB (STROBE A, STROBE B, etc.). In the wiring harness, beneath the playfield, black wires are used for lamps connecting to STROBE A, green wires for those to STROBE B, blue wires for STROBE C, and red wires for STROBE D.

The control logic decodes the LAMP BIT 0 and LAMP BIT 1 signals to produce four transistor based-drive signals, one for each 2N5883. (LAMP BIT 0 and LAMP BIT 1 come from the same circuit that produces the DISPLAY ADRS 1 and DISPLAY ADRS 2 signals on the Processor PCB schematic.) The timing of the four signals driving the 2N5883 transistors is such that any one transistor is brought into conduction only 25% of the time (25% duty cycle). This means that the playfield lamps, which appear to the eye to be of uniform brightness when lighted, are in reality blinking on and off.

#### CAUTION

During troubleshooting of the game by service technicians, while operating the game with the cabinet open and power applied, *do not* hold down the RESET pushbutton (mounted on the Processor PCB) for long periods of time. Doing this will cause one of the 2N5883 transistors to be brought into conduction 100% of the time. Lamp current is very high in this situation, and can lead to premature burning out of the lamps.

#### Switch Sensing Circuit

The switch sensing circuit accepts switch closure information as an input, and produces switch data as an output. This switch data is sent to the microcomputer system on a single signal line. Figure 33 shows a simplified diagram of the switch sensing circuit.

The normally open (NO contacts) of the various playfield switches and certain cabinet switches are connected together in the playfield harness wiring,

and then a common lead is brought to the Processor PCB at connector J7 (pins 5 & 6). (Refer to sheet 2 of the Processor PCB schematic.) On the board's artwork, the NO contacts from the Operator Option Switches (along with signals derived from the rest of the cabinet switches—COIN 1, COIN 2, START, and SLAM), are also connected electronically to this point. Also, this point is connected to resistor R27, tied to +5 volts, and to the pin-13 input of the type-7414 Inverter in location C9. The output of this Inverter, C9 pin 12, is the Switch Data line, which is applied to pin 12 of the type-8097 tri-state buffer in location C5. The device terminal at C5 pin 11 is connected to bit D7 of the Microprocessing Unit's bidirectional Data Bus.

By means of multiplexing technique, the switch closure information being sent on the switch data line is derived from the timing of addressing signals being sent out by the Microprocessing Unit over the Address Bus. To determine whether or not a specific switch is closed, the Microprocessing Unit compares the timing of that switch's address code with the state of the switch data signal being received at that moment on bit D7 of the data bus.

Figure 34 shows simplified waveform diagrams that illustrate this timing comparison multiplex technique for an imaginary circuit having only eleven switches.

In the actual game, anytime that the Microprocessing Unit addresses a specific switch, and that switch is closed at that moment, the SWITCH COMMON line will be low. The 7414 Inverter changes this to high, and a high goes out on the Data Bus on bit D7. So when the Microprocessing Unit reads back a high in that location on the data bus, it knows that the specific switch had been closed.

The control logic used for decoding the Microprocessing Unit's addressing information is shown on the left side of sheet 3 of the schematic. One SWITCH DECODE line is produced for each switch (SWITCH DECODE 200B, SWITCH DECODE 200A, etc.).

#### Displays and Display Data

The Score Display consists of a glass plate panel that plugs into an edge connector, and a printed circuit board beneath that plugs into a second connector. The two connectors are hard-wired together. The Credit and Ball/Match displays are both built on a separate PCB.



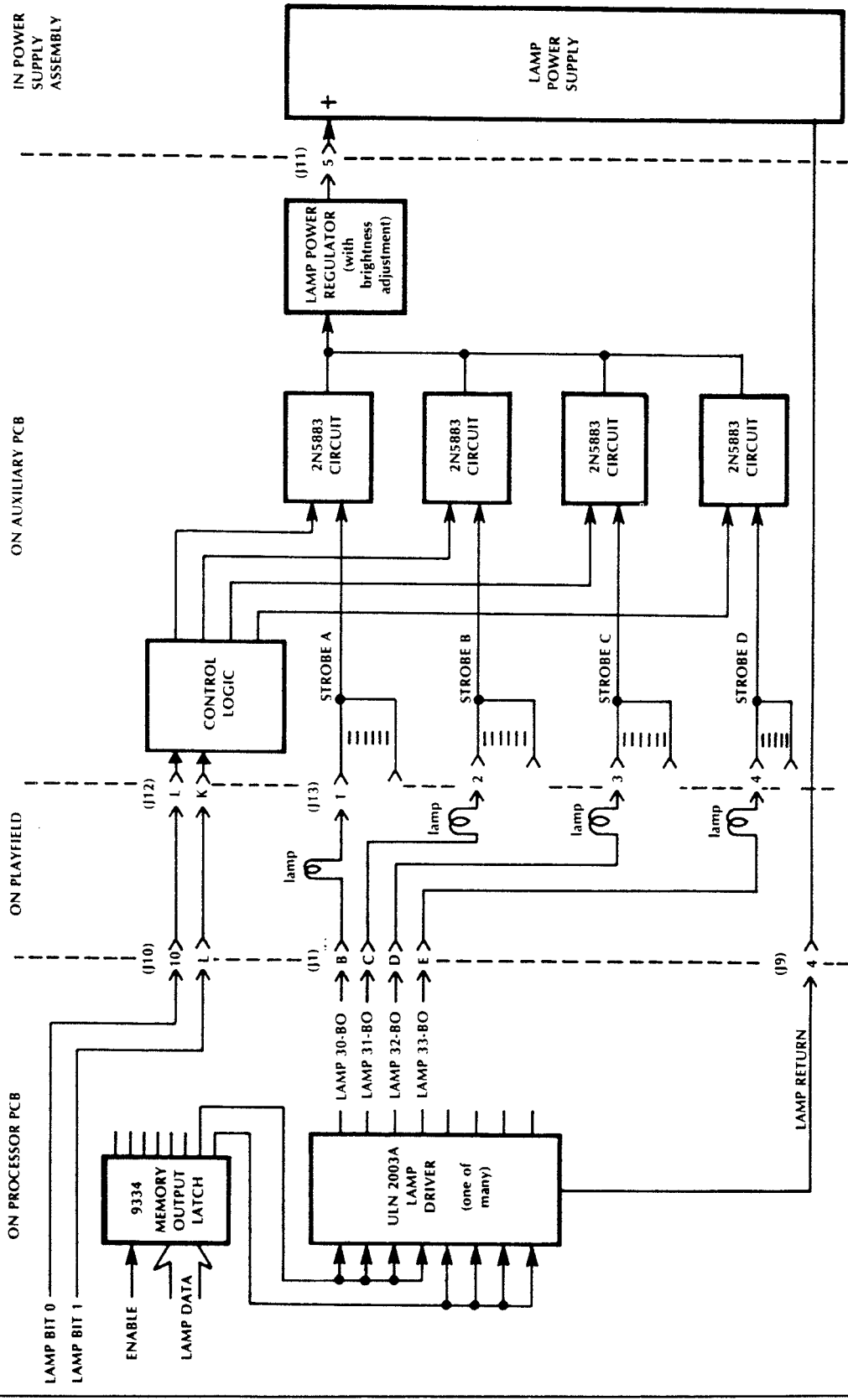

Figure 31 Simplified Diagram of Basic Lamp Driver Circuit

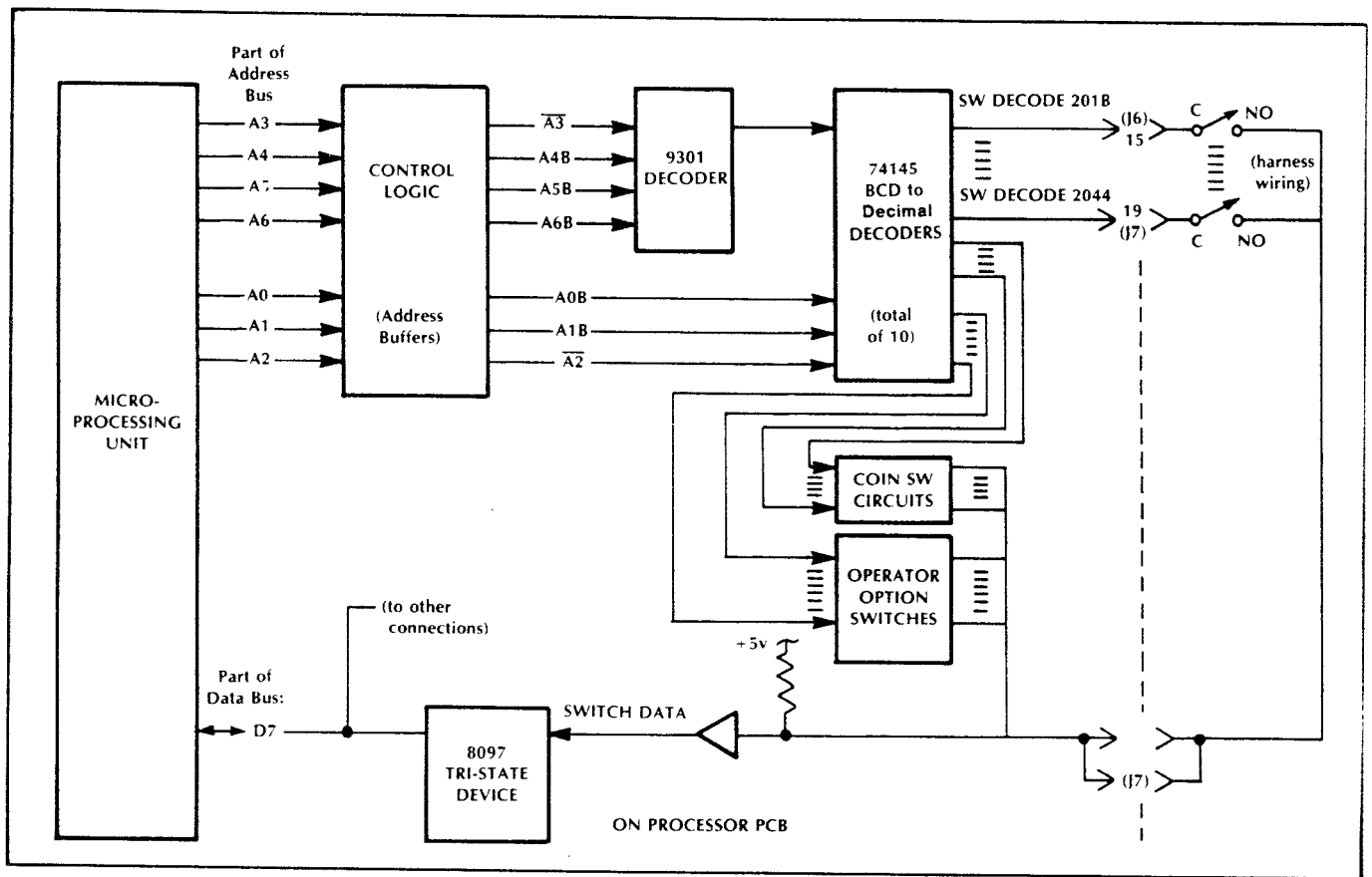

Figure 32 Simplified Diagram of Switch Sensing Circuit

**WARNING**

Whenever AC power is applied to the game, voltage potential differences as large as 180 volts are present at the bare terminals of the glass plate's edge connector, and at various other points on both printed circuit boards.

All three are gas-discharge-type displays with the following principle of operation. If a sufficiently high voltage is applied to a gas, a point will be reached at which the gas ionizes, producing a conduction current and giving off radiation (which can be in the form of visible light). Fluorescent lamps are common examples of illumination sources that also make use of the gas-discharge phenomenon.

A display segment lights up when +90 volts is applied to the anode at the same time that -90 volts is applied to the cathode, as illustrated by the waveforms in Figure 35.

Although to the human eye a lighted segment seems to be uniformly bright, in actuality the segment is being turned on and off at a rate faster than

the eye can detect. This technique is called *segment multiplexing*.

The Microcomputer System block diagram in Figure 23 shows how the microprocessing unit addresses the RAM Data Memory (via the Address Bus) and passes data to this memory (via the Bidirectional Data Bus), and how the Control Logic also shares these buses.

The microprocessing unit brings its BA (Bus Available) signal at C1 pin 7 to high when it is off the buses. During game operation the microprocessing unit periodically writes new display data into the RAM Data Memory and then gives up the buses. Subsequently the Control Logic takes over the buses, addressing the RAM Data Memory and then reading its display data off the Bidirectional Data Bus. The Control Logic then produces the four signals DISPLAY DATA 0 through DISPLAY DATA 3. It also produces seven addressing signals DISPLAY ADRS 0 through DISPLAY ADRS 6, and three control signals ANODE BLANK, CATHODE BLANK and LOAD DISPLAY.

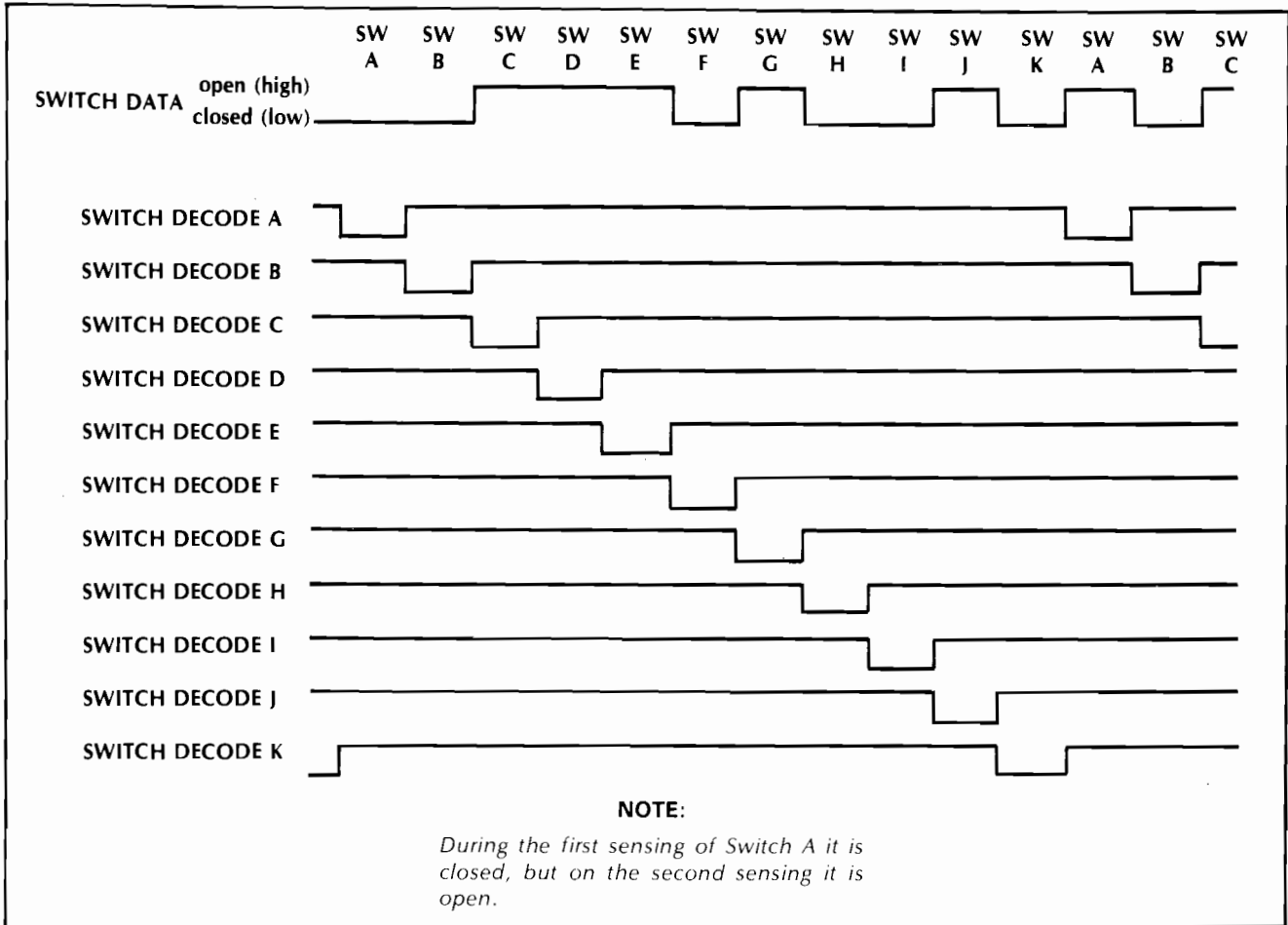

Figure 33 Simplified Diagram of Switch Sensing Circuit Waveforms

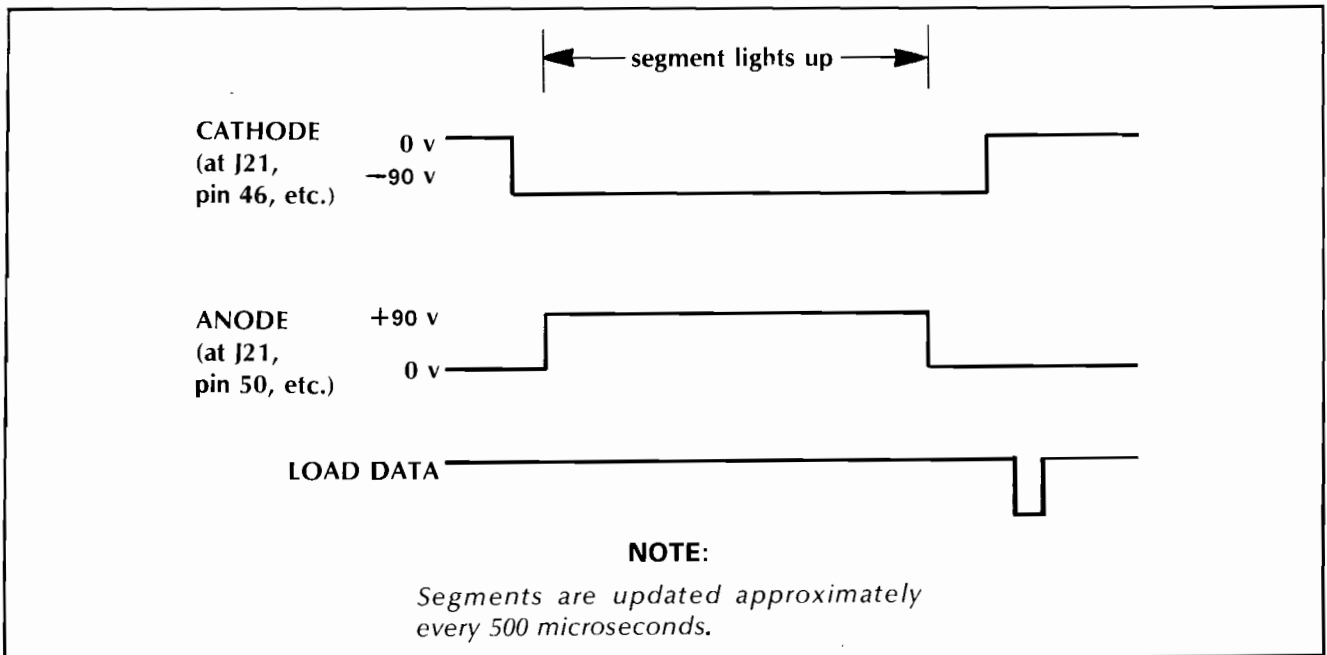

Figure 34 Waveforms for Gas Discharge Displays

The addressing signals are used to identify which displays are to accept data at any given moment. The control signals are used to blank the displays while the microprocessing unit is on the buses, and to strobe in new display data, respectively.

The circuitry for the Control Logic is shown on the right side of sheet 2 of the Processor PCB schematic. The type-74157 2-line to 1-line multiplexer in location B5 produces four DISPLAY DATA signals from the eight inputs D0B through D7B. (These eight signals come from the type-LS08 buffers B/C8 and C/D8 on sheet 1; the buffers are driven directly from the Data Bus signals D0 through D7.) The seven DISPLAY ADRS signals are produced by counters B4 and B3, whose outputs also drive the Address Bus through the type-8097 Tri-State devices C4 and C5. The three display control signals are produced by timing logic driven also by counters B3 and B4, as well as by the  $\overline{BA}$  signal from the microprocessing unit, and by the  $\overline{RESET-A}$  signal from the microcomputer reset circuit.

The circuit for each display consists of an anode drive portion and a cathode drive portion. The anode portions derive timing signals from the DISPLAY ADRS 0 through DISPLAY ADRS 2 signals and the ANODE BLANK control signal. The cathode portions perform three functions: storage of data derived from the DISPLAY DATA signals (under control of the LOAD DISPLAY signal), decoding of this data into 7-segment format, and keeping the segments turned off part of the time (under control of the CATHODE BLANK signal).

The +90 volts and -90 volts required by the displays is produced in a regulated power supply circuit built on the Auxiliary PCB. The 170 VAC input to this circuit comes from the power transformer located in the Power Supply Assembly.

### Credit and Match/Ball Display Circuit

Note that the top half of the Match/Credit PCB Schematic describes the cathode circuitry. The bottom half covers the anode circuitry.

The type-14556 device examines the DISPLAY ADRS 5 and DISPLAY ADRS 6 signals to determine when new data is available for these display digits. The output from the 14556 device is applied to the LE (Latch Enable) input of a type-14511 device. The four signals DISPLAY DATA 0 through 3 are applied to the inputs of a type-14511 device. This device has a latching capability and also performs segment decoding.

The 14511 device's segment outputs are applied to cathode driver network (Q2 thru Q8 and Q13 thru Q19), which produces a 90-volt swing (from 0 volts to -90 volts) at its outputs. The seven outputs from the transistor drivers are applied to the cathode terminals of all display segments. The CATHODE BLANK signal, applied to the B1 input (pin 4 of the 14511 device), will cause all segments to be blank, regardless of what data is stored, when the multiplex timing calls for that digit to remain unlighted.

The anode portion of the circuit, examines the three signals DISPLAY ADRS 0 through 2 outputted from the 14511 device (AN0 thru AN3) to determine which of the display digits to turn on. Anode signals AN0 thru AN3 are supplied to anode drivers (Q9 thru Q12 and Q20 thru Q23) that produces a voltage swing from 0 volts to +90 volts.

### Score Display Circuit

The connections to the score display panel are made in the form of a rectangular matrix, with seven anode connections on one side and 28 cathode connections on the other. Figure 36 illustrates the arrangement of these connections. In the multiplex timing the six vertical rows of digits, plus the one vertical row of *player up* indications, are driven one at a time. All the anodes in the *player up* indications are brought together electrically to J21, pins 1 and 2, the ANODE 1 signal. All the anodes for the least significant digits are brought to J21, pins 50 and 5, the ANODE 2 signal, etc. The sequence of lighting the anodes is: ANODE 2, then 4, then 6, then 3, then 5, then 7, and finally ANODE 1.

Likewise, the cathodes of all segments of the digits in a row are tied together. For example, all the "b" segments in the top row are tied together and brought to J21, pin 46.

For the circuit descriptions that follow, refer to the schematic in Figure 28. The four display address signals (DISPLAY ADRS 3 through 6) are applied to type-14556 devices which produce four outputs. One of these outputs is applied to the LE input (pin 5) of each of the type-14511 Latch/Segment Decoder devices in locations C1, C2, C4, and C5. The 14556 devices decide which of the Latch/Segment Decoders are to receive display data (are to be loaded) at any one moment.

The individual segment outputs ("a" through "g") produced by the segment decoders are applied

through series resistors to eighteen PNP cathode driver (Q1 thru Q36). These cathode driver transistors perform an interfacing function; they accept TTL logic level inputs and they produce a 90-volt swing (from 0 volts to -90 volts) at their outputs.

The circuitry for driving the anodes of the display is shown on the right half of the sheet. The type-14028

device examines the DISPLAY ADR0 through 2 signals to determine which of the seven ANODE lines are to be turned on. The outputs of the 14028 are applied to anode drivers (Q46 thru Q52 and Q54 thru Q60) that produce the 90-volt swing (from 0 volts to +90 volts) at their outputs.

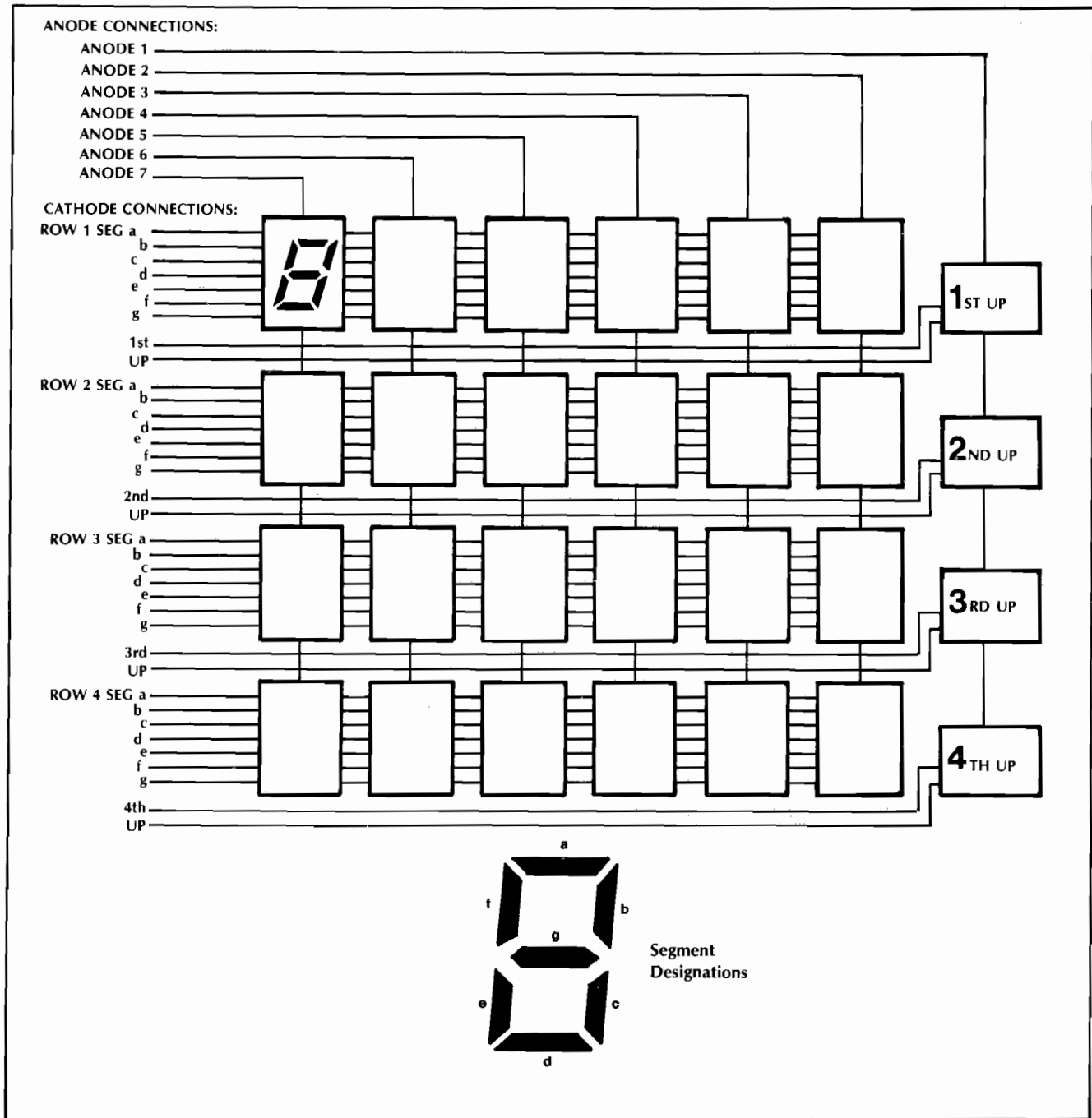

Figure 35 Arrangement of Connections to Score Panel

## Sound Generator and Speaker Driver Circuits

The initial portion of the Sound Generator circuit is built on the Processor PCB: The final portion and the Speaker Driver are built on the Auxiliary PCB. In the lower left corner of sheet 2 of the Processor PCB schematic, four Memory Output Latch signals (LATCH 1088 Bit 0 through LATCH 1088 Bit 3) are applied to the type-9316 counter in location D13. This counter is driven by the AUDIO CLOCK signal and serves as a frequency generator. The counter's TC (terminal count) output (at D13 pin 15) is applied to a second counter configuration formed by two type-7493 counter devices. The AUDIO ENABLE and AUDIO RESET signals (produced by Control Logic section shown on schematic sheet 1) are applied to the R01 and R02 reset inputs of these counters (pins 2 and 3). These two signals control when the game's sound is allowed to come on and when it is kept off.

Five output signals from the 7493 counters, together with four more Memory Output Latch signals (LATCH 1080 BIT 0 through BIT 3), are applied to the address inputs of the ROM device in location D12. This ROM has been pre-programmed to perform a waveform shaping function. The ROM outputs, AUDIO 0 through AUDIO 3, are sent to the Auxiliary PCB.

On the Auxiliary PCB schematic these four AUDIO signals are connected to type-7407 open-collector buffers. The buffer outputs connect, via a "weighted" resistor network, to the pin 3 positive

input of the amplifier in location C1. The network is called "weighted" because of the binary-weighted values of the resistors; 68K ohms is double the value of the 33K-ohms resistor, which is double the value of the 18K-ohm resistor, etc. This weighted resistor-buffer arrangement performs a D-to-A (digital to analog) converter function. Note that other resistors, a 1.5K-ohm to ground and a 1.2K-ohm that connects to +13.6 volts, are also tied into this resistor network.

Four more Memory Output Latch signals (LATCH 1084 BIT 0 through BIT 3) are applied to the Auxiliary PCB. After buffering by type-7407 devices, these signals are applied to the gate inputs (pins 5, 6, 12, and 13) of the type-4016 Quad CMOS Analog Switch in location D2. These four latch outputs provide the amplitude modulation information portion of the Sound Data. The outputs of the type-4016 Analog Switch connect, via another "weighted" resistor network, to the negative input (pin 2) of amplifier C1. Thus the 4016 device provides amplitude or gain control for the amplifier. Amplifier C1 acts as a mixer stage for all the Sound Data, and its output (at C1 pin 6) is applied to the Speaker Drive circuit.

The LM380 amplifier in location D1 serves as the Speaker Driver. Potentiometer R1 provides the game's first speaker volume adjustment. The LM380 output at D1 pin 8 connects, via harness wiring, to the second speaker volume potentiometer. This potentiometer is located inside the cabinet at the front left corner. The wiper of the potentiometer connects directly to the game speaker.

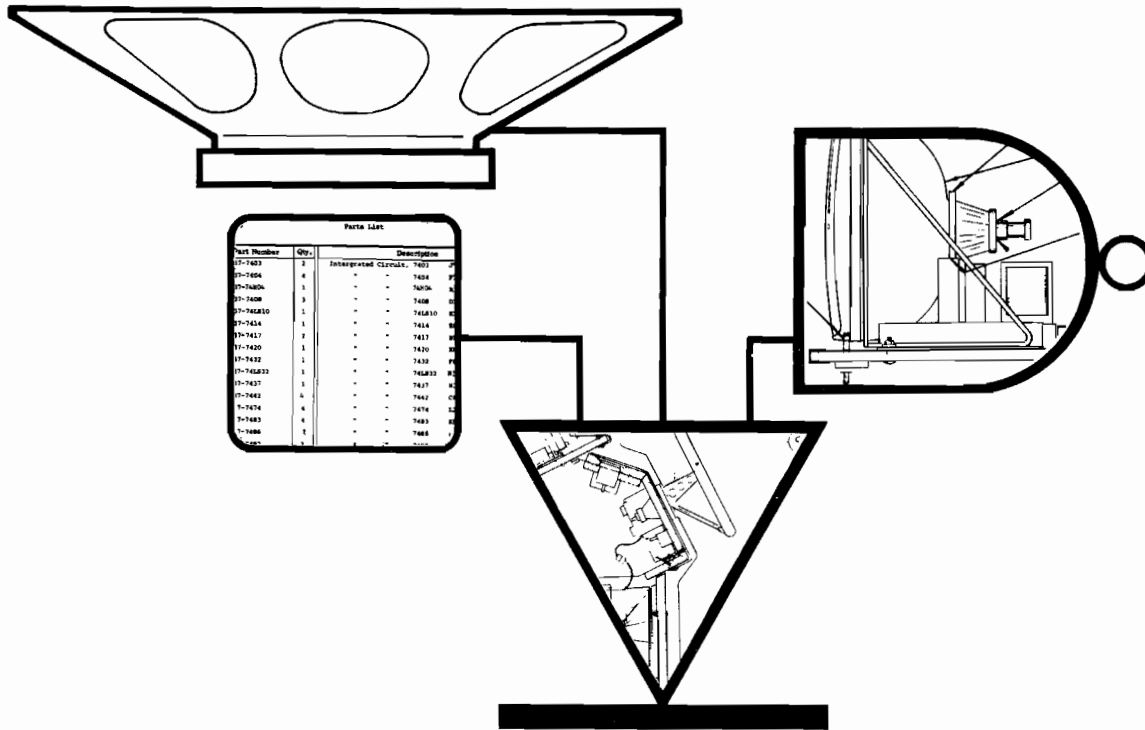

# ILLUSTRATED PARTS CATALOG

The purpose of this chapter is to provide you with the necessary information for ordering replacement parts for the Middle Earth game.

When ordering parts from your distributor, give the part number, part name, and the serial number of your Middle Earth game. This will help to avoid confusion and mistakes in your order. We hope the results will be less downtime and more profit from your game.

If there are any questions about this catalog, please contact Atari's Customer Service Department by telephone Monday through Friday, from 7:30 a.m. to 4 p.m. Pacific Time. From California, Alaska and Hawaii, call (408) 984-1900, from the remaining 47 states call (800) 538-6892 (toll-free).

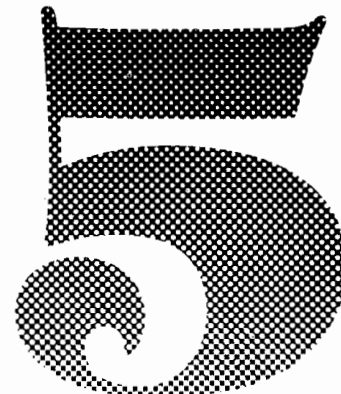



# FINAL LOCATION ASSEMBLY

THE ATARIANS TIME 2000 AIRBORNE AVENGER MIDDLE EARTH

NOTICE TO ALL PERSONS RECEIVING THIS DRAWING  
CONFIDENTIAL Reproduction forbidden without the  
specific written permission of Atari, Inc., Sunnyvale,  
California. This drawing is only conditionally issued, and  
neither receipt nor possession thereof confers or transfers  
any right in, or license to use the subject matter of the  
drawing or any design or technical information shown  
thereon, nor any right to reproduce this drawing or any part  
thereof, except for manufacture by vendors of Atari, Inc.,  
incorporated and for manufacture under the corporation's  
written license, no right to reproduce this drawing is granted  
or the subject matter thereof unless by written agreement  
with or written permission from the corporation.

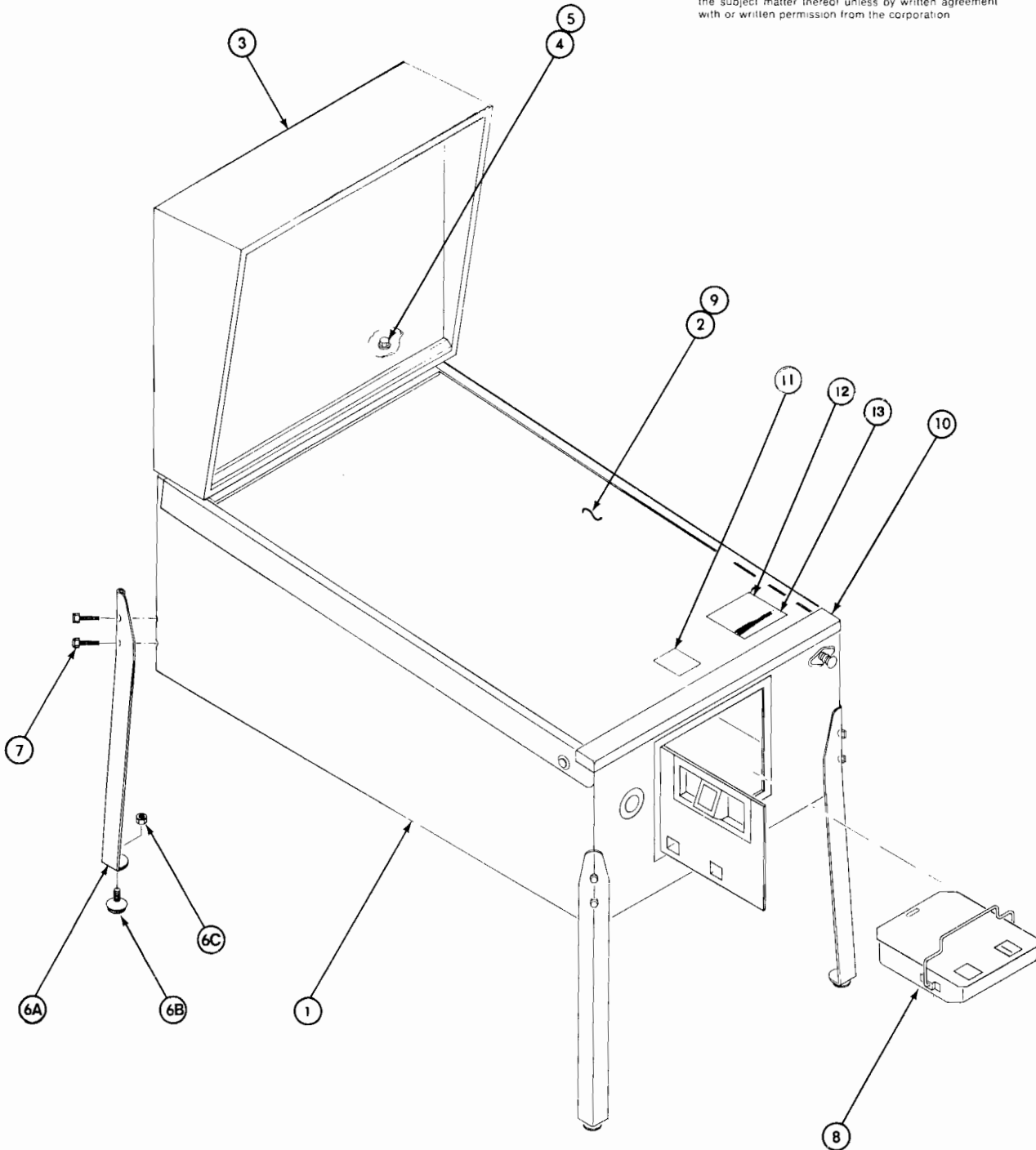

NOTE:  
SEE OTHER SIDE FOR PARTS LIST

A006015-01 thru -09  
A007850-01 thru -09  
A020000-01 thru -09  
A020163-01 thru -09





**FINAL LOCATION ASSEMBLY**  
**THE ATARIANS**    **TIME 2000**    **AIRBORNE AVENGER**    **MIDDLE EARTH**

A006015-01 thru -09  
A007850-01 thru -09  
A020000-01 thru -09  
A020163-01 thru -09

ITEM	PART NUMBER	QTY	DESCRIPTION	FOR MORE INFORMATION
1	A006016-01	1	Cabinet Assembly Used on The Atarians only	See Section B, Sheet 1
	A006016-02	1	Cabinet Assembly Used on Time 2000 only	See Section B, Sheet 1
	A006016-03	1	Cabinet Assembly Used on Airborne Avenger only	See Section B, Sheet 2
	A006016-04	1	Cabinet Assembly Used on Middle Earth only	See Section B, Sheet 2
2	A005988-01	1	Playfield Assembly Used on The Atarians only	See Section F, Sheet 1
	A007852-01	1	Playfield Assembly Used on Time 2000 only	See Section F, Sheet 2
	A020002-01	1	Playfield Assembly Used on Airborne Avenger only	See Section F, Sheet 3
	A020164-01	1	Playfield Assembly Used on Middle Earth only	See Section F, Sheet 4
3	A006986-01	1	Back Box Assembly Used on The Atarians only	See Section D, Sheet 1
	A006986-02	1	Back Box Assembly Used on Time 2000 only	See Section D, Sheet 1
	A006986-03	1	Back Box Assembly Used on Airborne Avenger only	See Section D, Sheet 1
	A006986-04	1	Back Box Assembly Used on Middle Earth only	See Section D, Sheet 1
4	72-5440X	4	# $\frac{3}{8}$ -16x2.5" Full Thread Hex Head Machine Screw	
5	75-07031	4	Special Purpose Flat Washer with I.D. of 0.436", O.D. of 1", and THK. of 0.88"	
6	A006085-01	1	Legs Kit—Consists of items 6A, 6B, and 6C	
6A	004999-01	4	Leg—Part of Legs Kit A006085-01	
6B	78-3201	4	# $\frac{3}{8}$ -16x1.5" Adjustable Swivel Guide—Part of Legs Kit A006085-01	
6C	75-919C	4	# $\frac{3}{8}$ -16 Standard Pattern Hexagon CRES Machine Nut—Part of Legs Kit A006085-01	
7	72-P938N	8	# $\frac{3}{8}$ -16x2 $\frac{3}{8}$ " Nickel Plated Acorn Head Machine Screw	
8	A007902-01	1	Cash Box Assembly—Consists of items 8A, 8B, and 8C	
8A	006316-01	1	Cash Box—Part of Cash Box Assembly A007902-01	
8B	006317-01	1	Cash Box Lid—Part of Cash Box Assembly A007902-01	
8C	006445-01	1	Cash Box Handle—Part of Cash Box Assembly A007902-01	
9	005957-01	1	Playfield Glass	
10	A020195-01	1	Playfield Glass Front Moulding Assy	
11	007040-XX	1	Package of Time 2000 Instruction, Coinage, and Replay Level cards	
11	020264-XX	1	Package of Airborne Avenger Replay Level and Coinage cards	
11	020293-XX	1	Package of Middle Earth Replay Level cards	
12	020263-01	1	Airborne Avenger Instruction card	
12	020292-01	1	Middle Earth Instruction card	
13	020294-XX	1	Package of Middle Earth Coinage cards	
	020295-01	1	5X Scoring label Not identified on drawing	
	TM-086	1	The Atarians Operation, Maintenance and Service Manual	
	TM-099	1	Time 2000 Operation, Maintenance and Service Manual	
	TM-102	1	Airborne Avenger Operation, Maintenance and Service Manual	
	TM-108	1	Middle Earth Operation, Maintenance and Service Manual	

NOTICE TO ALL PERSONS RECEIVING THIS DRAWING  
 CONFIDENTIAL: Reproduction forbidden without the  
 specific written permission of Atari, Inc., Sunnyvale,  
 California. This drawing is not to be used, copied,  
 or otherwise reproduced in any form without the  
 receipt of a written permission from Atari, Inc.,  
 or its authorized agents. No part of this drawing,  
 or any design or technical information shown  
 thereon, nor any right to reproduce this drawing or any part  
 thereof, except for manufacture by vendors of Atari, Inc.,  
 is to be used for any other purpose without the  
 written permission of Atari, Inc. Where no such  
 permission is granted, no right to reproduce this drawing is granted  
 or the subject matter thereof unless by written agreement  
 with or written permission from the corporation.

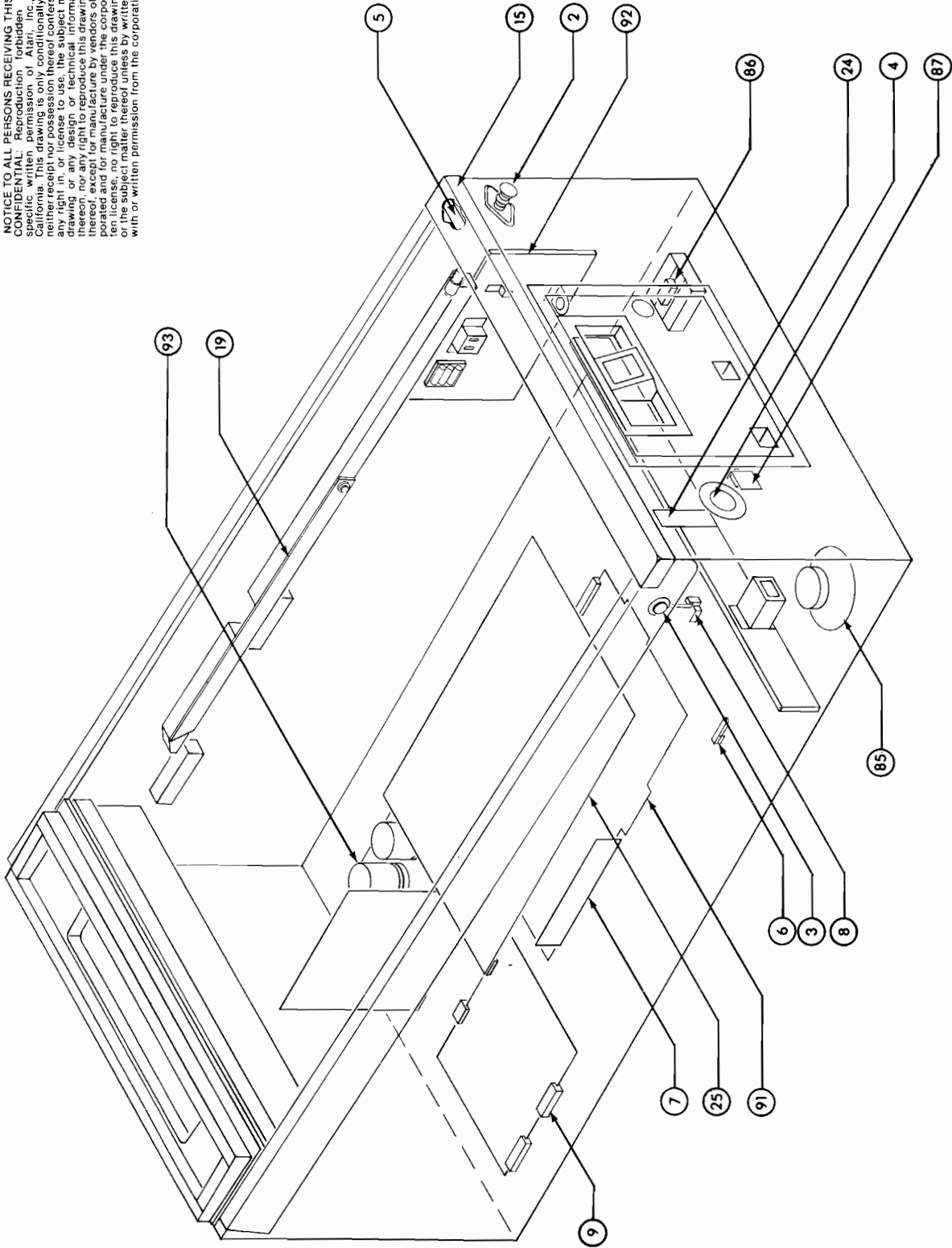

# CABINET ASSEMBLY

## MIDDLE EARTH

### AIRBORNE AVENGER

A006016-04  
 A006016-03 and-04



# CABINET ASSEMBLY

AIRBORNE AVENGER

MIDDLE EARTH

A006016-04  
A006016-03 and-04

Section **B**  
Sheet 2

ITEM	PART NUMBER	QTY	DESCRIPTION	FOR MORE INFORMATION
2	A004769-01	1	Ball Shooter	See Section C, Sheet 1
	75-940S	2	#10-32 Polymer Self-Locking Hex Nut Used for attaching Ball Shooter	
3	A004910-01	2	Flipper Button	See Section C, Sheet 11
	72-6608S	4	#6x1/2" Cross-Recessed Type AB Pan-Head Thread-Forming Steel Screw Used for mounting Flipper Buttons	
4	A007010-01	1	Start Button	See Section C, Sheet 18
	020436-01	1	Start Button Safety Cover Used to cover Wire-Terminals	
	75-5820B	4	#8-32x1 1/4" Black Steel Square-Neck Round-Head Carriage Bolt Used for attaching Start Button	
	75-948S	4	#8-32 Polymer Self-Locking Steel Hex Nut Used for attaching Start Button	
5	A005956-01	1	Locking Base Assy	
	72-6810S	6	#6x5/8" Cross-Recessed Type AB Pan-Head Thread-Forming Steel Screw Used for attaching Locking Base Assy	
6	A004742-01	1	Slam-Switch Assy	
	72-6412S	2	#4x3/4" Cross-Recessed Type AB Pan-Head Thread-Forming Steel Screw Used for attaching Slam-Switch Assy	
7	A020383-06	1	Fuse Board Used on Middle Earth only	
8	A006071-01	1	Flipper Button Switch	
	72-6608S	4	#6x1/2" Cross-Recessed Type AB Pan-Head Thread-Forming Steel Screw Used for attaching Flipper Button Switches	
9	A006407-01	1	Auxiliary PCB	See Section C, Sheet 36
	006762-01	4	Shockmount Spring Used for mounting Auxiliary PCB	
	72-1608S	4	#6-32x1/2" Cross-Recessed Pan-Head Steel Machine Screw Used for attaching Auxiliary PCB to Shockmount Spring	
	75-016S	4	#6 Regular Pattern Plain Flat-Washer Used for attaching Auxiliary PCB to Shockmount Spring	
	75-946S	4	#6-32 Polymer Self-Locking Steel Hex Nut Used for attaching Auxiliary PCB to Shockmount Spring	
	72-6810S	4	#8x5/8" Cross-Recessed Type AB Pan-Head Thread-Forming Steel Screw Used for attaching Shockmount Spring to Cabinet	
	75-018S	4	#8 Regular Pattern Plain Flat-Washer Used for attaching Shockmount Spring to Cabinet	

ITEM	PART NUMBER	QTY	DESCRIPTION	FOR MORE INFORMATION
10	A007866-01	1	Airborne Avenger PCB Power Harness Not identified on drawing	
10	A020418-01	1	Middle Earth PCB Power Harness Not identified on drawing	
11	A007868-01	1	PCB Interconnect Harness Not identified on drawing	
12	A020023-01	1	Display Harness Not identified on drawing	
13	A020235-01	1	Total Play Harness Not identified on drawing	
15	A020195-01	1	Front Moulding Assy	
19	004989-01	2	Support Arm	
	004902-01	2	Flang Bushing Used for attaching Support Arm	
	72-6820S	2	#8x1 1/4" Cross-Recessed Type AB Pan-Head Thread-Forming Steel Screw Used for attaching Support Arm thru Flang Bushing and into Cabinet	
	020440-01	1	Right Stay Arm Bracket Used to support Support Arm	
	020440-02	1	Left Stay Arm Bracket Used to support Support Arm	
	72-6608S	2	#6x 1/2" Cross-Recessed Type AB Pan-Head Thread-Forming Steel Screw Used for mounting right and left Stay Arm Brackets	
20	A020635-01	1	Coin Door for 25-Cent Operation	Section C, Sheet 31
	A020635-02	1	Coin Door for 5-Franc Operation	Section C, Sheet 31
	A020635-03	1	Coin Door for 1-Deutschmarc Operation	Section C, Sheet 31
	A020635-04	1	Coin Door for 1-Krona Operation	Section C, Sheet 31
	A020635-05	1	Coin Door for 100-Yen Operation	Section C, Sheet 31
	A020635-06	1	Coin Door for 10-New Pence Operation	Section C, Sheet 31
	A020635-07	1	Coin Door for Australian 20-Cent Operation	Section C, Sheet 31
24	006719-01	1	Cash Box Locking Strap	
	75-B612	2	#6x 3/4" Phillips Flat-Head Type AB Sheetmetal Screw Used for attaching Cash Box Locking Strap	
	75-015S	4	# 1/4 Regular Pattern Steel Plain Flat-Washer Used for attaching Cash Box Locking Strap	
25	007888-01	1	Black Plastic Processor PCB Shield Never put game into operation without PCB Shield in place	
27	006019-01	4	Retaining Bracket Used for mounting Black Plastic Processor PCB Shield	
	72-1804S	4	#8-32x 1/4" Cross-Recessed Pan-Head Steel Machine Screw Used for attaching Black Plastic Processor PCB Shield to Retaining Brackets	
	75-018S	4	#8 Regular Pattern Plain Steel Flat-Washer Used for attaching Black Plastic Processor PCB Shield to Retaining Brackets	
	72-6810S	4	#8x5/8" Cross-Recessed Type AB Pan-Head Thread-Forming Steel Screw Used for attaching Retaining Brackets to Cabinet	
85	48-004	1	5", 8 ohm, Speaker	
	000869-01	1	Speaker Grill	
	72-1608S	4	#6-32x 1/2" Cross-Recessed Pan-Head Steel Machine Screw Used for attaching Speaker and Speaker Grill	
	75-056	4	#6 Internal-Tooth Steel Lock-Washer Used for attaching Speaker and Speaker Grill	
86	61-062A	1	15Amp @ 125 VAC General Purpose Toggle Switch — Cherry #E69-50A	
	006450-01	1	Switch Plate Used for mounting Toggle Switch	
	72-6810S	2	#8x5/8" Cross-Recessed Type AB Pan-Head Thread-Forming Steel Screw Used for attaching Switch Plate to Cabinet	
	020435-01	1	Power ON/OFF Safety Switch Cover	
	72-6810S	4	#8x5/8" Cross-Recessed Type AB Pan-Head Thread-Forming Steel Screw Used for attaching Safety Switch Cover	
87	68-002	1	30Amp Interlock Switch—Cherry #E79-30A	
	000268-02	1	Interlock Switch Mounting Bracket	
	72-6810S	2	#8x5/8" Cross-Recessed Type AB Pan-Head Thread-Forming Steel Screw Used for attaching Mounting Bracket to Cabinet	
	020435-02	1	Interlock Switch Safety Cover	
90	19-9030	1	100 ohm, 3W, Wire-Wound Linear Variable Resistor Used as the Operator Accessible Volume Control	



**CABINET ASSEMBLY**  
**AIRBORNE AVENGER**  
**MIDDLE EARTH**

A006016-04  
A006016-03 and -04



# CABINET ASSEMBLY

## AIRBORNE AVENGER

## MIDDLE EARTH

A006016-04  
A006016-03 and -04

ITEM	PART NUMBER	QTY	DESCRIPTION	For More Information
	006719-01	1	Locking Strap Used for mounting Volume Control	
	75-B612	1	#6x3/4" Phillips Flat-Head Type AB Sheetmetal Screw Used for attaching Locking Strap (Volume Control Mount)	
91	A006020-08	1	Airborne Avenger Processor PCB	See Section C, Sheet 42
91	A006020-09	1	Airborne Avenger Processor PCB	See Section C, Sheet 42
91	A006020-11	1	Middle Earth Processor PCB	See Section C, Sheet 43
91	A006020-14	1	Middle Earth Processor PCB	See Section C, Sheet 43
91	A006020-15	1	Middle Earth Processor PCB	See Section C, Sheet 43
91	A006020-16	1	Middle Earth Processor PCB	See Section C, Sheet 43
	006762-01	4	Shockmount Spring Used for mounting Processor PCB	
	72-1608S	4	#6-32x1/2" Cross-Recessed Pan-Head Steel Machine Screw Used for attaching Processor PCB to Shockmount Springs	
	75-016S	4	#6 Regular Pattern Plain Flat-Washer Used for attaching Processor PCB to Shockmount Springs	
	75-946S	4	#6-32 Polymer Self-Locking Steel Hex Nut Used for attaching Processor PCB to Shockmount Springs	
	72-6810S	4	#8x5/8" Cross-Recessed Type AB Pan-Head Thread-Forming Steel Screw Used for attaching Shockmount Springs to Cabinet	
	75-018S	4	#8 Regular Pattern Plain Flat-Washer Used for attaching Shockmount Springs to Cabinet	
92	A006728-03	1	95/177V Tilt Board Used on American and Japanese games only	See Section C, Sheet 7
92	A006728-04	1	205/220V Tilt Board Not used on German games	See Section C, Sheet 7
92	A006728-05	1	205/220V Tilt Board Used on German games only	See Section C, Sheet 7
	72-6616	4	#6x1" Cross-Recessed Type AB Pan-Head Thread-Forming Steel Screw Used for attaching Tilt Board to Cabinet	
93	A006020-04	1	117V Power Supply Used on U.S. version of Airborne Avenger only	See Section C, Sheet 23
93	A006020-05	1	220V Power Supply Used on European version of Airborne Avenger only	See Section C, Sheet 23
93	A006020-06	1	220V Power Supply Used on Australian version of Airborne Avenger only	See Section C, Sheet 23
93	A006020-07	1	95V Power Supply Used on Japanese version of Airborne Avenger only	See Section C, Sheet 23
93	A006020-08	1	220V Power Supply Used on English version of Airborne Avenger only	See Section C, Sheet 23
93	A006032-09	1	117V Power Supply Used on American games only	See Section C, Sheet 24
93	A006032-10	1	220V Power Supply Used on Belgian, German, and Scandinavian games only	See Section C, Sheet 24
93	A006032-11	1	220V Power Supply Used on English games only	See Section C, Sheet 24
93	A006032-12	1	220V Power Supply Used on Australian games only	See Section C, Sheet 24
93	A006032-13	1	95V Power Supply Used on Japanese games only	See Section C, Sheet 24
	72-B512	4	#1/4-20x3/4" Hex-Head Steel Bolt Used for attaching Power Supply to Cabinet	
	75-045	4	#1/4" CRES Split Lock-Washer Used for attaching Power Supply to Cabinet	
	75-015S	4	#1/4 Regular Pattern Plain Steel Flat-Washer Used for attaching Power Supply to Cabinet	

NOTICE TO ALL PERSONS RECEIVING THIS DRAWING  
 CONFIDENTIAL - Reproduction forbidden without the  
 specific written permission of Atari, Inc., Sunnyvale  
 California. This drawing is only for informational purposes  
 and neither receipt nor possession thereof confers or confers  
 any right in, or license to use, the subject matter of the  
 drawing or any design or technical information shown  
 thereon, nor any right to reproduce this drawing or any part  
 thereof, except for manufacture by vendors of Atari Incorporated  
 and for manufacture under the corporation's written  
 license, no right to reproduce this drawing is granted or  
 the subject matter thereof unless by written agreement  
 with or written permission from the corporation.

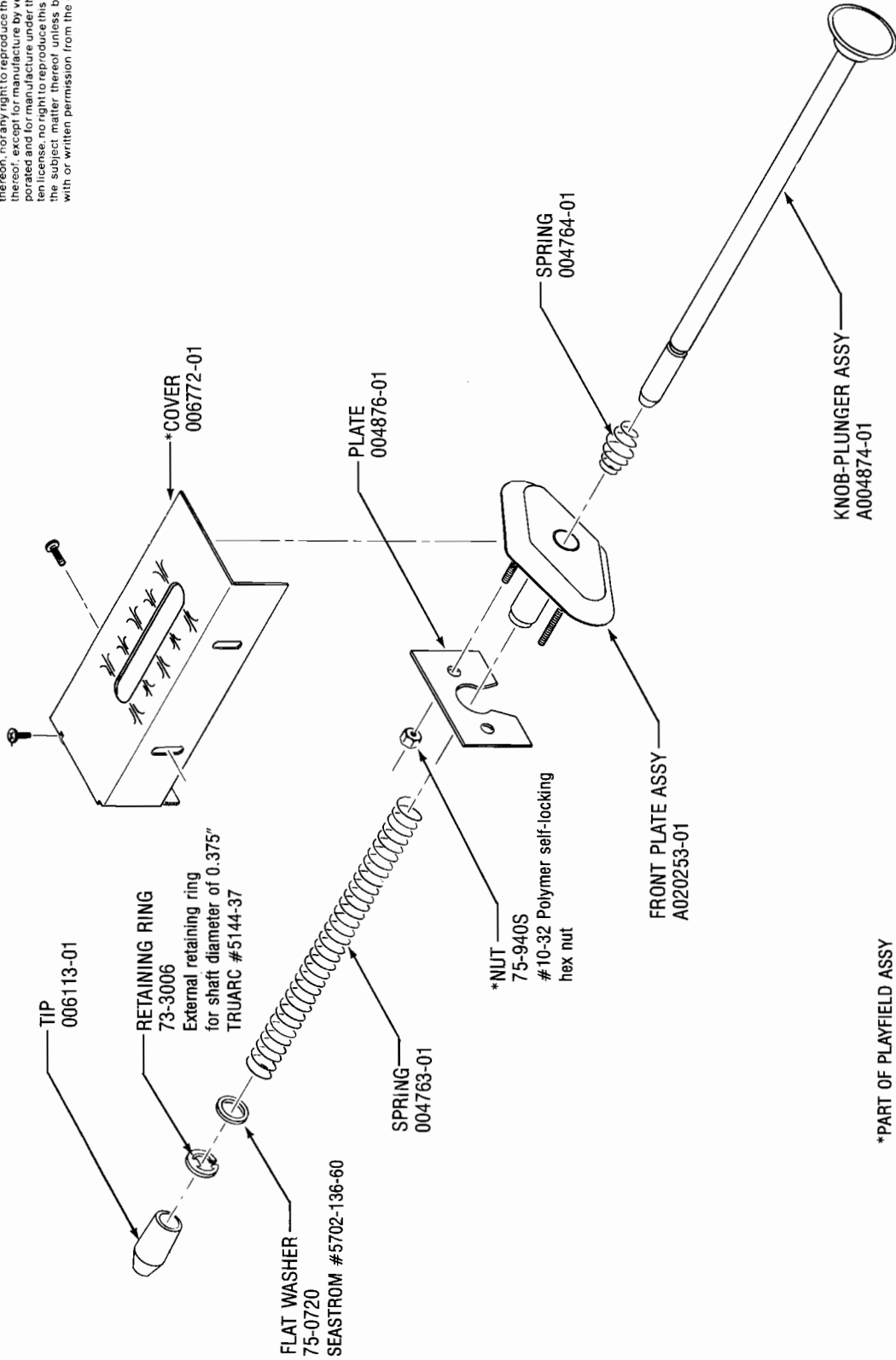

\*PART OF PLAYFIELD ASSY

BALL SHOOTER  
 A004769-01

GABINET SUB-ASSEMBLY



NOTICE TO ALL PERSONS RECEIVING THIS DRAWING  
 CONFIDENTIAL: Reproduction forbidden without the  
 specific written permission of Atari, Inc., Sunnyvale,  
 California. This drawing is only conditionally issued,  
 neither receipt nor possession thereof confers or transfers  
 any right in, or license to, use, the subject matter of the  
 drawing or any design or technical information shown  
 thereon, nor any right to reproduce this drawing or any part  
 thereof, except for manufacture by vendors of Atari incor-  
 porated and for manufacture under the corporation's writ-  
 ten license; no right to reproduce this drawing is granted or  
 the subject matter thereof implied by written agreement,  
 with or without permission from the corporation.

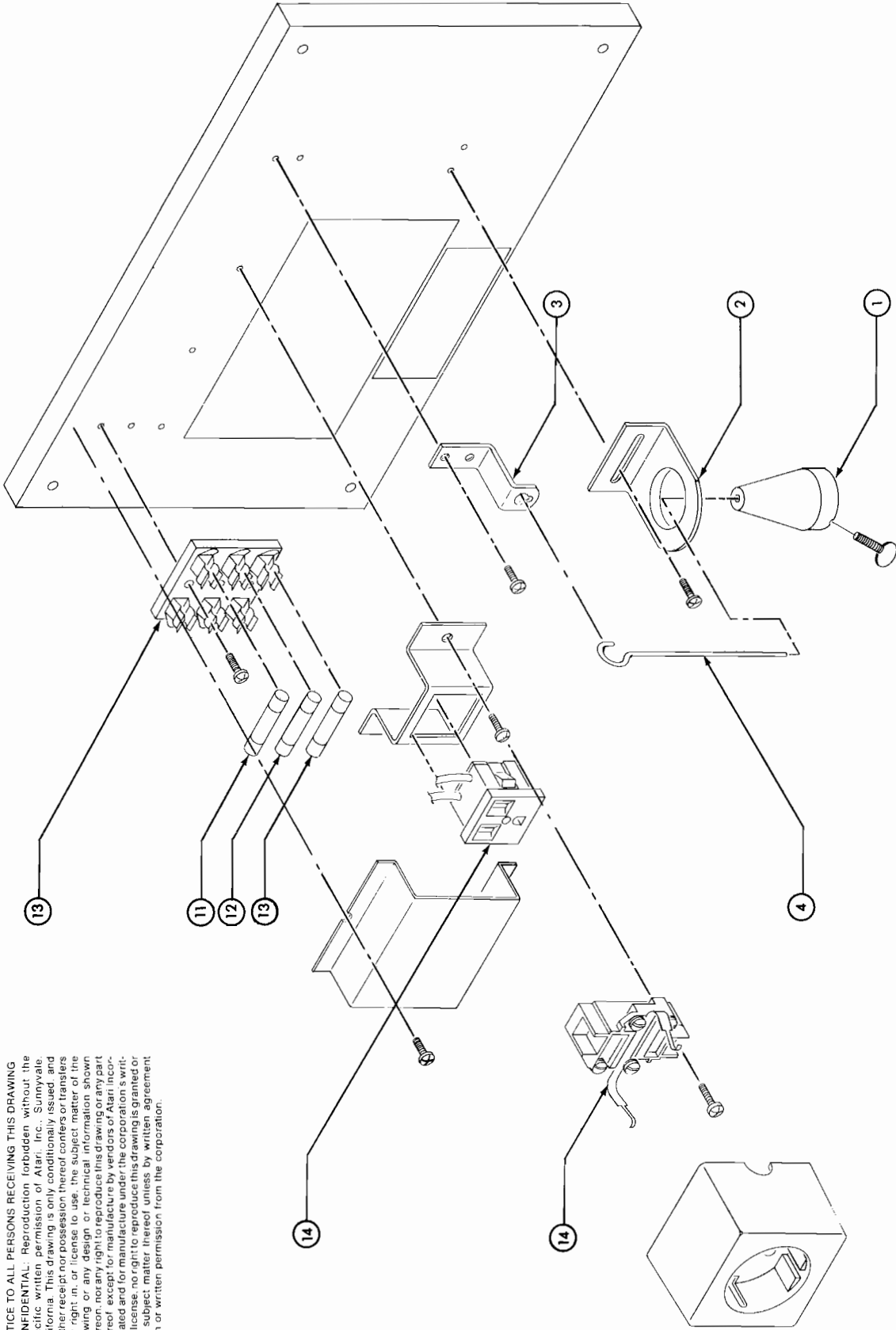

NOTE:  
 SEE OTHER SIDE FOR PARTS LIST



# GABINET SUB-ASSEMBLY

TILT BOARD  
 A006728-03 thru -05



# CABINET SUB-ASSEMBLY

TILT BOARD  
A006728-03 thru -05

Section **C**  
Sheet 7

DESIG-NATION	ITEM	PART NUMBER	DESCRIPTION
F7	11	46-2032002	2Amp @ 250V 3AG Normal-Blow Fuse—LITTLEFUSE #312002
F8	12	46-2017002	7Amp @ 250V 3AG Slow-Blow Fuse—LITTLEFUSE #313007 Used on 95/117V Tilt Board A006728-03 only
F8	12	46-2014002	4Amp @ 250V 3AB Slow-Blow Fuse—BUSSMAN #MDA 4 Used on 205/220V Tilt Board A006728-04 and -05 only
F9	11	46-2032002	2Amp @ 250V Normal-Blow Fuse—LITTLEFUSE #312002
	13	79-3202	Three-Station Fuse Holder—LITTLEFUSE #357003 Used for mounting Fuses F7 thru F9
	18	75-6608S	#6x1/2" Self-Tapping Steel Sheetmetal Screw Quantity of three used for attaching Fuse Holder
J32	14	79-5303	125V, 15Amp, Standard U.S. Grounded A.C. Service Outlet Used on Tilt Board A006728-03 and -04 only
	6	007016-01	Service Outlet Bracket Used on Tilt Board A007728-03 and -04 only
	18	75-6608S	#6x1/2" Self-Tapping Steel Sheetmetal Screw Quantity of two used for attaching Service Outlet Bracket
J32	14	79-5305	220V European Grounded A.C. Service Outlet Used on Tilt Board A006728-05 only
	18	75-6608S	#6x1/2" Self-Tapping Steel Sheetmetal Screw Quantity of three used for attaching Service Outlet J32
S10			Pendulum Tilt Switch Assembly—Consists of the following:
	1	004889-01	Pendulum Tilt Weight
	2	004890-01	Pendulum Tilt Contact Ring
	9	75-6606S	#6x3/8" Self-Tapping Steel Sheetmetal Screw Quantity of two used for attaching Contact Ring
	3	004891-01	Pendulum Tilt Mounting Bracket
	9	75-6606S	#6x3/8" Self-Tapping Steel Sheetmetal Screw Quantity of two used for attaching Mounting Bracket
	4	0048-01	Pendulum Tilt Shaft
	10	82-0816	#8-32x1" Mild-Steel Thumb Screw



NOTICE TO ALL PERSONS RECEIVING THIS DRAWING  
 CONFIDENTIAL: Reproduction forbidden without the  
 specific written permission of Atari, Inc., Sunnyvale,  
 California. This drawing is only conditionally issued, and  
 neither receipt nor possession thereof confers or transfers  
 any right in, or license to use, the subject matter of the  
 drawing or any design or technical information shown  
 thereon, nor any right to reproduce this drawing or any part  
 thereof, except for manufacture by vendors of Atari Incorporated  
 and for manufacture under the corporation's written  
 license, no right to reproduce this drawing is granted or  
 the subject matter thereof, unless by written agreement  
 with or written permission from the corporation.

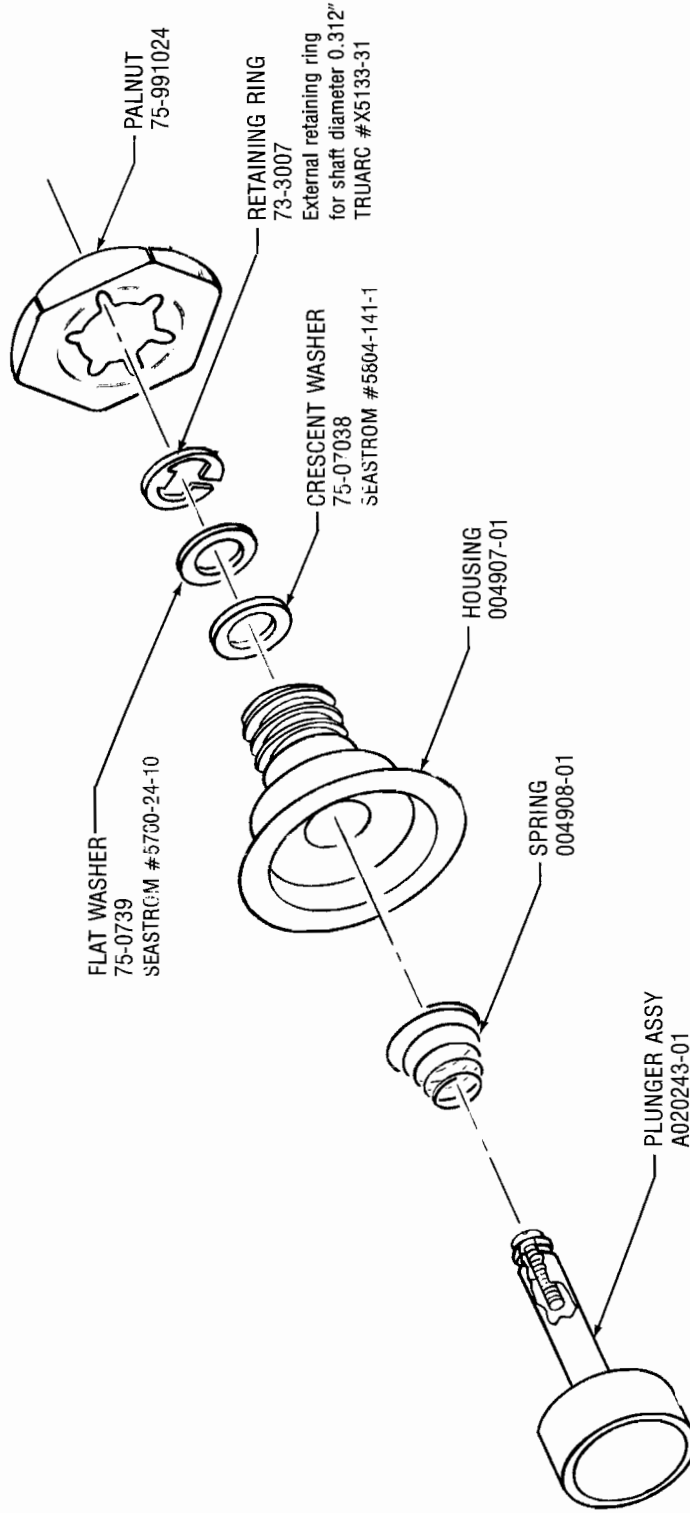

# CABINET SUB-ASSEMBLY

FLIPPER BUTTON  
 A004910-01

NOTICE TO ALL PERSONS RECEIVING THIS DRAWING  
CONFIDENTIAL: Reproduction forbidden without the  
specific written permission of Atari, Inc., Sunnyvale,  
California. This drawing is to be used only conditionally,  
neither receipt nor possession thereof confers or transfers  
any right in or license to use the subject matter of the  
drawing or any design or technical information shown  
thereon, nor any right to reproduce this drawing or any part  
thereof, except for manufacture by vendors of Atari, Incorporated and for manufacture under the corporation's written license; no right to reproduce this drawing is granted or  
the subject matter thereof, unless by written agreement  
with or written permission from the corporation.

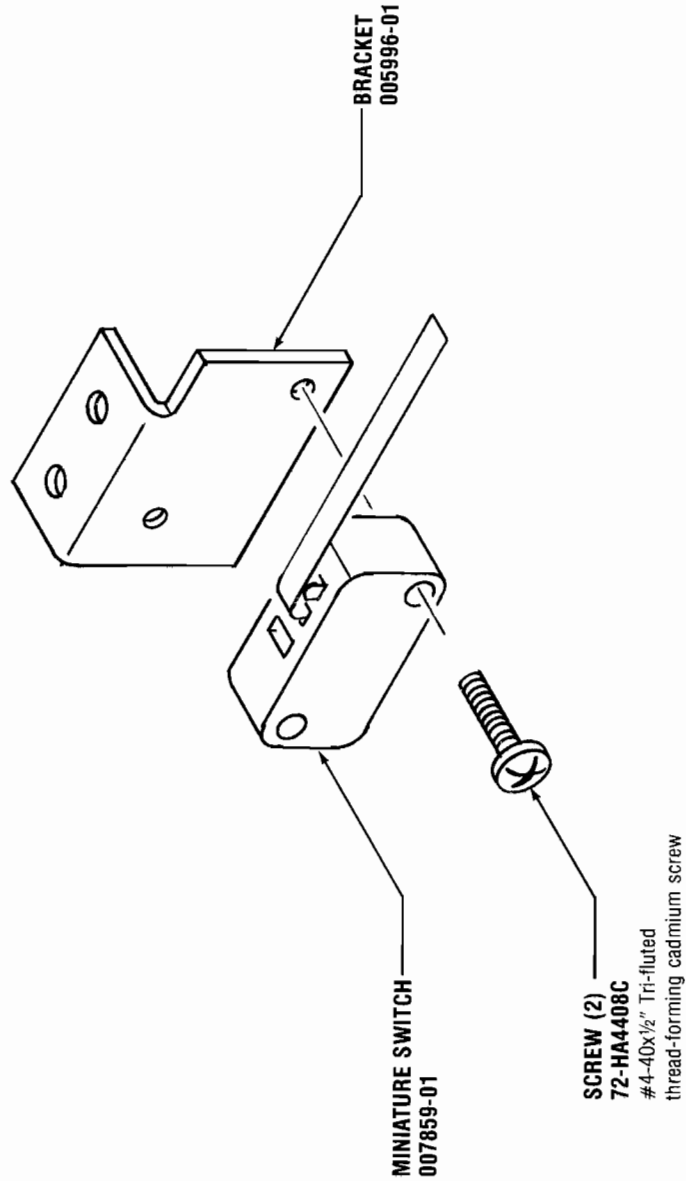

# CABINET SUB-ASSEMBLY

FLIPPER BUTTON SWITCH  
A006071-01

NOTICE TO ALL PERSONS RECEIVING THIS DRAWING  
 CONFIDENTIAL: Reproduction, forbidden, without the  
 specific written permission of Atari, Inc., Sunnyvale,  
 California. This drawing is only conditionally issued, and  
 is not to be used for the production of parts or transfers  
 of any right in or license to use the substance of this  
 drawing or any design or technical information shown  
 thereon, nor any right to reproduce this drawing or any part  
 thereof, except for manufacture by vendors of Atari, Incor-  
 porated, and for manufacture under the corporation's writ-  
 ten permission. This drawing is the property of Atari, Incor-  
 porated, and its use is limited to the specific project and  
 or the subject matter thereof unless by written agreement  
 with or written permission from the corporation.

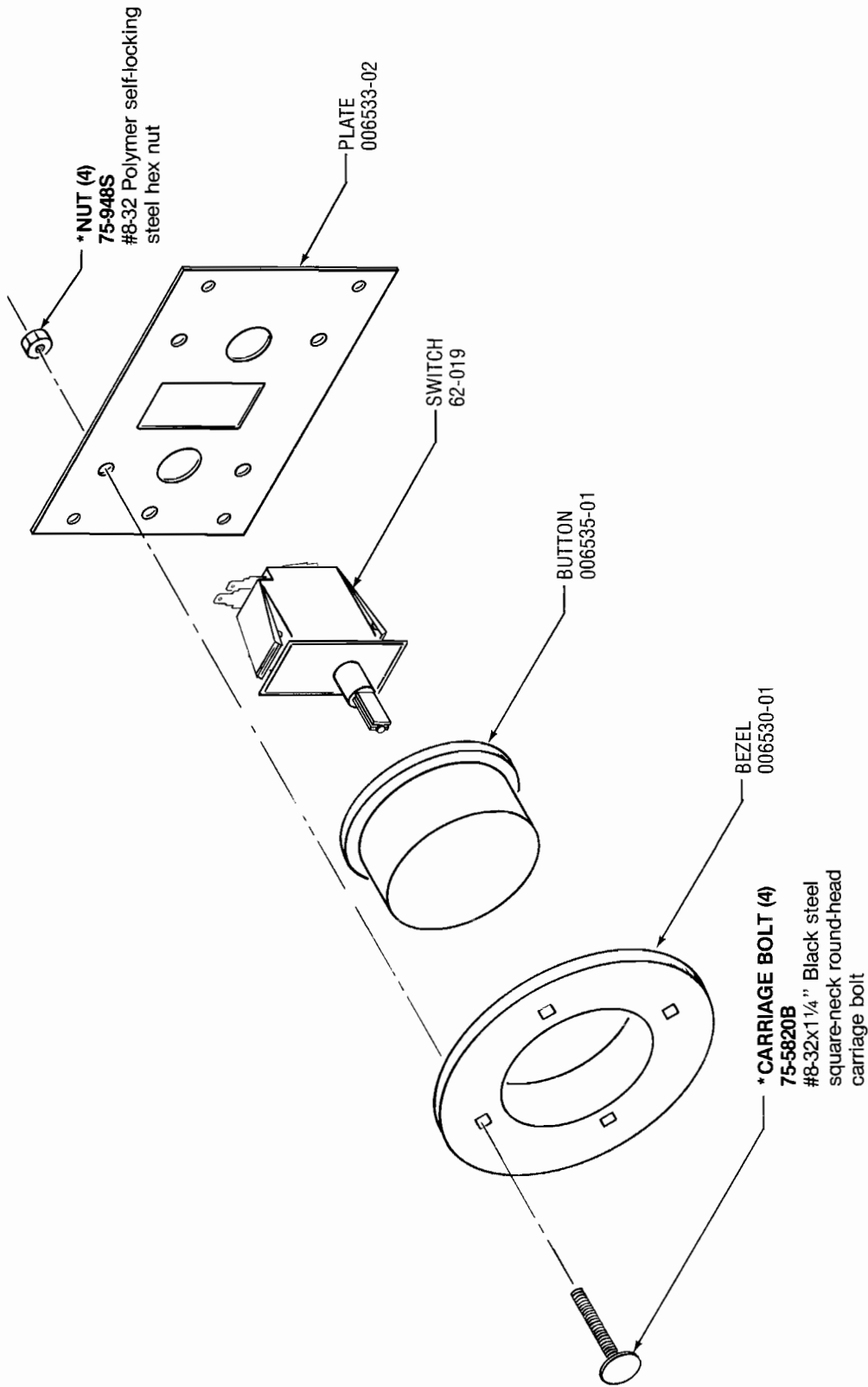

\* Part of Cabinet Assy

START BUTTON  
 A007010-01



# CABINET SUB-ASSEMBLY

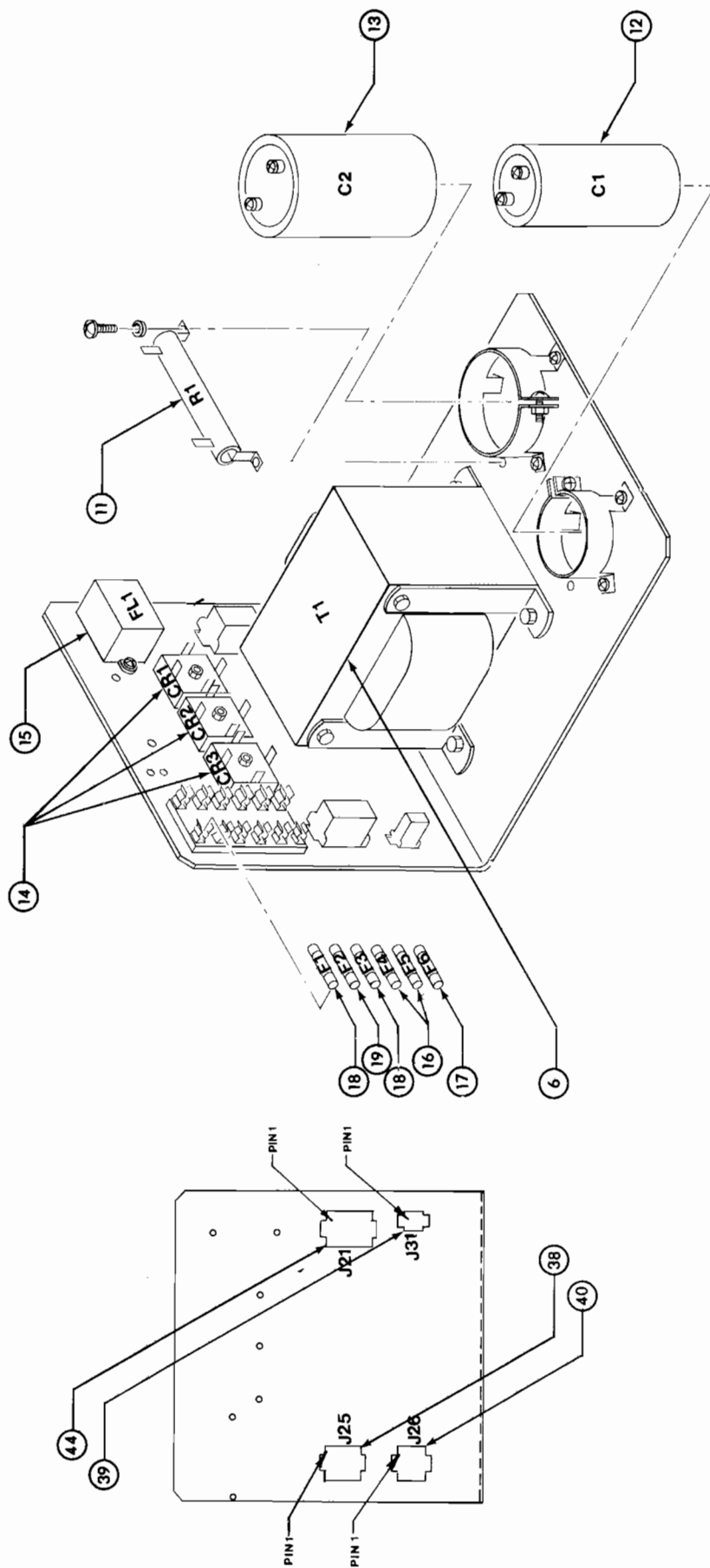

# CABINET SUB-ASSEMBLY

POWER SUPPLY  
A006032-09 thru -13



# CABINET SUB-ASSEMBLY

POWER SUPPLY  
A006032-09 thru -13

Section C  
Sheet 24

DESIG-NATION	ITEM	PART NUMBER	QTY	DESCRIPTION
		A007355-01	1	Power Supply Tray Harness Connects to Resistors R1, Capacitors C1 and C2, Etc. Not identified on drawing.
		A007810-01	1	Power Supply Harness Connects to Filter FL1, Connector J25, etc. Not identified on drawing.
		A007813-01	1	Three Conductor Power Cord Connects to Filter FL1. Not identified on drawing.
		A007862-01	1	Shorting Plug—Not identified on drawing. Mates with Connector J26. Use Black Plug for 95V operation. Use Orange Plug for 117V operation. Use Green Plug for 205V operation. Use Red Plug for 220V operation.
C1	12	29-057	1	18,000uf, +75%, -10%, 25WVDC, Electrolytic Capacitor—SPRAGUE #36D183G025BC2A
		78-70501SC	1	Capacitor Mounting Bracket— SPRAGUE #4586-48 Used for mounting Capacitor C1.
C2	13	29-058	1	21,000uf, +75%, -10%, 40WVDC, Electrolytic Capacitor—SPRAGUE #36D213G040CC2A
		78-70503SC	1	Capacitor Mounting Bracket—Mallory #VR10 Used for mounting Capacitor C2
		72-1608S	2	#6-32x1/2" Cross-Recessed Pan-Head Steel Machine Screw Used for clamping Capacitors C1 and C2 Mounting Brackets
		75-056	2	#6 Internal Tooth Steel Lock-Washer Used for clamping Capacitors C1 and C2 Mounting Brackets
		75-916S	2	#6-32 Standard Pattern Steel Hex Nut Used for clamping Capacitors C1 and C1 Mounting Brackets
		72-1604S	6	#6-32x1/4" Cross-Recessed Pan-Head Steel Machine Screw Used for attaching Capacitors C1 and C2 Mounting Brackets
		75-056	6	#6 Internal Tooth Steel Lock-Washer Used for attaching Capacitors C1 and C2 Mounting Brackets
		72-1006S	4	#10-32x3/8" Cross-Recessed Pan-Head Steel Machine Screw Used for attaching wires to Capacitors C1 and C2
		75-040C	4	#10 CRES Split-Lock-Washer Used for attaching wires to Capacitors C1 and C2
CR1-CR3	14	3A-MDA3500	3	Bridge Rectifier—Motorola #MDA3500
		72-1112S	3	#10-24x3/4" Cross-Recessed Pan-Head Steel Machine Screw Used for attaching Rectifiers CR1 thru CR3
		75-040	3	#10 CRES Split-Lock-Washer Used for attaching Rectifiers CR1 thru CR3



# GABINET SUB-ASSEMBLY

POWER SUPPLY  
A006032-09 thru -13

DESIG-NATION	ITEM	PART NUMBER	QTY	DESCRIPTION
		79-07416V	12	Fixed Insulated Terminal—Hollingsworth #S09721SF Used to attach wired to Rectifiers CR1 thru CR3 Not identified on drawing.
F1	18	46-305152	1	15Amp @ 250V 3AB Normal-Blow Fuse— LITTLEFUZE #314015
F2	19	46-2017002	1	17Amp @ 250V 3AG Slow-Blow— LITTLEFUZE #313007
F3	18	46-305152	1	15Amp @ 250V 3AB Normal-Blow Fuse— LITTLEFUZE #314015
F4, F5	16	46-2010502	2	½Amp @ 250V 3AG Slow-Blow Fuse— LITTLEFUZE #313500
F6	17	46-2032002	1	2Amp @ 250V 3AG Normal-Blow Fuse— LITTLEFUZE #312002
		79-3204	1	Six-Station Fuse Holder—LITTLEFUZE #357006 Used for mounting Fuses F1 thru F6
		72-1606S	2	#6-32x¾" Cross-Recessed Pan-Head Steel Machine Screw Used for attaching Fuseholder
		75-056	2	#6 Internal Tooth Steel Lock-Washer Used for attaching Fuseholder
FL1	15	41-2008	1	10Amp RFI Filter
		72-1604S	2	#6-32x¼" Cross-Recessed Pan-Head Steel Machine Screw Used for attaching Filter FL1
		75-056	2	#6 Internal Tooth Steel Lock-Washer Used for attaching Filter FL1
		79-07416V	4	Fixed Insulated Terminal—Hollingsworth #S09721SF Used for attaching wires to Filter FL1
J21	44	79-58119	1	Fifteen-Pin Connector—AMP #1-480711-0
J25	38	79-58084	1	Twelve-Pin Connector—AMP #1-480709-0
J26	40	79-58117	1	Nine-Pin Connector—AMP #1-480707-0
J31	39	79-58134	1	Two-Pin Connector—AMP #1-480699-0
		79-20123	29	Connector Pin Contact—AMP #350547-1
R1	11	19-8C5W1P0	1	1 Ohm, ±5%, 50W, Wirewound Fixed Resistor— CLAROSTAT #VP50K-1
		72-1604S	2	#6-32¼" Cross-Recessed Pan-Head Steel Machine Screw Used for attaching Resistor R1
		75-057	2	#6 Internal Tooth Steel Lock-Washer Used for attaching Resistor R1
T1	6	006182-01	1	Main Power Transformer
		75-5116N	4	#10-24x1" Round-Head Square-Neck Steel Carriage Bolt Used for attaching Transformer T1
		75-010S	4	#10 SAE Standard Steel Flat Washer Used for attaching Transformer T1

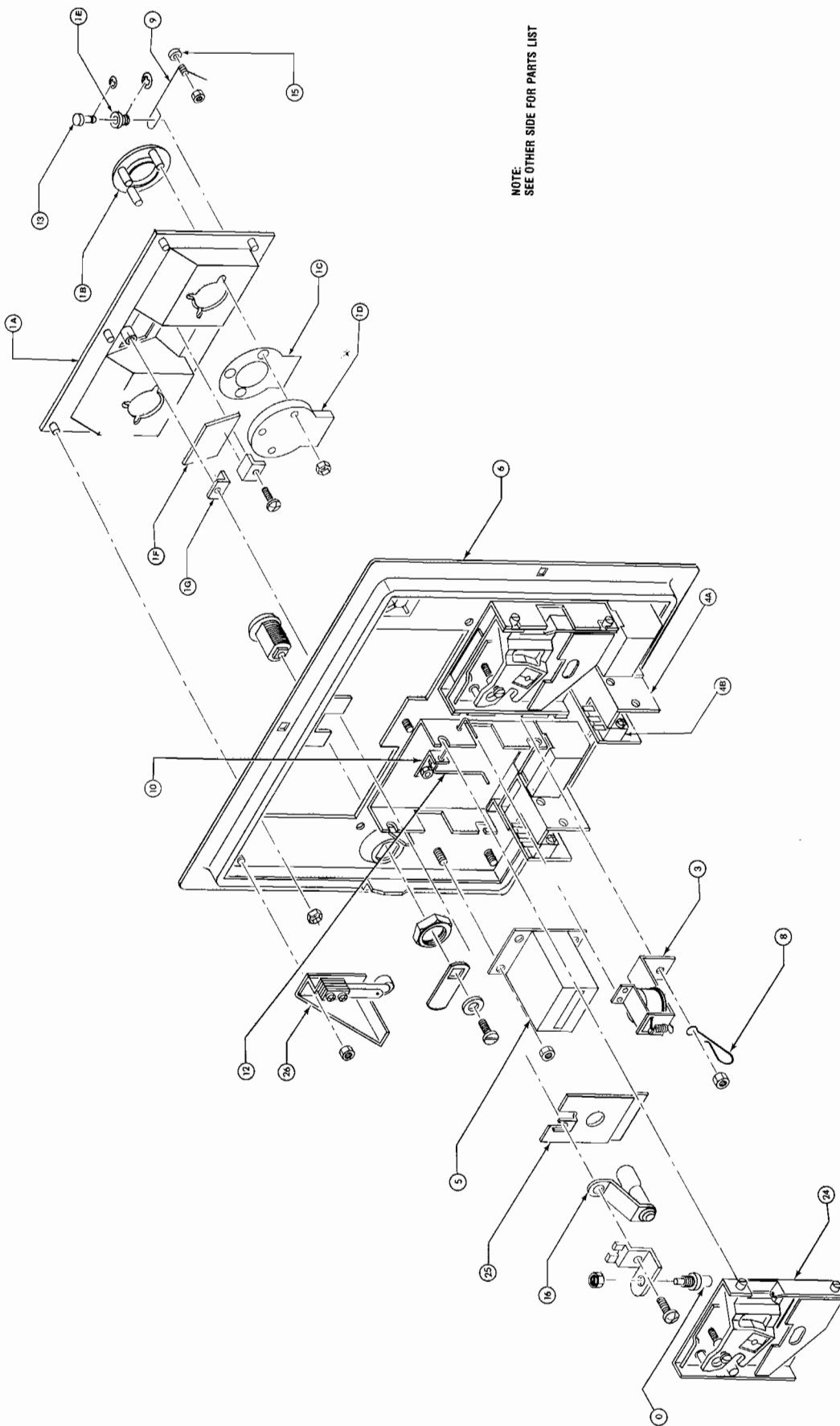

NOTE:  
SEE OTHER SIDE FOR PARTS LIST



# CABINET SUB-ASSEMBLY

COIN DOOR  
A009084-01 thru -09  
A020635-01 thru -09



# CABINET SUB-ASSEMBLY

COIN DOOR  
 A009084-01 thru -09  
 A020635-01 thru -09

Section C  
 Sheet 31

ITEM	PART NUMBER	QTY	DESCRIPTION
0	62-030	1	Subminiature Momentary-Contact Normally-Open SPST Switch — C&K #30-3 Switch identified with TEST designation. Used only on Airborne Avenger Coin Door A020635-01 thru -07
	020386-01	1	Test Switch Bracket Used for mounting TEST switch
	A006794-01	1	Coin Door — Consists of items listed after A006794-07 Used only on 25-Cent Coin Door Assy A020635-01
	A006794-02	1	Coin Door — Consists of items listed after A006794-07 Used only on 5-Franc Coin Door Assy A020635-02
	A006794-03	1	Coin Door — Consists of items listed after A006794-07 Used only on 1-Deutschmarc Coin Door Assy A020635-03
	A006794-04	1	Coin Door — Consists of items listed after A006794-07 Used only on 1-Krona Coin Door Assy A020635-04
	A006794-05	1	Coin Door — Consists of items listed after A006794-07 Used only on 100-Yen Coin Door Assy A020635
	A006794-06	1	Coin Door — Consists of items listed after A006794-07 Used only on 10-New Pence (1-Florin) Coin Door Assy A020635-06
	A006794-07	1	Coin Door — Consists of items listed as follows: Used only on Australian 20-Cent Coin Door Assy A020635-07
1	A007637-01	1	Front Bezel Assy — Consists of items 1A thru 1G Used only on 25-Cent Coin Door A006794-0
1	A007637-02	1	Front Bezel Assy — Consists of items 1A thru 1G Used only on 5-Franc Coin Door A006794-02
1	A007637-03	1	Front Bezel Assy — Consists of items 1A thru 1G Used only on 1-Deutschmarc Coin Door A006794-03
1	A007637-04	1	Front Bezel Assy — Consists of items 1A thru 1G Used only on 1-Krona Coin Door A006794-04
1	A007637-05	1	Front Bezel Assy — Consists of items 1A thru 1G Used only on 100-Yen Coin Door A006794-05
1	A007637-06	1	Front Bezel Assy — Consists of items 1A thru 1G Used only on 10-New Pence (1-Florin) Coin Door A006794-06
1	A007637-07	1	Front Bezel Assy — Consists of items 1A thru 1G Used only on Australian 20-Cent Coin Door A006794-07
1A	004328-01	1	Bezel
	75-991401	6	Thread Cutting Nut — PALNUT # SR188006 Used for attaching Bezel to Coin Door Weldment (item 6)
1B	004330-01	2	Ring Used only on Coin Door A007637-01, -02, and -04
1B	009153-01	2	Ring Used only on Coin Door A007637-03
1B	009520-01	2	Ring Used only on Coin Door A007637-05
1B	007752-01	2	Ring Used only on Coin Door A007637-06 and -07
1C	004331-01	2	Coin Shield
1D	004332-01	2	Primary Coin Chute
	75-9914001	6	Thread Cutting Nut — PALNUT #SR188006 Used for attaching Ring, Coin Shield, and Primary Coin Chute to Bezel
1E	004327-01	2	Scavenger Button Bearing
	73-3009	2	Retaining Ring for Shaft Diameter of 0.375" — TRUARC #5103-37 Used for attaching Scavenger Button Bearing to Bezel
1F	004343-01	1	25-Cent Price Plate
1F	004343-06	1	5-Marc Price Plate
1F	004343-04	1	1-Deutschmarc Price Plate
1F	004343-03	1	1-Krona Price Plate
1F	004343-05	1	100-Yen Price Plate
1F	004343-02	1	10-New Pence (1-Florin) Price Plate
1F	004343-07	1	Australian 20-Cent Price Plate





# CABINET SUB-ASSEMBLY

COIN DOOR  
 A009084-01 thru -09  
 A020635-01 thru -09

ITEM	PART NUMBER	QTY	DESCRIPTION
1G	04329-01	2	Price Plate Clamp Used for attaching Price Plate to the Bezel
	72-1604s	2	#6-32x1/4" Cross-Recessed Pan-Head Steel Machine Screw Used for attaching bottom Price Plate Clamp to Bezel, Top Price Plate Clamp is attached to bezel with screw fed thru Test Switch Bracket (item 0) and Anti-Probe Plate (item 25).
3	A007639-01	1	Coin Lock-Out Assy
	75-00516	2	Used for attaching Key Loop and Coin Lock-Out Assy to Coin Door Weldment studs
4	A007640-01	2	Coin Switch Assy — Consists of items 4A thru 4C. Please note mounting position method of eliminating "Free game" for punching coin door
4A	004342-01	1	Switch Mounting Plate
	75-946C	2	Locknut #6-32 used to hold Switch Mounting Plate on studs from Secondary Coin Chute item 7
4B	65-071C	1	Miniature Switch — Cherry #E51-60B
	72-HA4412	2	#4-40x5/8"
4C	008824-01	1	Wireform
5	A002465-01	1	Coin Counter Assy — Consists of items 5A thru 5C
5A	47-1002	1	
5B	79-58027	1	3-Circuit Plug Shell - Molex #03-09-1031
5C	79-20115	2	Connector Terminal Contract — Molex #02-09-2118
	75-946C	4	Locknut #6-32 Used for attaching Coin Counter Assy to Coin Door Weldment studs.
6	004320-01	1	Coin Door Weldment
7	004341-01	2	Secondary Coin Chute
8	004344-01	1	Key Loop
9	004340-01	2	Return Spring
	75-946C	2	Locknut #6-32 Used for attaching Spring to Weldment Studs
10	004337-01	2	Bracket, Wire Form
	75-946C	4	Locknut #6-32 Used for attaching Bracket to Weldment Studs
	004338-01	1	Lockout Wireform, Right Hand
12	004336-01	1	Lockout Wireform, Left Hand
13	004326-01	2	Scavenger Button
	73-3008	2	'C' Ring used to hold Scavenger Button
15	006904-01	2	Spacer
16	007359-01	1	Lamp Socket
	70-11-47	1	Lamp
	75-946C	1	Locknut #6-32 Used for attaching Lamp Socket to Weldment Stud
	008629-01	2	Return Spring Used to hold Coin Mech in place
23	71-2118	1	Lock Assembly, Hudson
24	71-1225CU	2	Coin Mech 25-Cents for A006794-01
24	71-125FB	2	Coin Mech 5-Franc for A006794-02
24	71-121MG	2	Coin Mech I Deutschmark for A006794-03
24	71-121KS	2	Coin Mech I Krona for A006794-04
24	71-12100YJ	2	Coin Mech 100 Yen for A006794-05
24	71-1210PE	2	Coin Mech 10-New Pence (1-Florin) for A006794-06
24	71-1220CA	2	Coin Mech Australian 20 Cent for A006794-07
25	007753-01	1	Anti-Probe Plate
26	A007638-01	1	Slam Switch Assy
	75-946C	2	Locknut #6-32 Used to hold Slam Switch Assy to Weldment Stud



# CABINET SUB-ASSEMBLY

Auxiliary PCB  
A006407-01

NOTICE TO ALL PERSONS RECEIVING THIS DRAWING  
CONFIDENTIAL: Reproduction forbidden without the  
specific written permission of Atari, Inc., Sunnyvale,  
California. This drawing is only conditionally issued, and  
it is not to be used for any purpose other than that  
for which it was issued. No part of this drawing or  
drawing or any design or technical information shown  
thereon, nor any right to reproduce this drawing or any part  
thereof, except for manufacture by vendors of Atari, Incor-  
porated and for manufacture under the corporation's writ-  
ten permission, is to be disclosed to any third party  
or the subject matter thereof unless by written  
with or written permission from the corporation.

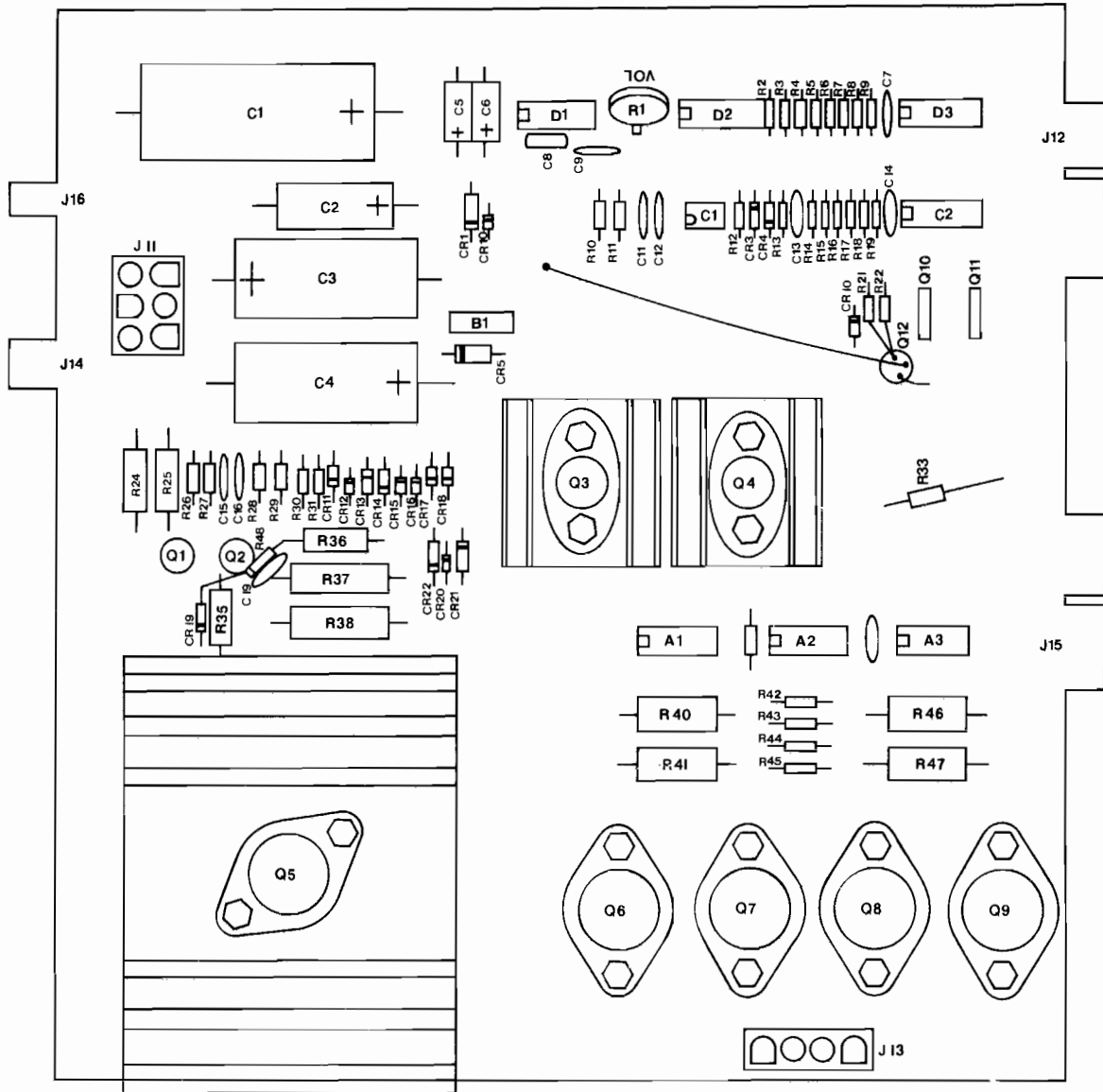



# CABINET SUB-ASSEMBLY

Auxiliary PCB  
A006407-01

DESIG-NATION	LOCA-TION	ITEM	PART NUMBER	DESCRIPTION
C1		18	24-250478	4700 $\mu$ f, +50%, -10%, 25WVDC Electrolytic Capacitor
C2		19	24-250477	470 $\mu$ f, +50%, -10%, 25WVDC Electrolytic Capacitor
C3, C4		16	24-151506	50 $\mu$ f, +50%, -10%, 150WVDC Electrolytic Capacitor
C5		17	24-250106	10 $\mu$ f, +50%, -10%, 25WVDC Electrolytic Capacitor
C6		20	24-350105	1.0 $\mu$ f, +50%, -10%, 25WVDC Electrolytic Capacitor
C7		21	27-250104	0.1 $\mu$ f, $\pm$ 20%, 25V Disc Ceramic Capacitor
C8		23	28-101101	100 $\mu$ f, $\pm$ 5%, 100V Mica Capacitor
C9-C14		21	27-250104	0.1 $\mu$ f, $\pm$ 20%, 25V Disc Ceramic Capacitor
C15, C16		22	27-250103	0.01 $\mu$ f, $\pm$ 20%, 25V Disc Ceramic Capacitor
C18, C19		21	27-250104	0.1 $\mu$ f, $\pm$ 20%, 25V Disc Ceramic Capacitor
CR1		55	32-1N5335	3.9V Zener Diode—Type 1N5335
CR3, CR4		28	32-1N5235	6.8V Zener Diode—Type 1N5235
CR5		27	32-P6KE30	Transient Suppressor Diode
CR10-CR12		26	31-1N4005	General Purpose Rectifier—Type 1N4005
CR13-CR14		30	32-1N4763A	91V Zener Diode—Type 1N4763A
CR15-CR18		26	32-1N4005	General Purpose Rectifier—Type 1N4005
CR19		29	32-1N5242B	12V Zener Diode—Type 1N5242B
CR20		25	31-1N914	General Purpose Signal Diode—Type 1N914
CR21		56	32-1N5230	4.7V Zener Diode—Type 1N5230
CR22		26	32-1N4005	General Purpose Rectifier—Type 1N4005
J11		52	79-58123	4-Pin Header—Amphenol P.N. 350431-1
J13		53	79-58124	6-Pin Header—Amphenol P.N. 350761-4
Q1		33	34-2N3643	Silicon NPN Tuned RF Power Amplifier— Type 2N3643
Q2		31	33-2N3644	Silicon PNP General Purpose Amplifier— Type 2N3644
Q3		34	34-2N3583	Silicon NPN General Purpose Amplifier— Type 2N3583
Q4		37	33-2N6420	Silicon PNP General Purpose Amplifier— Type 2N6420
			72-1408C	#4-40x $\frac{1}{2}$ ' Phillips Pan-Head Stainless Steel Machine Screw Quantity of four used for mounting transistors Q3 and Q4
			75-014S	#4 Flat Steel Washer Quantity of four used for mounting transistors Q3 and Q4
			75-054S	#4 Internal Tooth Steel Lock Washer Quantity of four used for mounting transistors Q3 and Q4
			75-914C	#4-40 Hexagonal Stainless Steel Nut Quantity of four used for mounting transistors Q3 and Q4
			75-09012T	Teflon Shoulder Washer—Seastrom P.N. 5608-69 Quantity of four used for mounting transistors Q3 and Q4
			78-0A01	Nylon Transistor Insulating Cover—Size TO-66 Quantity of two used for covering transistors Q3 and Q4
			78-16011	Thermally Conductive Insulator—Size TO-66 Quantity of two used for mounting transistors Q3 and Q4
			78-06002	Heatsink—Thermalloy P.N. 6111B-66 Quantity of two used for mounting transistors Q3 and Q4

DESIG-NATION	LOCA-TION	ITEM	PART NUMBER	DESCRIPTION
R40, R41 R42-R45 R46, R47 R48	A1 A2, A3 B1 C1	39 42 24 40	13-5390 10-5822 13-5390 10-5204	39 ohm, $\pm 5\%$ , 2W Carbon Composition Resistor 8.2k ohm, $\pm 5\%$ , $\frac{1}{4}$ W Carbon Composition Resistor 39 ohm, $\pm 5\%$ , $\frac{1}{4}$ W Carbon Composition Resistor 200k ohm, $\pm 5\%$ , $\frac{1}{4}$ W Carbon Composition Resistor Darlington NPN Transistor Array—Type MC1413 Quad 2-Input NOR Gate—Type 7402 Full-Wave Bridge Rectifier Network General Purpose Operational Amplifier— Type $\mu$ A741
	C2 D1 D2 D3	43 38 41 43	37-7407 37-LM380 37-4016 37-7407	Hex Buffer/Driver—Type 7407 Audio Power Amplifier—Type LM380 Quad Bilateral Switch—Type CD4016AE Hex Buffer/Driver—Type 7407

DESIG-NATION	LOCA-TION	ITEM	PART NUMBER	DESCRIPTION
Q5		36	34-2N6282 72-1608C 75-016S 75-056S 75-916C 75-0901S 78-0601Z 33-2N5883 72-1608C 75-016S 75-056S 75-916C	Darlington Silicon NPN Power Transistor— Type 2N6282 #6-32x $\frac{1}{2}$ " Phillips Pan-Head Stainless Steel Screw Quantity of two used for mounting transistor Q5 #6 Flat Steel Washer Quantity of two used for mounting transistor Q5 #6 Internal Tooth Steel Lock Washer Quantity of two used for mounting transistor Q5 #6-32 Hexagonal Steel Nut Quantity of two used for mounting transistor Q5 Teflon Shoulder Washer—Seastrom P.N. 5605-25 Quantity of two used for mounting transistor Q5 Modified Heatsink—Wakefield P.N. 641-Y Used for mounting transistor Q5 Silicon PNP General Purpose Amplifier— Type 2N5883 #6-32x $\frac{1}{2}$ " Phillips Pan-Head Stainless Steel Screw Quantity of eight used for mounting transistors Q6-Q9 #6 Flat Steel Washer Quantity of eight used for mounting transistors Q6-Q9 #6 Internal Tooth Steel Lock Washer Quantity of eight used for mounting transistors Q6-Q9 #6-32 Hexagonal Stainless Steel Nut Quantity of eight used for mounting transistors Q6-Q9 5000 ohm Linear Vertical PC Mounting Carbon Trimpot 18k ohm, $\pm 5\%$ , $\frac{1}{4}$ W Carbon Composition Resistor 68k ohm, $\pm 5\%$ , $\frac{1}{4}$ W Carbon Composition Resistor 8.2k ohm, $\pm 5\%$ , $\frac{1}{4}$ W Carbon Composition Resistor 8.2k ohm, $\pm 5\%$ , $\frac{1}{4}$ W Carbon Composition Resistor 33k ohm, $\pm 5\%$ , $\frac{1}{4}$ W Carbon Composition Resistor 8.2k ohm, $\pm 5\%$ , $\frac{1}{4}$ W Carbon Composition Resistor 2.7 ohm, $\pm 5\%$ , $\frac{1}{4}$ W Carbon Composition Resistor 100 ohm, $\pm 5\%$ , $\frac{1}{4}$ W Carbon Composition Resistor 33k ohm, $\pm 5\%$ , $\frac{1}{4}$ W Carbon Composition Resistor 8.2k ohm, $\pm 5\%$ , $\frac{1}{4}$ W Carbon Composition Resistor 1.5k ohm, $\pm 5\%$ , $\frac{1}{4}$ W Carbon Composition Resistor 1.2k ohm, $\pm 5\%$ , $\frac{1}{4}$ W Carbon Composition Resistor 68k ohm, $\pm 5\%$ , $\frac{1}{4}$ W Carbon Composition Resistor 33k ohm, $\pm 5\%$ , $\frac{1}{4}$ W Carbon Composition Resistor 18k ohm, $\pm 5\%$ , $\frac{1}{4}$ W Carbon Composition Resistor 8.2k ohm, $\pm 5\%$ , $\frac{1}{4}$ W Carbon Composition Resistor 200 ohm, $\pm 5\%$ , $\frac{1}{4}$ W Carbon Composition Resistor 15k ohm, $\pm 5\%$ , 1W Carbon Composition Resistor 330 ohm, $\pm 5\%$ , $\frac{1}{4}$ W Carbon Composition Resistor 22 ohm, $\pm 5\%$ , $\frac{1}{2}$ W Carbon Composition Resistor 68k ohm, $\pm 5\%$ , $\frac{1}{4}$ W Carbon Composition Resistor 220 ohm, $\pm 5\%$ , $\frac{1}{4}$ W Carbon Composition Resistor 390 ohm, $\pm 5\%$ , $\frac{1}{2}$ W Carbon Composition Resistor 10k ohm, $\pm 5\%$ , 1W Carbon Composition Resistor 7.5k ohm, $\pm 5\%$ , 5W Carbon Composition Resistor 330 ohm, $\pm 5\%$ , $\frac{1}{4}$ W Carbon Composition Resistor
R1		15	19-311502	5000 ohm Linear Vertical PC Mounting Carbon Trimpot
R2		4	10-5183	18k ohm, $\pm 5\%$ , $\frac{1}{4}$ W Carbon Composition Resistor
R3		8	10-5683	68k ohm, $\pm 5\%$ , $\frac{1}{4}$ W Carbon Composition Resistor
R4		9	10-5822	8.2k ohm, $\pm 5\%$ , $\frac{1}{4}$ W Carbon Composition Resistor
R5		7	10-5333	33k ohm, $\pm 5\%$ , $\frac{1}{4}$ W Carbon Composition Resistor
R6-R9		9	10-5822	8.2k ohm, $\pm 5\%$ , $\frac{1}{4}$ W Carbon Composition Resistor
R10		5	10-52P7	2.7 ohm, $\pm 5\%$ , $\frac{1}{4}$ W Carbon Composition Resistor
R11		57	10-5101	100 ohm, $\pm 5\%$ , $\frac{1}{4}$ W Carbon Composition Resistor
R12		7	10-5333	33k ohm, $\pm 5\%$ , $\frac{1}{4}$ W Carbon Composition Resistor
R13		9	10-8522	8.2k ohm, $\pm 5\%$ , $\frac{1}{4}$ W Carbon Composition Resistor
R14		3	10-5152	1.5k ohm, $\pm 5\%$ , $\frac{1}{4}$ W Carbon Composition Resistor
R15		2	10-5122	1.2k ohm, $\pm 5\%$ , $\frac{1}{4}$ W Carbon Composition Resistor
R16		8	10-5683	68k ohm, $\pm 5\%$ , $\frac{1}{4}$ W Carbon Composition Resistor
R17		7	10-5333	33k ohm, $\pm 5\%$ , $\frac{1}{4}$ W Carbon Composition Resistor
R18		4	10-5183	18k ohm, $\pm 5\%$ , $\frac{1}{4}$ W Carbon Composition Resistor
R19		9	10-5822	8.2k ohm, $\pm 5\%$ , $\frac{1}{4}$ W Carbon Composition Resistor
R21, R22		69	10-5201	200 ohm, $\pm 5\%$ , $\frac{1}{4}$ W Carbon Composition Resistor
R24, R25		11	12-5159	15k ohm, $\pm 5\%$ , 1W Carbon Composition Resistor
R26, R27		6	10-5331	330 ohm, $\pm 5\%$ , $\frac{1}{4}$ W Carbon Composition Resistor
R28, R29		10	11-5220	22 ohm, $\pm 5\%$ , $\frac{1}{2}$ W Carbon Composition Resistor
R30, R31		8	10-5683	68k ohm, $\pm 5\%$ , $\frac{1}{4}$ W Carbon Composition Resistor
R33		67	10-5221	220 ohm, $\pm 5\%$ , $\frac{1}{4}$ W Carbon Composition Resistor
R35		45	11-5391	390 ohm, $\pm 5\%$ , $\frac{1}{2}$ W Carbon Composition Resistor
R36		50	12-5103	10k ohm, $\pm 5\%$ , 1W Carbon Composition Resistor
R37, R38		13	16-5752	7.5k ohm, $\pm 5\%$ , 5W Carbon Composition Resistor
R39		6	10-5331	330 ohm, $\pm 5\%$ , $\frac{1}{4}$ W Carbon Composition Resistor

Auxiliary PCB  
A006407-01



# CABINET SUB-ASSEMBLY

NOTICE TO ALL PERSONS RECEIVING THIS DRAWING  
 CONFIDENTIAL: Reproduction forbidden without the  
 specific written permission of Atari, Inc. Sunnyvale,  
 California. This drawing is the property of Atari, Inc.  
 and is loaned to you for your use only. It is not to be  
 reproduced, distributed, or used in any way without  
 the prior written consent of Atari, Inc. If you have  
 any right in, or license to use, the subject matter of the  
 drawing or any design or technical information shown  
 thereon, nor any right to reproduce this drawing or any part  
 thereof, except for manufacture by vendors of Atari, Inc.,  
 you must execute a license agreement with Atari, Inc.  
 or the subject matter thereof unless by written agreement  
 with or written permission from the corporation.

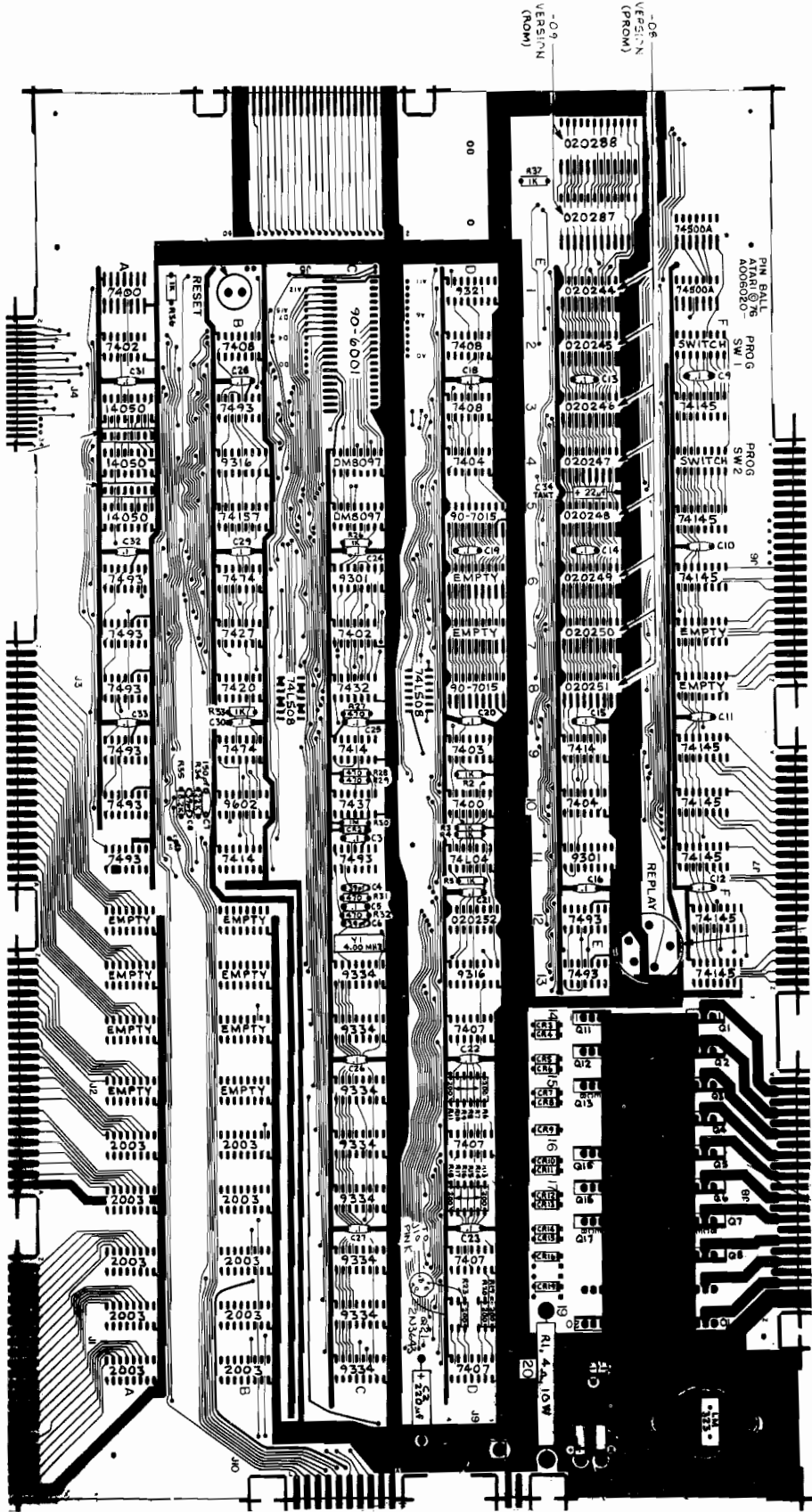

# GABINET SUB-ASSEMBLY

Processor PCB  
 A006020-11, -14, -15, and -16



# CABINET SUB-ASSEMBLY

Processor PCB  
A006020-11, -14, -15, and -16

DESIG-NATION	LOCA-TION	ITEM	PART NUMBER	DESCRIPTION
C1		16	29-006	1 $\mu$ f, $\pm$ 10%, 35V Electrolytic Tantalum Capacitor
C2		12	24-250227	220 $\mu$ f, +50%, -10%, 25V Axial Lead Fixed Electrolytic Capacitor
C3		13	27-250104	0.1 $\mu$ f, $\pm$ 20%, 25V Disc Ceramic Capacitor
C4		14	28-101390	39 $\mu$ $\mu$ f, $\pm$ 5%, 100V Radial Lead Dipped Mica Capacitor
C5		13	27-250104	0.1 $\mu$ f, $\pm$ 20%, 25V Disc Ceramic Capacitor
C6		14	28-101390	39 $\mu$ $\mu$ f, $\pm$ 5%, 100V Radial Lead Dipped Mica Capacitor
C7		15	28-101151	150 $\mu$ $\mu$ f, $\pm$ 5%, 100V Radial Lead Dipped Mica Capacitor
C8		14	28-101390	39 $\mu$ $\mu$ f, $\pm$ 5%, 100V Radial Lead Dipped Mica Capacitor
C9-C33		13	27-250104	0.1 $\mu$ f, $\pm$ 20%, 25V Disc Ceramic Capacitor
C34		17	29-007	22 $\mu$ f, $\pm$ 10%, 15V Electrolytic Tantalum Capacitor
CR1		20	32-P6KE18	Transient Suppressor Diode General Semiconductor Industries P.N. P6KE18
CR2-CR6, CR8-CR15		19	31-1N914	General Purpose Silicone Signal Diode—Type 1N914
CR19		63	79-58122	4-Pin Header
J9		46	37-LM323	Voltage Regulator—Type LM323
LM323		54	72-1608S	#6-32x1/2" Phillips Pan-Head Steel Machine Screw Quantity of two used for mounting Regulator LM323
		55	75-016S	#6 Flat Steel Screw Quantity of two used for mounting Regulator LM323
		56	75-056S	#6 Internal Tooth Steel Lock Washer Quantity of two used for mounting Regulator LM323
		57	75-916S	#6-32 Hexagonal Cadmium Nut Quantity of two used for mounting Regulator LM323
		58	78-06001	Heatsink—Wakefield P.N. 690 Used for mounting Regulator LM323
		59	78-16005	Thermally Conductive Insulator for size TO-3 Used for mounting Regulator LM323
Q1-Q7, Q11, Q12, Q15-Q17, Q20 Q21		21	34-2N6044	Darlington Silicone NPN Transistor—Type 2N6044
R1		22	34-2N3643	Silicone NPN Transistor—Type 2N3643
R2-R5		10	19-808W4PO	4 ohm, $\pm$ 20%, 10W Special Wirewound Resistor
R7-R11, R13-R19, R23 R26		4	10-5102	1k ohm, $\pm$ 5%, 1/4W Carbon Composition Resistor
R27-R29		3	10-5417	470 ohm, $\pm$ 5%, 1/4W Carbon Composition Resistor
R30		7	10-5105	1M ohm, $\pm$ 5%, 1/4W Carbon Composition Resistor
R31, R32		3	10-5417	470 ohm, $\pm$ 5%, 1/4W Carbon Composition Resistor
R33		4	10-5102	1k ohm, $\pm$ 5%, 1/4W Carbon Composition Resistor
R34		6	10-5223	22k ohm, $\pm$ 5%, 1/4W Carbon Composition Resistor
R35		5	10-5822	8.2k ohm, $\pm$ 5%, 1/4W Carbon Composition Resistor
R36-R38		4	10-5102	1k ohm, $\pm$ 5%, 1/4W Carbon Composition Resistor
A1		23	37-7400	Quad 2-Input NAND Gate—Type 7400
A2		24	37-7402	Quad 2-Input NOR Gate—Type 7402
A3-A5		48	37-MC14050	Hex Buffer—Type MC14050
A3/4, A4/5		9	19-007	10k ohm Resistor Network

# Processor PCB A006020-11, -14, -15, and -16

# CABINET SUB-ASSEMBLY



DESIG-NATION	LOCA-TION	ITEM	PART NUMBER	DESCRIPTION
	A6-A11	37	37-7493	4-Bit Binary Counter—Type 7493
	A17-A20	47	37-MC1413	Darlington NPN Transistor Array—Type MC1413
	B2	29	37-7408	Quad 2-Input AND Gate—Type 7408
	B3	37	37-7493	4-Bit Binary Counter—Type 7493
	B4	42	37-9316	4-Bit Binary Counter—Type 9316
	B5	39	37-74157	Quad 2-Input Multiplexer—Type 74157
	B6	36	37-7474	Dual D Flip-Flop—Type 7474
	B7	33	37-7427	Triple 3-Input NOR Gate—Type 7427
	B8	32	37-7430	Dual 4-Input NAND Gate—Type 7420
	B9	36	37-7474	Dual D Flip-Flop—Type 7474
	B10	45	37-9602	Dual One-Shot Multivibrator—Type 9602
	B11	31	37-7414	Hex Schmitt Trigger—Type 7414
	B17-B20	47	37-MC1413	Darlington NPN Transistor Array—Type MC1413
	B/C8	30	37-74LS08	Quad 2-Input AND Gate—Type 74LS08
	C1	65	90-6001	Microprocessor—Type MC6800L
	C1	62	79-42040	Medium Insertion 40 Position Socket
	C4, C5	40	37-8090	Tri-State Hex Buffer—Type 8T97
	C6	41	37-9301	1-of-10 Decoder—Type 9301
	C7	24	37-7402	Quad 2-Input NOR Gate—Type 7402
	C8	34	37-7432	Quad 2-Input OR Gate—Type 7432
	C9	31	37-7414	Hex Schmitt Trigger—Type 7414
	C10	35	37-7437	Quad 2-Input NAND Buffer—Type 7437
	C11	37	37-7493	4-Bit Binary Counter—Type 7493
	C13-C20	44	37-9334	8-Bit Addressable Latch—Type 9334
	C/D8	30	37-74LS08	Quad 2-Input AND Gate—Type 74LS08
	D1	43	37-9321	Dual 1-of-4 Decoder—Type 9321
	D2, D3	29	37-7408	Quad 2-Input AND Gate—Type 7408
	D4	26	37-7404	Hex Inverter—Type 7404
	D5, D8	66	90-7015	Random Access Memory—Type 2111A
	D9	25	37-7403	Quad 2-Input NAND Gate (open collector)—Type 7403
	D10	23	37-7400	Quad 2-Input NAND Gate—Type 7400
	D11	27	37-74L04	Hex Inverter—Type 74L04
	D12	77	020252-01	Audio Random Access Memory
	D13	42	37-9316	4-Bit Binary Counter—Type 9316
	D14, D16, D18, D20	28	37-7407	Hex Buffer/Driver—Type 7407
PROGRAM MEMORY FOR PROCESSOR PCB 006020-15 ONLY				
	E00	68	020609-01	Read-Only-Memory
	E0	67	020608-01	Read-Only-Memory
PROGRAM MEMORY FOR PROCESSOR PCB A006020-11 ONLY				
	E1	69	020170-01	Read-Only-Memory—Address 7000-73FF, Bits 0-3
	E2	71	020171-01	Read-Only-Memory—Address 7400-77FF, Bits 0-3
	E3	75	020172-01	Read-Only-Memory—Address 7800-7FFF, Bits 0-3
	E4	73	020173-01	Read-Only-Memory—Address 7800-7AFF, Bits 0-3
	E5	74	020174-01	Read-Only-Memory—Address 7800-7AFF, Bits 4-7
	E6	76	020175-01	Read-Only-Memory—Address 7800-7FFF, Bits 4-7
	E7	70	020176-01	Read-Only-Memory—Address 7000-73FF, Bits 4-7
	E8	72	020177-01	Read-Only-Memory—Address 7400-77FF, Bits 4-7

DESIG-NATION	LOCA-TION	ITEM	PART NUMBER	DESCRIPTION
PROGRAM MEMORY FOR PROCESSOR PCB A006020-14 ONLY				
	E1	69	020460-01	Read-Only-Memory—Address 7000-73FF, Bits 0-3
	E2	71	020461-01	Read-Only-Memory—Address 7400-77FF, Bits 0-3
	E3	75	020462-01	Read-Only-Memory—Address 7800-7FFF, Bits 0-3
	E4	73	020463-01	Read-Only-Memory—Address 7800-7AFF, Bits 0-3
	E5	74	020464-01	Read-Only-Memory—Address 7800-7AFF, Bits 4-7
	E6	76	020465-01	Read-Only-Memory—Address 7800-7FFF, Bits 4-7
	E7	70	020466-01	Read-Only-Memory—Address 7000-73FF, Bits 4-7
	E8	72	020423-01	Read-Only-Memory—Address 7400-77FF, Bits 4-7
PROGRAM MEMORY FOR PROCESSOR PCB A006020-16 ONLY				
	E1	69	020644-01	Read-Only-Memory—Address 7000-73FF, Bits 0-3
	E2	71	020645-01	Read-Only-Memory—Address 7400-77FF, Bits 0-3
	E3	75	020646-01	Read-Only-Memory—Address 7800-7FFF, Bits 0-3
	E4	73	020647-01	Read-Only-Memory—Address 7800-7AFF, Bits 0-3
	E5	74	020648-01	Read-Only-Memory—Address 7800-7AFF, Bits 4-7
	E6	76	020649-01	Read-Only-Memory—Address 7800-7FFF, Bits 4-7
	E7	70	020650-01	Read-Only-Memory—Address 7000-73FF, Bits 4-7
	E8	72	020651-01	Read-Only-Memory—Address 7400-77FF, Bits 4-7
	E9	31	37-7414	Hex Schmitt Trigger—Type 7414
	E10	26	37-7404	Hex Inverter—Type 7404
	E11	41	37-9301	1-of-10 Decoder—Type 9301
	E12, E13	37	37-7493	Binary Counter—Type 7493
	F0, F1	80	37-74S00	Quad 2-Input NAND Gate—Type 74S00
	F2	52	66-118PIT	8 Position Dual-Inline-Package Switch—PROG SW1
	F3	38	37-74145	1-of-10 Decoder/Driver—Type 74145
	F4	52	66-118PIT	8 Position Dual-Inline-Package Switch—PROG SW2
	F5, F6, F9-F12	38	37-74145	1-of-10 Decoder/Driver—Type 74145
	REPLAY	53	66-12FPIT	Hex Switch
	RESET	51	62-001	SPST Pushbutton Switch
	Y1	64	90-108	4.000 MHz Crystal

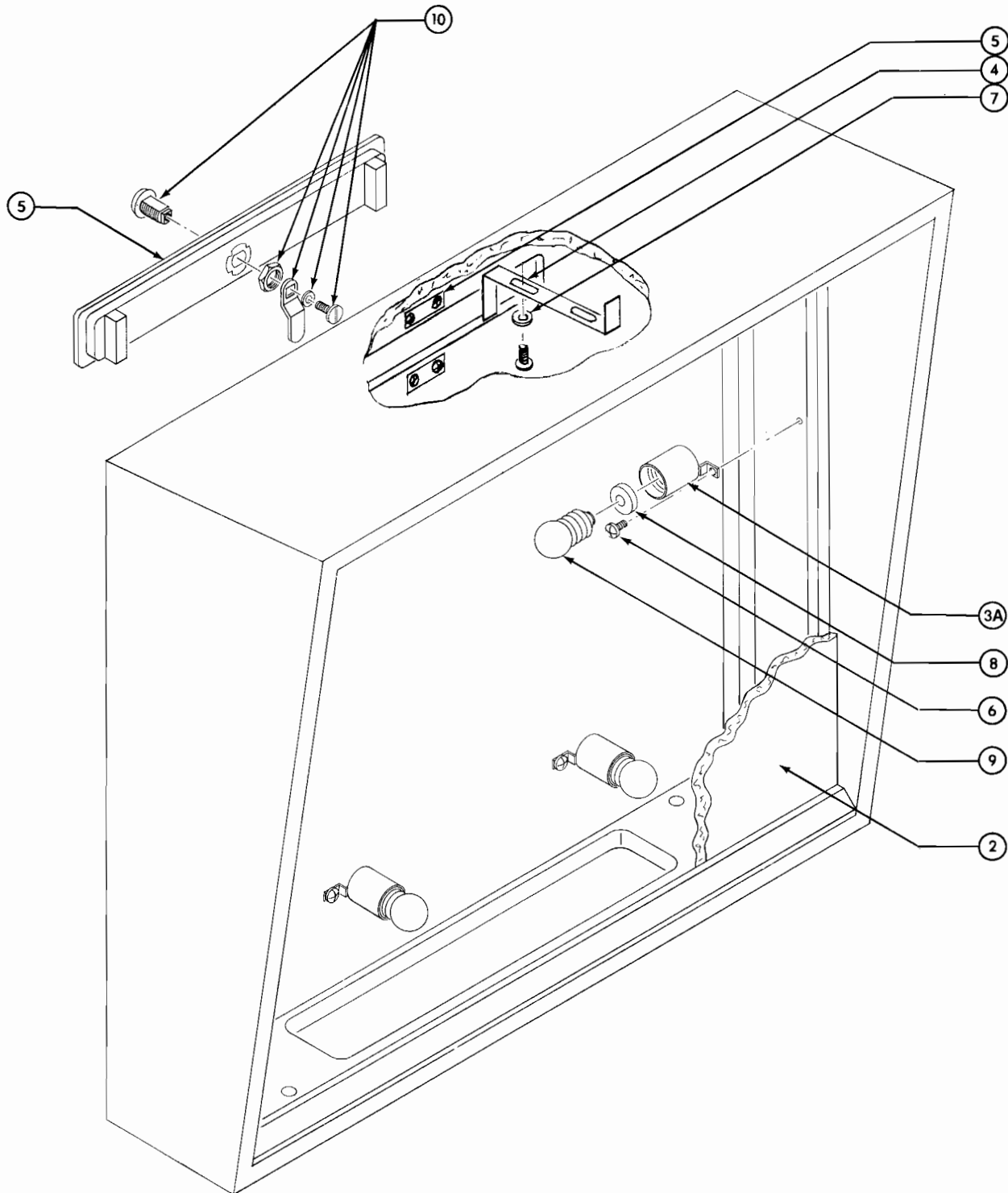

NOTICE TO ALL PERSONS RECEIVING THIS DRAWING  
CONFIDENTIAL: Reproduction forbidden without the  
specific written permission of Atari, Inc., Sunnyvale,  
California. This drawing is only conditionally issued, and  
neither receipt nor possession thereof confers or transfers  
any right in, or license to use, the subject matter of the  
drawing or any design or technical information shown  
thereon, nor any right to reproduce this drawing or any part  
thereof, except for manufacture by vendors of Atari, Inc.,  
incorporated and for manufacture under the corporation's writ-  
ten license, no right to reproduce this drawing is granted  
or the subject matter thereof unless by written agreement  
with or written permission from the corporation.

# BACK BOX ASSEMBLY

AIRBORNE AVENGER  
MIDDLE EARTH

A006986-01  
thru -04





**BACK BOX ASSEMBLY**  
 AIRBORNE AVENGER  
 MIDDLE EARTH

**BACK BOX ASSEMBLY**  
 THE ATARIANS  
 TIME 2000

A006986-01  
 thru -04

ITEM	PART NUMBER	QTY	DESCRIPTION	FOR MORE INFORMATION
2	A007845-01	1	Back Glass Assembly Used on The Atarians only	
	A007845-02	1	Back Glass Assembly Used on Time 2000 only	
	A007845-03	1	Back Glass Assembly Used on Airborne Avenger only	
	A007845-04	1	Back Glass Assembly Used on Middle Earth only	
3	A007867-01	1	Back Box Harness Assembly Not identified on drawing	
3A		5	Medium Screw Base Standard AC Utility Lamp Base—Part of Box Harness Assembly A007867-01	
4	006036-01	2	Glass Retainer	
5	006036-01	2	Lock Base Plate	
6	72-6608C	16	#6x1/2" Cross-Recessed Type AB Pan-Head Thread-Forming CRES Screw	
7	75-016S	6	#6 Regular Pattern Standard Plain Flat Steel Washer	
8	43-71600121	3	120V, 60W, Lamp Flasher Thermal Relay	
9	70-1617P5	5	105V, 7 1/2W, Medium Screw Base Standard AC Utility Soft-White Incandescent Lamp	
10	71-2117	1	Panel Cartridge Lock Hudson #CR73A569	



# PLAYFIELD ASSEMBLY

MIDDLE EARTH  
A020164-01

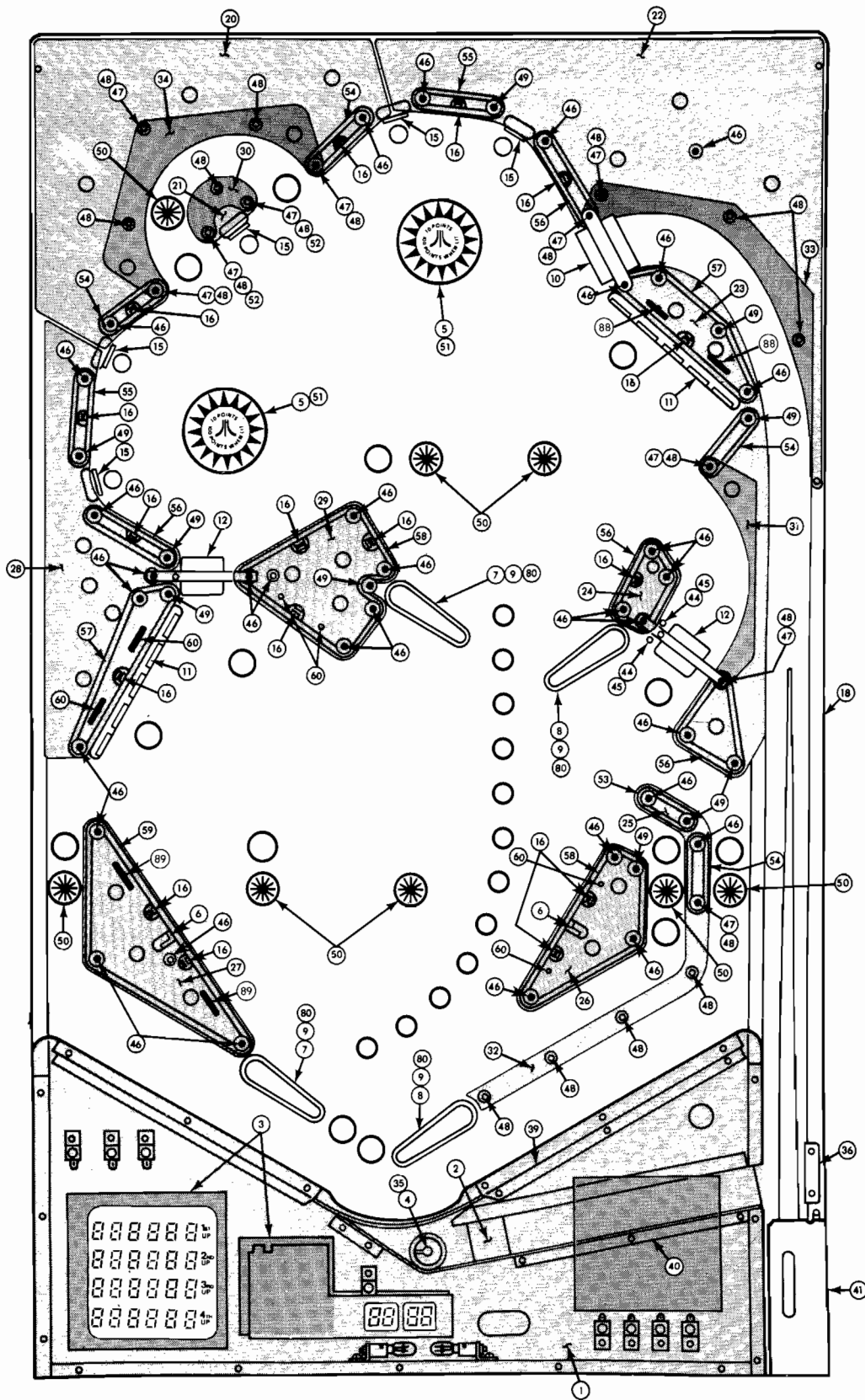

Middle Earth Playfield (top surface)

Item	Part Number	Qty	Description	For More Information
51	006066-02	2	RED POP BUMPER CAP	
52	006127-01	2	5/16" (DIA.) RUBBER RING	
53	006127-04	1	3/4" (DIA.) RUBBER RING	
54	006127-05	4	1" (DIA.) RUBBER RING	
55	006127-06	2	1 1/4" (DIA.) RUBBER RING	
56	006127-07	4	1 1/2" (DIA.) RUBBER RING	
57	006127-09	2	2 1/2" (DIA.) RUBBER RING	
58	006127-10	2	3" (DIA.) RUBBER RING	
59	006127-11	1	3 1/2" (DIA.) RUBBER RING	
60	74-A00001	4	1" X 1/4" X 5/32" I.D. WHITE NYLON SPACER	
75	70-11-47	75	MINIATURE LAMP, NEMA #47	
79	0020379-01	2	POP BUMPER RETAINING BRACKET	
80	006040-09	4	FLIPPER RUBBER RING	
88	004947-07	4	1 1/2" WIRE FORM	
89	004947-09	2	2" WIRE FORM	
90	020729-01	1	WIRE PROTECTION BRACKET	



# PLAYFIELD ASSEMBLY

MIDDLE EARTH  
A020164-01

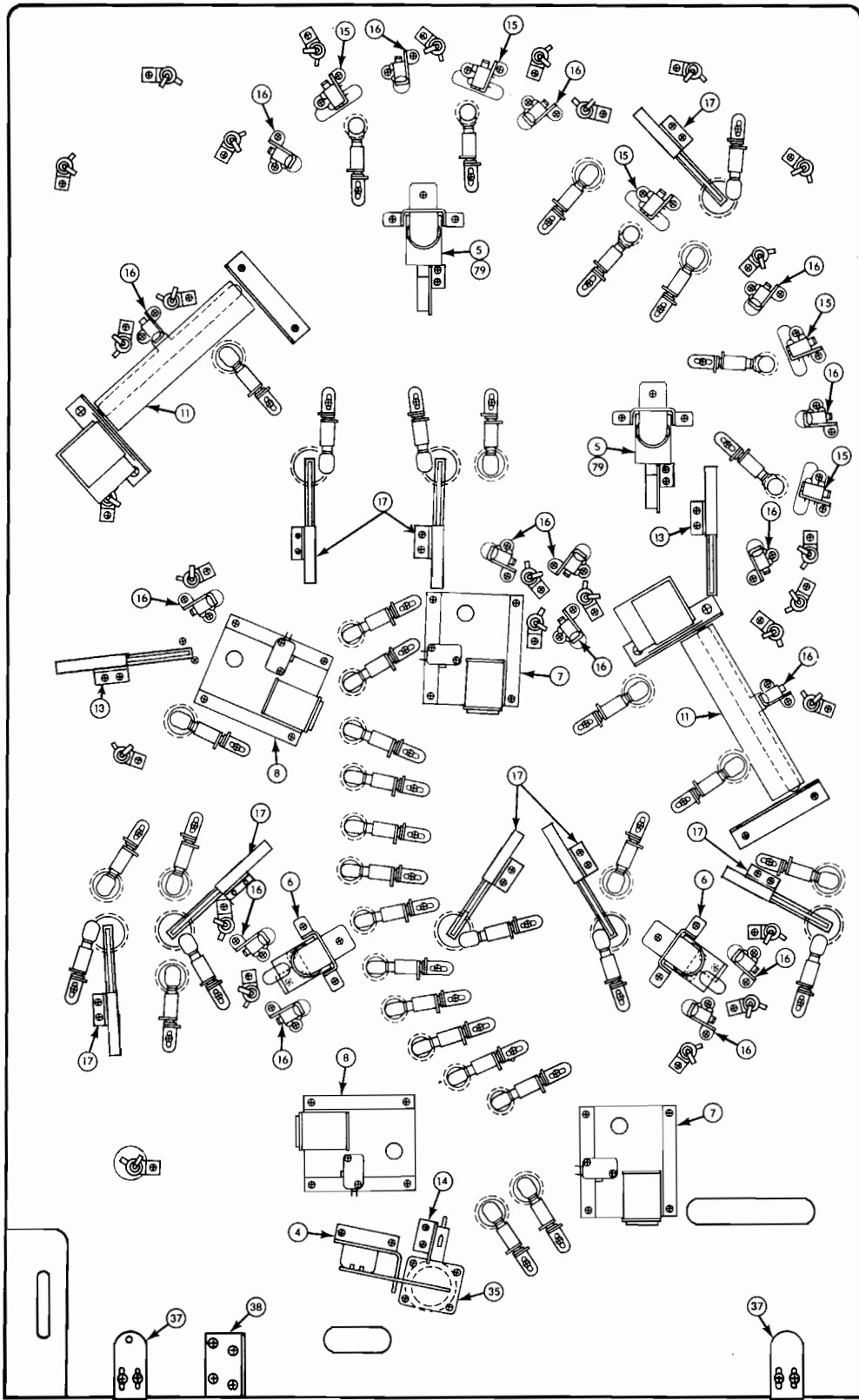

Middle Earth Playfield (underside)



# PLAYFIELD ASSEMBLY

MIDDLE EARTH  
A020164-01



# PLAYFIELD ASSEMBLY

## MIDDLE EARTH A020164-01

Item	Part Number	Qty	Description	For More Information
1	A007848-04	1	LOWER ARCH BUTYRATE	
2	A007833-01	1	BALL RETURN RAMP	See Section G, Sheet 97
3	A020732-01	1	SCORE DISPLAY	See Section G, Sheet 96C
4	A006067-01	1	KICK-OUT HOLE KICKER	See Section G, Sheet 4
5	A006049-01	2	THUMPER BUMPER	See Section G, Sheet 26
6	A006074-01	2	SLINGSHOT KICKER	See Section G, Sheet 12
7	A020400-01	2	LINEAR FLIPPER	See Section G, Sheet 33
8	A020400-02	2	LINEAR FLIPPER	See Section G, Sheet 33
10	A020314-01	1	BALL GATE	See Section G, Sheet 78
11	A020275-01	2	DROP TARGET	See Section G, Sheet 44
12	A020106-02	2	SPINNING TARGET	See Section G, Sheet 46
13	A030987-01	2	SPINNING TARGET SWITCH	See Section G, Sheet 46
14	A007877-01	1	KICK-OUT HOLE SWITCH	See Section G, Sheet 68
15	A020302-02	5	TARGET SWITCH	See Section G, Sheet 42
16	A020375-01	16	SWITCH AND BRACKET	See Section G, Sheet 67
17	A030983-01	8	ROLLOVER SWITCH	See Section G, Sheet 88
18	A020165-01	1	TOP RAIL	
19	A020230-02	1	MIDDLE EARTH PLAYFIELD HARNESS Not identified on drawing	
20	020229-01	1	UPPER LEFT BUTYRATE	
21	020229-02	1	LEFT CENTER BUTYRATE	
22	020229-03	1	UPPER RIGHT BUTYRATE	
23	020229-04	1	RIGHT DROP TARGET BUTYRATE	
24	020229-05	1	RIGHT SPINNING TARGET BUTYRATE	
25	020229-06	1	EXIT LANE BUTYRATE	
26	020229-07	1	RIGHT SLINGSHOT KICKER BUTYRATE	
27	020229-08	1	LEFT SLINGSHOT KICKER BUTYRATE	
28	020229-09	1	LEFT DROP TARGET BUTYRATE	
29	020229-10	1	LEFT SPINNING TARGET BUTYRATE	
30	020377-01	1	UPPER LEFT BALL GUIDE BUTYRATE	
31	020377-02	1	RIGHT SIDE RAIL BALL GUIDE BUTYRATE	
32	020337-03	1	FLIPPER RAIL BALL GUIDE BUTYRATE	
33	020377-04	1	ENTRANCE RAIL BALL GUIDE BUTYRATE	
34	020377-05	1	LOOP RAIL BALL GUIDE BUTYRATE	
35	004978-01	1	NYLON BALL HOLE	
36	007812-01	1	BALL RETURN SHIELD	
37	005952-01	2	PLAYFIELD INDEX PLATE	
38	005955-01	1	PLAYFIELD LOCKING BRACKET	
39	006749-01	1	LOWER ARCH SUPPORT	
40	006752-01	1	BALL GUIDE	
41	006772-01	1	BALL SHOOTER COVER	
44	020636-01	2	MINI POST	
45	99-080005	2	MINI POST RUBBER	
46	005985-09	33	WHITE LONG POST	
47	020359-09	10	WHITE BUTYRATE TOP POST	
48	020358-09	19	WHITE BUTYRATE BOTTOM POST	
49	005986-09	10	WHITE SHORT POST	
50	020040-10	8	BLACK TWIN STAR ROLLOVER ACTIVATOR	



# PLAYFIELD SUB-ASSEMBLY

Kick-Out Ball Hole Switch  
A006067-01

Section **G**  
Sheet 4

NOTICE TO ALL PERSONS RECEIVING THIS DRAWING CONFIDENTIAL. Reproduction forbidden without the specific written permission of Atari, Inc., Sunnyvale, California. This drawing is only conditionally issued, and neither receipt nor possession thereof confers or transfers any right in, or license to use, the subject matter of the drawing or any design or technical information shown thereon, nor any right to reproduce this drawing or any part thereof, except for manufacture by vendors of Atari, Incorporated and for manufacture under the corporation's written license, no right to reproduce this drawing is granted or the subject matter thereof unless by written agreement with or written permission from the corporation.

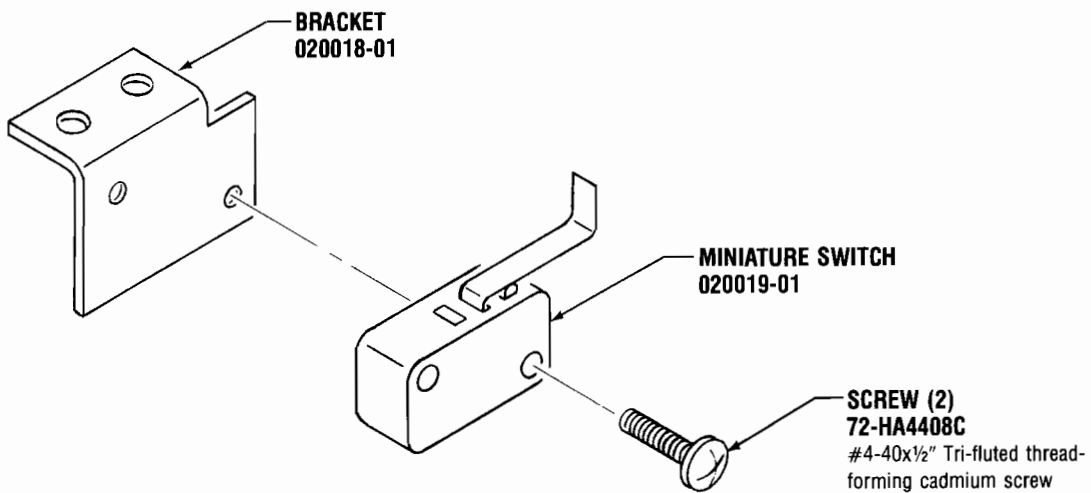

**NOTE:**

*THREAD-FORMING SCREWS MAY BE REPLACED BY NON-THREAD-FORMING MACHINE SCREWS.*

# PLAYFIELD SUB-ASSEMBLY

## SLINGSHOT KICKER A006074-01

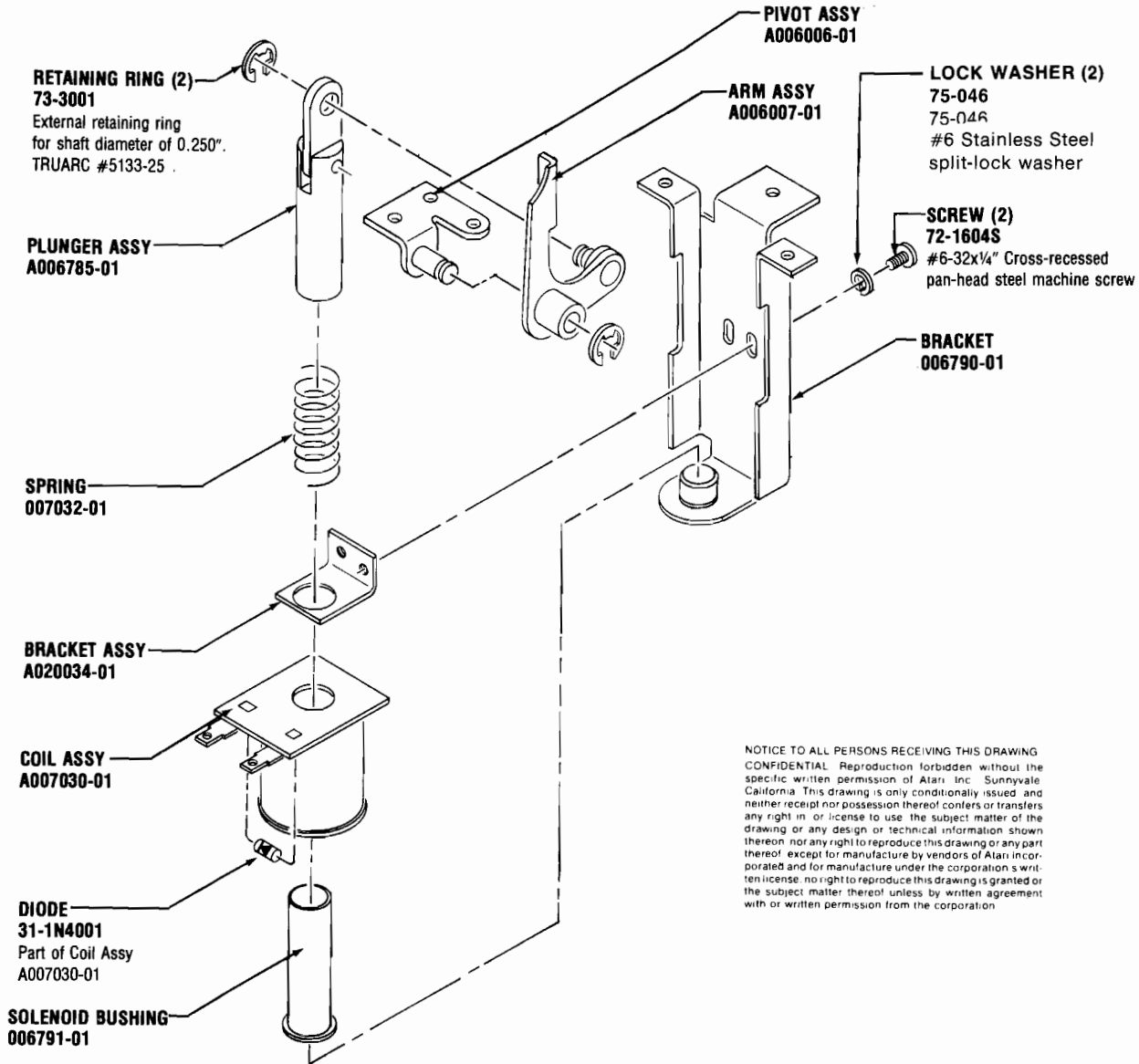

NOTICE TO ALL PERSONS RECEIVING THIS DRAWING  
CONFIDENTIAL. Reproduction forbidden without the  
specific written permission of Atari, Inc. Sunnyvale  
California. This drawing is only conditionally issued and  
neither receipt nor possession thereof confers or transfers  
any right in or license to use the subject matter of the  
drawing or any design or technical information shown  
thereon nor any right to reproduce this drawing or any part  
thereof except for manufacture by vendors of Atari incor-  
porated and for manufacture under the corporation's writ-  
ten license. No right to reproduce this drawing is granted or  
the subject matter thereof unless by written agreement  
with or written permission from the corporation.

NOTICE TO ALL PERSONS RECEIVING THIS DRAWING CONFIDENTIAL. Reproduction forbidden without the specific written permission of Atari, Inc., Sunnyvale, California. This drawing is only conditionally issued, and neither receipt nor possession thereof confers or transfers any right in, or license to use, the subject matter of the drawing or any design or technical information shown thereon, nor any right to reproduce this drawing or any part thereof, except for manufacture by vendors of Atari, Incorporated and for manufacture under the corporation's written license, no right to reproduce this drawing is granted or the subject matter thereof unless by written agreement with or written permission from the corporation.

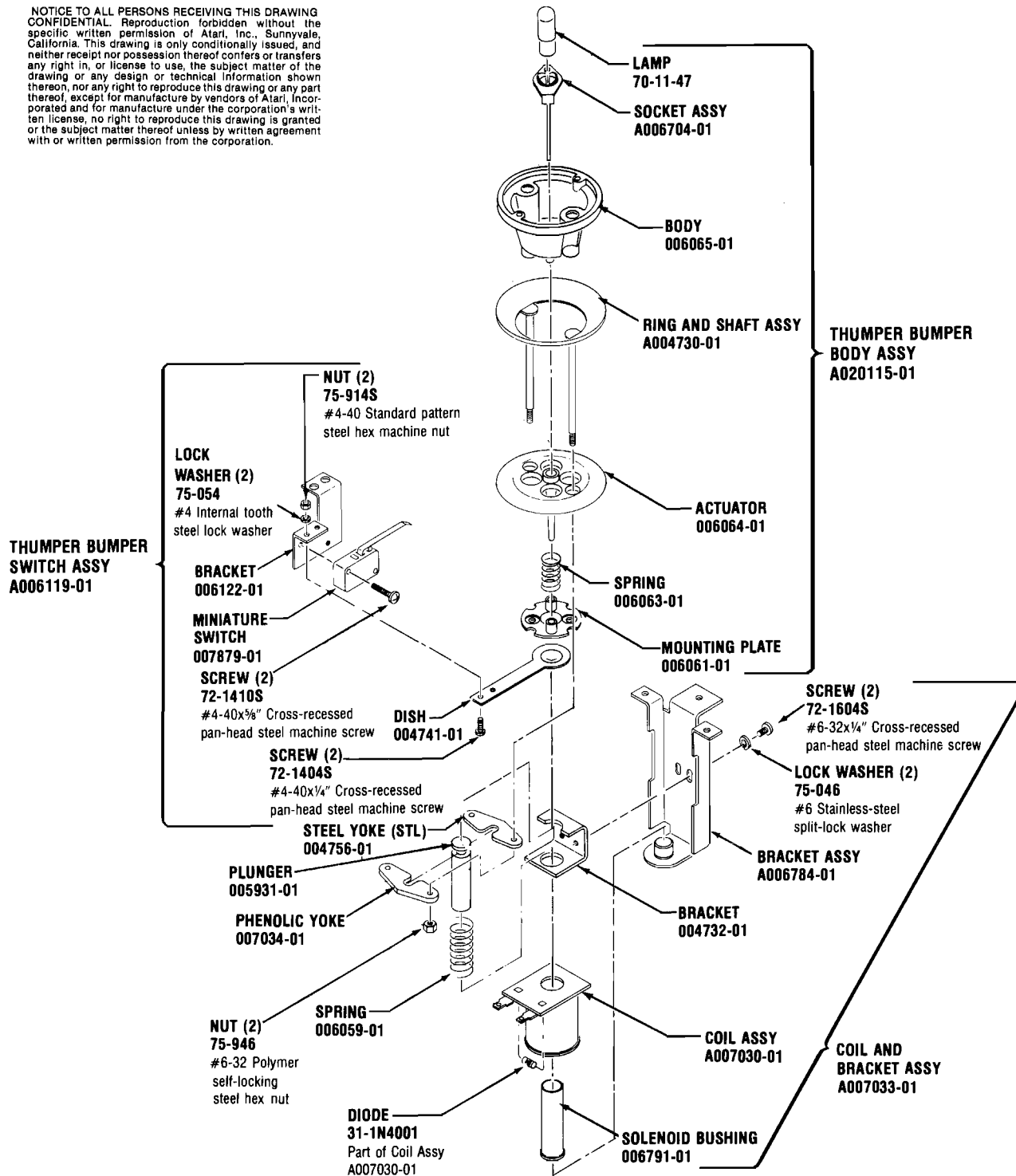

**NOTE:**

THREAD-FORMING SCREWS MAY BE REPLACED BY NON-THREAD-FORMING MACHINE SCREWS.



NOTICE TO ALL PERSONS RECEIVING THIS DRAWING  
 CONFIDENTIAL: Reproduction forbidden without the  
 specific written permission of Atari, Inc., Sunnyvale,  
 California. This drawing is only conditionally issued, and  
 neither receipt nor possession thereof confers or transfers  
 any right in, or license to use, the subject matter of the  
 drawing or any design or technical information shown  
 thereon, nor any right to reproduce this drawing or any part  
 thereof, except for manufacture by vendors of Atari, Incor-  
 porated and for manufacture under the corporation's writ-  
 ten license, no right to reproduce this drawing is granted  
 or the subject matter thereof unless by written agreement  
 with or written permission from the corporation.

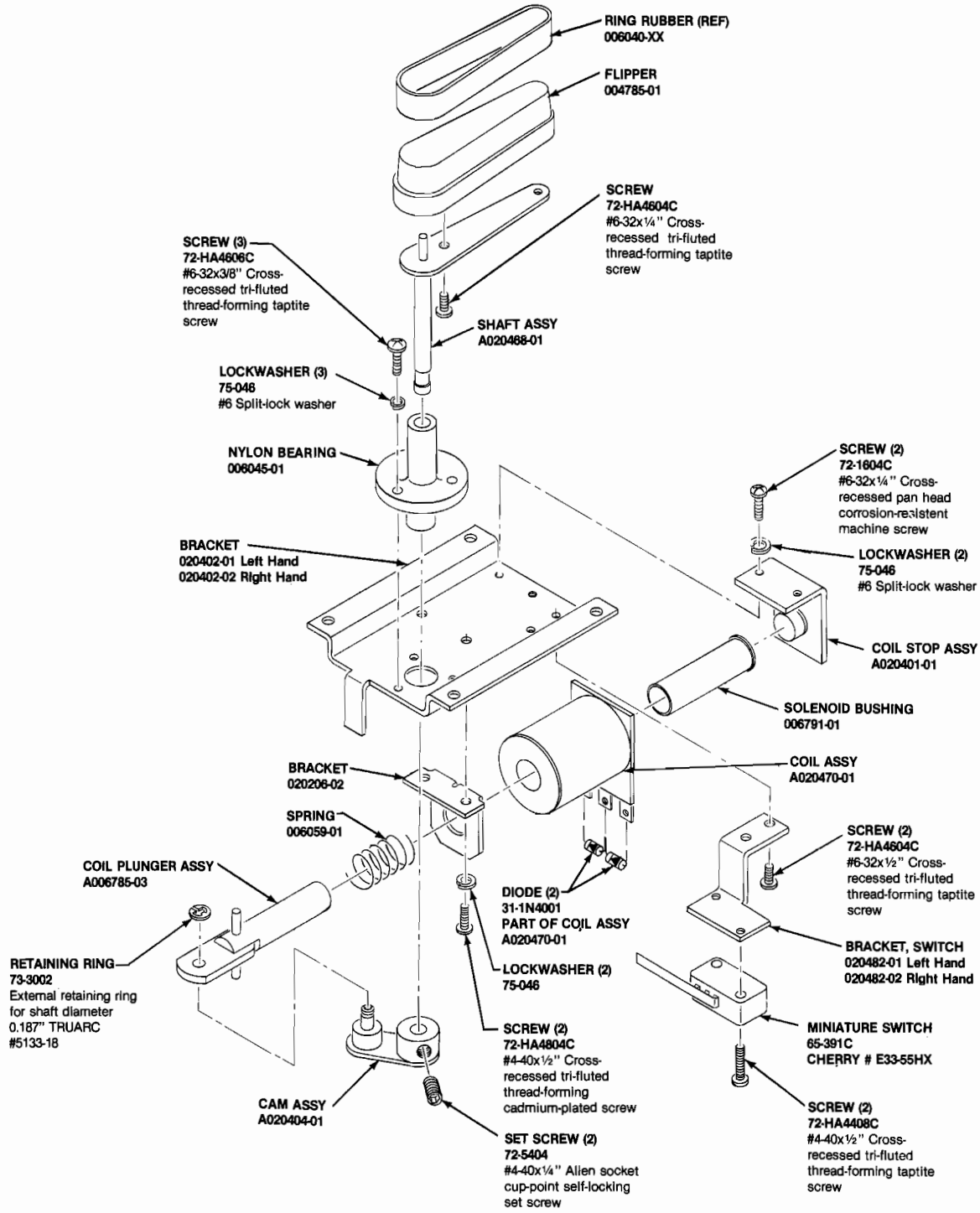

NOTE: A020400-01 LEFT HAND  
FLIPPER SHOWN

NOTICE TO ALL PERSONS RECEIVING THIS DRAWING  
 CONFIDENTIAL: Reproduction forbidden without the  
 specific written permission of Atari, Inc., Sunnyvale,  
 California. This drawing is the property of Atari, Inc.  
 neither receipt nor possession thereof confers or transfers  
 any right in, or license to use, the subject matter of the  
 drawing or any design or technical information shown  
 hereon, nor any right to reproduce this drawing or any part  
 thereof for any purpose other than that specifically au-  
 thorized and for manufacture under the corporation's writ-  
 ten license, no right to reproduce this drawing is granted  
 or the subject matter thereof unless by written agreement  
 with or written permission from the corporation.

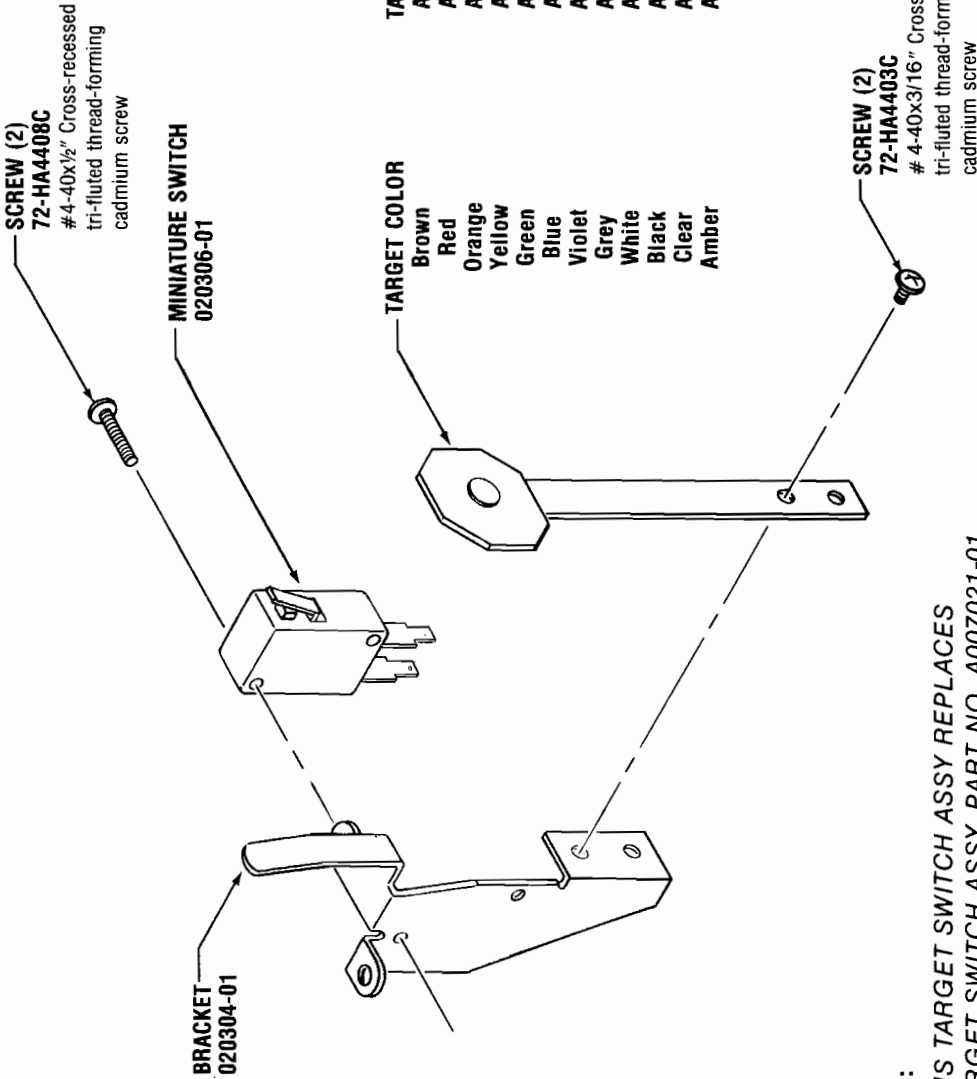

**NOTE:**

1. THIS TARGET SWITCH ASSY REPLACES  
 TARGET SWITCH ASSY, PART NO. A007021-01  
 THRU -04. SEE SHEET 41.
2. THREAD-FORMING SCREWS MAY BE REPLACED  
 BY NON-THREAD-FORMING MACHINE SCREWS.

TARGET SWITCH  
 A020302-02

**PLAYFIELD SUB-ASSEMBLY**



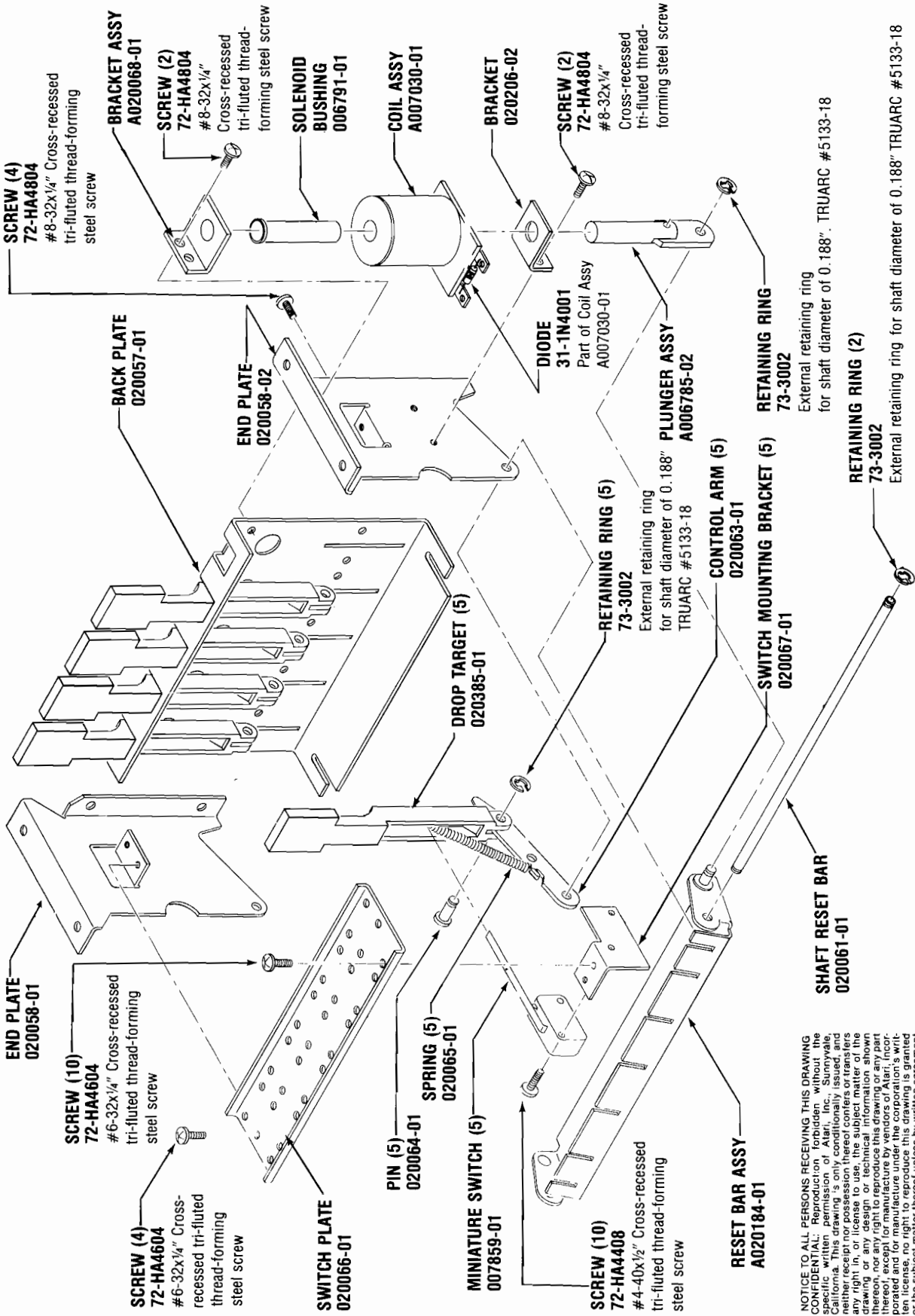

NOTICE TO ALL PERSONS RECEIVING THIS DRAWING  
 CONFIDENTIAL: Reproduction, forbidden without the  
 specific written permission of Atari, Inc., Sunnyvale,  
 California. This drawing is a trade secret of Atari,  
 and its disclosure, in whole or in part, to any person  
 without the written consent of Atari, Inc., is  
 strictly prohibited. This drawing is issued, and  
 neither receipt nor possession, theft, copying, or  
 any right in, or license to use, the subject matter of the  
 drawing, or any design or technical information shown  
 thereon, nor any right to reproduce this drawing or any part  
 thereof, except for manufacture by vendors of Atari, Inc.,  
 is hereby granted. No right to reproduce this drawing, or  
 license, no right to reproduce this drawing, is granted  
 or the subject matter thereof unless by written agreement  
 with or written permission from the corporation.

**DROP TARGET**  
A020275-01

**PLAYFIELD SUB-ASSEMBLY**



NOTICE TO ALL PERSONS RECEIVING THIS DRAWING  
 CONFIDENTIAL: Reproduction forbidden without the  
 specific written permission of Atari, Inc., Sunnyvale,  
 California. This drawing is only conditionally issued, and  
 neither receipt nor possession thereof confers or transfers  
 any right in, or license to use, the subject matter of the  
 drawing or any design or technical information shown  
 thereon, nor any right to reproduce this drawing or any part  
 thereof, except for manufacture by vendors of Atari, Incor-  
 porated and for manufacture under the corporation's writ-  
 ten license, no right to reproduce this drawing is granted  
 or the subject matter thereof unless by written agreement  
 with or written permission from the corporation.

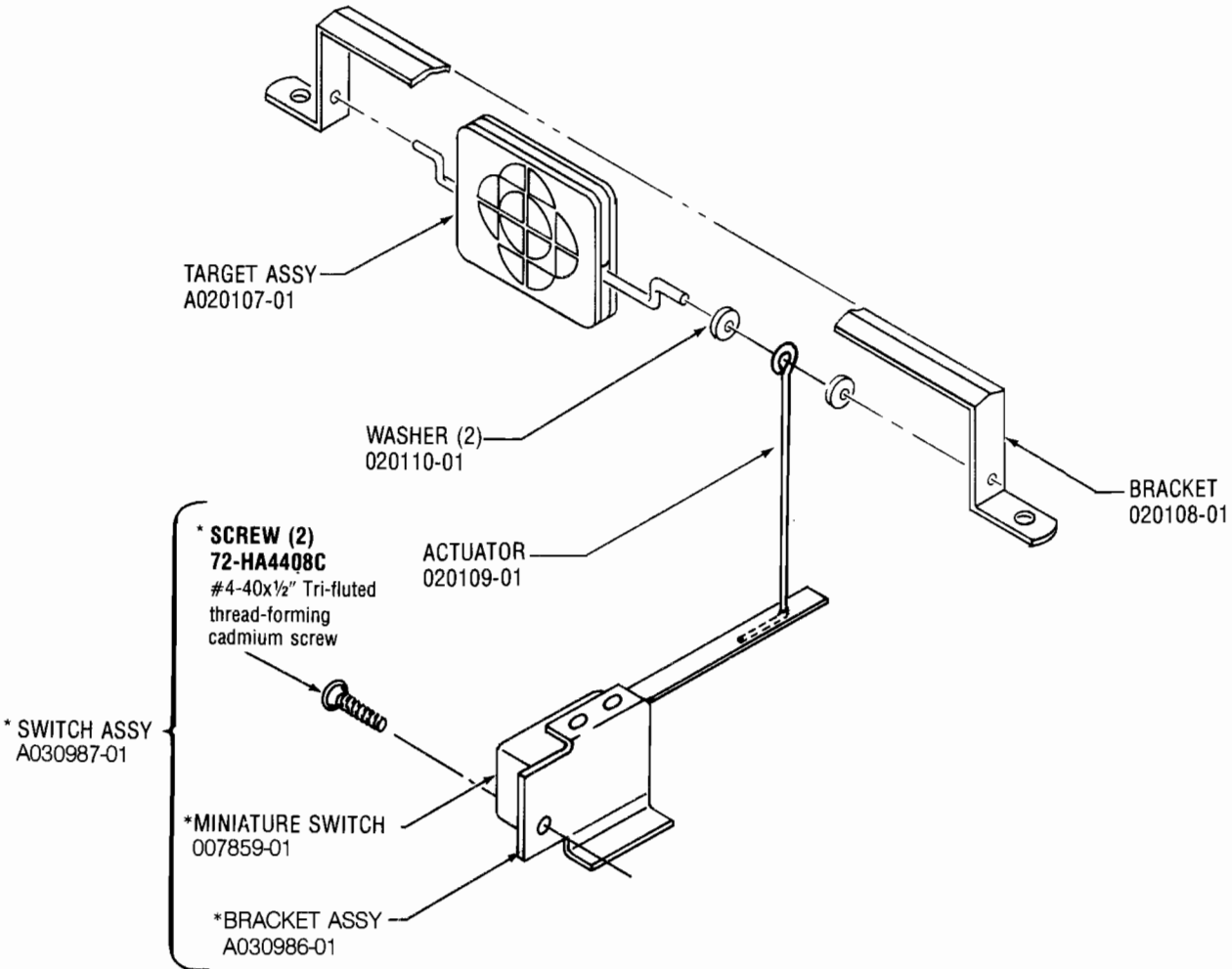

\*PART OF PLAYFIELD ASSY

**NOTE:**  
 THREAD-FORMING SCREWS MAY BE REPLACED  
 BY NON-THREAD-FORMING MACHINE SCREWS.



# PLAYFIELD SUB-ASSEMBLY

SPINNING TARGET  
 A020106-01

NOTICE TO ALL PERSONS RECEIVING THIS DRAWING  
CONFIDENTIAL: Reproduction forbidden without the  
specific written permission of Atari, Inc., Sunnyvale,  
California. This drawing is only conditionally issued, and  
neither receipt nor possession thereof confers or transfers  
any right in, or license to use, the subject matter of the  
drawing or any design or technical information shown  
thereon, nor any right to reproduce this drawing or any part  
thereof, except for manufacture by vendors of Atari, Incor-  
porated and for manufacture under the corporation's writ-  
ten license, no right to reproduce this drawing is granted  
or the subject matter thereof unless by written agreement  
with or written permission from the corporation.

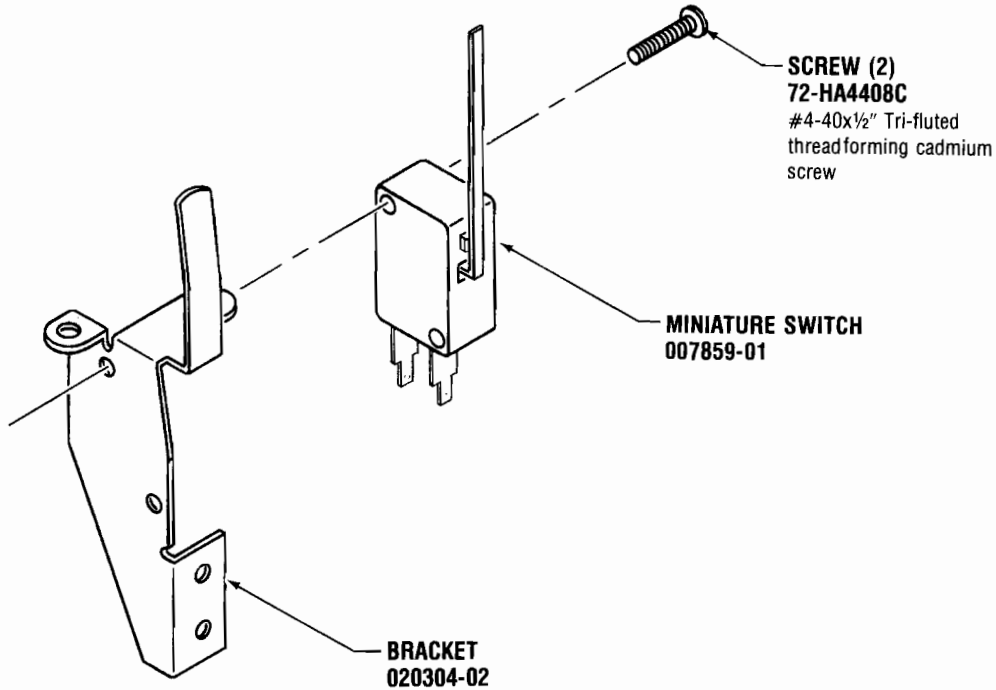

**NOTE:**

1. THIS SWITCH AND BRACKET ASSY  
REPLACES SWITCH AND BRACKET ASSY  
PART NO. A005024-01 THRU -04.  
**SEE SHEET 66.**
2. THREAD-FORMING SCREWS MAY BE REPLACED  
WITH NON-THREAD-FORMING MACHINE SCREWS.

ATARI®

PLAYFIELD SUB-ASSEMBLY

SWITCH AND BRACKET  
A020375-01

NOTICE TO ALL PERSONS RECEIVING THIS DRAWING  
 CONFIDENTIAL: Reproduction forbidden without the  
 specific written permission of Atari, Inc., Sunnyvale,  
 California. This drawing is only conditionally issued, and  
 neither receipt nor possession thereof confers or transfers  
 any right in, or license to use, the subject matter of the  
 drawing or any design or technical information shown  
 thereon, nor any right to reproduce this drawing or any part  
 thereof, except for manufacture by vendors of Atari incor-  
 porated and for manufacture under the corporation's writ-  
 ten license, no right to reproduce this drawing is granted or  
 the subject matter thereof unless by written agreement  
 with or written permission from the corporation.

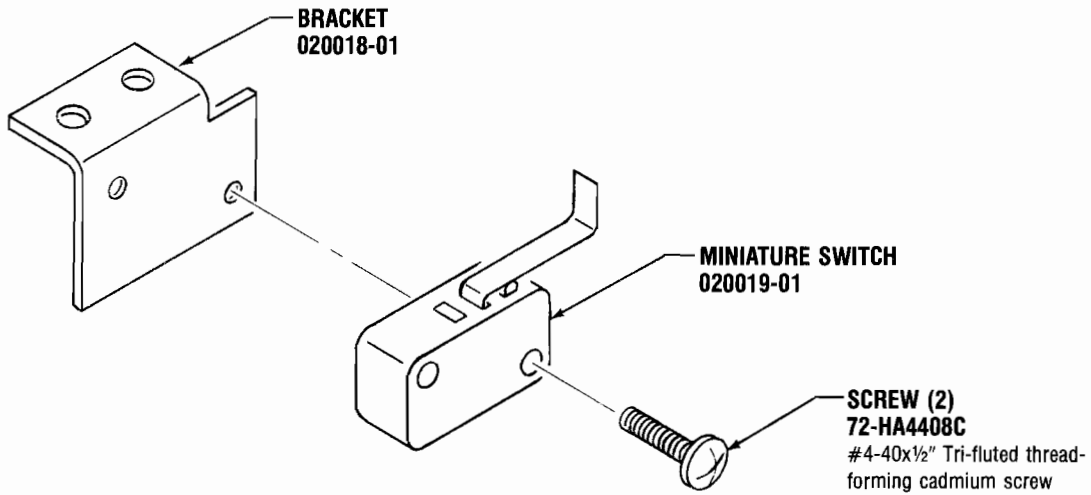

**NOTE:**

*THREAD-FORMING SCREWS MAY BE REPLACED  
 BY NON-THREAD-FORMING MACHINE SCREWS.*

**PLAYFIELD SUB-ASSEMBLY**

KICK-OUT BALL HOLE SWITCH  
 A007877-01

NOTICE TO ALL PERSONS RECEIVING THIS DRAWING  
CONFIDENTIAL: Reproduction forbidden without the  
specific written permission of Atari, Inc., Sunnyvale,  
California. This drawing is only conditionally issued, and  
neither receipt nor possession thereof confers or transfers  
any right in, or license to use, the subject matter of the  
drawing or any design or technical information shown  
thereon, nor any right to reproduce this drawing or any part  
thereof, except for manufacture by vendors of Atari, Incorporated and for manufacture under the corporation's written license, no right to reproduce this drawing is granted or the subject matter thereof unless by written agreement with or written permission from the corporation.

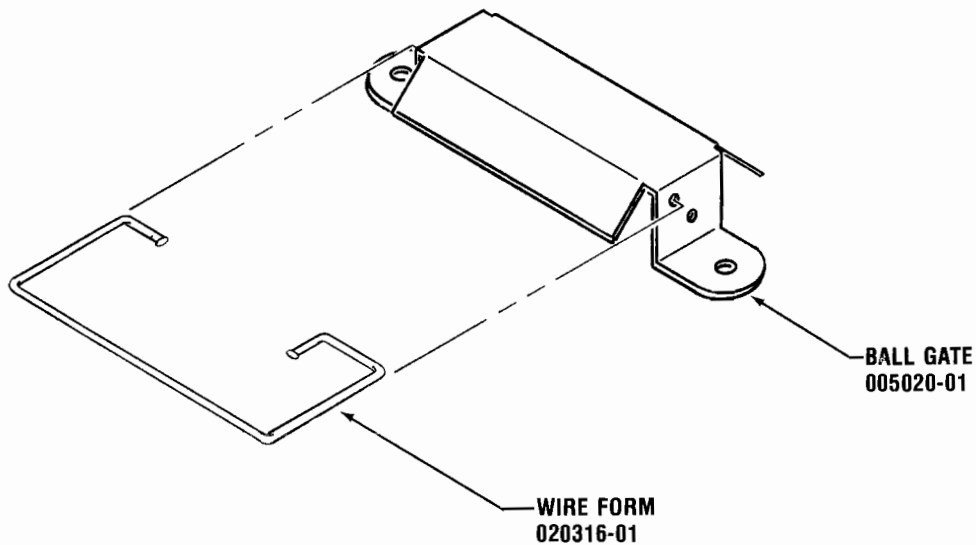

# PLAYFIELD SUB-ASSEMBLY

BALL GATE  
A020314-01

NOTICE TO ALL PERSONS RECEIVING THIS DRAWING  
**CONFIDENTIAL:** Reproduction forbidden without the  
 specific written permission of Atari, Inc., Sunnyvale,  
 California. This drawing is only conditionally issued, and  
 neither receipt nor possession thereof confers or transfers  
 any right in, or license to use, the subject matter of the  
 drawing or any design or technical information shown  
 thereon, nor any right to reproduce this drawing or any part  
 thereof, except for manufacture by vendors of Atari, Incor-  
 porated and for manufacture under the corporation's writ-  
 ten license, no right to reproduce this drawing is granted  
 or the subject matter thereof unless by written agreement  
 with or written permission from the corporation.

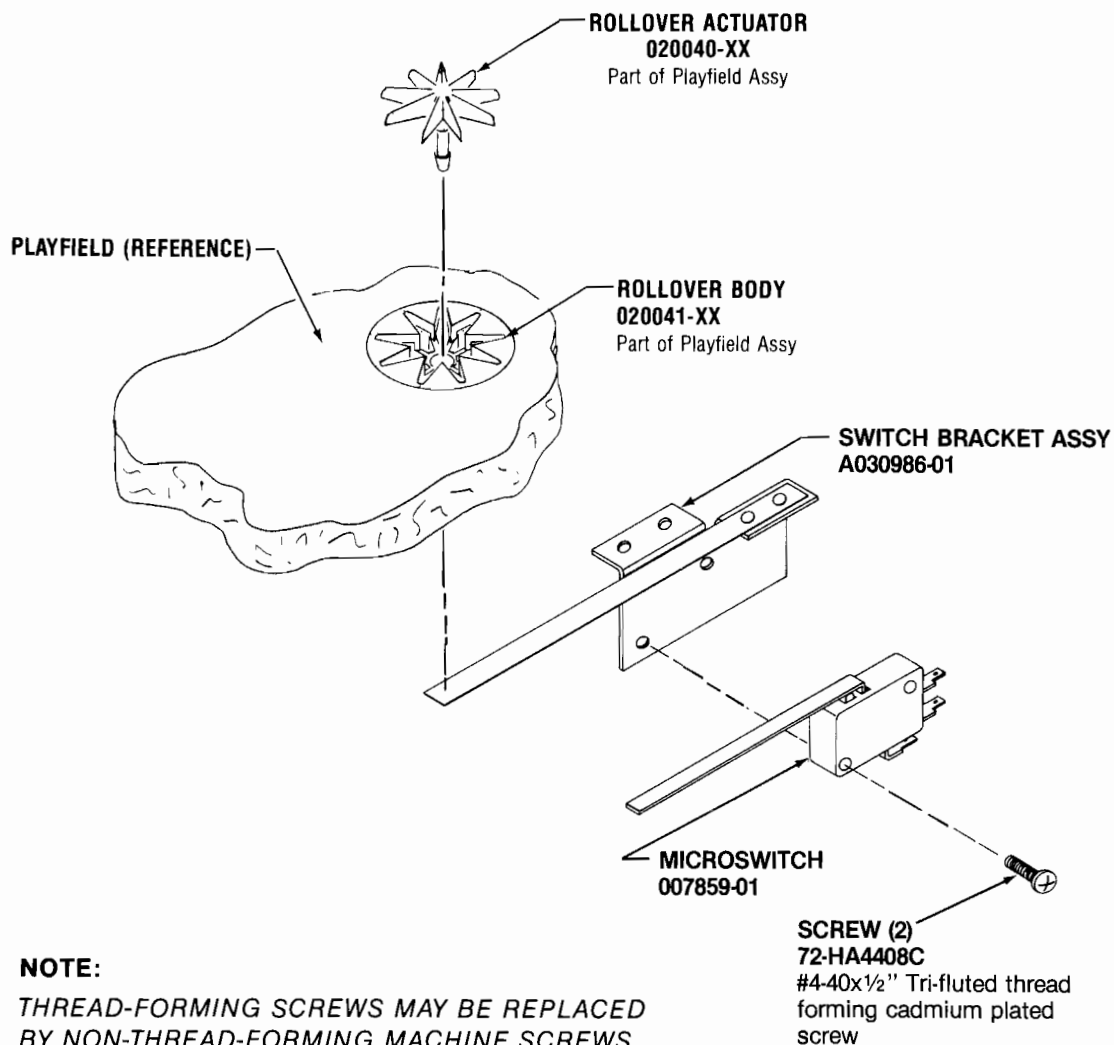

PART NUMBER		COLOR
TRANSPARENT	OPAQUE	
020040-01	020040-21	Brown
020040-02	020040-22	Red
020040-03	020040-23	Orange
020040-04	020040-24	Yellow
020040-05	020040-25	Green
020040-06	020040-26	Blue
020040-07	020040-27	Violet
020040-08	020040-28	Grey
020040-09	020040-29	White
020040-10	020040-30	Black
020040-11	020040-31	Clear
020040-13	020040-33	Amber





# PLAYFIELD SUB-ASSEMBLY

## SCORE DISPLAY A020732-01

NOTICE TO ALL PERSONS RECEIVING THIS DRAWING  
CONFIDENTIAL. Reproduction forbidden without the  
specific written permission of Atari, Inc., Sunnyvale,  
California. This drawing is only conditionally issued, and  
neither receipt nor possession thereof confers or transfers  
any right in, or license to use, the subject matter of the  
drawing or any design or technical information shown  
thereon, nor any right to reproduce this drawing or any part  
thereof, except for manufacture by vendors of Atari Incorporated  
and for manufacture under the corporation's written  
license. No right to reproduce this drawing is granted or  
the subject matter thereof unless by written agreement  
with or written permission from the corporation.

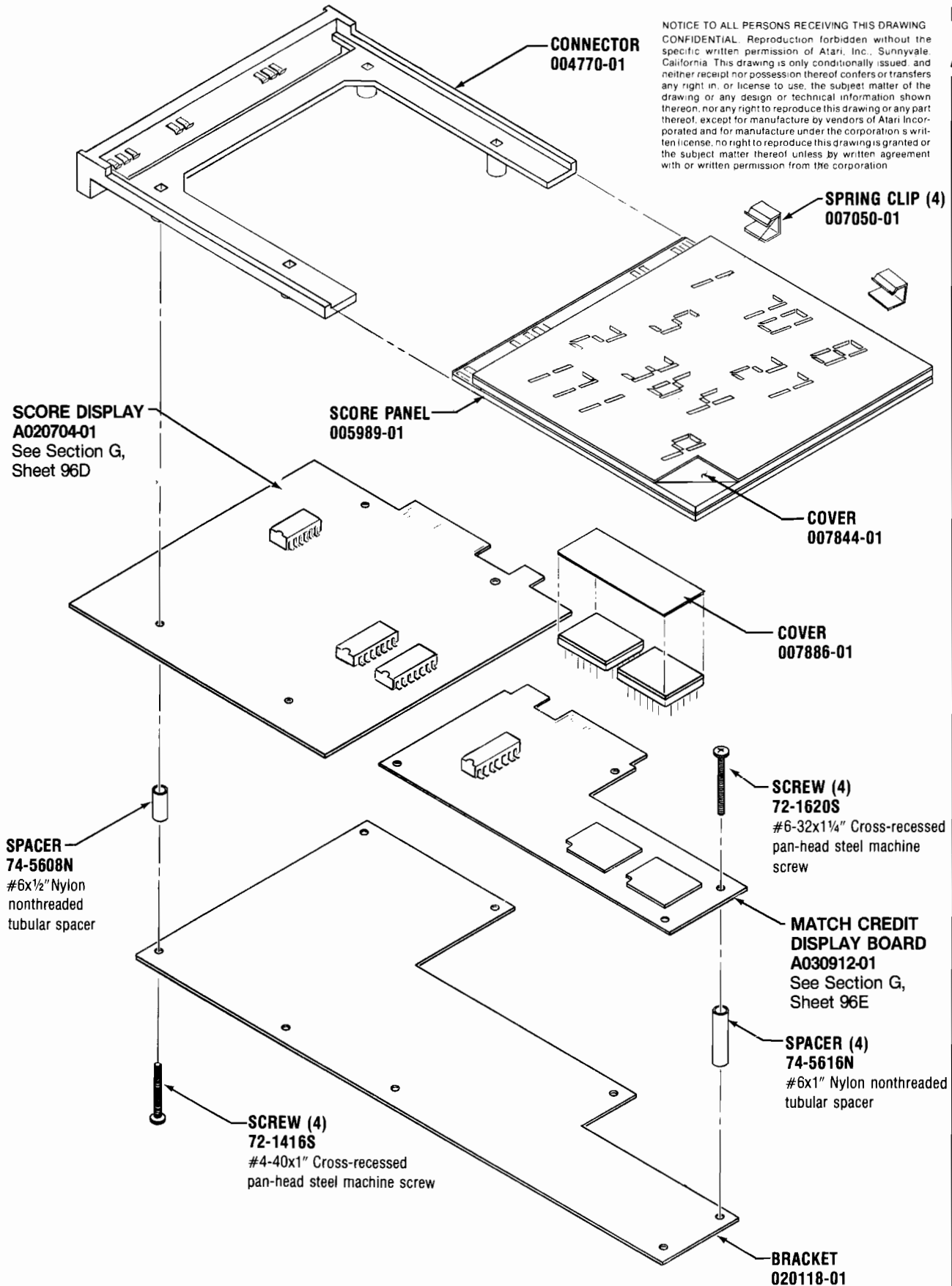

NOTICE TO ALL PERSONS RECEIVING THIS DRAWING  
 CONFIDENTIAL: Reproduction forbidden without the  
 specific written permission of Atari, Inc., Sunnyvale,  
 California. This drawing is only conditionally issued, and  
 neither receipt nor possession thereof confers or transfers  
 any right in, or license to use, the subject matter of the  
 drawing or any design or technical information shown  
 thereon, nor any right to reproduce this drawing or any part  
 thereof, except for manufacture by vendors of Atari, Incor-  
 porated and for manufacture under the corporation's writ-  
 ten license, no right to reproduce this drawing is granted  
 or the subject matter thereof unless by written agreement  
 with or written permission from the corporation.

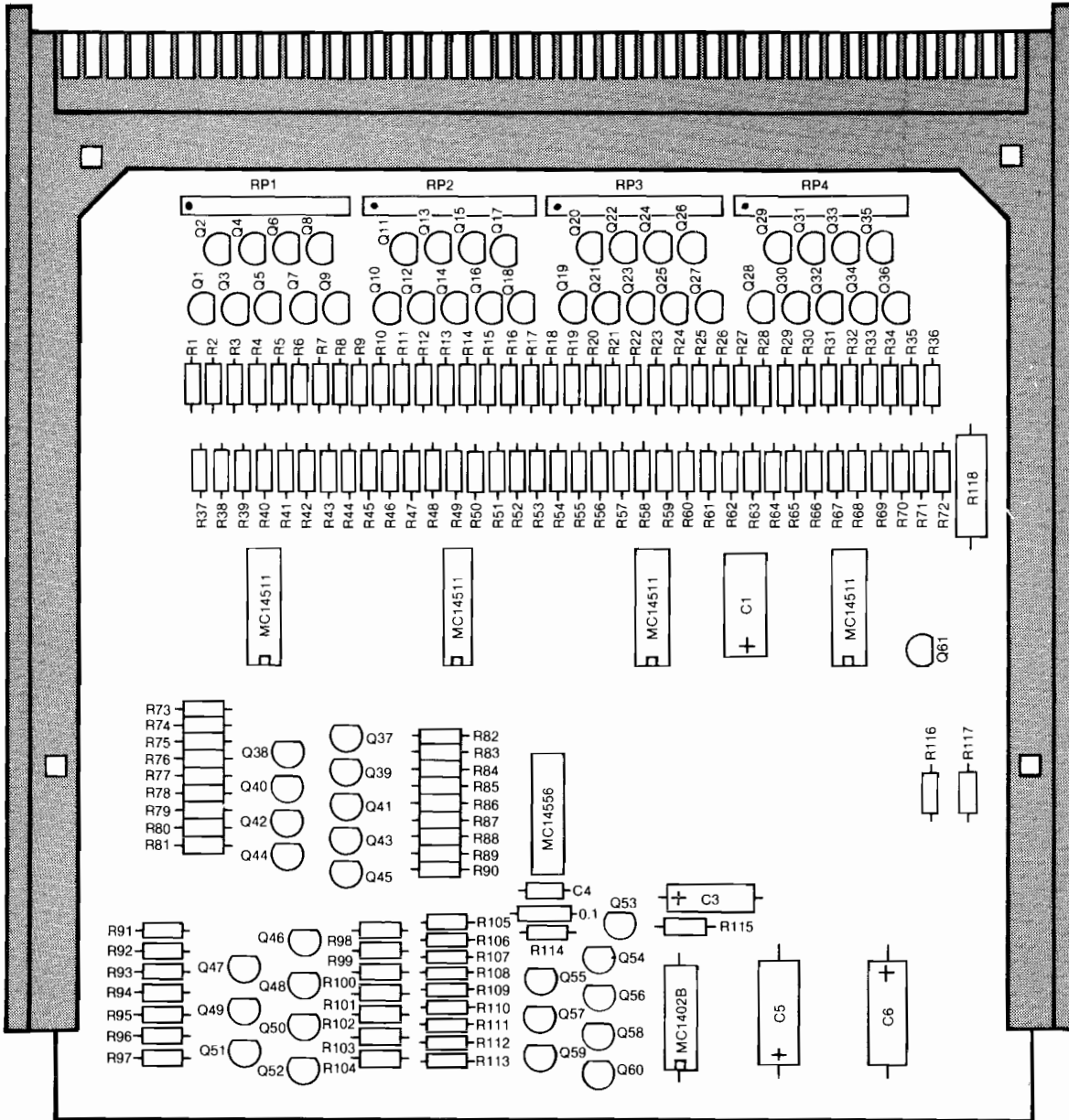

# PLAYFIELD SUB-ASSEMBLY

Score Display Drive PCB  
 A020704-01



# PLAYFIELD SUB-ASSEMBLY

SCORE DISPLAY DRIVE  
A020704-01

Section  
Sheet 96D

DESIG-NATION	LOCA-TION	ITEM	PART NUMBER	DESCRIPTION
C1		19	24-250107	100 mf, -10%, +50%, 25 WVDC Axial Lead Electrolytic Capacitor
C2		20	24-250104	0.1 mf, -10%, +75%, 25 WVDC Axial Lead Electrolytic Capacitor
C3		17	24-250106	10 mf, -10%, +50%, 25 WVDC Axial Lead Electrolytic Capacitor
C4		20	24-250104	0.1 mf, -10%, +75%, 25 WVDC Axial Lead Electrolytic Capacitor
C5,C6		18	24-101106	10 mf, -10%, +50%, 100 WVDC Axial Lead Electrolytic Capacitor
Q1-Q36		23	34-MPSA42	High Speed NPN General Purpose Amplifier — Motorola #MPSA42B
Q37-Q52		24	33-MPSA92	High Speed PNP General Purpose Amplifier — Motorola #MPSA92B
Q53-Q61		23	34-MPSA42	High Speed NPN General Purpose Amplifier — Motorola #MPSA42B
R1		3	10-5471	470 ohm, ±5%, 1/4W Carbon Composition Resistor
R2		6	10-5432	4.3k ohm, ±5%, 1/4W Carbon Composition Resistor
R3-R5		4	10-5222	2.2k ohm, ±5%, 1/4W Carbon Composition Resistor
R6		6	10-5432	4.3k ohm, ±5%, 1/4W Carbon Composition Resistor
R7		4	10-5222	2.2k ohm, ±5%, 1/4W Carbon Composition Resistor
R8		6	10-5432	4.3k ohm, ±5%, 1/4W Carbon Composition Resistor
R9,R10		3	10-5471	470 ohm, ±5%, 1/4W Carbon Composition Resistor
R11		6	10-5432	4.3k ohm, ±5%, 1/4W Carbon Composition Resistor
R12-R14		4	10-5222	2.2k ohm, ±5%, 1/4W Carbon Composition Resistor
R15		6	10-5432	4.3k ohm, ±5%, 1/4W Carbon Composition Resistor
R16		4	10-5222	2.2k ohm, ±5%, 1/4W Carbon Composition Resistor
R17		6	10-5432	4.3k ohm, ±5%, 1/4W Carbon Composition Resistor
R18,R19		3	10-5471	470 ohm, ±5%, 1/4W Carbon Composition Resistor
R20		6	10-5432	4.3k ohm, ±5%, 1/4W Carbon Composition Resistor
R21-R23		4	10-5222	2.2k ohm, ±5%, 1/4W Carbon Composition Resistor
R24		6	10-5432	4.3k ohm, ±5%, 1/4W Carbon Composition Resistor
R25		4	10-5222	2.2k ohm, ±5%, 1/4W Carbon Composition Resistor
R26		6	10-5432	4.3k ohm, ±5%, 1/4W Carbon Composition Resistor
R27,R28		3	10-5471	470 ohm, ±5%, 1/4W Carbon Composition Resistor
R29		6	10-5432	4.3k ohm, ±5%, 1/4W Carbon Composition Resistor
R30-R32		4	10-5222	2.2k ohm, ±5%, 1/4W Carbon Composition Resistor
R33		6	10-5432	4.3k ohm, ±5%, 1/4W Carbon Composition Resistor
R34		4	10-5222	2.2k ohm, ±5%, 1/4W Carbon Composition Resistor
R35		6	10-5432	4.3k ohm, ±5%, 1/4W Carbon Composition Resistor
R36		3	10-5471	470 ohm, ±5%, 1/4W Carbon Composition Resistor
R37		4	10-5222	2.2k ohm, ±5%, 1/4W Carbon Composition Resistor
R38		9	10-5153	15k ohm, ±5%, 1/4W Carbon Composition Resistor
R39-R41		7	10-5822	8.2k ohm, ±5%, 1/4W Carbon Composition Resistor
R42		9	10-5153	15k ohm, ±5%, 1/4W Carbon Composition Resistor
R43		7	10-5822	8.2k ohm, ±5%, 1/4W Carbon Composition Resistor
R44		4	10-5222	2.2k ohm, ±5%, 1/4W Carbon Composition Resistor
R45		9	10-5143	15k ohm, ±5%, 1/4W Carbon Composition Resistor
R46		4	10-5222	2.2k ohm, ±5%, 1/4W Carbon Composition Resistor
R47		9	10-5153	15k ohm, ±5%, 1/4W Carbon Composition Resistor
R48-R50		7	10-5822	8.2k ohm, ±5%, 1/4W Carbon Composition Resistor

NOTICE TO ALL PERSONS RECEIVING THIS DRAWING  
 CONFIDENTIAL: Reproduction, without the  
 specific written permission of Atari, Inc.,  
 is prohibited. This drawing is only conditionally issued, and  
 neither receipt nor possession thereof confers or transfers  
 any right in, or license to use, the subject matter of the  
 drawing or any design or technical information shown  
 thereon, nor any right to reproduce this drawing or any part  
 thereof, in whole or in part, for any purpose other than  
 that intended and for manufacture under the corporation's writ-  
 ten license, no right to reproduce this drawing is granted  
 or the subject matter thereof unless by written agreement  
 with or written permission from the corporation.

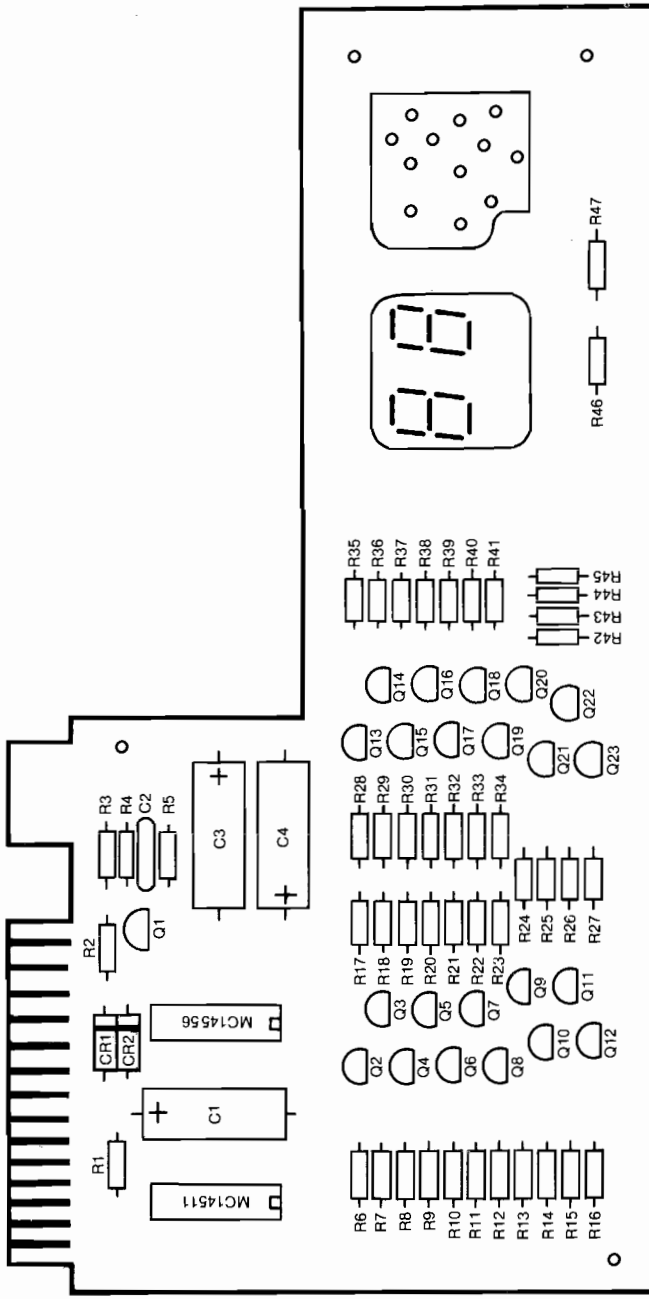

# PLAYFIELD SUB-ASSEMBLY

Match/Credit PCB  
 A030912-01



# PLAYFIELD SUB-ASSEMBLY

Match/Credit PCB  
A030912-01

Section **G**  
Sheet 96E

DESIG-NATION	LOCA-TION	ITEM	PART NUMBER	DESCRIPTION
C1		11	24-250226	22 $\mu$ f, + 10%, -50%, 25 WVDC Axial Lead Electrolytic Capacitor
C2		13	29-005	0.1 $\mu$ f Monolithic Ceramic Capacitor
C3,C4		12	25-101106	10 $\mu$ f, + 10%, -50%, 100 WVDC Axial Lead Electrolytic Capacitor
CR1,CR2		16	31-1N914	General Purpose Silicon Diode — Type 1N914
Q1		20	34-MPSA42	High Speed NPN General Purpose Amplifier — Motorola #MPSA42B
Q2-Q8		21	33-MPSA92	High Speed PNP General Purpose Amplifier — Motorola #MPSA92B
Q9-Q19		20	34-MPSA42	High Speed NPN General Purpose Amplifier — Motorola #MPSA42B
Q20-Q23		21	33-MPSA92	High Speed PNP General Purpose Amplifier — Motorola #MPSA92B
R1,R2		6	10-5104	100k ohm, $\pm$ 5%, 1/4 W Carbon Composition Resistor
R3		5	10-5473	47k ohm, $\pm$ 5%, 1/4 W Carbon Composition Resistor
R4		3	10-5332	3.3k ohm, $\pm$ 5%, 1/4 W Carbon Composition Resistor
R5		5	10-5473	47k ohm, $\pm$ 5%, 1/4 W Carbon Composition Resistor
R6-R27		4	10-5103	10k ohm, $\pm$ 5%, 1/4 W Carbon Composition Resistor
R28-R34		2	10-5272	2.7k ohm, $\pm$ 5%, 1/4 W Carbon Composition Resistor
R35-R41		7	10-5105	1M ohm, $\pm$ 5%, 1/4 W Carbon Composition Resistor
R42-R45		6	10-5104	100k ohm, $\pm$ 5%, 1/4 W Carbon Composition Resistor
R46,R47		8	10-5155	1.5M ohm, $\pm$ 5%, 1/4 W Carbon Composition Resistor
		28	94-14SP-352	Two-Digit Gas-Discharge Display - BECKMAN #SP-352. Used for displaying MATCH and CREDIT numbers.
		27	79-41001	Two-Digit Display Socket - BECKMAN #CS-352



# PLAYFIELD SUB-ASSEMBLY

DESIG-NATION	LOCA-TION	ITEM	PART NUMBER	DESCRIPTION
R51		9	10-5153	15k ohm, $\pm 5\%$ , $\frac{1}{4}$ W Carbon Composition Resistor
R52		7	10-5822	8.2k ohm, $\pm 5\%$ , $\frac{1}{4}$ W Carbon Composition Resistor
R53		4	10-5222	2.2k ohm, $\pm 5\%$ , $\frac{1}{4}$ W Carbon Composition Resistor
R54		9	10-5153	15k ohm, $\pm 5\%$ , $\frac{1}{4}$ W Carbon Composition Resistor
R55		4	10-5222	2.2k ohm, $\pm 5\%$ , $\frac{1}{4}$ W Carbon Composition Resistor
R56		9	10-5153	15k ohm, $\pm 5\%$ , $\frac{1}{4}$ W Carbon Composition Resistor
R57-R59		7	10-5822	8.2k ohm, $\pm 5\%$ , $\frac{1}{4}$ W Carbon Composition Resistor
R60		9	10-5153	15k ohm, $\pm 5\%$ , $\frac{1}{4}$ W Carbon Composition Resistor
R61		7	10-5822	8.2k ohm, $\pm 5\%$ , $\frac{1}{4}$ W Carbon Composition Resistor
R62		4	10-5222	2.2k ohm, $\pm 5\%$ , $\frac{1}{4}$ W Carbon Composition Resistor
R63		9	10-5153	15k ohm, $\pm 5\%$ , $\frac{1}{4}$ W Carbon Composition Resistor
R64		4	10-5222	2.2k ohm, $\pm 5\%$ , $\frac{1}{4}$ W Carbon Composition Resistor
R65		9	10-5153	15k ohm, $\pm 5\%$ , $\frac{1}{4}$ W Carbon Composition Resistor
R66-R68		7	10-5822	8.2k ohm, $\pm 5\%$ , $\frac{1}{4}$ W Carbon Composition Resistor
R69		9	10-5153	15k ohm, $\pm 5\%$ , $\frac{1}{4}$ W Carbon Composition Resistor
R70		7	10-5822	8.2k ohm, $\pm 5\%$ , $\frac{1}{4}$ W Carbon Composition Resistor
R71		4	10-5222	2.2k ohm, $\pm 5\%$ , $\frac{1}{4}$ W Carbon Composition Resistor
R72		9	10-5153	15k ohm, $\pm 5\%$ , $\frac{1}{4}$ W Carbon Composition Resistor
R73-R90		10	10-5223	2.2k ohm, $\pm 5\%$ , $\frac{1}{4}$ W Carbon Composition Resistor
R91-R97		8	10-5103	10k ohm, $\pm 5\%$ , $\frac{1}{4}$ W Carbon Composition Resistor
R98-R104		2	10-5121	120 ohm, $\pm 5\%$ , $\frac{1}{4}$ W Carbon Composition Resistor
R105		10	10-5223	22k ohm, $\pm 5\%$ , $\frac{1}{4}$ W Carbon Composition Resistor
R106		11	10-5473	47k ohm, $\pm 5\%$ , $\frac{1}{4}$ W Carbon Composition Resistor
R107-R113		8	10-5103	10k ohm, $\pm 5\%$ , $\frac{1}{4}$ W Carbon Composition Resistor
R114		5	10-5332	3.3k ohm, $\pm 5\%$ , $\frac{1}{4}$ W Carbon Composition Resistor
R115		10	10-5223	22k ohm, $\pm 5\%$ , $\frac{1}{4}$ W Carbon Composition Resistor
R116		5	10-5332	3.3k ohm, $\pm 5\%$ , $\frac{1}{4}$ W Carbon Composition Resistor
R117		11	10-5473	47k ohm, $\pm 5\%$ , $\frac{1}{4}$ W Carbon Composition Resistor
R118		14	12-5562	5.6k ohm, $\pm 5\%$ , $\frac{1}{4}$ W Carbon Composition Resistor
RP1-RP4		15	19-012	470k ohm Resistor Network — CTS#750-101-R470K
	A4	26	37-14028	BCD-To-Decimal Decoder-Type MC14028
	B3	28	37-14556	Bual Binary to 1-of-4 Decoder/Demultiplexer — Type MC14556
	C1,C2 C4,C5	27	37-14511	8-Channel Data Selector — Type MC14511

Match/Credit PCB  
A030912-01

NOTICE TO ALL PERSONS RECEIVING THIS DRAWING  
 CONFIDENTIAL: Reproduction forbidden without the  
 specific written permission of Atari, Inc., Sunnyvale,  
 California. This drawing is only conditionally issued, and  
 neither receipt nor possession thereof confers or transfers  
 any right in, or license to use, the subject matter of the  
 drawing or any design or technical information shown  
 thereon nor any right to reproduce this drawing or any part  
 thereof, except for manufacture by vendors of Atari Incor-  
 porated and for manufacture under the corporation's writ-  
 ten license, no right to reproduce this drawing is granted or  
 the subject matter thereof unless by written agreement  
 with or written permission from the corporation.

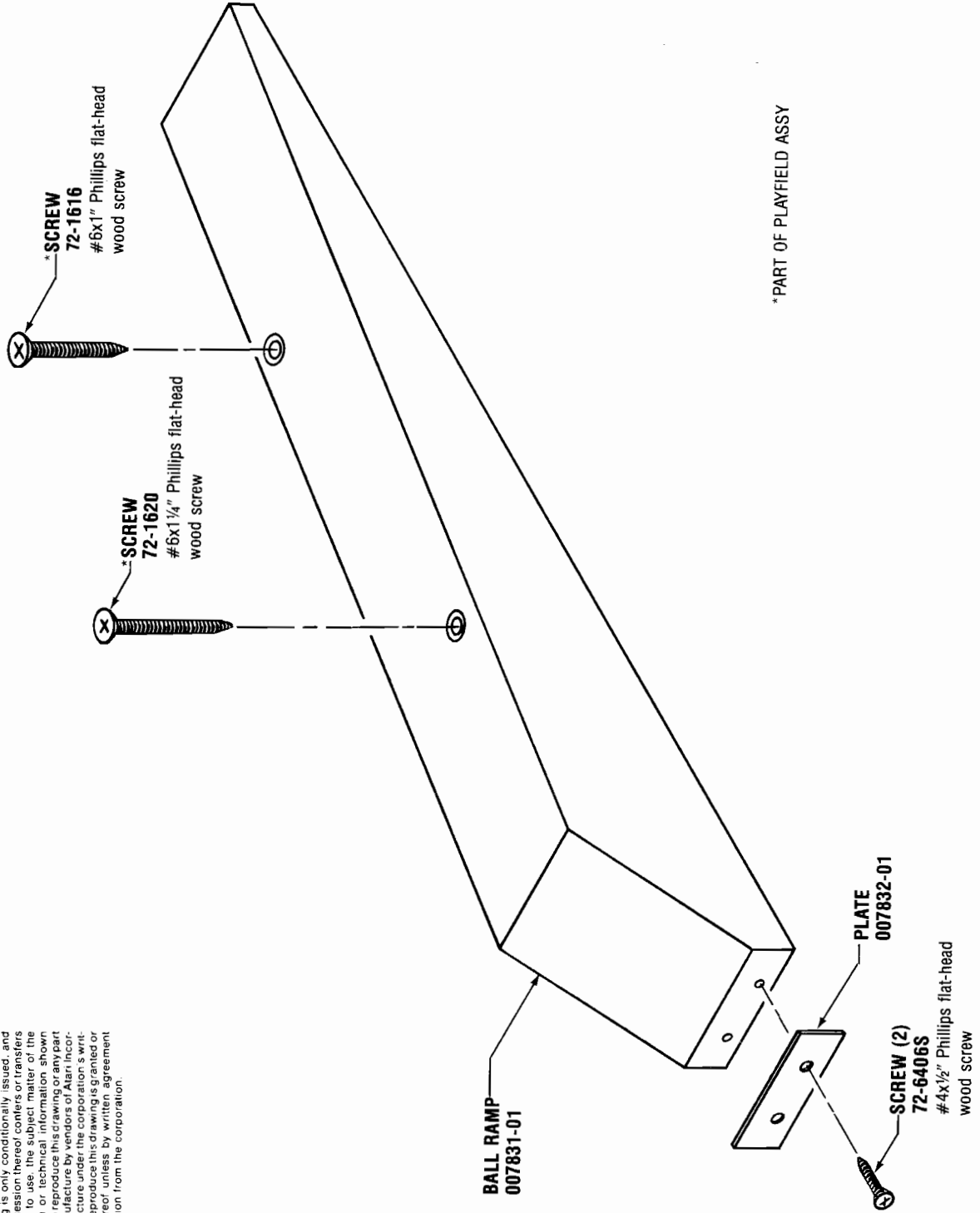

Ball Return Ramp  
 A007833-01



PLAYFIELD SUB-ASSEMBLY





First Fold

First Class  
Permit #1004  
Sunnyvale, CA

**BUSINESS REPLY MAIL**

*No postage stamp necessary if mailed in the U.S.A.*

**Atari, Inc.  
P.O. Box 9027  
Sunnyvale, California 94086**

**Attn.: Publications Group, Coin-Op Engineering**

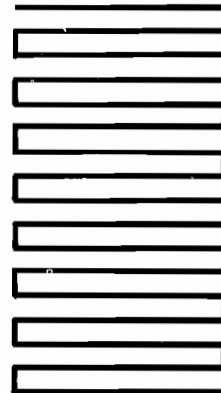

Cut along this line

Second Fold

Atari, Inc.  
P.O. Box 9027  
Sunnyvale, CA 94086

Tape This Edge

## WARRANTY

Seller warrants that its printed circuit boards and parts thereon are free from defects in material and workmanship under normal use and service for a period of ninety (90) days from date of shipment. Seller warrants that its television monitors (in games supplied with monitors) are free from defects in material and workmanship under normal use and service for a period of thirty (30) days from date of shipment. None of the Seller's other products or parts thereof are warranted.

If the products described in this manual fail to conform to this warranty, Seller's sole liability shall be, at its option, to repair, replace, or credit Buyer's account for such products which are returned to Seller during said warranty period, provided:

(a) Seller is promptly notified in writing upon discovery by Buyer that said products are defective;

(b) Such products are returned prepaid to Seller's plant; and

(c) Seller's examination of said products discloses to Seller's satisfaction that such alleged defects existed and were not caused by accident, misuse, neglect, alteration, improper repair, installation or improper testing.

In no event shall Seller be liable for loss of profits, loss of use, incidental or consequential damages.

EXCEPT FOR ANY EXPRESS WARRANTY SET FORTH IN A WRITTEN CONTRACT BETWEEN SELLER AND BUYER WHICH CONTRACT SUPERSEDES THE TERMS OF THIS ORDER, THIS WARRANTY IS EXPRESSED IN LIEU OF ALL OTHER WARRANTIES EXPRESSED OR IMPLIED, INCLUDING THE IMPLIED WARRANTIES OF MERCHANTABILITY AND FITNESS FOR A PARTICULAR PURPOSE, AND OF ALL OTHER OBLIGATIONS OR LIABILITIES ON THE SELLER'S PART, AND IT NEITHER ASSUMES NOR AUTHORIZES ANY OTHER PERSON TO ASSUME FOR THE SELLER ANY OTHER LIABILITIES IN CONNECTION WITH THE SALE OF PRODUCTS UNDER THIS ORDER.

This document is and contains confidential trade secret information of Atari, Inc.

This document is loaned under confidential custody for the sole purpose of operation, maintenance or repair of Atari equipment and may not be used by or disclosed to any person for any other purpose whatever, and remains the property of Atari, Inc.

Neither it nor the information it contains may be reproduced, used, or disclosed to persons not having a need to know consistent with the purpose of the loan, without written consent of Atari, Inc.



 A Warner Communications Company