



SERVICE BULLETIN

No. 1118-E
 Name of Product EIGHT BALL
 Effective All Games

October 1, 1977

THE FOLLOWING IS A LIST OF CORRECTIONS TO BE MADE ON ALL EIGHT BALL SCHEMATICS:

Schematic W-1182-3c

- A. Next to R68, ADD R69
- B. On J3, change J3-3 to S.P.S.A: J3-13 to CREDIT IND.
- C. Change

R8 to R16	R1 to R6	R5 to R3
R9 to R17	R2 to R5	R6 to R2
R10 to R18	R3 to R4	R35 to R36
R11 to R8	R7 to R1	R34 to R35
R4 to R7	R16 to R20	R22 to R31
R26 to R23	R21 to R9	R31 to R26
R25 to R22	R15 to R19	R36 to R45
R24 to R33	R18 to R15	R38 to R41
R17 to R21	R19 to R11	R44 to R43
R23 to R32	R33 to R34	R49 to R52
R48 to R51	R41 to R48	R45 to R42
R37 to R38	R40 to R46	R50 to R55
R32 to R25	R39 to R24	R51 to R56
R20 to R10	R47 to R49	R54 to R58
R42 to R47	R43 to R44	R55 to R59
R60 to R54	R52 to R37	
R59 to R53	R53 to R39	
R58 to R50		
R56 to R60		
R46 to R40		

Schematic W-1186-3, Sheet 2 of 3, top middle: +43VDC bus line (effective game serial #1907):

- A. Change 30 to 60, A2J1-6 (Wire Color Code)
- B. Add fuse, +43VDC bus, between right flipper and outhole ball eject coils

J

Bally

SERVICE BULLETIN

No. 1118-E

Name of Product EIGHT BALL

Effective All Games

October 1, 1977

Page 2

C. Add fuse description, "1 Amp, S.B., E-133-44".
Substitutions other than BALLY part number
not recommended

D. Outhole side of fuse, wire color is 30

Schematic W-1186-3, Sheet 1 of 3, effective game serial #1907:

A. A2J1, Pin 6, change color 30 to 60

B.M. Powers
Field Service Manager

Page 2 of 2

BMP:gdk

K

Games affected: Freedom, Night Rider, Eight Ball, Evel Knievel

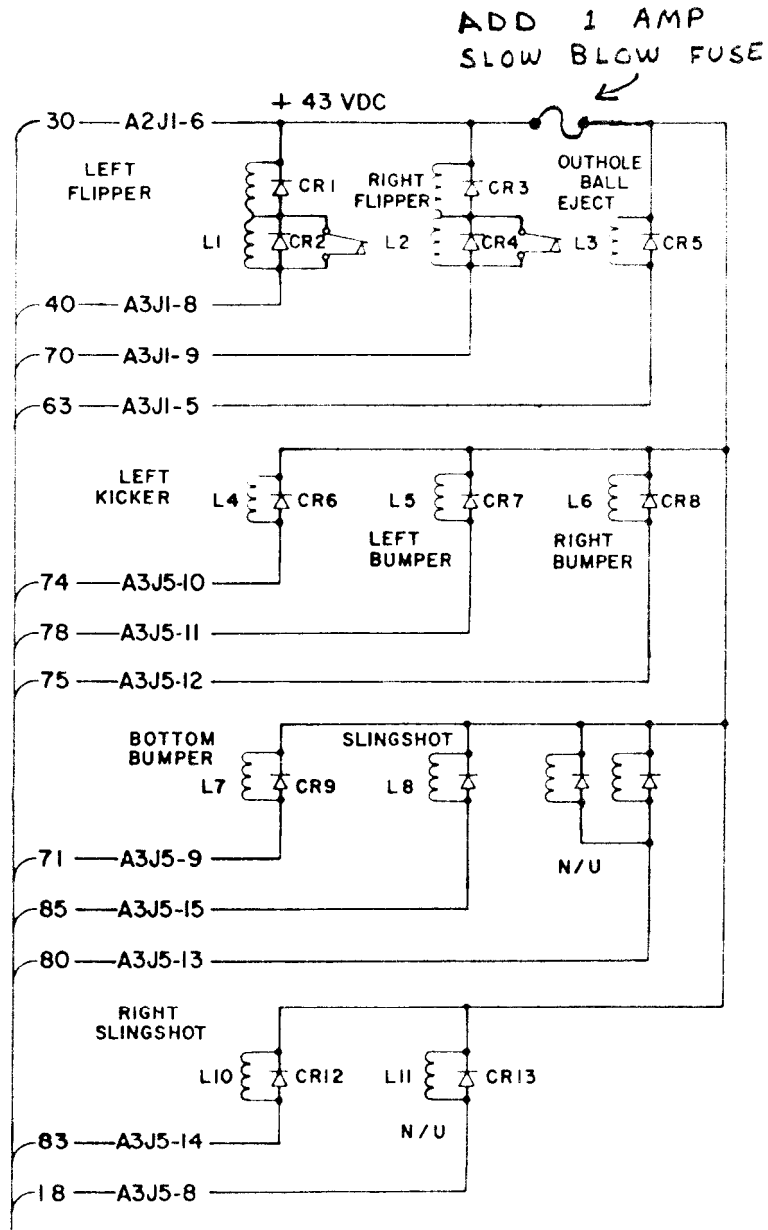

S