



OPERATIONS & PARTS INFORMATION MANUAL

GAME SHOW Jumper Chart

GAME	P/N-U15 Game uP	P/N-U27 G. ROM 1	P/N-U26 G. ROM 2	P/N-U21 S. ROM 1	P/N-U22 S.ROM 2	P/N-U24 Sound uP	JUMPERS
Transporter	5400-09150-00	A-5343-2008-2	A-5343-2008-1	A-5343-2008-4	A-5343-2008-3	5400-09150-00	W1, 2, 4, 5, 7, 8, 11, 14, 16, 17, 18
Elvira	5400-09150-00	A-5343-2011-2	A-5343-2011-1	A-5343-2011-4	A-5343-2011-3	5400-09150-00	W1, 2, 4, 5, 7, 8, 11, 14, 16, 17, 18
Mousin' Around	5400-09150-00	A-5343-2009-2	A-5343-2009-1	A-5343-2009-4	A-5343-2009-3	5400-09150-00	W1, 2, 4, 5, 7, 8, 11, 14, 16, 17, 18
Game Show	5400-09150-00	A-5343-2003-2	A-5343-2003-1	Not Used	Not Used	Not Used	W1, 2, 4, 5, 7, 11, 14, 16,

GAME SHOW Solenoid Table

Sol. No.	Function	Solenoid Type	Wire 1 Color	Connections		Driver Trnstr	Solenoid Part Number Flashlamp Type	
				CPU Bd	Playfield/ Cabinet		d= Display Bd; p=Playfield	
01A 3	Outhole Kicker	Switched	Vio-Brn }	1P11-1	5J1-9: 5J4-9 (A)	Q33	AE-23-800	
01B 3	Top Cntr Lv/Insert Teeth Flasher	Switched	Blk-Brn }	(Gry-Brn)	5J5-9 (C)	Q33	#89 Flashlamps	1b/1p
02A 3	Ball Shooter Ln Feeder	Switched	Vio-Red }	1P11-3	5J1-7: 5J4-8 (A)	Q25	AE-23-800	
02B 3	Rt Back Pnl/Insert 3 Mil Flasher	Switched	Blk-Red }	(Gry-Red)	5J5-8 (C)	Q25	#89 Flashlamps	1b/1p
03A 3	Not Used	Switched	Vio-Orn }	1P11-4	5J1-6: 5J4-7 (A)	Q32	Not Used	
03C 3	Left Plyfld/Insert Title Flasher	Switched	Blk-Orn }	(Gry-Orn)	5J5-7(C)	Q32	#89 Flashlamps	1b/1p
04A 3	Not Used	Switched	Vio-Yel }	1P11-5	5J1-5: 5J4-6 (A)	Q24	Not Used	
04C 3	Rt Plyfld/Insert Title Flasher	Switched	Blk-Yel }	(Gry-Yel)	5J5-5 (C)	Q24	#89 Flashlamps	1b/1p
05A 3	Ball Locker	Switched	Vio-Grn }	1P11-6	5J1-4: 5J4-5 (A)	Q31	AE-23-800	
05C 3	Upper Left Flasher	Switched	Blk-Grn }	(Gry-Grn)	5J5-4 (C)	Q31	#89 Flashlamp	1p
06A 3	Not Used	Switched	Vio-Blu }	1P11-7	5J1-3: 5J4-4 (A)	Q23	Not Used	
06C 3	Rt Back Pnl/Insert Wheel Flasher	Switched	Blk-Blu }	(Gry-Blu)	5J5-3 (C)	Q23	#89 Flashlamps	1b/1p
07A 3	Knocker	Switched	Vio-Blk }	1P11-8	5J1-2: 5J4-2 (A)	Q30	AE-23-800	
07C 3	Applause Flasher	Switched	Blk-Vio }	(Gry-Vio)	5J5-2 (C)	Q30	#906 Flashlamps	2b
08A 3	Car Drop Target	Switched	Vio-Gry }	1P11-9	5J1-1: 5J4-1 (A)	Q22	AE-23-800	
08C 3	Applause Flasher	Switched	Blk-Gry }	(Gry-Blk)	5J5-1 (C)	Q22	#906 Flashlamps	2b
9	Plyfld G.I. Relay	Controlled	Brn-Blk	1P12-1	5J2-9: 5J6-9: 2J4-3	Q17	5580-09555-01	4a
10	Top Ramp Gate	Controlled	Brn-Red	1P12-2	5J2-8: 5J6-8: 2J4-5	Q9	SM2-35-4000	
11	Center Ramp Flasher	Controlled	Brn-Orn	1P12-4	5J2-6: 5J6-7:	Q16	#89 Flashlamp	1p
12	A/C Select Relay	Controlled	Brn-Yel	1P12-5	2J4-6	Q8	5580-09555-01	5
13	Bell	Controlled	Brn-Grn	1P12-6	5J2-5	Q15	SM-26-600	
14	Ball Popper	Controlled	Brn-Blu	1P12-7	5J2-4: 5J6-5	Q7	AE-23-800	
15	Backbox G.I. Relay	Controlled	Brn-Vio	1P12-8	5J2-4: 5J6-3	Q14	5580-09555-01	4a
16	Insert Teeth/Title Flasher	Controlled	Brn-Gry	1P12-9	5J2-2: 5J6-2 5J2-1: 5J6-1 5J3-7: 5J7-7	Q6	#89 Flashlamps	4b
17	Left Jet Bumper	Special #1	Blu-Brn	1P19-7	5J3-6: 5J7-6	Q75	AE-23-800	
18	Left Kicker	Special #2	Blu-Red	1P19-4	5J3-3: 5J7-3	Q71	AE-26-1500	
19	Right Jet Bumper	Special #3	Blu-Orn	1P19-3	5J3-4: 5J7-5	Q73	AE-23-800	
20	Right Kicker	Special #4	Blu-Yel	1P19-6	5J3-2: 5J7-2	Q69	AE-23-1500	
21	Bottom Jet Bumper	Special #5	Blu-Grn	1P19-8	5J3-1: 5J7-1	Q77	AE-23-800	
22	Not Used	Special #6	Blu-Blk	1P19-9		Q79	Not Used	
-	Right Flipper Lower Right Flipper	-	Orn-Vio 2 [Blu-Vio]	1P19-1	2J5-5: 2J10-7 [2J10-1: 2J8-15]	-	FL11630/ 50VDC	
-	Left Flipper Lower Left Flipper	-	Orn-Gry 2 [Blu-Gry]	1P19-2	2J5-4: 2J10-8 [2J10-2: 2J8-4]	-	FL11630/ 50VDC	

Notes 1. Wire colors, except flipper Orn- Vio and Orn-Gry are ground connections (to terminal with unbanded end of diode). Flipper Orn-Vio and Orn-Gry wires connect from CPU Board to flipper switch. 2. Flipper connections shown in braces are from flipper switch to flipper coil. 3. "A" circuits are pulsed, when Sol. 12 is de-energized; "C" circuits are pulsed, with Sol. 12 energized. Wire colors in brackets are those from respective A and C terminals corresponding to the J1-terminal connection listed for the Aux Power Driver Bd. which controls the device pulsing by Sol. 12. 4. Relay is mounted on Relay bd. (4a) C-11998-1; (4b) C-11902-1. 5. Relay mounted on Aux. Power Driver Bd., D-12247.

GAME SHOW

GAME SHOW RULES

GETTING A BALL THROUGH THE TOP CENTER LANE AWARDS BONUS MULTIPLIER WHEN FLASHING AND COMPLETES THE SHOOTER SKILL SHOT.

LIGHTING THREE TOP LANES ADVANCES BONUS MULTIPLIER.

SPIN WHEEL AWARDS THE LIT SCORE VALUE OF 5,000 TO 50,000 POINTS AND POSSIBLY LIGHTS THE EXTRA BALL, AWARDS 250,000 POINTS, AWARDS HOLD BONUS, AWARDS 1 MILLION POINTS OR, LIGHTS THE 4 MILLION.

SPIN WHEEL LIT OPERATES THE WHEEL AT HIGH SPEED UNTIL THE LEFT RETURN LANE IS HIT, NUDGE THEN FLASHES. OPERATING THE WHEEL WITH NUDGE FLASHING ROTATES THE WHEEL ONE POSITION CLOCKWISE.

THE RIGHT RETURN LANE LIGHTS 5X AND 3K SPINNER.

THE LEFT RETURN LANE LIGHTS THE 3K SPINNER.

SPOT LETTER LIT TO LIGHT T-V-T-R-I-P-T-R-U-C-K-CAR.

BIG BUCKS AWARDS 100K THRU 1 MILLION AND IS STORED IN MEMORY.

LIGHTING THE CAR, TRUCK, TRIP AND TV, LIGHTS LOCKS,

THE GRAND PRIZE OF 3 MILLION FLASHES AT THE BEGINNING OF MULTI-BALL™ FOR 4 SECONDS THEN COUNTS DOWN TO 1 MILLION. IF THE PLAYER LOSES 1 BALL THE GRAND PRIZE TIMES OUT IN 5 SECONDS.

SPOT 3 LETTERS WITHIN 18 SECONDS TO LIGHT 4 MILLION ON THE WHEEL.

COLLECTING ANY PRIZE LIGHTS THE FOLLOWING WHEEL LIGHTS
EXTRA BALL LIGHT
\$250,000 LIGHT

THE OUTLANE EXTRA BALL LIGHT IS LIT BY GAME ADJUSTMENT 44. AT THE OPERATORS DISCRETION IT CAN BE SET AT
EASY=3X
MEDIUM=4X
HARD=8X

TABLE OF CONTENTS

SECTION 1

Game Operation & Test Information

GAME SHOW ROM Summary.....	1-1
Connector Identification.....	1-2
Circuit Boards.....	1-2
Fig. 1 Locations Diagram - Game Circuit Boards and Major Mechanisms..	1-3
Game Control Locations, Fig. 2.....	1-4
Pinball Game Assembly Instructions Fig. 3.....	1-5
Game Operation.....	1-7
Game Status Displays.....	1-9
Audit Table.....	1-11
Game Adjustment Table.....	1-12
Game Adjustment Comparison Table.....	1-13
Game Adjustment Procedure.....	1-14
Preset Game Adjustments Table for German/European Games.....	1-26
Preset Game Adjustments Table for U.S./Canadian Games.....	1-27
Resetting the High Scores.....	1-30
Game Pricing	1-31
Pricing Table.....	1-31
Test/Diagnostic Information.....	1-34
Music Test.....	1-34
Display Test.....	1-35
Lamp Tests.....	1-35
Lamp Matrix Table.....	1-36
Solenoid Test.....	1-36
Solenoid Table.....	1-37
Special & Controlled Solenoids - Diagrams & Details.....	1-38
Typical Solenoid A/C Select Relay Circuit, Fig. 4.....	1-38
Switch Tests.....	1-39
Switch Matrix Table.....	1-39
C-Side Test.....	1-41
Ending the Diagnostic Tests.....	1-41
Auto Burn-In Mode.....	1-41
System 11-B Memory Chip Test.....	1-42
CPU LED Indicator Table.....	1-42
System 11-B Sound Circuitry Tests.....	1-43
Problem Analysis Messages.....	1-44
Maintenance Information, Fig. 5.....	1-45
Fuse Locations Diagram & Listings.....	1-47

SECTION 2

Game Parts Information

Cabinet Parts.....	2-2
Major Mechs. & Circuit Boards.....	2-3
System 11B CPU Board Parts Layout & Listing.....	2-4
Right Display Board Parts Layout & Listing.....	2-6
Left Display Board Parts Layout & Listing.....	2-7
Power Supply Board Parts Layout & Listing.....	2-8
Audio Board Parts Layout & Listing.....	2-9
Aux Power Driver Board Parts Layout & Listing.....	2-10
Backbox Interconnect Board Parts Layout & Listing.....	2-11
Sound Overlay Lamp Assembly Parts Layout & Listing.....	2-12
Flipper Assemblies.....	2-13
Kicker (Slingshot) Assemblies.....	2-14
Ball Trough Switches & Stand-up Target.....	2-15
Outhole Kicker & Ball Shooter Lane Feeder.....	2-16
Jet Bumper & Kicker Assemblies.....	2-17
Top Ramp Gate, Multi-ball Kicker (Ball Locker), Ball Shooter.....	2-18
Ball Popper & Extension Assembly.....	2-19
Bell & Drop Target Assemblies.....	2-20
Playfield Posts & Relay Board.....	2-21
Coin Door Assembly.....	2-22
Lamp Matrix Table & Location.....	2-24
Switch Matrix Table & Location.....	2-26
Solenoid Table & Location.....	2-28
Playfield Parts List & Location.....	2-30
Lamp Board Assemblies.....	2-32
Ramp Assemblies.....	2-33
Backbox, Cables & Miscellaneous Parts Lists.....	2-34
Unique Parts List.....	2-35
Display Glass Pinout Table.....	2-36

SECTION 3

Reference Diagram & Schematics

Cabinet Wiring Diagram.....	3-2
Power Supply & Sound Overlay Lamp Assembly Layout.....	3-3
Sound Overlay Lamp Assembly Schematic.....	3-4
Power Supply Schematic.....	3-5
System 11B CPU Layout.....	3-6
System 11B CPU Schematic.....	3-7
Bally Right Display Board Layout	3-11
Bally Right Display Board Schematic.....	3-12
Bally Left Display Board Layout.....	3-13
Bally Left Display Board Schematic.....	3-14
Backbox Interconnect, Audio & Aux Power Driver Boards Layout	3-15
Backbox Interconnect Board Schematic.....	3-16
Audio Board Schematic.....	3-17
Aux. Power Driver Board Schematic.....	3-18
Controlled, Switched, & Special Solenoids.....	3-19
Power Wiring Diagram.....	3-20
Interboards Signals.....	3-21
Diagnostic Test Flowchart.....	3-23

Game Operation
and
Test Information

GAME SHOW ROM SUMMARY

IC	DESCRIPTION	TYPE	IDENTIFIER	BOARD	PART NUMBER
Game ROM 1	32K x 8 ROM	27256	U27	CPU	A-5343-2003-2
Game ROM 2	32K x 8 ROM	27256	U26	CPU	A-5343-2003-1
Music/Speech ROM	64K x 8 ROM	27512	U4	AUDIO	A-5343-2003-5
Music/Speech ROM	64K x 8 ROM	27512	U19	AUDIO	A-5343-2003-6
Music/Speech ROM	64K x 8 ROM	27512	U20	AUDIO	A-5343-2003-7

Connector Identification

Since *GAME SHOW* is using WILLIAMS ELECTRONICS GAMES System 11B, a new connector identification technique must be introduced. Each plug or jack receives a prefix number (which identifies the circuit board), followed by a letter ("J" or "P"), and a number. J-designations refer to the male part of a connector. P-designations refer to the female part of a connector. For example, 1J1 designates jack 1 of board 3 (a CPU Board jack); 3P6 designates plug 6 of board 3 (a Power Supply Board plug). Identifying the specific pin number of a connector involves a hyphen, which separates the pin number from the plug or jack designation. For example, 1J1-3 refers to pin 3 of jack 1 on board 1.

Other game components may also have similar prefixes preceding their designator to clarify their locations or related circuit.

Prefix numbers for the System 11B circuit boards and other major assemblies are listed below. A prefix number may precede a component designator to identify its associated unit (e.g., connector1J1).

1 - CPU	6 - Backbox
2 - Master Interconnect	7 - Cabinet
3 - Backbox Power Supply	8 - Playfield
4 - Alphanumeric Display	9 - Insert Board
5 - Aux Power Driver	10 - Sound Board

Circuit Boards

System 11B Circuit Boards for *GAME SHOW* are in the backbox. They are accessible by unlocking the Backbox lock, removing the Backbox glass, unlatching the Insert Board (with lamps and the Digital Display Boards), and swinging it open.

Lamp circuit boards are mounted on the Playfield and the Insert Board.

CONTROL BOARD

The System 11B CPU Board (p/n D-11883-2003) must be equipped with the ROMs specified in the *GAME SHOW* ROM Summary. CPU Board jumpers W1, W2, W4, W5, W7, W8, W11, W14, W16, W17, and W19 must be connected.

SOUND BOARD

The Sound Board is p/n D-11581-2003, including ROMs and micro-processor.

DISPLAY BOARD

GAME SHOW has two Display Boards. The BALLY Right Display Board is p/n D-12502-1, and the BALLY Left Display Board is p/n D-12706.

1-2 Control Locations

POWER SUPPLY BOARD

The Power Supply Board is p/n D-12246.

AUX POWER DRIVER BOARD

The Aux Power Driver Board is D-12247-2003.

MASTER INTERCONNECT BOARD

The Master Interconnect Board is D-12313-2003.

CIRCUIT BOARD & MAJOR MECHANISMS LOCATION DIAGRAM

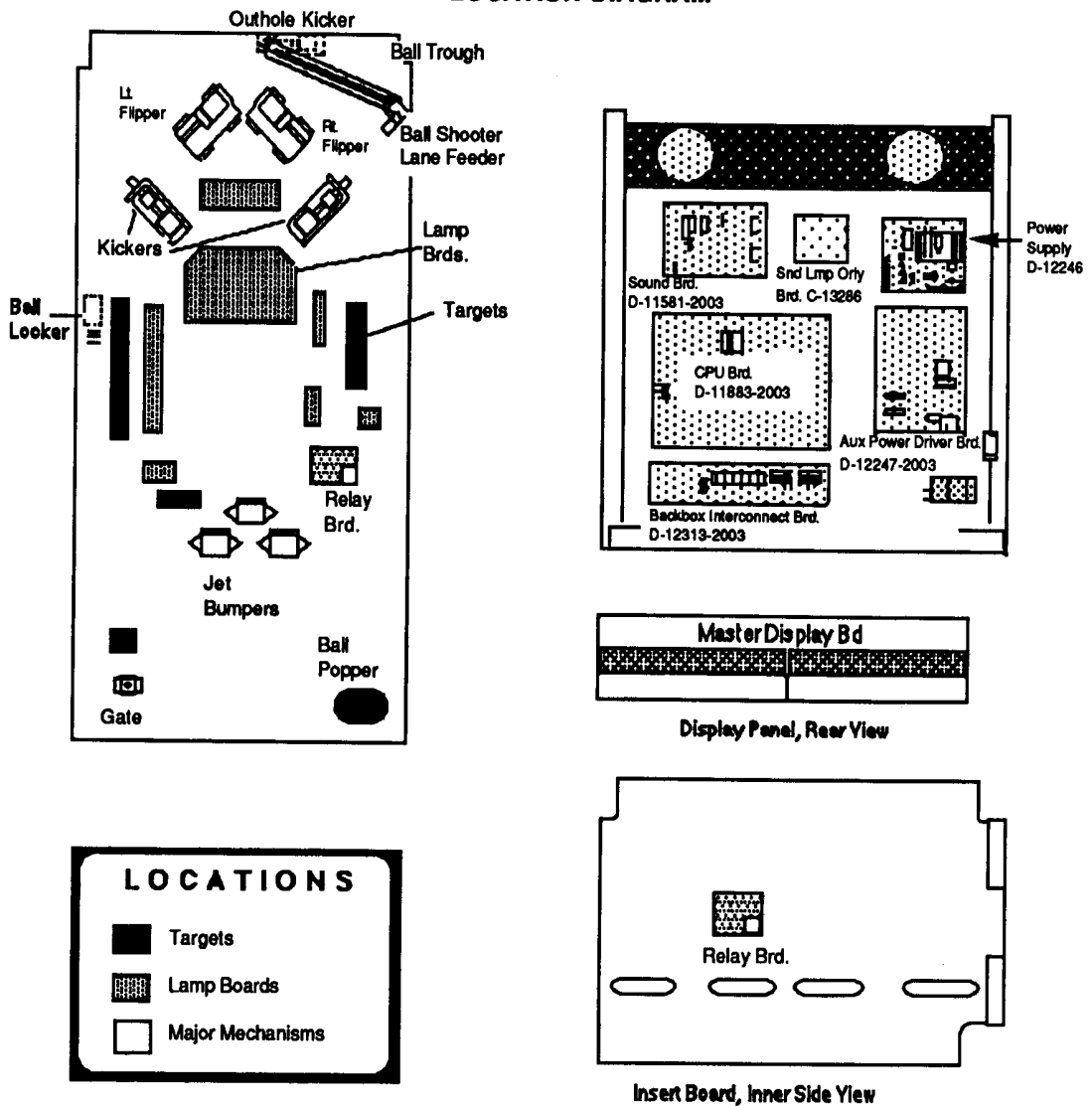

Figure 1. Locations Diagram - Game Circuit Boards and Major Mechanisms.

Game Control Locations

Figure 2 shows the locations of the following switches, except for the last two (CPU and Sound Diagnostic switches, which are shown in the Circuit Board Locations Diagram).

THE ON-OFF SWITCH is on the bottom of the cabinet near the right front leg.

THE VOLUME CONTROL is on the left inner wall of the cabinet on the tilt mechanism board. It is accessible by opening the coin box door.

THE CREDIT SWITCH is a pushbutton to the left of the coin door on the cabinet exterior.

GAME ADJUSTMENT/DIAGNOSTIC SWITCHES. *GAME SHOW* allows the operator to control all game adjustments, obtain bookkeeping information, and diagnose problems, using only three switches mounted on the inside of the coin door, along with the Credit button beside the coin door.

ADVANCE, AUTO-UP/MANUAL-DOWN, and HIGH-SCORE RESET are the switches located on the inside of the coin door. Refer to the text discussing Game Status Displays and the Test/Diagnostic Procedures for details concerning button operation.

THE MEMORY PROTECT SWITCH is on the inside frame of the coin door. This interlock switch must be open to clear bookkeeping totals and to make game adjustments. It automatically opens, when the coin door opens.

On the previous page, the Circuit Board Locations Diagram shows the location of the CPU Board switch (left edge of CPU Board, Backbox View).

THE CPU DIAGNOSTIC SWITCH (SW 2) is near a large, socketed microprocessor chip. This switch initiates the Memory Chip Test explained in the Test/Diagnostic Procedures.

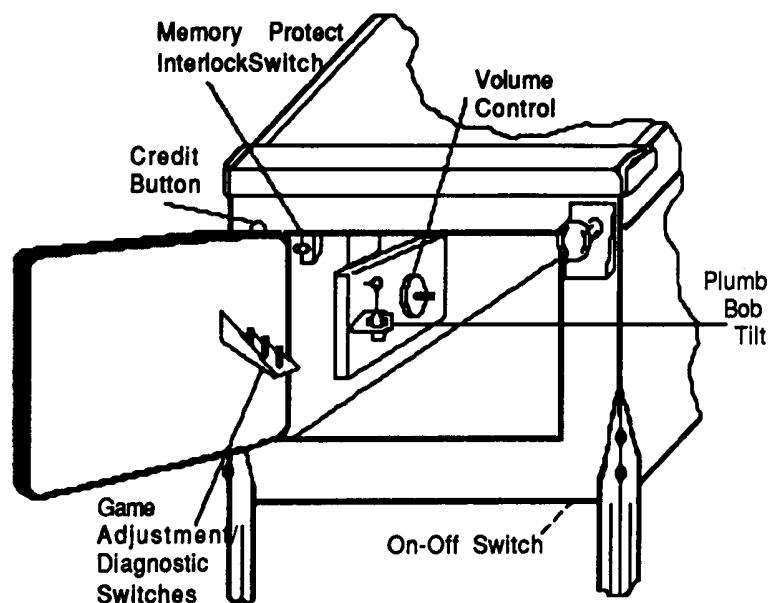

Figure 2. Control Locations

Pinball Game Assembly Instructions

INSTALLATION PROCEDURE

1. Open the shipping container; remove all cartons, parts, and other items, and set them aside.
2. Leg levelers and bolts are provided in the cashbox. Place cabinet on a support and attach rear legs (after installing leg levellers), using leg bolts.
3. Attach the front legs (after installing leg levellers), using leg bolts. See Figure 3 for details.

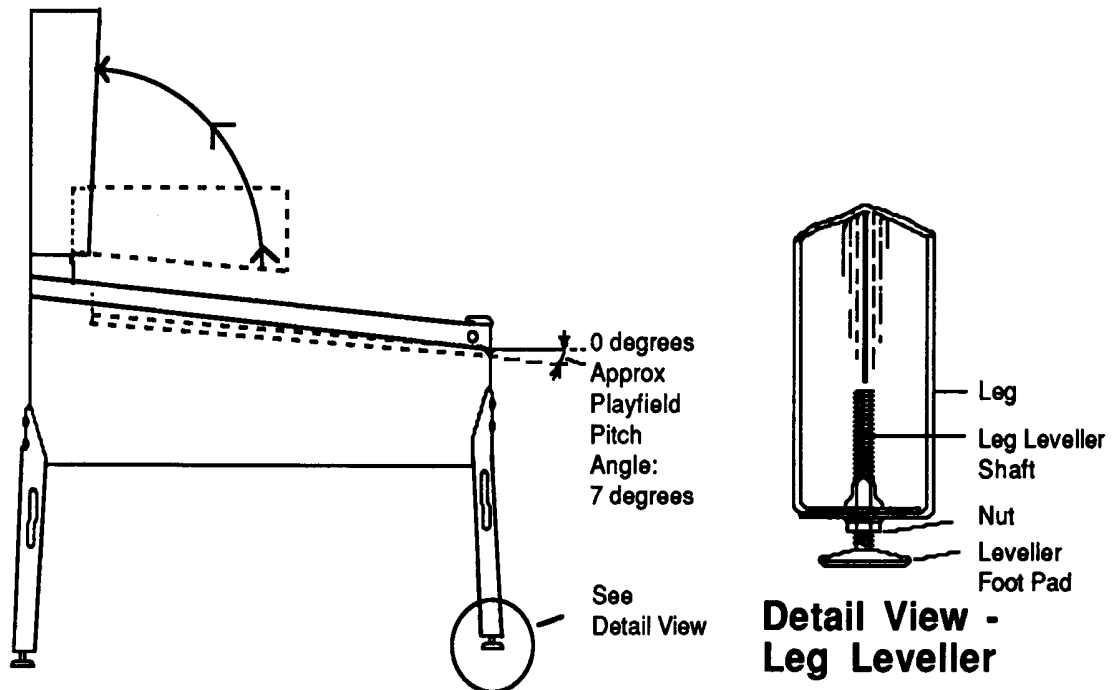

Figure 3. Pinball Assembly, Playfield Pitch Angle, and Leg Leveler Details.

CAUTION

Ensure that the interconnecting cables are free to move (not kinked or pinched). Be careful not to damage wires at any stage of the assembly process.

4. Raise the hinged backbox upright and stabilize it into position. Unlock the backbox, and remove the backbox glass, storing it carefully to avoid scratches. Remove the shipping block holding the Insert Board. This allows access to the bolt holes used for securing the backbox upright. Install the mounting bolts, split lockwashers, and flat washers through the bottom holes of the backbox into the threaded fasteners in the cabinet to secure the backbox. Close and latch the Insert Board, and install the backbox glass, and lock the backbox.

WARNING

NEVER transport a pinball game with hinged backbox erect. Always lower the backbox forward onto the playfield cabinet on a layer of protective material to prevent marring or damage and possible personal injury.

5. Extend each leg leveller slightly below the leg bottom, so that all four foot pads are extended about the same distance. Remove the cabinet from its support and place it on the floor.
6. Adjust the leg levers for proper playfield level (side-to-side) and playfield pitch angle (incline) of approximately 7 degrees. (Again, it is recommended that these measurements be made ON the playfield, not the cabinet nor the playfield cover glass.) Tighten the nut on each leg leveller shaft to maintain this setting, as shown in Figure 3.

CAUTION

Playing pitch angle adjustments can affect the operation of the plumb bob tilt, inside the cabinet. The plumb bob weight is among the parts in the cash box; the operator should install the weight and adjust the tilt mechanism for proper operation, after completion of the desired playfield pitch angle setting.

7. Move the game into the desired location: recheck the level and pitch angle of the playfield.
 8. Verify that the required number of balls are inside the game. *GAME SHOW* uses two (2) balls.
 9. Clean and re-install the playfield cover glass. Prepare the game for player operation.
-
-

Game Operation

WARNING

After assembly and installation at its site location, this game must be plugged into a properly grounded outlet to prevent shock hazard, and to assure proper game operation. DO NOT use a 'cheater' plug to defeat the ground pin on the line cord. DO NOT cut off the ground pin.

POWERING UP

With the coin door closed, plug the game in, and switch it ON, using the On-Off switch. In normal operation, the player 1 score display initially shows 00. Then, the game goes into the Attract Mode (playfield and backbox lamps flashing, sounds being heard, etc., if the operator does not change the Factory Setting).

Open the coin door and press the AUTO-UP/MANUAL-DOWN switch to MANUAL-DOWN. Press the ADVANCE button to begin the game test routine. Return to AUTO-UP and perform the entire test to verify that the game is operating satisfactorily.

NOTE

The SYSTEM 11B game program has a great capability to aid the operator and service personnel: At game Turn-On (and also at the beginning of the Test/Diagnostic Procedures), the player score displays now signal with a message, "Press ADVANCE for Report", that the game program has detected a possible problem with the game. Usually, this report indicates that at least one switch has NOT been actuated during ball play for 90 balls (apx. 30 games). However, the game program compensates the game play requirements affected by each disabled switch to allow 'nearly normal' play. This helps keep *GAME SHOW* earning good profits! More information is available in the Test/Diagnostic Procedures text describing the Switch Testing.

ATTRACT MODE*

Playfield and backbox lamps blink. The player score displays exhibit a series of messages informing the player concerning:

- A. Recent highest scores*;
- B. A "custom message";
("COME ON DOWWWN, WIN A NEW CAR AND BIG BUCKS.")*;
- C. The score to achieve to obtain a
Replay award*;

These (or similar) displays reappear occasionally, accompanied by sounds and music, until a player initiates game play by inserting a coin or, when credits are available, pressing the Credit button.

CREDIT POSTING

Insert coin(s). A sound is heard for each coin, and the player score displays show the number of credits purchased. So long as the number of maximum allowable credits* are NOT exceeded by coin purchase or high score, credits are posted correctly.

STARTING A GAME

Press the Credit button once. A startup sound plays, and the Credit amount shown in the player score display decreases by one. Player display 1 flashes 00 (until the first playfield switch is actuated), and the Player 4 display shows ball 1, except for 4-player games where the ball # shows in the individual player's display. Additional players may enter the game by pressing the Credit button once for each player, before the end of play on the first ball.

SLAM TILT

Actuating the Slam Tilt switch on the coin door inside the cabinet ends the current game; *GAME SHOW* then proceeds to the Game Over Mode. With the actuation of the playfield tilt switch, or the third closure* of the plumb bob tilt switch, the player loses the remaining play of that ball, but can complete the game.

END OF GAME

All earned scores and bonuses are awarded. If a player's final score exceeds the specified value, the player receives a designated award for achieving the current highest score. A random digit set* appears in the Match display. Credit* may be awarded, when the last two digits of any player's score display (1 through 4) match the random digits of the Match display. Match, high score, and game over sounds are made, as appropriate.

GAME OVER MODE

The *GAME OVER* display shows in the player score displays. Then, the high scores flash on the appropriate player score displays. The game proceeds to the Attract Mode.

* - operator-adjustable feature

Game Status Displays

INTRODUCTION

GAME SHOW provides the game owner/operator with a display of information concerning the game's bookkeeping and game play feature adjustments. Basically, three classes of information now become available in this status display mode:

- Id (Identification);
- Au (Audit);
- Ad (Adjustment).

Each of the two-letter abbreviations for these classes appears in the score display, while the system microprocessor for the *GAME SHOW* game is displaying the items within each class.

IDENTIFICATION INFORMATION--Id

With the game turned on, the coin door open, and the AUTO-UP/MANUAL-DOWN switch in the AUTO-UP position, the operator can press the ADVANCE switch once, briefly. Player displays immediately change from the Attract Mode to the Game Status Display Mode. This is evident by the following display, shown in columnar form. The column headings refer to the various backbox displays.

Player 1	Player 2	Player 3	Player 4
GAME	SHOW	2003 LA-x*	ID00

* x - indicates ROM revision level; e.g., 1 is initial issue; 2, 3, etc. for later revisions; A indicates American.

The game is named in the Player 1 and 2 score display. The ROM revision level appears in the Player 3 score display. The Player 4 score display shows the status display mode in abbreviated form, Id. The Player 4 score display also shows the status display mode item (00) for this particular display. Pressing advance (to Id 01) once more shows the Game Revision information.

Player 1	Player 2	Player 3	Player 4
DOMESTIC	LEVEL 1	12-12-89	ID01

The country is named in the Player 1 score display. The Production Level appears in the Player 2 score display. The game's release date appears in the Player 3 score display and the status display mode information is shown in the Player 4 display.

Pressing ADVANCE once more causes the Id 02 display to appear. This display describes which of the "Install" options is currently in effect. For example, if the YES option of the INSTALL FACTORY Adjustment Item (Ad 70) was last selected, FACTORY SETTING appears on the player score displays. Changing the setting of any other game adjustment item, after selecting the YES option for Ad 70 causes the display to change to FACTORY ALTERED. Similarly, if the operator selects the YES option for INSTALL HARD (Ad 65), the display indicates HARD SETTING. Changing a game adjustment item later then causes the display to show HARD ALTERED.

AUDIT INFORMATION - Au

While the AUTO-UP switch remains in the Up position, the operator can press the ADVANCE switch once, briefly, to begin the backbox displays of Audit (sometimes called "bookkeeping") Information. Fifty-four audit entries are now available. Calculation of the various factors is no longer necessary because the System 11B game program now performs all the mathematical factor computations. This information is intended to aid the owner/operator in evaluating how the game is performing in each location, by providing knowledge about which game features are receiving the most play. With this information, the owner/operator can determine whether adjusting the game features to other settings will contribute to increased game earnings.

The operator can press the ADVANCE button once to view each Audit Information display item. To proceed more rapidly through this information, the operator only has to press and hold the ADVANCE button. If a desired item is passed, the operator can use the MANUAL-DOWN switch position with the ADVANCE button to back up to the desired item.

The *GAME SHOW* Audit Table lists the 53 items of the Audit Information portion of the *GAME SHOW* Game Status Displays, audit 54 is not used. Presentation of this Audit Information again utilizes the player score displays; however, the Player 1 and 2 displays are combined as a descriptive phrase. The light type below the table's column headings names the respective backbox displays where the information appears. Because the Player 4 display contains information which depends on game play, only a few example entries are shown in the table. The Credits display shows Au for all 53 audit items, so its entry is omitted from the tabular listing. Detection of erroneous data affecting any of the counters used in these audit items causes the message, ERROR, to be displayed in the Player 3 display, during display of any audit item associated with that particular counter. (The program does not analyze the cause of the error; it merely alerts the operator of the error's existence by the message.)

ADJUSTMENT INFORMATION - Ad

At end of the Audit Information presentation, with the AUTO-UP switch in the Up position, the operator can press the ADVANCE button to proceed to the Adjustment Information portion of the *GAME SHOW* Game Status Displays, as listed in the *GAME SHOW* Game Adjustment Table.

The operator can press the ADVANCE button once to view each Adjustment Information display item. To proceed more rapidly through this information, the operator only has to press and hold the ADVANCE button. If a desired item is passed, the operator can use the MANUAL-DOWN switch position with the ADVANCE button to back up to the desired item.

The *GAME SHOW* Game Adjustment Table lists the 70 items of the Adjustment Information portion of the *GAME SHOW* Game Status Displays. Presentation of the displays is similar to that for the Audit Information (that is, the player 1 and 2 displays combine as a descriptive phrase; the light type below the column headings

GAME SHOW AUDIT TABLE

Audit Item (Right)	Descriptive Phrases (Left Display)	Audit Factor 1 Value (Right)
AU 01	LEFT COINS [chute next to coin door hinge]	432
02	CENTER COINS	0
03	RIGHT COINS	398
04	PAID CREDITS	830
05	TOTAL PLAYS	
06	TOTAL FREE (Total Free Plays)	
07	PERCENT FREE (% Free Plays)	
08	REPLAY AWARDS	
09	PERCENT REPLAY (% Replay Awards)	
10	SPECIAL AWARDS	
11	PERCENT SPECIAL (% Special Awards)	
12	MATCH AWARDS	
13	HSTD (High Score to Date) CREDITS	
14	PERCENT HSTD (% HSTD Credits)	
15	EXTRA BALLS	
16	PERCENT EX. BALL (% Extra Balls)	
17	AV. BALL TIME (Average Time in Seconds)	
18	MINUTES OF PLAY (Minutes of Play)	
19	BALLS PLAYED	
20	REPLAY1 AWARDS	
21	REPLAY2 AWARDS	
22	REPLAY3 AWARDS	
23	REPLAY4 AWARDS	
24	1 PLAYER GAMES	
25	2 PLAYER GAMES	
26	3 PLAYER GAMES	
27	4 PLAYER GAMES	
28	BURN-IN CYCLES	
29	MADE SPOT LETTER (Total # of times Spot Letter made)	
30	MADE MULTI-BALL™ (Total # of times Multi-ball made)	
31	MADE GRAND PRIZE (Total # of times Grand Prize made)	
32	MADE BONUS 8X (Total # of times Bonus 8X made)	
33	MADE OUTLANE EXTRA BALL (Total # of times E.B. via Outlanes made)	
34	WHEEL EXTRA BALL LIT (Total # of times Wheel Extra Ball was lit)	
35	WHEEL 1 MILLION (Total # of times 1 Million made via Wheel)	
36	WHEEL 2 MILLION (Total # of times 2 Million made via Turn Lane)	
37	WHEEL BONUS HOLD (Total # of times Bonus Hold made via Wheel)	
38	MADE BIG BUCKS (total # of times Big Bucks made)	
39	H.S.RESET COUNTER	
40	0.0-0.4 MIL. SCORE (# of games <500K)	
41	0.5-0.9 MIL. SCORE (# of games ≥500K, <1M)	
42	1.0-1.4 MIL. SCORE (# of games ≥1M, <1.5M)	
43	1.5-1.9 MIL. SCORE (# of games ≥1.5M, <2.0M)	
44	2.0-2.9 MIL. SCORE (# of games ≥2.0M, <2.9M)	
45	3.0-3.9 MIL. SCORE (# of games ≥3.0M, <3.9M)	
46	4.0-4.9 MIL. SCORE (# of games ≥4.0M, <4.9M)	
47	5.0-5.9 MIL. SCORE (# of games ≥5.0M, <5.9M)	
48	6.0-7.9 MIL SCORE (# of games ≥6.0M, <7.9M)	
49	8.0-9.9 MIL SCORE (# of games ≥8.0M, <9.9M)	
50	10-99 MIL. SCORE (# of games ≥10.0M, <99 M)	
51	AV. MIN. GAME TIME (Avg Game Time in minutes)	
52	LEFT OUTLANE (Total # of times ball hit Left Outlane)	
53	RIGHT OUTLANE (Total # of times ball hit Right Outlane)	

NOTE:
 1. The numbers shown in this column for Items 1 through 4 are examples.
 Entries for all items depend on the amount of play; thus, they will vary from location to location.

GAME SHOW Game Adjustment Table

Adjustment Item (Player 3)	Descriptive Phrases (Player 1 and 2 Displays)	Factory Setting	
		Domestic (US/Can.)	W.Ger./ European
Ad 01	AUTO REPLAY ¹ or FIXED REPLAY ¹	10 (%) SCORES ¹	ON
02	REPLAY START (or REPLAY LEVEL 1)	4,500,000	
03	REPLAY LEVELS (or REPLAY LEVEL 2) ¹	02	02
04	(REPLAY LEVEL 3) ¹	(see text)	
05	(REPLAY LEVEL 4) ¹	(see text)	
06	REPLAY AWARD	Credit	
07	SPECIAL AWARD	Credit	
08	MATCH FEATURE	7 (%)	
09	BALLS/GAMES	03	
10	TILT WARNING	03	
11	MAXIMUM EXTRA BALL	02	
12	MAXIMUM CREDITS	10	30
13	HIGHEST SCORES	On	
14	BACKUP HI. SCR. 1	8,000,000	8,500,000
15	BACKUP HI. SCR. 2	7,500,000	8,000,000
16	BACKUP HI. SCR. 3	7,000,000	7,500,000
17	BACKUP HI. SCR. 4	6,500,000	7,000,000
18	HI. SCR.1 CREDITS	01	03
19	HI. SCR.2 CREDITS	01	00
20	HI. SCR.3 CREDITS	01	00
21	HI. SCR.4 CREDITS	01	00
22	H. S. RESET EVERY	3,000	1,000
23	FREE PLAY	NO	
24	U.S.A. 1 COINAGE (1 COIN 1 PLAY) ^{2,3,6}	USA 2	GERMAN 2
25	LEFT UNITS	01	06
26	CENTER UNITS	04	12
27	RIGHT UNITS	01	30
28	UNITS/ CREDIT	01	05
29	UNITS/ BONUS	00	00
30	MINIMUM UNITS	00	00
31 - 48	Game-specific Adjustments (detailed in text and the Game Adjustment Setting Comparison Table)		
49 ⁴	CUSTOM MESSAGE	ON	
50	DISPLAY AU (01 - 04)	YES	
51 - 52	NOT USED		
53 - 58 ^{5,6}	Special Adjustments- See text for 53-58 details.		
59 ⁵	INSTALL ADDABALL	NO	
60 ⁵	INSTALL 5-BALL	NO	
61 ⁵	INSTALL NOVELTY	NO	
62 ⁵	INSTALL EX. EASY	NO	
63 ⁵	INSTALL EASY	NO	
64 ⁵	INSTALL MEDIUM	NO	
65 ⁵	INSTALL HARD	NO	
66 ⁵	INSTALL EX. HARD	NO	
67	AUTO BURN-IN	NO	
68	CLEAR COINS	NO	
69	CLEAR AUDITS	NO	
70 ⁷	INSTALL FACTORY	NO	

NOTES:

- 1 Automatic Replay percentage value range is adjustable from 5 to 50%, via the Credit Button. Item 02 permits changing the factory setting value for Replay Start Level valid for the next 500 games played. Item 03 permits setting up four replay levels, values as detailed in text describing Item 03. For Fixed Replay Scores set Auto Replay value to 1 less than 5% via the credit Button. Go to items 02, 03, 04, and 05; install their replay level scores. Turn off any replay level by setting 00 as its value.
- 2 Phrase in parentheses is Factory Setting. Phrase appears in player 2 and 4 displays. Press Credit button to change setting of the game pricing of item 24.
- 3 To change country OR coinage setting, press Credit button to obtain 24 Standard settings, followed by a Custom Setting. The Custom Setting activates items 25 through 30. When a Standard Setting is used items 25 through 30 are set automatically, and cannot be changed.
- 4 To install Custom Message, press flipper button for alphabet and special characters. Press Credit Button for next message letter or character.
- 5 Special Preset Adjustment, whose effects are noted in the Game Adjustment text.
- 6 Refer to **Pricing Table** and text describing these items.
- 7 Approximates Ad 64, yet includes all factors listed in Factory Setting column, not just Ad 31 through 47 provided by Ad 64.

names the respective backbox displays where the information appears, etc.). The Player 3 display shows Ad for all 70 adjustment items, so its entry is omitted from the tabular listing.

The *GAME SHOW* Game Adjustment Setting Comparison Table shows the five game 'difficulty' Adjustment Items (ranging from Ad 62 - Extra Easy through Ad 66 - Extra Hard). Installing any one of these 'difficulty' Adjustments causes the values shown for each of the included game play Adjustment Items to be installed as a group, changing the level of play from one difficulty level to another. The owner/operator can use the information provided by the Audit Table items to determine whether the 'difficulty level' for this game in this location needs to change to obtain a higher level of earnings from the game or to provide a greater challenge to the location's players.

Once the 'difficulty level' is changed, a careful review of the Audit Items will reveal whether the change has achieved this higher-earnings goal. Sometimes, one (or more) of the Adjustment Items needs further change to keep the number of plays high, while still keeping the earnings level high.

GAME SHOW Game Adjustment Comparison Table

Adj #	Adj Description	Extra Easy 62	Ad Easy 63	Medium Ad (Factory) 64	Ad Hard 65	Extra Hard 66
31	Bell Control	Yes	Yes	Yes	Yes	Yes
32	Wheel Rewards All Lit	Yes	Yes	No	No	No
33	Memory Collect	Yes	Yes	Yes	Yes	No
34	Memory Prizes	Yes	Yes	Yes	No	No
35	Memory Top Lane	Yes	Yes	No	No	No
36	Mem. Outhole Extra Ball	Yes	Yes	No	No	No
37	Wheel Time	Yes	Yes	No	No	No
38	5X Time	Yes	No	No	No	No
39	Grand Prize Time	Yes	No	No	No	No
40	Return Lane Spot Letter	Yes	Yes	No	No	No
41	Top Lane Change	Yes	Yes	Yes	Yes	No
42	4 Million Time	Yes	No	No	No	No
43	1st Extra Ball Time	Yes	Yes	Yes	No	No
44	On Outlane Extra Ball	3X	4X	4X	8X	8X
45	Not Used					
46	Consolation Extra Ball	Yes	Yes	Yes	Yes	Yes
47	Consolation Time	45 Sec.	45 Sec.	45 Sec.	45 Sec.	45 Sec.
48	Attract Mode Sound	None	None	None	None	None

Game Adjustment Procedure

Adjustment Items 01 through 70

The coin door must be open to access the Game Adjustment/Diagnostic switches. All readings and setting changes require operation of these coin door switches. Some setting changes utilize the Credit button; Adjustment #49 also uses the flipper buttons. Additional text describing the game adjustment items follows this procedure; the value of the Factory Setting for each Game Adjustment item is in the preceding *GAME SHOW* Game Adjustment Table.

1. Use AUTO-UP and press ADVANCE. The Id 00 display initially appears. Press ADVANCE until the Player 3 display indicates Ad 01. If the factory setting has not changed, the Player 1 and 2 Score displays indicate AUTO REPLAY, and the Player 4 display shows 10%, indicating a 10% replay percentage. (The game program adjusts itself automatically, as discussed in the following text concerning the 'details' about Adjustment Item 01.)
2. To reach a higher item number (in the Player 3 display), use AUTO-UP and press ADVANCE. To return to a previous item number, use MANUAL-DOWN and press ADVANCE.
3. With the desired Game Adjustment Item number showing in the Player 3 display, increase the setting value (or select another option) shown in the Player 4 display by using AUTO-UP and pressing the Credit button. Repeat this step for each item, until all changes to the factory settings for the Game Adjustment Items have been made. The preceding Game Adjustment Table consolidates the Factory Settings into one grouping.

(The same procedure can be used for Audit Items. To zero Au 01 - 04 (concerning the coin chutes and the total coins), the operator can proceed to item 68, Clear Coins, and press the Credit button to obtain the YES option. The operator then presses the ADVANCE button and notes the "DONE" display, which verifies that the entry values for items 01 through 04 of the Audit Items are now reset to zero.)

For example, the operator may desire to change the degree of game play difficulty from the Factory Setting (equivalent to the Install Medium [Ad 64] difficulty, along with a number of other automatically installed settings, as shown in the right column of the Game Adjustment Table) to another difficulty more suitable for the players at a particular game site. Four other 'automatic' play difficulty settings (Ad 62 - Ad 66) are available, each of which, if selected, installs all the adjustments listed for that difficulty in the Game Adjustment Setting Comparison Table, which precedes the 'details' text.

4. To proceed rapidly through the entire adjustments series, press and hold ADVANCE, until Ad 70 shows in the Player 3 display. From item 70, you can: (A) return to the Game-Over Mode; or (B) restore factory settings and zero audit (bookkeeping) totals. Perform either of the following, as desired:

- A. To reach Game-Over Mode, use AUTO-UP and press ADVANCE once. *GAME SHOW* now goes to the Game-Over Mode.
- B. To restore the Factory Settings for Game Adjustment Items (as listed in the Game Adjustments Table), zero all audit (bookkeeping) totals, and return to Game-Over Mode, use AUTO-UP or MANUAL-DOWN to display Ad 70 in the Player 3 display. Press the Credit button to display the YES option in the Player 4 display. Using AUTO-UP, press ADVANCE once. *GAME SHOW* now zeroes ALL Audit Item totals and changes ALL Game Adjustment Items back to those originally selected as Factory Settings. It then shows the operator a message ("FACTORY SETTING") that this has occurred. (A problem in the Memory Protect Circuit or closing the coin door will cause the message "ADJUST FAILURE" to appear.) Press ADVANCE once more to return to the Game-Over Mode.

Details of Adjustment Items 01 through 70

▲ 01 Auto Replay (or Fixed Replay)

Of the two options, AUTO REPLAY is the percentage of replays automatically awarded per game. The game program aids a pinball's initial installation by causing a comparison of the value of the Replay Level to the value of all players' scores every 50 games. At each comparison, the program increases (or decreases) the Replay Level by an amount necessary to achieve the replay percentage specified either via the factory setting or later operator selection. Use the Credit button to change the percentage within the range of 5 to 25 (%), with the value increasing using AUTO-UP (or decreasing using MANUAL-DOWN). The next Credit button change below 5%, selects the FIXED REPLAY option.

For AUTO REPLAY, Ad 02 provides the Starting Replay Level (Player 1 and 2 displays show REPLAY START). Ad 03 provides the number of replay levels (01, 02, 03, or 04). *GAME SHOW* then proceeds to Ad 06 automatically.

For FIXED REPLAY, Ad 02 is the first replay level (REPLAY LEVEL 1). Ad 03, 04, and 05 are the other replay levels.

▲ 02 Starting Replay Level (or Replay Level 1)

For AUTO REPLAY (refer to Ad 01), the initial Factory Setting is listed in the Game Adjustment Table. The range of settings is 800,000 through 9,800,000 (by increments of 100,000 with AUTO-UP or decrements of 100,000 with MANUAL-DOWN).

For FIXED REPLAY, the operator can enter the value to be used for the first fixed replay score level via the Credit button. The range of settings is: OFF; 100,000 through 9,900,000 (by increments of 100,000 with AUTO-UP, or decrements of 100,000 with MANUAL-DOWN).

▲ 03 Replay Levels (or Replay Level 2)

For AUTO REPLAY (refer to Ad 01), this is the number of replay levels in a game. The option range is one, two, three, or four replay level(s). When the operator chooses two replay levels, *GAME SHOW* automatically adjusts the second replay level to be twice the value selected for Ad 02, the starting replay level. Choosing three or four replay levels automatically adjusts their replay levels to three times or four times the Ad 02 value.

For FIXED REPLAY, the technique of value entry and the range of settings are identical to those of Ad 02.

▲ 04 (Replay Level 3)

For AUTO REPLAY, this Adjustment Item is not applicable. *GAME SHOW* automatically bypasses this adjustment.

For FIXED REPLAY, the technique of value entry and the range of settings are identical to those of Ad 02.

▲ 05 (Replay Level 4)

For AUTO REPLAY, this Adjustment Item is not applicable. *GAME SHOW* automatically bypasses this adjustment.

For FIXED REPLAY, the technique of value entry and the range of settings are identical to those of Ad 02.

▲ 06 Replay Award

For either AUTO REPLAY or FIXED REPLAY (Ad 01), the operator can select the form of the award automatically provided when the player exceeds any Replay Level (Automatic or Fixed). The choices are:

- Credit - Reaching each replay level obtains a credit (free game).
- Ball - Reaching each replay level obtains an extra ball.
- Audit - Reaching each replay level obtains nothing to the player; it does increase the entry value of the Audit Item(s) maintaining a tally of these awards (Au 08, and Au 20 through 23, as applicable).

▲ 07 Special Award

The operator can select the form of the award automatically provided when the player scores a Special. The choices are:

- Credit - Scoring each Special, when lit, obtains a credit (free game).
- Ball - Scoring each Special, when lit, obtains an extra ball.
- Score - Scoring each Special, when lit, obtains a score advance of 100,000 points to the player.

▲ 08 Match Award

The operator can select (via the Credit button) the desired percentage for the Match action occurring at the completion of each game. The choices are:

- 1%-50% - 1% is 'hard'; 50% is 'extremely easy'. During Match action, the game selects a random two-digit number at end of game and compares each player's score for an identical two digits in the rightmost two positions. A matching of the two digits results in the award of a credit.
- Off - The MATCH display does not operate at completion of the game; no award is given.

▲ 09 Balls/Game

The operator can define a "game" by specifying the number of balls to be played. The range of this setting is 1 through 9.

▲ 10 Tilt Warning

The operator can specify the number of total actuations of the plumb bob and playfield tilt mechanisms that can occur before the game is "tilted". The range of this setting is 1 through 5.

▲ 11 Maximum Extra Ball

The operator can choose (via the Credit button) the number of Extra Balls to be awarded to a player. The range of this setting is:

- 00 - NO extra ball play: displays a message, NO EX. BALL
A score is awarded in lieu of the extra ball.
- 1-9 E.B./Ball - 1 through 9 Extra Balls per ball (i.e., all balls including Extra Balls) are awarded.

▲ 12 Maximum Credits

The operator can specify the maximum number of credits the game can accumulate, either through game play awards or coin purchases. The range of settings is 5 through 10. Reaching the specified setting prevents the award of additional credits by game play. Coin purchases do continue to accumulate and are displayed.

▲ 13 Highest Scores

The operator can specify (via the Credit button) whether the game is to maintain a record of the four highest scores achieved to date. The choices are:

- Off - NO high scores are recorded.
- On - The four highest scores are stored in memory for use by Game Adjustment 22.

▲ 14 Backup High Score 1

The operator can set the Backup High Score value in the Player 1 Score display, using the Credit button. The game automatically restores this value, when the operator presses, and holds, the HIGH SCORE RESET switch, or when an automatic High Score Reset event (Ad 22) occurs.

▲ 15 Backup High Score 2

This adjustment is similar to Ad 14, except that this applies to the Player 2 Score display. The adjustment technique is identical to Ad 14. It is also restored as described for Ad 14.

▲ 16 Backup High Score 3

This adjustment is similar to Ad 14, except that this applies to the Player 3 Score display. The adjustment technique is identical to Ad 14. It is also restored as described for Ad 14.

▲ 17 Backup High Score 4

This adjustment is similar to Ad 14, except that this applies to the Player 4 Score display. The adjustment technique is identical to Ad 14. It is also restored as described for Ad 14.

▲ 18 Credits for Highest Score 1

The operator can select the number of credits to be awarded, by using the Credit button, whenever a player exceeds the previous Highest Score. The range of this setting is 00 through 10.

▲ 19 Credits for Highest Score 2

This adjustment is similar to Ad 18, except that this applies to the player's exceeding the second highest score. The Credit button adjustment technique is the same as for Ad 18. The range of this setting is 00 to 03.

▲ 20 Credits for Highest Score 3

This adjustment is similar to Ad 18, except that this applies to the player's exceeding the third highest score. The Credit button adjustment technique is the same as for Ad 18. The range of this setting is 00 through 03.

▲ 21 Credits for Highest Score 4

This adjustment is similar to Ad 18, except that this applies to the player's exceeding the fourth highest score. The Credit button adjustment technique is the same as for Ad 18. The range of this setting is 00 through 03.

▲ 22 Automatic High Score Reset

The operator can specify (via Credit button) that the game will provide an automatic reset of the displayed "Highest Scores", and the number of games to be played before the reset occurs. (Audit item 39 displays the games remaining before the reset.) The values provided upon reset are those selected by the operator in Ad 14 through 17, the Backup High Scores. The range of this setting is Off (to disable this adjustment), and 250 to 24,750 games (in increments of 250).

▲ 23 Free Play

The operator can select (via the Credit button) whether a player can operate the game without a coin (free play) or with a coin. The choices are:

- No - A coin is necessary for game play.
- Yes - Game play is free; no coin is required.

▲ 24 Coinage Selections

The operator can specify (via the Credit button) any of the Standard Settings for game pricing, each of which exhibits a message identifying the country and the number of coins required and the number of games that the coin requirement purchases. Choosing a Standard Setting permits the game to omit items Ad 25 through 30, which are adjustments allowing for a special custom coinage setting.

Following the last Standard Setting is a Custom Coinage Setting, which allows the operator to utilize Ad 25 through 30 in establishing a special coinage setting. A message, CUSTOM COINAGE, indicates that the operator can enter the appropriate values into the Ad 25 through 30 adjustment items.

The values for Ad 25 through 30 of each Standard Setting, as well as other possible values for the Custom Coinage Setting are shown in the Pricing Table.

▲ 25 Left Chute Coin Units

The operator can specify (via the Credit button) the number of coin units purchased by a coin passing through the left coin chute.

▲ 26 Center Chute Coin Units

The operator can specify (via the Credit button) the number of coin units purchased by a coin passing through the center coin chute.

▲ 27 Right Chute Coin Units

The operator can specify (via the Credit button) the number of coin units purchased by a coin passing through the right coin chute.

▲ 28 Units Required for Credit

The operator can define (via the Credit button) the number of coin units required to obtain 1 Credit. A coin unit counter in the game program totals the number of coin units purchased through all coin chutes prior to each game. If the total of these coin units matches, or exceeds, the Units per Credit value by a multiple (or more, coin units) of the specified Units per Credit value, the Credits display shows the proper number of Credits. The coin unit counter retains any remaining coin units, until the start of a game; then, the coin unit counter is cleared (its contents are zeroed).

▲ 29 Units Required for Bonus

The operator can specify (via the Credit button) that 1 additional Credit is to be indicated in the Credits display, when a certain number of coin units are accumulated.

▲ 30 Minimum Units Required for any Credits Posted

The operator can specify that NO Credits are to be posted (indicated in the Credits display), until the credit units counter reaches a particular value, by setting this value to 02 (or more). A setting of 01 allows the Credits display to show fractional coin units.

The System 11B game program defines the following Adjustment Items as "game specific"; that is, they are unique for each game. The Game Designer/Engineer/Programmer team members work together to use these as controlling factors for game play. By varying the setting of these Adjustment Items, it is possible to "fine-tune" a game to suit a particular location, enabling the owner/operator to reap maximum earnings, while still providing the players with sufficient challenge to keep them playing.

▲ 31 Bell Control

The operator can choose (via the Credit button) whether or not the Bell rings during game play. The choices are:

Yes - (Liberal) The Bell does ring during game play.

No - (Conservative) The Bell does not ring during game play.

▲ 32 Wheel Rewards

The operator can choose (via the Credit button) whether or not the Wheel Reward lights are lit at ball start. The choices are:

Yes - (Liberal) All Wheel Reward Lights are lit at ball start.

No - (Conservative) The Wheel Reward Lights are reset at ball start.

▲ 33 Collect Lights Memory

The operator can choose (via the Credit button) whether the Collect Lights are stored in memory for "next ball" play (continues from ball to ball) or are reset for each ball. The choices are:

Yes - (Liberal) The Collect Lights are remembered from ball to ball.

No - (Conservative) The Collect Lights are reset at ball start.

▲ 34 Prize Lights Memory

The operator can choose (via the Credit button) whether the Prize Lights are stored in memory for "next ball" play (continues from ball to ball) or are reset for each ball. The choices are:

Yes - (Liberal) The Prize Lights are remembered from ball to ball.

No - (Conservative) The Prize Lights are reset at ball start.

▲ 35 Top Lane Lights Memory

The operator can choose (via the Credit button) whether the Top Lane Lights are stored in memory for "next ball" play (continues from ball to ball) or are reset for each ball. The choices are:

Yes - (Liberal) The Top Lane Lights are remembered from ball to ball.

No - (Conservative) The Top Lane Lights are reset at ball start.

▲ 36 Extra Ball Memory

The operator can choose (via the Credit button) whether the Extra Ball via the Outlane Lights are stored in memory for "next ball" play (continues from ball to ball) or are reset for each ball. The choices are:

Yes - (Liberal) The Extra Ball Lights are remembered from ball to ball.

No - (Conservative) The Extra Ball Lights are reset at ball start.

▲ 37 Wheel Time

The operator can choose (via the Credit button) whether to allow the player more time to achieve the Wheel. The choices are:

- Yes - (Liberal) The player is allowed more time to achieve the Wheel.
- No - (Conservative) The player is not given more time.

▲ 38 5X Wheel Time

The operator can choose (via the Credit button) whether to allow the player more time to achieve the 5X Wheel. The choices are:

- Yes - (Liberal) The player is allowed more time to achieve the 5X Wheel.
- No - (Conservative) The player is not allowed more time.

▲ 39 Grand Prize Time

The operator can choose (via the Credit button) whether to allow the player more time to achieve the Grand Prize. The choices are:

- Yes - (Liberal) The player is allowed more time to achieve the Grand Prize.
- No - (Conservative) The player is not allowed more time.

▲ 40 Spot Return Lane

The operator can choose (via the Credit button) whether or not the Return Lanes spot a Letter. The choices are:

- Yes - (Liberal) The Return Lanes spot a Letter.
- No - (Conservative) The Return Lanes do not spot a Letter.

▲ 41 Top Lane Change

The operator can choose (via the Credit button) whether the player is able, via the flippers, to rotate the Top Lanes Lights. The choices are:

- Yes - (Liberal) The player can use the flippers to rotate the Top Lanes Lights.
- No - (Conservative) The player cannot rotate the Top Lanes Lights.

▲ 42 4 Million Time

The operator can choose (via the Credit button) whether to allow the player more time to achieve 4 Million. The choices are:

- Yes - (Liberal) The player is allowed more time to achieve 4 Million.
- No - (Conservative) The player is not allowed more time.

▲ 43 First Extra Ball Time

The operator can choose (via the Credit button) whether the First Extra Ball Light stays lit for the duration of the current ball. The choices are:

- Yes - (Liberal) The 1st Extra Ball Light does stay lit for the duration of the current ball.
- No - (Conservative) The 1st Extra Ball Light does not stay lit for the duration of the current ball.

▲ 44 Outlane Extra Ball

The operator can choose (via the Credit button) when the Outlane Extra Ball lights. The choices are:

- Easy - (Liberal) 3X
- Medium - 4X
- Hard - (Conservative) 8X

▲ 45 Not Used

▲ 46 Consolation Extra Ball

The operator can choose (via the Credit button) whether a less-skilled player can obtain an Extra Ball. The choices are;

- Yes - (Liberal) With a ball time less than the setting of Ad 47, the player receives an opportunity to obtain an Extra Ball.
- No - (Conservative) The player cannot receive an Extra Ball.

▲ 47 Average Ball Time

The operator can choose (via the Credit button) the minimum game time below which a form of 'consolation' becomes effective. This compensates for less skilled players to encourage them to continue to play the game. Factory setting is 45 seconds.

▲ 48 Attract Mode Sounds

The operator can select (via the Credit button) the frequency of attract mode sounds. The choices are:

- Alot - (Liberal) Sounds Are active most of the time.
- Less - Sounds are active some of the time.
- None - (Conservative) No sound at all during attract mode.

▲ 49 Custom Message

The operator can choose (via the Credit button) whether to display a message during the Attract Mode. (When display of a message is selected, the operator can either utilize the message provided or change the message). Three choices are available:

- 1 - Display a message during the Attract Mode. The Player 4 display shows this choice as ON. The message provided is:
COME ON DOWWWN, WIN A NEW CAR AND BIG BUCKS
- 2 - Do NOT display a message during the Attract Mode. (Player 4 shows OFF.)
- 3 - The Player 4 display shows this choice as CHANGE. The operator can enter a special ("custom") message, as follows:
 - A. Press ADVANCE once. The operator can now enter as many as three 14-character lines for display during the Attract Mode.
 - B. Use the flipper button(s) to select each message character (alphabet, numbers, and special symbols are available). In case of error, enter a "back arrow" (just before "space") to correct, followed by correct character. For a period after any letter, use letters with periods (following the special symbols). The entire character set is the following:

A B C D E F G H I J K L M N O P Q R S T U V W X Y Z 0 1 2 3 4 5 6 7 8 9 < > ? - / * ' ,

A. B. C. D. E. F. G. H. I. J. K. L. M. N. O. P. Q. R. S. T. U. V. W. X. Y. Z. _

- C. Move to the next character via the Credit button. No entirely blank lines will be displayed.

▲ 50 Display AU 01 - 04

The operator can choose (via the Credit button) how to display the coinage audit information, Au 01 - 04. No information is lost; it remains stored in the CPU memory. The information is now available for readout via the player score displays. Three choices are available:

- Yes - Both the audit text (slot identification) and the value is displayed.
- Value - Only the value is displayed.
- No - NO display occurs.

▲ 51-52 Not Used

▲ 53-55 Not used in USA games (see Adjustments for German games).

SPECIAL PRESET ADJUSTMENTS CAUTION

Adjustments 53 through 66 are Special Preset Adjustments to enable the operator to perform the setting of multiple adjustments at once. They permit the operator to: (1) either modify a game for a specific area (for example, USA coinage settings, Ad 56 through 58, or special German coinage settings, Ad 53 through 58) (2) change a group of adjustments to conform with laws of certain localities (Ad 59 through 61); and (3) to change the degree of difficulty of game play (Ad 62 through 66). A list of the preceding individual Adjustments affected accompanies each of these Special Preset Adjustments. Whenever the operator chooses to use any Special Preset Adjustment, the operator can later access any or all of the individual Adjustments affected by that Special Adjustment for subsequent changes.

A similar technique is recommended in the event of error or uncertainty concerning any Special Preset Adjustment, after the operator selects it: The operator can restore the factory setting of each individual Adjustment, then select the desired Special Preset Adjustment, and then return to any of the preceding individual adjustments to determine whether use of the Special Adjustment has had the desired effect.

The Backbox displays for each Special Preset Adjustment indicate whether the operator has selected it, by identifying the Adjustment in the Player 1 and 2 displays by name and the selection choice of NO, meaning Not Selected (this is the Factory Setting), or YES, meaning Selected, in the Player 4 display. Operator installation of the 'selected' Preset Adjustment occurs by using the Credit button to choose YES and then pressing the ADVANCE switch. The displays then show the name of the Adjustment again, with DONE to show that the installation is now in effect.

Note that, when an operator installs any of the Special Preset Adjustments, Adjustment Items using the automatic adjust feature of the game program reset to the auto adjust value listed for that Adjustment Item.

NOTE

Games in which the CPU has ROMs installed for German (Deutsch) language and play adjustments automatically have certain Adjustment Items preset. The following table shows these Preset Adjustment Items for each of the special German Coinage Adjustments.

▲ 53 Through 58 FOR GERMAN/EUROPEAN GAMES ONLY:

Install German 1, 2, 3, 4, 5 or 6

The operator can use these Adjustment Items to modify the game pricing selection of Standard Setting named "German 2 or German 1" in the Pricing Table to permit the style of play for the particular price shown in the *GAME SHOW* Preset Game Adjustments Table for German/European Games.

Preset Game Adjustments Table For **GERMAN/EUROPEAN GAMES**

AD	ADJ DESCRIPTION	GERMAN 1	GERMAN 2	GERMAN 3	GERMAN 4	GERMAN 5	GERMAN 6
		AD 53	AD 54	AD 55	AD 56	AD 57	AD 58
06	Replay Award	Credit	Coil	Audit	Credit	Coil	Audit
07	Special Award	Credit	Ball	Score	Credit	Ball	Score
08	Match Feature	7%	7%	Off	7%	7%	Off
09	Balls/Game	03	03	03	03	03	03
14	Backup High Score 1	8,500,000	8,500,000	00	8,500,000	8,500,000	00
15	Backup High Score 2	8,000,000	8,000,000	00	8,000,000	8,000,000	00
16	Backup High Score 3	7,500,000	7,500,000	00	7,500,000	7,500,000	00
17	Backup High Score 4	7,000,000	7,000,000	00	7,000,000	7,000,000	00
18	High Score 1 Credits	03	03	00	03	03	00
19	High Score 2 Credits	00	00	00	00	00	00
20	High Score 3 Credits	00	00	00	00	00	00
21	High Score 4 Credits	00	00	00	00	00	00
24	Coinage Setting	6 spiele/5 DM	6 spiele/5 DM	6 spiele/5 DM	7 spiele/5 DM	7 spiele/5 DM	7 spiele/5 DM

▲ 56 Install 3 Balls/2 Coins

The operator can use this adjustment to modify the current game pricing selection to enable game play to begin when the specified number of coins are deposited. In this instance, the player now receives a 3 ball game when 2 coins of proper denomination (USA: 50 cents) passes through the coin chute.

▲ 57 Install 3 Ball/ 1 Coin

The operator can use this adjustment to modify the current game pricing selection to enable game play to begin when the specified number of coins are deposited. In this instance, the player now receives a 3 ball game when 1 coin of the proper denomination (USA: 25 cents) passes through the coin chute.

▲ 58 Install 5 Balls/2 Coins

The operator can use this adjustment to modify the current game pricing selection to enable game play to begin when the specified number of coins are deposited. In this instance, the player now receives a 5 ball game when 2 Coins of the proper denomination (USA: 50 cents) passes through the coin chute.

Preset Game Adjustments Table For US/CANADIAN GAMES

AD	ADJ DESCRIPTION	AD 54 Not Used	AD 55 Not Used	AD 56 3-ball/ 2 Coins	AD 57 3-balls/ 1 Coin	AD 58 5-balls/ 2 Coins
02	Replay Start	-	-	4,500,000	4,500,000	5,500,000
09	Balls/Game	-	-	3	3	5
14	Backup High Score 1	-	-	8,000,000	8,000,000	9,000,000
15	Backup High Score 2	-	-	7,500,000	7,500,000	8,500,000
16	Backup High Score 3	-	-	7,000,000	7,000,000	8,000,000
17	Backup High Score 4	-	-	6,500,000	6,500,000	7,500,000
24	Coinage	-	-	USA 3	USA 1	USA 3
64	Install Medium	-	-	Yes	Yes	No
65	Install Hard	-	-	No	No	Yes

▲ 59 Install Add-A-Ball

The operator can utilize this option to delete all Free Play awards and replace them with Extra Ball awards. Individual Adjustments are affected, as follows:

<u>Ad</u>	<u>Name</u>	<u>New Setting</u>	<u>Ad</u>	<u>Name</u>	<u>New Setting</u>
06	Replay Award	Ball	18	Hi Scr 1 Credits	00
07	Special Award	Ball	19	Hi Scr 2 Credits	00
08	Match Feature	Off	20	Hi Scr 3 Credits	00
11	Ex. Ball	4/BIP	21	Hi Scr 4 Credits	00

▲ 60 Install 5-Ball

The operator can change the game to 5-ball play, including the changing of certain features to the recommended 5-ball difficulty level. NOTE Ad 65 (Install Hard) settings are also set when the game is changed to '5-ball play'. Individual Adjustments are affected, as follows:

<u>Ad</u>	<u>Name</u>	<u>New Setting</u>	<u>Ad</u>	<u>Name</u>	<u>New Setting</u>
02	Replay Start	7,000,000	09	Balls/Game	05

▲ 61 Install Novelty

The operator can remove all Free Play and Extra Ball awards. Individual Adjustments are affected, as follows:

<u>Ad</u>	<u>Name</u>	<u>New Setting</u>	<u>Ad</u>	<u>Name</u>	<u>New Setting</u>
01	Fixed Replay	Scores	07	Special Award	Score
02	Replay Level 1	Off	08	Match Feature	Off
03	Replay Level 2	Off	11	No Extra Ball	00
04	Replay Level 3	Off	18	Hi Scr 1 Credits	00
05	Replay Level 4	Off	19	Hi Scr 2 Credits	00
06	Replay Award	Audit	20	Hi Scr 3 Credits	00
			21	Hi Scr 4 Credits	00

▲ 62 Install Extra Easy

The operator can change the game play difficulty adjustments to a combination that is extremely easy (sometimes called "liberal"). The Game Adjustment Setting Comparison Table, which precedes these 70 individual Adjustment descriptions, lists the Adjustments and the settings that comprise the 'Extra Easy' group.

▲ 63 Install Easy

The operator can change the game play difficulty adjustments to a combination that is slightly easier than the Factory Settings. The Game Adjustment Setting Comparison Table, which precedes these 70 individual Adjustment descriptions, lists the Adjustments and the settings that comprise the 'Easy' group.

▲ 64 Install Medium

The operator can change the game play difficulty adjustments to a combination that matches the Factory Settings. The Game Adjustment Setting Comparison Table, which precedes these 70 individual Adjustment descriptions, lists the Adjustments and the settings that comprise the 'Medium' group.

▲ 65 Install Hard

The operator can change the game play difficulty adjustments to a combination that is more difficult than the Factory Settings. The Game Adjustment Setting Comparison Table, which precedes these 70 individual Adjustment descriptions, lists the Adjustments and the settings that comprise the 'Hard' group.

▲ 66 Install Extra Hard

The operator can change the game play difficulty adjustments to a combination that is much more difficult than the Factory Settings. The Game Adjustment Setting Comparison Table, which precedes these 70 individual Adjustment descriptions, lists the Adjustments and the settings that comprise the 'Extra Hard' group.

▲ 67 Auto Burn-in

The operator can choose the YES option for this Special Preset Adjustment to perform certain automatic testing of the game, as used in the factory. It does not affect the game operation, but merely provides for a cycle testing of most of the game's mechanisms.

▲ 68 Clear Coins

The operator can request the clearing of the coinage audits (Au 01 through 04) by selecting (via the Credit button) the YES option, as shown in the player 4 display. This adjustment zeroes the counters tallying the number of coins through each slot, the Paid Credits counter, and the Credits display.

After the YES option is displayed, the operator must press the ADVANCE button. The game then displays DONE to show that the coinage audits have been reset to zero.

▲ 69 Clear Audits

The operator can request the clearing of the non-coinage audits (Au 05 through 55) by selecting (via the Credit button) the YES option, as shown in the player 4 display. This Adjustment zeroes the counters tallying the remaining Audit factors. Please note that this does NOT affect the Automatic Replay Percentaging data nor the automatic High Score Reset counter.

After the YES option is displayed, the operator must press the ADVANCE button. The game then displays DONE to show that the non-coinage audits have been reset to zero.

▲ 70 Install Factory

The operator can request the game (via the Credit button) to provide the normal Factory Settings, essentially restoring the game to its 'factory condition'. The operator must select the 'YES' option for this adjustment. This Adjustment clears all Audits, resets all Game Adjustments to the respective Factory Settings, and provides a restart of the Auto Replay (Ad 01). After selecting the YES option, the operator must press the ADVANCE button. The game then displays FACTORY SETTING.

Closing of the coin door before appearance of the FACTORY SETTING message or a problem in the Memory Protect Circuit will cause the game to display ADJUST FAILURE.

A loss of battery power or improper treatment of the Game Adjustments will cause the game to attempt to restore Factory Settings. The game announces the results of this reset process with the appropriate message, FACTORY SETTING or ADJUST FAILURE.

Resetting the High Scores

The challenge of exceeding the High Score (either the factory setting or a higher score by another player) is the goal of many pinball game players. To keep a pinball game challenging requires a method of resetting the High Score value for those occasions when a skilled player registers a truly excellent score. Other players note this score and may decide not to play simply because their skill is not adequate to exceed an extremely high score.

For *GAME SHOW*, in fact, three methods of resetting the High Score values are available. The simplest method involves allowing Game Adjustment Item Ad 22 to reset the High Score values automatically after the specified number of plays designated by the operator. The second method requires pressing the High Score Reset switch on the inside of the coin door in the Attract Mode. This action simply erases the previous high score values and replaces them with the Backup High Score values. The third method establishes new values replacing the factory setting values or previous operator setting values; it requires performing the following steps:

1. Using AUTO-UP or MANUAL-DOWN, reach item Ad 14 (and items Ad 15, 16, and 17, if desired). The High Score value of the factory setting (or previous operator-adjusted setting) appears in the Player 1 display. If this value is satisfactory, go to step 4 below.
2. If you wish to increase the High Score value from that displayed in the Player 1 display, use AUTO-UP, and press the Credit button, until the desired value shows in the Player 1 display.
3. If you wish to decrease the High Score value, use MANUAL-DOWN, and press the Credit button, until the desired value shows in the Player 1 display.
4. Using AUTO-UP, press and hold down ADVANCE, until the Player 3 display shows Ad 70 Press ADVANCE once, to return to Game-Over Mode.
5. Press the High Score Reset switch (on coin door), and listen for the sound signifying that the score reset action is complete. Observe player score displays (Player 1, Player 2, etc.) to verify that the new High Score values are displayed.

Game Pricing

PRICING MADE EASY

Game Adjustment Item Ad 24 allows the operator an easy method of setting the pricing functions. Pressing the Credit button allows the operator a choice of one of the 16 "Standard" Settings, with associated automatic pricing (Player 1 and 2 displays show the Country identifier, with a number for a country having more than one "Standard" Setting; player 3 and 4 displays show the games per coin(s) information). In the Pricing Table, each "Standard" Setting is denoted by a Country Identifier. Automatic Pricing causes each of the other pricing items (columns 25 through 30) to change to the value shown in the table for that selected "Standard" Setting. In the table where the word "CUSTOM" appears, the owner/operator must enter the values shown (columns 25 through 30) to obtain the games per coin factor shown in the Games/Coin column of the table. To make these setting adjustments, the owner/operator must press the Credit button until the words "CUSTOM COINAGE" appear in the player score displays.

GAME SHOW Pricing Table

Country	Coin Chute			Games/Coin	Ad 24 Display	Pricing Functions					
	Left	Center	Right			25	26	27	28	29	30
USA and Canada	25¢	-	25¢	1/25¢, 4/\$1 ²	U.S.A. 1	01	04	01	01	00	00
				1/50¢, 2/75¢, 3/\$1 ^{1,2}	U.S.A. 2	03	12	03	04	00	00
				1/50¢, 2/\$1 ²	U.S.A. 3	01	04	01	02	00	01
				1/25¢, 3/\$1 ²	U.S.A. 4	01	00	01	02	04	01
				1/25¢, 3/50¢, 6/\$1	CUSTOM	01	04	01	01	02	00
				1/25¢, 5/\$1	CUSTOM	01	00	01	01	04	00
Austria				1/50¢ ; Add'l game: 25¢	CUSTOM	98	00	98	99	00	00
	5 Sch	10 Sch	10 Sch	1/2x5 Sch, 3/2x10 Sch ²	AUSTRIA	01	02	02	02	04	01
	5 Sch	-	10 Sch	2/5 Sch, 5/10 Schilling	CUSTOM	02	00	05	01	00	00
	1 Sch	5 Sch	10 Sch	2/5x1 Sch, 2/5 Sch, 5/10 Sch	CUSTOM	02	10	25	05	00	00
Australia	20¢	-	\$1	1/3x20¢, 2/\$1 ²	AUSTRAL.	02	00	10	05	00	00
United Kingdom	10 P	50 P	1£	1/2x10 P, 3/50 P, 7/1£ ²	U.K.	03	15	30	05	30	00
	10 P	50 P	20 P	1/10 P, 5/50 P, 2/20 Pence	CUSTOM	03	15	30	05	30	00
Switzerland	1 F	2 F	5 F	1/1 F, 3/2 F, 7/5 Franc ²	SWISS	01	03	07	01	00	00
	1 F	-	2 F	1/1 F, 3/2 F	CUSTOM	03	00	06	02	00	00

GAME SHOW Pricing Table (Continued)

Country	Coin Chute			Games/Coin	Ad 24 Display	Pricing Functions					
	Left	Center	Right			25	26	27	28	29	30
Belgium	20 F	20 F	20 F	3/20 Franc ²	BELGIUM	03	03	03	01	00	00
	5F	-	20 F	1/2x5 F, 2/20 Franc	CUSTOM	01	00	04	02	00	01
	5F	20 F	20 F	1/2x5 F, 2/20 F, 2/20 F	CUSTOM	01	04	04	02	00	01
	5F	5F	20 F	1/2X5 F, 1/2X5 F, 2/20 F	CUSTOM	01	01	04	02	00	01
West Germany	1 DM	2 DM	5 DM	1/1 DM, 2/2 DM, 7/5 DMark ^{2,3}	GERMAN1	06	12	30	05	30	00
				1/1 DM, 2/2 DM, 6/5 DM ^{1,2}	GERMAN2	06	12	30	05	00	00
				1/1 DM, 3/2 DM, 9/5 DM	CUSTOM	09	18	45	05	00	00
				1/2x1 DM, 1/2 DM, 3/5 DM	CUSTOM	03	06	15	05	00	00
				2/1 DM, 5/2 DM, 14/5 DM	CUSTOM	13	26	65	05	65	00
Netherlands	1 Hfl	2.5 Hfl	2.5 Hfl	1/1 Hfl, 3/2.5 Holland Florin ²	NETHERL.	06	15	15	05	00	00
	25¢	-	1 G	1/25¢, 5/1 Guilder	CUSTOM	01	00	05	01	00	00
	1G	-	1 G	1/1 Guilder ²	HOLLAND	01	00	01	01	00	00
Sweden	5 Kr	5 Kr	5 Kr	1/5 Krona ²	SWEDEN	01	01	01	01	00	00
	1 Kr	-	1 Kr	1/2x1 Krona	CUSTOM	01	04	01	02	00	01
France	1 F	5 F	10 F	1/3x1 F, 2/5 F, 5/10 Franc ^{1,2}	FRANCE	02	10	20	05	20	00
	1 F	5 F	10 F	1/2x1 F, 3/5 F, 7/10 Franc	CUSTOM	03	15	30	05	30	00
	5 F	10 F	10 F	1/5 F, 3/10 F, 7/2x10 Franc	CUSTOM	03	15	30	10	60	15
	5 F	10 F	10 F	2/5 F, 4/10 F, 9/2x10 Franc	CUSTOM	02	10	20	05	40	10
	5 F	10 F	10 F	2/5 F, 5/10 F, 11/2x10 Franc	CUSTOM	01	05	10	02	20	05
Italy	500 L	500L	500 L	1/500 Lire ²	ITALY	01	01	01	01	00	00
Spain	25 P	-	100P	1/25 P, 5/100 Peseta ²	SPAIN	05	00	20	04	00	00
	25 P	-	100P	1/25 P, 4/100 Peseta	CUSTOM	01	00	04	01	00	00
	25 P	-	100P	1/2x25 P, 2/100 Peseta	CUSTOM	01	00	04	02	00	00
	25 P	-	100P	1/2x25 P, 3/100 Peseta	CUSTOM	03	00	12	04	00	06
Japan	100 ¥	-	100 ¥	1/100 Yen ²	JAPAN	01	00	01	01	00	00
	-	100 ¥	-	2/100 ¥	CUSTOM	01	04	01	02	00	01
Antilles, Netherl.	25¢	-	1 G	1/25¢, 4/1 Guilder ²	ANTILLES	01	01	04	01	00	00
Chile	Token	-	Token	1/1 Token ²	CHILE	01	04	01	01	00	00
Denmark	1 Kr	5 Kr	10 Kr	1/2x1 Kr, 3/5 Kr, 7/10 Krone ²	DENMARK	03	15	30	05	30	00
Finland	1 Mka	-	5 Mka	1/2x1 Mka, 3/5 Markka ²	FINLAND	03	00	15	05	00	00
New Zealand	20¢	-	20¢	1/3x20¢ ²	N. Z.	01	00	01	03	00	01
Norway	1 Kr	-	1 Kr	1/2x1 Kr, 3/5x1 Krone ²	NORWAY	01	00	01	02	05	00
Argentina	10¢	10¢	10¢	1/1 Token ²	ARG.	01	01	01	01	00	00
Greece	10D	20D	50D	1/2x10D, 1/20D, 3/50 Drachma ²	GREECE	03	06	15	05	00	00

Notes:

1. Factory Default. 2. Standard Setting - Change by pressing Credit button. 3. Other functions are also affected; see the explanation for adjustment Items 53 through 58.

CUSTOM PRICING

Adjustment Item 24 must be set to the Custom Coinage Setting (player 1 and 2 displaying CUSTOM COINAGE) to enable the operator to enter desired custom pricing selections for Items 25 through 30, based on the Pricing Table. Item 25 is the left coin chute multiplier. Item 26 is the center coin chute multiplier. Item 27 is the right coin chute multiplier. Item 28 is the number of coin units equal to one Credit. (A Credit is usually equal to one game.)

The calculation of the ratio of Games : Price uses the ratio equation of $X : VC$, where:

X = Coin Chute Multiplier (Item 25, 26, or 27 in Pricing Table);

V = Value of coin;

C = Coin units equivalent to one Credit (Item 28).

For example, for 25¢ chutes at the factory setting, substituting values in the Games : Price ratio calculation gives $1 : 25 \times 1$, or one game for 25¢.

UNITS REQUIRED FOR BONUS CREDIT

Item 29 is the number of coin units that must pass through the coin chute(s) before an additional Credit (game) is posted (displayed). At the factory setting, the number in this item is 00. (This 00 means that NO bonus credit [free game] is awarded, although purchase of more than one game at a time occurs.)

MINIMUM COIN UNITS

Item 30 determines the number of coin units that must pass through the coin chute(s) before play may begin. The Factory Setting for this item is 00. (This 00 means that the Minimum Coin Units feature (Item 30) is disabled; a 01 setting also means that this feature is still disabled, yet the Credits message display should display fractional coin units.)

Test/Diagnostic Procedures

GAME SHOW provides a series of diagnostic tests to aid the operator in determining game condition (that is, whether the game's features and highlights are operating satisfactorily). These tests activate virtually all the electronic and electromechanical devices comprising the game, so that the operator can readily locate a malfunctioning device or simply verify that all devices are working properly. In order, these tests deal with the music, the displays, the lamps, the solenoids, the switches and the A/C select relay (C-side test).

In addition to the diagnostic testing, a feature called the Auto Burn-in Mode is available. Activating this mode enables the operator to observe the game while all of the diagnostic tests, except the switch test, occur. This can be very helpful in locating 'intermittent' problems.

Activating either the entire test series or one of the individual tests requires use of the Game Adjustment/ Diagnostic switches. Open the coin door for access to these switches. To proceed to the Diagnostic Tests, the operator must simply switch the game On, set the AUTO-UP/MANUAL- DOWN switch to MANUAL-DOWN, and press the ADVANCE button.

Caution

The System-11B game program greatly aids the operator and service personnel: At the beginning of the Test/Diagnostic Procedures (and also at game Turn-On), the player score displays now signal, with a message ("Press ADVANCE for Report") that at least one switch has NOT been actuated during ball play for a lengthy period of time (90 balls, or 30 games). Moreover, the Problem Reporting activity at the beginning of the Test/ Diagnostic Procedures, the display of problem switches now includes ALL switches exhibiting problems. Refer to the text on Switch Tests for additional information. To proceed with the Test/Diagnostic Procedures, use AUTO-UP, and press ADVANCE.

MUSIC TEST

1. In the Music Test, observe that the player 1 and 2 displays show the message, MUSIC TEST. Switching to AUTO-UP, observe that the message now reads MUSIC OFF, and that the player 3 score display shows 00 00. Press the Credit button to select the desired music selection: 01 - 'Main Theme' through 07 - CVSD Speech (the selections repeat). Adjust the volume control for proper sound level for the game location.
2. Use the AUTO-UP position to proceed to the next test.

DISPLAY TEST

1. To initiate the Display Test, press ADVANCE. Observe that player 1 and 2 displays briefly show the message, DISPLAY TEST, and that the player 3 score display shows 01 (the Display Test identifier).
2. Use AUTO-UP. Observe that all displays begin a display cycle of all 0s through all 9s, one digit at a time. Verify that the proper comma segments light during display of the odd-numbered digits. Next, a special "all segments" character 'walks' from left to right across each player score display.
3. To halt the display cycle, use MANUAL-DOWN. Then, press ADVANCE to step through the sequential digit display, digit by digit, and the subsequent "all segments" characters display test. Use AUTO-UP to resume cycling, and to proceed to the next test.

LAMP TESTS

1. All Lamps

(From Display Test) To initiate the first Lamps Test, press ADVANCE. Observe that the Player 1 and 2 displays show the message, ALL LAMPS, and that the Player 3 display shows 03 (All Lamps Test identifier) and that all feature lamps (playfield and backbox) blink on and off. (Note, however, that the General Illumination lamps remain lighted steadily.) To locate the wiring associated with a particular feature lamp, refer to the Lamp-Matrix Table. CPU Board connections at jacks 1J6 (columns) and 1J7 (rows) are also listed in the table.

2. Single Lamps

From the All Lamps test, using AUTO-UP, press ADVANCE to initiate the Single Lamps Test. The Player 1 and 2 displays initially show the message, SINGLE LAMPS, and the Player 3 display shows 04. Then, the Player 3 display shows 04 01, and the Player 1 and 2 displays change to show "SHOOT AGAIN", the name of the lamp currently blinking. Press the Credit button to proceed through an ascending series of designator numbers (01 through 64), with the Player 1 and 2 displays showing the individual lamp's name. (To proceed through a descending series of lamp identifiers, use MANUAL-DOWN.) Press and hold the Credit button to proceed rapidly to the desired lamp.

GAME SHOW Lamp Matrix

column	1 Q66 YEL-BRN 1J7-1	2 Q64 YEL-RED 1J7-2	3 Q62 YEL-ORN 1J7-3	4 Q60 YEL-BLK 1J7-4	5 Q58 YEL-GRN 1J7-6	6 Q56 YEL-BLU 1J7-7	7 Q54 YEL-VIO 1J7-8	8 Q52 YEL-GRY 1J7-9
1 Q80 RED-BRN 1J6-1	Shoot Again 1	Bonus 1K 9	Wheel 5K 17	Wheel 45K 25	TRUCK Letter-T 33	Big Bucks 41	2 Million Left 49	Top Lane Right 57
2 Q81 RED-BLK 1J6-2	Wheel 5X 2	Bonus 2K 10	Wheel 10K 18	Wheel 50K 26	TRUCK Letter-R 34	Top Lane Red 42	Left Spot Letter 50	Grand Prize 58
3 Q82 RED-ORN 1J6-3	Bonus Multiplier 1X 3	Bonus 4K 11	Wheel 15K 19	TV Letter-T 27	TRUCK Letter-U 35	Top Lane Red 43	Left Extra Ball 51	Collect TV 59
4 Q83 RED-YEL 1J6-5	Bonus Multiplier 2X 4	Bonus 8K 12	Wheel 20K 20	TV Letter-V 28	TRUCK Letter-C 36	Back Panel Car 44	2 Million Right 52	Collect Trip 60
5 Q84 RED-GRN 1J6-6	Bonus Multiplier 4X 5	Bonus 16K 13	Wheel 25K 21	TRIP Letter-T 29	TRUCK Letter-K 37	Left Extra Ball 45	Right Spot Letter 53	Collect Truck 61
6 Q85 RED-BLU 1J6-7	Bonus Multiplier 8X 6	Bonus 32K 14	Wheel 30K 22	TRIP Letter-R 30	Wheel 250,000 38	Wheel 4 Million 46	Right Spinner 54	Collect Car 62
7 Q86 RED-VIO 1J6-8	Center Spinner 7	Bonus 64K 15	Wheel 35K 23	TRIP Letter-I 31	Wheel Hold Bonus 39	Wheel Extra Ball 47	Top Lane Left 55	Collect Prizes 63
8 Q87 RED-GRY 1J6-9	Center Nudge 8	Bonus 128K 16	Wheel 40K 24	TRIP Letter-P 32	Wheel 1 Million 40	Right Extra Ball 48	Top Lane Middle 58	Right Lock 64

SOLENOID TEST

- (From Lamp Test) Using AUTO-UP, press ADVANCE. Observe that the Player 1 and 2 displays show the message, COIL TEST, the Player 3 display shows 05 (Solenoid Test identifier). Next, the Player 3 display shows a series of test steps from 01 through 22, while the Player 1 and 2 displays show the solenoid/circuit name. During each of these steps, pulsing of the respective solenoid/circuit occurs. The test cycles repeatedly, unless halted via the MANUAL-DOWN switch. Refer to the Solenoid Table for solenoid numbers and wiring information. CPU Board connections at 1P11, 1P12, and 1P19 are also listed in the table.

To continuously pulse a single solenoid/circuit, use MANUAL-DOWN. Press ADVANCE to sequence through the switched, controlled, and special solenoids. Use AUTO-UP to resume test cycling, and to proceed to the next test.

GAME SHOW

Solenoid Table

Sol. No.	Function	Solenoid Type	Wire 1 Color	Connections		Driver Trnstr	Solenoid Part Number	
				CPU Bd	Playfield/Cabinet		Flashlamp Type	
01A	Outhole Kicker	Switched	Vio-Brn }	1P11-1	5J1-9: 5J4-9 (A)	Q33	AE-23-800	
01B	Top Cntr Lvl/ Insert Teeth Flasher	Switched	Blk-Brn }	(Gry-Brn)	5J5-9 (C)	Q33	#89 Flashlamps	1b/1p
02A	Ball Shooter Ln Feeder	Switched	Vio-Red }	1P11-3	5J1-7: 5J4-8 (A)	Q25	AE-23-800	
02B	Rt Back Pnl/Insert 3 Mil Flasher	Switched	Blk-Red }	(Gry-Red)	5J5-8 (C)	Q25	#89 Flashlamps	1b/1p
03A	Not Used	Switched	Vio-Orn }	1P11-4	5J1-6: 5J4-7 (A)	Q32	Not Used	
03C	Left Plyfld/Insert Title Flasher	Switched	Blk-Orn }	(Gry-Orn)	5J5-7(C)	Q32	#89 Flashlamps	1b/1p
04A	Not Used	Switched	Vio-Yel }	1P11-5	5J1-5: 5J4-6 (A)	Q24	Not Used	
04C	Rt Plyfld/Insert Title Flasher	Switched	Blk-Yel }	(Gry-Yel)	5J5-5 (C)	Q24	#89 Flashlamps	1b/1p
05A	Ball Locker	Switched	Vio-Gm }	1P11-6	5J1-4: 5J4-5 (A)	Q31	AE-23-800	
05C	Upper Left Flasher	Switched	Blk-Gm }	(Gry-Gm)	5J5-4 (C)	Q31	#89 Flashlamp	1p
06A	Not Used	Switched	Vio-Blu }	1P11-7	5J1-3: 5J4-4 (A)	Q23	Not Used	
06C	Rt Back Pnl/Insert Wheel Flasher	Switched	Blk-Blu }	(Gry-Blu)	5J5-3 (C)	Q23	#89 Flashlamps	1b/1p
07A	Knocker	Switched	Vio-Blk }	1P11-8	5J1-2: 5J4-2 (A)	Q30	AE-23-800	
07C	Applause Flasher	Switched	Blk-Vio }	(Gry-Vio)	5J5-2 (C)	Q30	#906 Flashlamps	2b
08A	Car Drop Target	Switched	Vio-Gry }	1P11-9	5J1-1: 5J4-1 (A)	Q22	AE-23-800	
08C	Applause Flasher	Switched	Blk-Gry }	(Gry-Blk)	5J5-1 (C)	Q22	#906 Flashlamps	2b
9	Plyfld G.I. Relay	Controlled	Brn-Blk	1P12-1	5J2-9: 5J6-9: 2J4-3	Q17	5580-09555-01	4a
10	Top Ramp Gate	Controlled	Brn-Red	1P12-2	5J2-8: 5J6-8: 2J4-5	Q9	SM2-35-4000	
11	Center Ramp Flasher	Controlled	Brn-Orn	1P12-4	5J2-6: 5J6-7:	Q16	#89 Flashlamp	1p
12	A/C Select Relay	Controlled	Brn-Yel	1P12-5	2J4-6	Q8	5580-09555-01	5
13	Bell	Controlled	Brn-Gm	1P12-6	5J2-5	Q15	SM-26-600	
14	Ball Popper	Controlled	Brn-Blu	1P12-7	5J2-4: 5J6-5	Q7	AE-23-800	
15	Backbox G.I. Relay	Controlled	Brn-Vio	1P12-8	5J2-4: 5J6-3	Q14	5580-09555-01	4a
16	Insert Teeth/Title Flasher	Controlled	Brn-Gry	1P12-9	5J2-2: 5J6-2	Q6	#89 Flashlamps	4b
17	Left Jet Bumper	Special #1	Blu-Brn	1P19-7	5J2-1: 5J6-1	Q75	AE-23-800	
18	Left Kicker	Special #2	Blu-Red	1P19-4	5J3-7: 5J7-7	Q71	AE-26-1500	
19	Right Jet Bumper	Special #3	Blu-Orn	1P19-3	5J3-6: 5J7-6	Q73	AE-23-800	
20	Right Kicker	Special #4	Blu-Yel	1P19-6	5J3-3: 5J7-3	Q69	AE-23-1500	
21	Bottom Jet Bumper	Special #5	Blu-Gm	1P19-8	5J3-4: 5J7-5	Q77	AE-23-800	
22	Not Used	Special #6	Blu-Blk	1P19-9	5J3-2: 5J7-2	Q79	Not Used	
-	<u>Right Flipper</u>	-	Orn-Vio ²	1P19-1	2J5-5: 2J10-7	-	-	-
-	Lower Right Flipper	-	[Blu-Vio]	-	[2J10-1: 2J8-15]	-	FL11630/ 50VDC	-
-	<u>Left Flipper</u>	-	Orn-Gry ²	1P19-2	2J5-4: 2J10-8	-	-	-
-	Lower Left Flipper	-	[Blu-Gry]	-	[2J10-2: 2J8-4]	-	FL11630/ 50VDC	-

Notes 1. Wire colors, except flipper Orn- Vio and Orn-Gry are ground connections (to terminal with unbanded end of diode). Flipper Orn-Vio and Orn-Gry wires connect from CPU Board to flipper switch. 2. Flipper connections shown in braces are from flipper switch to flipper coil. 3. "A" circuits are pulsed, when Sol. 12 is de-energized; "C" circuits are pulsed, with Sol. 12 energized. Wire colors in brackets are those from respective A and C terminals corresponding to the J1-terminal connection listed for the Aux Power Driver Bd. which controls the device pulsing by Sol. 12. 4. Relay is mounted on Relay bd. (4a) C-11998-1; (4b) C-11902-1. 5. Relay mounted on Aux. Power Driver Bd., D-12247.

"On" State Logic - Special Solenoid

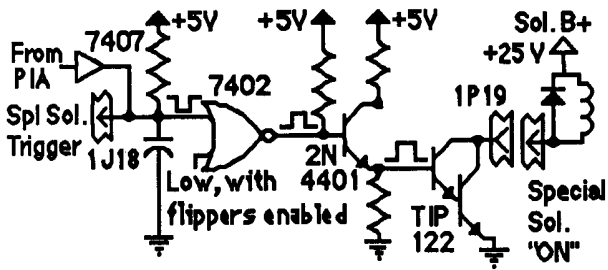

"On" State Logic - Controlled

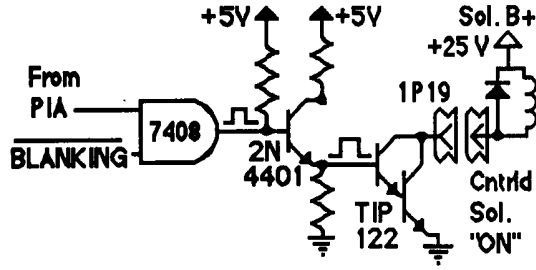

"Off" State - Special Solenoid:

The Special Switch Trigger Input goes low. Meanwhile, the PIA line remains high. The remaining signals reverse their states.

"Off" State - Controlled Solenoid:

The Enable Input (from the PIA) goes low. Meanwhile, the BLANKING signal remains high. The rest of the signals reverse their states.

NOTE

As directed by the game program, the Solenoid A/C Select Relay (solenoid 12) switches the solenoid B+ power between two power busses to permit actuating two groups of solenoids at the proper times. In its de-energized state, the Relay connects the 'circuit A power' to 16 "controlled" and "switched" solenoids (identified in the table with no suffix letter or the letter A, after the solenoid number). Individual solenoid operation then depends on the game program enabling the ground path for solenoid actuation via the driver transistor associated with each solenoid circuit. For example, the game program can actuate the Outhole Kicker solenoid (sol. 01A), via the driver transistor Q33.

When the game program determines that the Solenoid A/C Select Relay (sol. 12) must be energized, the relay connects 'circuit C power' to eight group C solenoids (01C through 08C). Now, driver transistor Q33 can actuate the Flasher circuit (sol. 01C), which has two lamp circuits. Using this "multiplexing" technique, the same driver transistor can control actuation of two separate solenoid circuits.

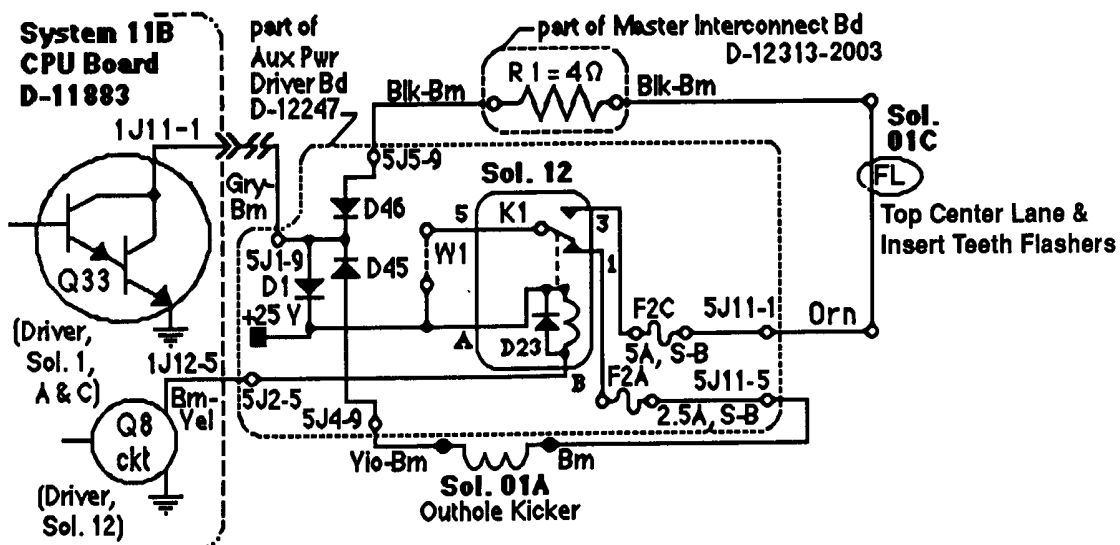

Figure 4. Typical Solenoid A/C Select Relay Circuit, showing the function of Solenoid 12, the Solenoid A/C Select Relay

SWITCH TESTS

1. Switch Levels

(From Solenoid Test) To initiate the Switch Levels Test, press ADVANCE. Observe that the Player 1 and 2 displays show the message, SWITCH LEVELS, and the Player 3 display shows 06 (Switch Levels Test identifier). Normally, the right portion of the Player 3 display remains blank, indicating that no switch is actuated.

If, however, a switch is actuated (possibly stuck closed), the Player 3 display shows that switch's number, while the Player 1 and 2 displays indicate the switch's name. A sound also accompanies the displays. (This is another facet of the *GAME SHOW* System-11B's switch testing capability.) If more than one switch is closed, a series of displays show each actuated switch's name and number.

(In addition, either of these problems could result in the reporting of a switch problem (or problems) at game Turn-On or at the beginning of Diagnostic Tests.)

As soon as the operator opens a closed switch, its name and number are eliminated from the Switch Levels display series. For *GAME SHOW*, switch numbers can range from 01 through 64. Refer to the Switch-Matrix Table for switch numbers and wiring information. CPU Board connections at jacks 1J8 (columns) and 1J10 (rows) are also listed in the table.

GAME SHOW Switch Matrix

column	1 Q45	2 Q49	3 Q44	4 Q48	5 Q43	6 Q47	7 Q42	8 Q46
	GRN-BRN	GRN-RED	GRN-ORN	GRN-YEL	GRN-BLK	GRN-BLU	GRN-VIO	GRN-GRY
ROW	1J8-1	1J8-2	1J8-3	1J8-4	1J8-5	1J8-7	1J8-8	1J8-9
1 WHT-BRN 1J10-9	Plumb Bob Tilt 1	Not Used 9	Top Lane, Left 17	Easy Spin 25	Prize Letter T in TRUCK 33	Spin Wheel 41	Not Used 49	Right Flipper 57
2 WHT-RED 1J10-8	Not Used 2	Outhole 10	Top Lane, Middle 18	Center Ramp 26	Prize Letter R in TRUCK 34	Right Spinner 42	Not Used 50	Left Flipper 58
3 WHT-ORN 1J10-7	Credit Button 3	Trough 1, Right 11	Top Lane, Right 19	Prize Letter T in TV 27	Prize Letter U in TRUCK 35	Spot Letter 43	Not Used 51	Not Used 59
4 WHT-YEL 1J10-6	Right Coin 4	Trough 2, Left 12	Right Ramp 20	Prize Letter V in TV 28	Prize Letter C in TRUCK 36	Not Used 44	Not Used 52	Left Jet 60
5 WHT-GRN 1J10-5	Center Coin 5	Not Used 13	Ball Popper 21	Prize Letter T in TRIP 29	Prize Letter K in TRUCK 37	Left Outlane 45	Not Used 53	Right Jet 61
6 WHT-BLU 1J10-3	Left Coin 6	Shooter Lane 14	Not Used 22	Prize Letter R in TRIP 30	Not Used 38	Left Return 46	Not Used 54	Bottom Jet 62
7 WHT-VIO 1J10-2	Start Tilt 7	Not Used 15	Left Lockup 23	Prize Letter I in TRIP 31	Drop Target Car 39	Right Return 47	Not Used 55	Left Slingshot 63
8 WHT-GRY 1J10-1	High Score Reset 8	Big Bucks 16	Not Used 24	Prize Letter P in TRIP 32	Not Used 40	Right Outlane 48	Not Used 56	Right Slingshot 64

- ▼ **Row Problems.** If a display of two (or more) switch numbers of a row occurs, although only one switch is closed, check for a short circuit to ground.
- ▼ **Multiple Switch Number Indications.** Check for a bad diode on any of the switches.
- ▼ **Column Problems.** If display of two (or more) switch numbers in a column occurs (while only one switch is actuated), check for a short circuit to ground or, a bad transistor (Q42-Q49) on the CPU Board.

Use AUTO-UP to proceed to the next test.

2. **Switch Edges**

From the Switch Levels Test, press ADVANCE. Observe that the Player 1 and 2 displays show the message, SWITCH EDGES; the Player 3 display shows 07 (Switch Edges Test identifier). The right portion of the Player 3 display is blank, indicating that no switch is actuated.

This test permits the operator to test whether actuating a switch provides the proper signal to the System-11B switch testing program. When actuating a switch, the operator should see the switch's name and number (in the Player 1, 2, and 3 displays, respectively). If no indication appears at the time the switch is actuated, the operator then knows that there is a malfunction associated with that switch. Using this technique, the operator can test each switch appearing in the *GAME SHOW* switch problem reporting displays (either at game Turn-On or at the beginning of the Diagnostic Tests) to determine whether the switch can be actuated. If the switch's name and number are displayed while the operator checks its operation, the operator then knows that the reported problem with that switch is NOT currently caused by a switch malfunction. The operator can then seek other causes for the reported problem, being almost certain now that the switch did not fail. This test is also useful when the operator is adjusting the sensitivity of a particular switch's actuation mechanism.

Among the possibilities is the fact that the players have not actuated that switch because of some other problem; the operator should try to analyze what could cause the switch to be missed during game play, and remedy that problem cause. With these new tests, switch problems are, therefore, more easily isolated.

3. **Playfield or CPU Board?** To determine whether a switch problem is in the playfield or the CPU Board, remove connectors 1P8 and 1P10 from the CPU Board. Begin the Switch Test. Use a jumper wire to simulate switch actuation. For example, placing a jumper between 1J10-9 and 1J8-2 should (based on the Switch-Matrix Table) should produce an indication of switch 09 being actuated. If only one number is produced for every simulated switch actuation that occurred then the CPU is good and the problem is elsewhere.

C-SIDE TEST

From the Switch Test, press ADVANCE. Observe that the Player 1 and 2 displays show the message, C-SIDE TEST, and that the Player 3 displays shows 09 (C-Side Test identifier). This test confirms that the Solenoid A/C Select Relay (Sol. 12) is actually in the 'C' position (ready to power flashlamp circuits).

The Player 1 and 2 displays then change to show the 'side' of the circuit being tested, alternating the A/C Relay between "SELECTED A-SIDE" and "SELECTED C-SIDE", while the Player 4 display shows the state of the C-Side Switch. When the switch is closed, the Player 4 display shows "C-SIDE".

The message "Err" appears whenever the C-Side Switch is not operating properly. Causes of improper operation can be blown fuses (F8 or F2C) or a faulty relay on the Aux Power Driver Board; failure of the 12 or 24 volt power circuits; a switch matrix failure; or faulty connections between the circuit boards in the game's backbox (CPU Board, Aux Power Driver Board, Backbox Interconnect Board). To halt the A/C Relay's operation, press MANUAL-DOWN and press ADVANCE to activate the A/C Relay manually.

ENDING THE DIAGNOSTIC TESTS

To end the Diagnostic Tests, reach the C-Side Test use AUTO-UP and press ADVANCE. The backbox displays should MANUAL-DOWN, and press ADVANCE to reach Adjustment Item 70 (INSTALL FACTORY). Use AUTO-UP, and press ADVANCE to go to the Attract Mode.

AUTO BURN-IN MODE

The Auto Burn-in Mode permits the operator to check intermittent (or nonrecurring) problems associated with most portions of the game's circuitry. Repeatedly cycling through a group of tests can sometimes bring a problem, which occurs only randomly or occasionally, to exhibit itself more frequently, thereby aiding in the isolation of the problem. To activate the Auto Burn-in Mode:

1. While in the Game Adjustments, reach Ad 67 and change the Factory Setting of NO to YES, via the Credit button. Set the AUTO-UP/MANUAL-DOWN switch to AUTO-UP.
2. Press ADVANCE to start the Auto Burn-in Mode. This mode repeatedly sequences through the Music Test, the Display Test, the All Lamps portion of the Lamp Test, and the Solenoid Test.
3. To halt the Auto Burn-in Mode, switch the game Off and then On. *GAME SHOW* now starts in the Attract Mode. (If a switch problem is now reported by the displays, perform the Switch Tests again to determine the nature of the problem; then, perform necessary repairs.)

CPU LED Indicator Codes Table

Blinks/ Flashes	CPU Problem	Explanation
1	U25 RAM FAILURE	U25 RAM could not be used properly (NO other tests are performed; the game is locked here, until the game is turned off).
2	MEM. PROT. FAILURE	This message means that (A) the Coin Door may be shut; (B) the Memory Protect Switch may be stuck in the ON position; (C) the memory protect logic is protecting the memory; or (D) a U25 RAM failure is occurring. (See Note 1)
3	U51 PIA FAILURE	U51 has a malfunction. (See Note 2)
4	U38 PIA FAILURE	U38 has a malfunction. (See Note 2)
5	U41 PIA FAILURE	U41 has a malfunction. (See Note 2)
6	U42 PIA FAILURE	U42 has a malfunction. (See Note 2)
7	U54 PIA FAILURE	U54 has a malfunction. (See Note 2)
8	U10 PIA FAILURE	U10 has a malfunction. (See Note 2)
9	IRQ FAILURE	IRQ has a malfunction. It may be missing or too fast or too slow.
1 0	U27 ROM FAILURE	U27's internal checksums do not match. It may be a ROM failure, or its associated connections and connecting devices are causing it to appear to have a problem. (The following U26 test is skipped.)
1 1	U26 ROM FAILURE	U26's internal checksums do not match.
Notes: 1. This test assumes that the Coin Door is OPEN; it is initiated ONLY by pressing the CPU Diagnostic Switch (SW2). 2. Alternatively, its associated connections or connecting devices are causing the IC to appear to have problems.		

SYSTEM-11B MEMORY CHIP TEST

A new feature is now included in the Memory Chip Test for System 11B. During power-up, the CPU performs a self-testing routine. When all tests are satisfactory, the game proceeds to the Attract Mode, allowing players to use the game. Whenever a portion of the testing does not produce satisfactory results, the game displays a message, before proceeding to the next portion of the testing. ONLY after all tests are satisfactory does the game allow play to begin.

In addition to the displayed message, when a test fails, LED 2 ('DIAGNOSTIC') mounted on the CPU Board can be observed to determine the probable cause of the problem. This LED blinks, or flashes, a certain number of times to identify the probable cause, as described in the CPU LED Indicator Codes Table. The operator can also reset the program by pressing the CPU Switch (SW 2) on the edge of the CPU Board.

SYSTEM-11B SOUND CIRCUITRY TESTS

Tests of the System-11B Sound circuitry, including the Audio Board, are possible only after successful completion of the System-11B Memory Chip Test.

1. **Audio Board Test.** A brief check of the Audio Board (D-11581) circuitry occurs at game Turn-on; the game reports the test results by brief sounds, as follows: No sound = Audio Board is not operating, or a failure is affecting the sound circuitry (broken cable; dead amplifier; etc.); 1 sound = system OK; 2 sounds = RAM problem; 3 sounds = U4 problem; 4 sounds = U19 problem.

If the this test did not isolate the problem, turn the Volume Control for maximum output. Momentarily touch a powered-up AC soldering iron on the center tap of the Volume Control.

CAUTION

DO NOT use a soldering iron over 40 watts. Note also that cordless soldering irons will NOT work for this test.

Hearing a low hum or a 'click' indicates that the power amplifier (U1, TDA2002), the Volume Control, and the speaker are operating satisfactorily, as is the sound circuit cabling. Not hearing a sound requires repeating the test with the Volume Control turned part way down, to determine whether the Volume Control is faulty. Also, check the cable connectors for proper mating, and that no broken wires affect this circuit.

Problem Analysis Messages

The SYSTEM 11B game program has a great capability to aid the operator and service personnel: At game Turn-on (and also at the beginning of Test/Diagnostic Procedures) after the game has been operating for an extended period, the player score displays now may signal with a message, "Press ADVANCE for Report", that the game program has detected a possible problem with the game.

To obtain details of the problem, open the coin door and press the AUTO-UP/MANUAL-DOWN switch to MANUAL-DOWN. Press the ADVANCE button to begin displaying the message(s). The following messages apply to *GAME SHOW*.

Malfunction Check Switch ## (name). This message indicates that at least one switch has not been actuated during ball play (for 90 balls or apx. 30 games) by displaying the message "Check Switch ## (name)", listing each problem switch by number and name. (The game program compensates the game play requirements affected by each disabled switch to allow 'nearly normal' play. This helps keep *GAME SHOW* earning good profits).

To verify the problem, refer to the Test/Diagnostic Procedures text describing Switch Testing, and check each reported switch using applicable Switch Levels and Switch Edges tests. Always check switch operation using a ball to simulate game conditions. (Switch problems may often be resolved by adjusting the wire switch actuators, fixing electric problems, securing loose connectors, etc).

Malfunction Pinball Missing. *GAME SHOW* normally uses two balls. This message announces that one is missing or stuck somewhere. When the ball is located, return it to the playfield via the Outhole. Other possibilities for this problem could be malfunctions of the Ball Trough Switches (#11, or #12) or, the Ball Shooter Switch (#14).

Music Error. This message means that no signals are coming from the Audio Board. Check the Audio Board for presence of *GAME SHOW* ROMs. Also, check that the cable connecting the Audio and CPU Boards is firmly seated, and that the red line on the cable is going to the same pin on both boards. Turn the game Off, then On, to be sure only 1 'Bing' sounds. More than one 'Bing' or, *no* 'Bing' indicates an Audio Board problem. Refer to text about System 11B Sound Circuitry tests for more information.

Maintenance Information

• Ball Shooter Lane Feeder

Figure 5 shows the two main lubrication points of the Ball Shooter Lane Feeder. The shaded arrows show the directions in which the Ball Shooter Lane Feeder and other parts of its related assemblies can be adjusted for proper operation. Note that there are mechanisms quite similar to this Assembly; they have the same lubrication requirements and adjustment capabilities as the Ball Shooter Lane Feeder.

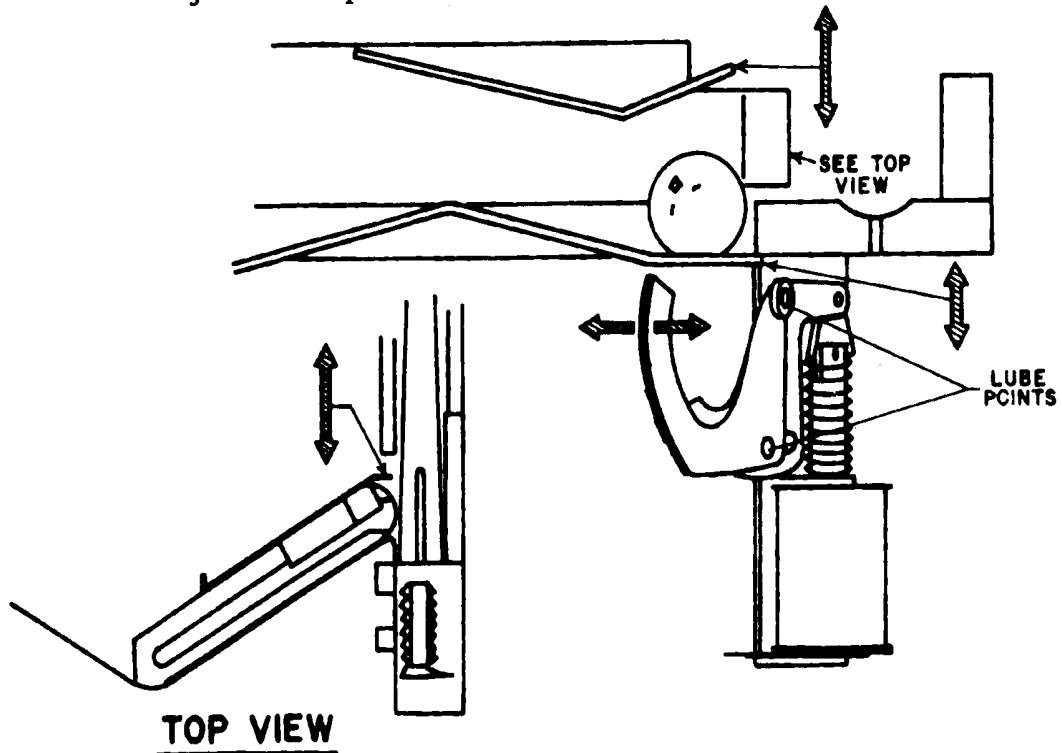

Figure 5. Adjustments and Lubrication Points, Shooter Lane Feeder

• Left & Right Kickers

Because of the functional design (arm-actuated via solenoid plunger operation), the pivot points of the Left and Right Kickers ("Slingshots") all require lubrication as a regular servicing procedure. Mechanical adjustments are simple and somewhat similar to the Ball Shooter Lane Feeder. These mechanisms should also be checked for proper fit (snugly tight) where they attach to the playfield.

- **Playfield**

Playfield life expectancy and play can be extended by periodic cleaning. Inspect and hand polish the balls in a clean cloth. Replace chipped balls; otherwise, these balls will ruin the playfield finish in a short time. Don't use quantities of water, caustic or abrasive cleaners or cleaning pads on the playfield. Don't allow polish or wax to build-up, (waxes yellow with age and spoil the appearance of the playfield).

- **Switches**

Switch contacts should be free of dust, dirt, and corrosion. Filing or burnishing most switch contacts breaks the finish and encourages corrosion. Effective contact cleaning requires gentler treatment. Gently close the contacts on a clean business card or piece of paper. Wipe the contacts until they're clean. If necessary, regap the contacts to 1/16 inch.

Flipper End-of-Stroke switch contacts must be treated differently from other switch blade contacts; they provide heavier current carrying capability than other pinball game switch contacts. Severely pitted contacts cause flippers to be weak. Smooth the pitted contact surface of the E.O.S. switch contacts with a contact file. Then, polish your work with a burnishing tool. regap the contacts if necessary, to 1/16 inch.

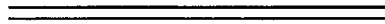

Fuse Locations Diagram & Listing

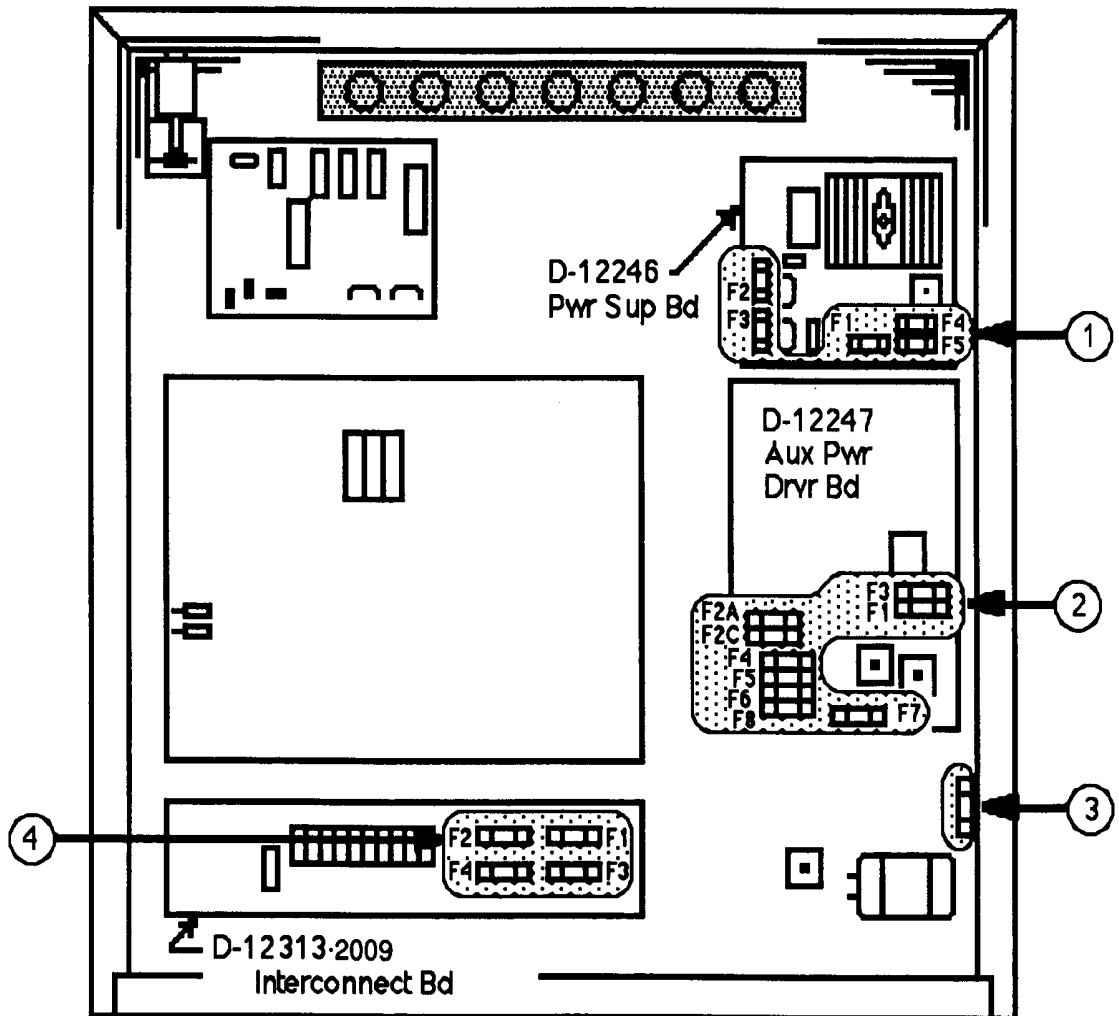

Fuse Listing

ITEM	PART NUMBER	DESCRIPTION	CIRCUIT/LOCATION
1	5731-12328-00	Fuse, 3/8A., S-B, 250V	F1; D-12246 Power Supply Board
1	5731-12327-00	Fuse, 1/8A., S-B, 250V	F2, F3; D-12246 Power Supply Board
1	5731-09432-00	Fuse, 7A S-B, 250v	F4, F5; D-12246 Power Supply Board
2	5731-09128-00	Fuse, 2-1/2A., S-B, 250v	F1, F2A, F3, F4; D-12247 Aux Pwr Driver Board
2	5731-09651-00	Fuse, 5A., S-B, 250v	F2C; D-12247 Aux Pwr Driver Board
2	5731-08665-00	Fuse, 2A., S-B, 250v	F5, F6; D-12247 Aux Pwr Driver Board
2	5731-06314-00	Fuse, 4A., S-B, 250v	F7; D-12247 Aux Pwr Driver Board
2	5731-09432-00	Fuse, 7A., S-B, 250v	F8; D-12247 Aux Pwr Driver Board
3	5730-09071-00	Fuse, 8A., S-B, 32v	+18 Vdc Lamp Ckt/ Lwr Rt B/box fuseholder (1)
4	5731-09651-00	Fuse, 5A., S-B, 250v	F1 - F4; Gen. Illum./B'box Interconnect Board
-	5730-09252-00	Fuse, 8A,Slow-Blow(S-B),125v	Input ("high voltage") Power Line/Cabinet Box*

* One 4A., S-B, 250v fuse (5731-06314-00) is provided for an overseas (220v) game installation.

NOTES

S
E
C
T
I
O
N

2

Game Parts Information

CABINET PARTS

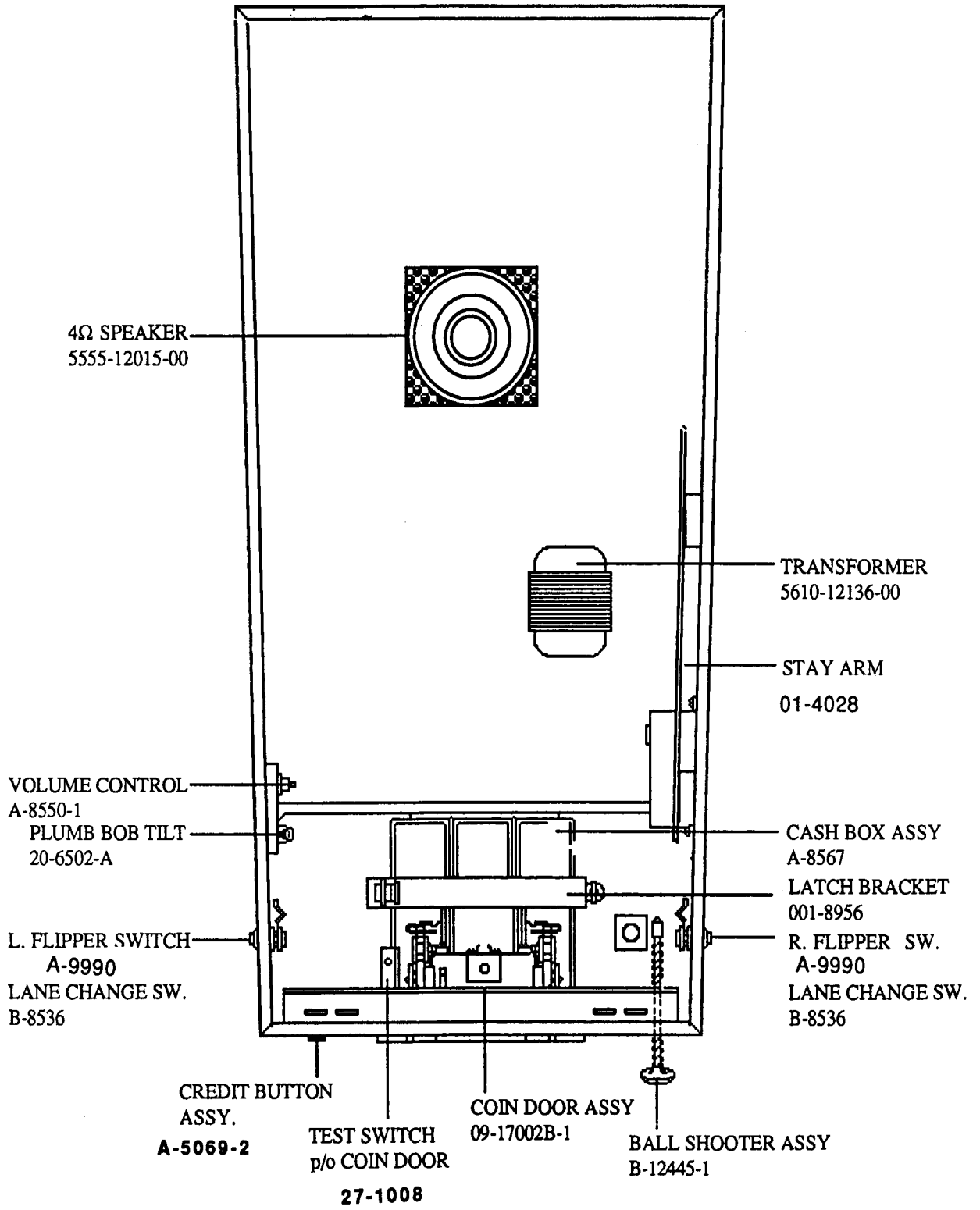

CIRCUIT BOARD & MAJOR MECHANISMS LOCATION DIAGRAM

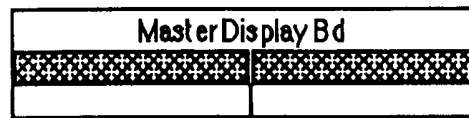
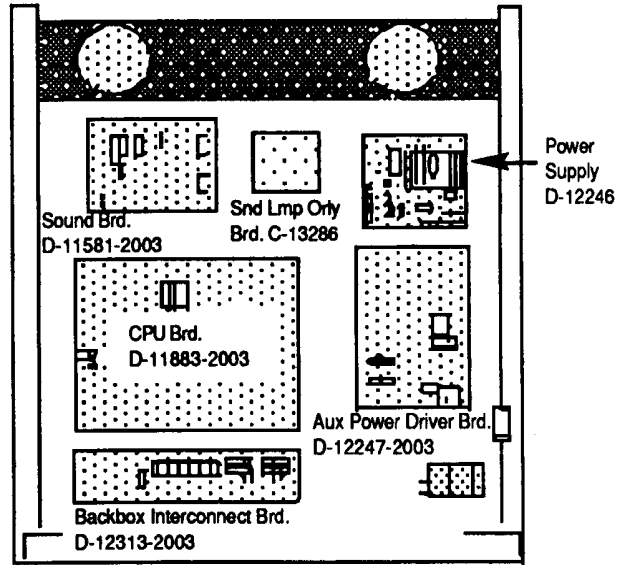
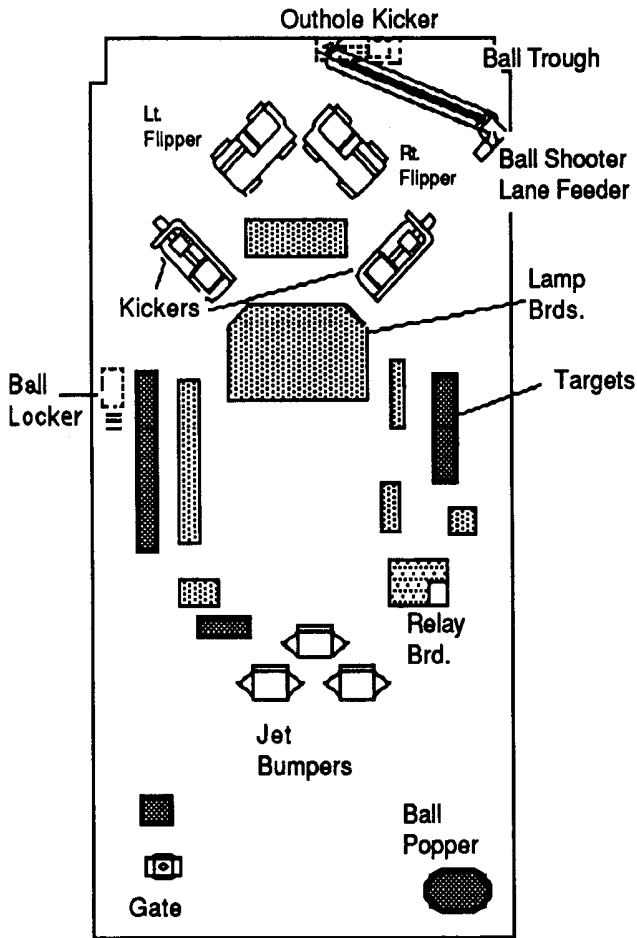

Display Panel, Rear View

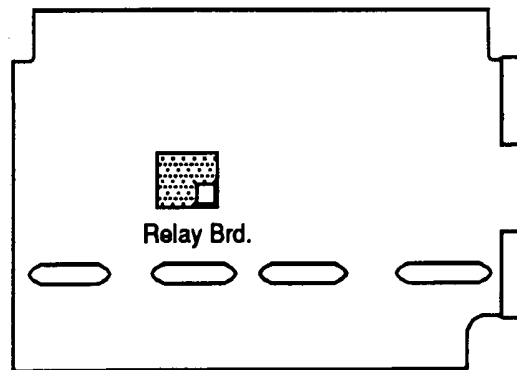
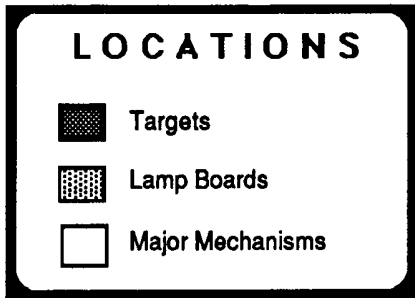

Insert Board, Inner Side View

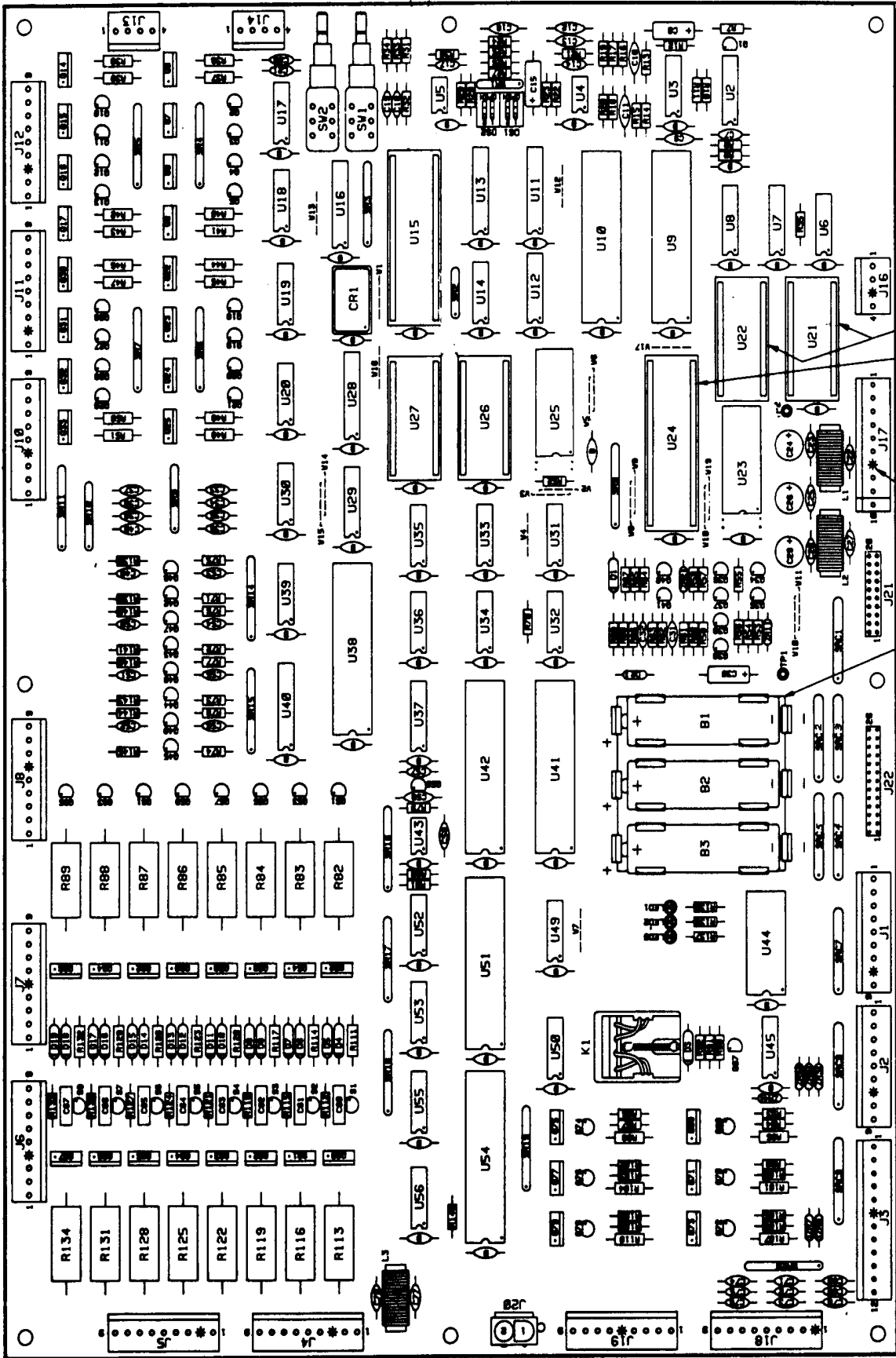

SYSTEM 11B CPU BOARD (D-11883)

System 11B CPU Board

p/n D-11883-2003

Item	Part No.	Ckt Designator	Description	Item	Part No.	Ckt Designator	Description
1	5764-12206-00		Bare P. C. Board	62	5010-10003-00	R62, R63	Resistor, 390Ω, 5%, 1/4w, C. F.
2	5370-09691-00	U3	IC, CVSD Mod., 55536	63	5010-10171-00	R67	Resistor, 56Ω, 5%, 1/4w, C. F.
3	5370-09321-00	U4, U5	IC, Dual Op Amp, 1458	64	5010-10170-00	R69	Resistor, 47Ω, 5%, 1/4w, C. F.
4	5281-09308-00	U16	IC, Octal Bus Xcvr, 74LS245	65	5010-09160-00	R59, R61, W12, W13	Resistor, 220Ω, 5%, 1/4w, C. F.
5	5430-08972-00	U9, U10, U38, U41, U42, U51, U54	IC, PIA, MC6820/6821	66	5010-09416-00	R33, R34, R71-R78, R135-R137	Resistor, 470Ω, 5%, 1/4w, C. F.
6	5340-10139-00	U25	IC, 2K x 8 CMOS Static RAM	67	5010-09179-00	R9	Resistor, 3.3MΩ, 5%, 1/4w, C. F.
7	5280-09010-00	U44	IC, 4-16 Decoder, 74154	68	Not Used		
8	5281-09248-00	U7, U8, U12	IC, 2-4 Decoder, 74LS139	69	5010-10631-00	R111, R114, R117, R120, R123, R126, R129, R13	Resistor, 1.2KΩ, 5%, 1/2w, C. F.
9	5075-09406-00	ZR3 - ZR8	Diode, Zener, 6.2v, 0.5w	70	Not Used		
10	5164-10998-00	Q42 - Q49	Transistor, NPN, 2N5550, TO-92	71	Not Used		
11	5281-09487-00	U8	IC, Dual D Flip-flop, 74LS74	72	5010-09120-00	R17	Resistor, 270KΩ, 5%, 1/4w, C. F.
12	5431-09449-00	U43	IC, Timer, MC1455	73	5010-09333-00	R15, R16, R18	Resistor, 180KΩ, 5%, 1/4w, C. F.
13	5310-09236-00	U29	IC, 14-b Counter, 4020	74	5010-09324-00	R29, R30	Resistor, 27KΩ, 5%, 1/4w, C. F.
14	5281-09743-00	U32	IC, Quad 2-Input AND, 74LS08	75	5010-09269-00	R20, R21	Resistor, 12KΩ, 5%, 1/4w, C. F.
15	5281-09247-00	U14	IC, Quad 2-Input NOR, 74LS02	76	5010-09356-00	R27, R28	Resistor, 820Ω, 5%, 1/4w, C. F.
16	5281-09235-00	U35	IC, Triple 3-Input NAND, 74LS10	77	5019-09783-00	SR18	SIP, 9R, 10-pin, 2.7KΩ, .125w/R, 5%
17	5280-09013-00	U36	IC, Hex Inverter, 7404	78	5019-09362-00	SR3, SR15, SR17, SR19, SR20	SIP, 9R, 10-pin, 4.7KΩ, .125w/R, 5%
18	5281-09499-00	U31, U34	IC, Quad 2-Input NAND, 74LS00	79	5019-09808-00	SR4, SR6, SR11	SIP, 9R, 10-pin, 560Ω, .125w/R, 5%
19	5281-10014-00	U33	IC, Dual 4-Input NAND, 74LS20	80	5019-09785-00	SR16	SIP, 9R, 10-pin, 2.2KΩ, .125w/R, 5%
20	5281-09486-00	U28	IC, Octal D Flip-flop, 74LS374	81	5019-10472-00	SR14	SIP, 9R, 10-pin, 3.3KΩ, .125w/R, 5%
21	5371-09152-00	U2	IC, D/A Converter, MC1408	82	5019-09869-00	SR8	SIP, 9R, 10-pin, 1.0KΩ, .125w/R, 5%
22	5281-09745-00	U37	IC, 3-8 Decoder, 74LS138	83	5019-09780-00	SR9, SR10	SIP, 4R, 8-pin, 1KΩ, 5%
23	5340-09878-00	U23	IC, 2K x 8 Static RAM, 2016	84	5019-09786-00	SR1, SR2	SIP, 5R, 6-pin, 4.7KΩ, .125w/R, 5%
24	Not Used			85	5019-09792-00	SR5, SR7	SIP, 9R, 10-pin, 2.7KΩ, .125w/R, 5%
25	5281-09887-00	U11, U13, U40	IC, Octal Buffer, 74LS244	86	5080-10396-00	SRC1 - SRC5, SRC7 - SRC9	SIP, 8R, 8C, 10-pin, 4.7KΩ & 470pfd
26	5280-08973-00	U17-U20, U52, U53	IC, Quad 2-Input AND, 7408	87	5010-08774-00	R22	Resistor, 22KΩ, 5%, 1/4w, C. F.
27	5280-08974-00	U55, U58	IC, Hex Inverter, 7406	88	5043-09880-00	C14, C17-C21, C31, C32, C49-C56, C59, + 54 Bypass, marked B	Capacitor, 0.01 μfd, 50v(+80, -20%), Axial
28	5310-09155-00	U30, U39	IC, Quad 2-Input NAND, MC14011	89	5043-09845-00	C22, C23, C25, C27, C28	Capacitor, 1K pfd, 50v(±20%), Axial
29	5280-08948-00	U45, U50	IC, Quad 2-Input NOR, 7402	90	5043-08996-00	C9, C70-76, C77, C78	Capacitor, 0.1 μfd, 50v(±20%), Axial
30	5280-09309-00	U49	IC, Hex Buffer, 7407	91	5040-09343-00	C8, C15	Capacitor, 10 μfd, Electr., 20v(±20%), Axial
31	5671-09019-00	LED1-LED3	LED, Red, Display	92	5043-09844-00	C7	Capacitor, 47 pfd, 50v(±20%), Axial
32	5521-10506-00	CR1	Oscillator, 4 MHz	93	5040-10974-00	C24, C26, C29	Capacitor, 100 μfd, Electr., 25v(+50, -10%), Axial
33	5162-08976-00	Q51, Q53, Q55, Q57, Q59, Q61, Q63, Q65	Transistor, NPN Darl. 2N6427, TO-92	94	Not Used		
34	5191-08978-00	Q52, Q54, Q56, Q58, Q60, Q62, Q64, Q66	Transistor, PNP, TIP42, TO-220	95	5045-09796-00	C60-C67	Capacitor, 0.1 μfd, Polycarbonate Rad., 100v(±10%)
35	5162-09410-00	Q6-Q9, Q14-Q17, Q22-Q25, Q30-Q33, Q69, Q71, Q73, Q75, Q77, Q79, Q80-Q87	Transistor, NPN, TIP122, TO-220	96	5043-09065-00	C33-C40, C68, C69, C76, C10, C12	Capacitor, 470 pfd, 50v(±20%), Axial
36	5160-08938-00	Q2-Q5, Q10-Q13, Q18-Q21, Q26-Q29, Q34-Q38, Q41, Q67, Q68, Q70, Q72, Q74, Q76, Q78	Transistor, NPN, 2N4401, TO-92	97	5040-09545-00	C30	Capacitor, 22 μfd, Electr., 10v(+50, -10%), Axial
37	5180-10289-00	Q1, Q40	Transistor, NPN, 2N3904, TO-92	98	5041-09031-00	C58	Capacitor, 1 μfd, Tant., 25v(±20%), Axial
38	5190-09016-00	Q39, Q50	Transistor, PNP, 2N4403, TO-92	99	5043-09030-00	C16, C57	Capacitor, 0.047 μfd, 50v(±20%), Axial
39	5130-09014-00	S1-S8	SCR, 30v, 0.8A, 2N5060	100	Not Used		
40	5070-06258-00	D3-D19	Diode, 1N4001	101	5043-09492-00	C11	Capacitor, 100 pfd, ceramic, 100v(±20%)
41	5070-08919-00	D2	Diode, 1N4148, 150mA	102	Not Used		
42	5070-09286-00	D1	Diode, 1N5817, 1.0A	103	5048-10992-00	C13	Capacitor, 4700 pfd, ceramic, 50v(±10%)
43	5075-09018-00	ZR1	Diode, Zener, 1N5996A, 6.8v, 0.5w	104	5551-09822-00	L1-L3	Inductor, 4.7 μH, 3A
44	5075-09059-00	ZR2	Diode, Zener, 1N5990, 3.9v, 0.5w	105	5641-09312-00]	SW1, SW2	Switch, Pushbutton, DPDT, 100v, 5A
45	5010-08992-00	R94, R97, R100, R103, R106, R109	Resistor, 560Ω, 5%, 1/4w, C. F.	106	5880-09022-00	B1-B3	Battery, Alkaline, 1.5v, AA
46	5010-09039-00	R58	Resistor, 10Ω, 5%, 1/4w, C. F.	107	20-9491	W18, W19	Bus Wire, Jumper
47	5010-09534-00	W1, W2, W4, W5, W7, W8, W11, W14, W16, W17, W19	Resistor, 0Ω, 5%, 1/4w, C. F.	108	5881-09021-00		Battery Holder, #171
48	5010-08991-00	R31, R32, R35, R52	Resistor, 4.7KΩ, 5%, 1/4w, C. F.	109	5700-10176-00		IC Socket, 28 pin
49	5010-09358-00	R55, R68, R92, R146	Resistor, 1.0KΩ, 5%, 1/4w, C. F.	a)	A-5343-2003-1	U28	IC, Game ROM 2, 27256
50	5010-09113-00	R54, R57, R58, R64, R66, R138-R145	Resistor, 1.0KΩ, 5%, 1/4w, C. F.	b)	A-5343-2003-2	U27	IC, Game ROM 1, 27256
51	5010-08983-00	R79	Resistor, 33KΩ, 5%, 1/4w, C. F.	c)	A-5343-2003-3	U22	IC, Sound ROM 2, 27256
52	5010-09034-00	R7, R8, R10, R70, R80	Resistor, 3.3KΩ, 5%, 1/4w, C. F.	d)	A-5343-2003-4	U21	IC, Sound ROM 1, 27256
53	5010-09086-00	R11-R14, R25, R26, R53, R60, R65, R90	Resistor, 10KΩ, 5%, 1/4w, C. F.	110	5700-08985-00		IC Socket, 40 pin
54	5010-09363-00	R81	Resistor, 6.8KΩ, 5%, 1/4w, C. F.	a)	5400-09150-00	U15	IC, μProcessor, 6802
55	5010-08997-00	R3	Resistor, 5.6KΩ, 5%, 1/4w, C. F.	b)	5400-09150-00	U24	IC, μProcessor, 6802
56	5010-08997-00	R23, R24, R91, R93, R96, R99, R102, R105, R108, R112, R115, R118, R121, R124, R127, R130, R133	Resistor, 2.7KΩ, 5%, 1/4w, C. F.	111	5824-09248-00	TP1, TP2	Test Point
57	5010-08993-00	R113, R116, R119, R122, R125, R128, R131, R134	Resistor, 0.4Ω, 5%, 3w, Wire-Wnd.	112 - 115	Not Used		
58	5010-08993-00	R36-R51, R95, R98, R101, R104, R107, R110	Resistor, 68Ω, 5%, 1/2w, C. F.	116	20-9229		Thermal Compound
58	5012-08600-00	R82-R89	Resistor, 27Ω, 5%, 2w, C. F.	117	5580-08994-01	K1	Relay, 4-pole, 40Ω, 6v
59	Not Used			118	5791-10862-09	1J1, 1J2, 1J4-1J8, 1J10-1J12, 1J17-1J19	Connector, 9 pin (Hdr)
60	Not Used			119	5791-10862-04	1J13, 1J14, 1J16	Connector, 4 pin (Hdr)
61	5010-10987-00	R19	Resistor, 56KΩ, 5%, 1/4w, C. F.	120	5791-10862-12	1J3	Connector, 12 pin (Hdr)
				121	Not Used		
				122	5791-10850-00	1J22	Connector, 26 pin Ribbon (Hdr)
				123	5791-09437-00	1J21	Connector, 20 pin Ribbon (Hdr)

NOTES:

- For Schematic, refer to drawing #16-9019.
- Items 56 and 58 (resistors) must be mounted 1/8" above PCB surface.
- Standard Jumper: W1, W2, W4, W5, W7, W8, W11, W14, W16, W17, W19.

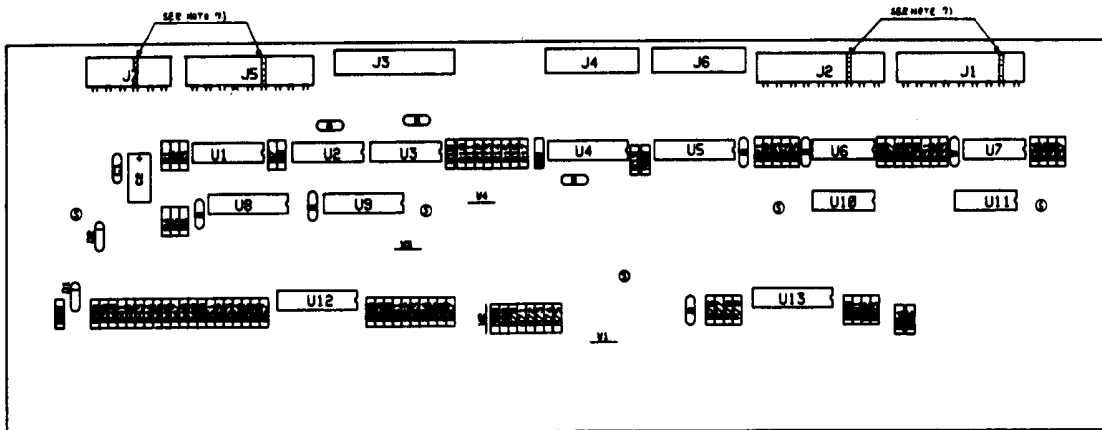

Bally Right Display Board D-12502-1

DESCRIPTION	QTY.	DESIGNATION NO.	PART NUMBER
Axial Cap., 0.01Mfd, 50v, +80, -20%	9	B (Bypass Cap)	5043-08980-00
Axial Cap., 0.1Mfd, 50v, +80, -20%	1	C1	5043-08996-00
Axial Cap., 10Mfd, 25v, ±20%	1	C2	5040-09343-00
Zener, 1N4740, 10v	2	D1, D2	5075-09135-00
Display, 16-Character A/N	1	DSPL1	5670-12308-00
9-Pin Header, Right Angle, .156	3	J1, J2, J5	5791-10869-09
26-Pin Header, Right Angle, .100	1	J3	5791-10851-00
6-Pin Header, Right Angle, .156	1	J7	5791-10869-06
Resistor, 18K 1/4w, 5%	25	R1-R8, R21-R37	5010-08773-00
Resistor, 100K 1/4w, 5%	32	R38, R40, R42, R44, R46, R48, R50, R52, R54- R61, R63, R65, R67, R69, R71, R73, R75-R83, R85	5010-09162-00
Resistor, 1M 1/4w, 5%	1	R86	5010-10258-00
Resistor, 8.2K 1/2w, 5%	7	R45, R49, R51, R62, R64, R68, R74	5010-10927-00
Resistor, 0	2	W3, W4	5010-09534-00
I.C. 4049	3	U1-U3	5310-08975-00
I.C. 4001	4	U6, U7, U10, U11	5310-09882-00
I.C. 7180, Cathode Driver	2	U8, U9	5680-08969-00
I.C. 6118, Anode Driver	2	U12, U13	5680, 08968-00
Bally-Lo-Display PCB	1		5768-12378-00
Support Display	5	S (Support)	03-8088-1
Assembly, I.D. Label	1		16-8850-251

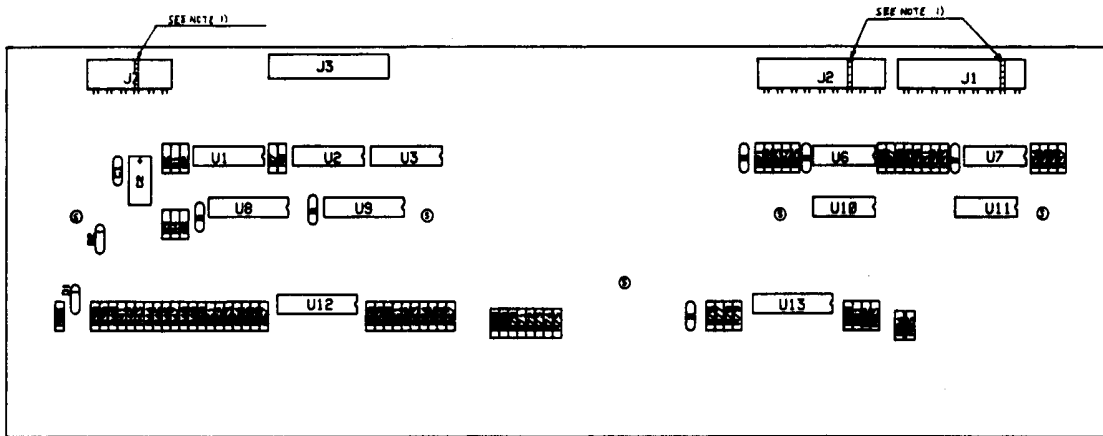

Bally Left Display Board D-12706

DESCRIPTION	QTY.	DESIGNATION NO.	PART NUMBER
Axial Cap., 0.01Mfd, 50v, +80, -20%	6	B (Bypass Cap)	5043-08980-00
Axial Cap., 0.1Mfd, 50v, +80, -20%	1	C1	5043-08996-00
Axial Cap., 10Mfd, 25v, ±20%	1	C2	5040-09343-00
Zener, 1N4740, 10v	2	D1, D2	5075-09135-00
Display, 16-Character A/N	1	DSPL1	5670-12308-00
9-Pin Header, Right Angle, .156	2	J1, J2	5791-10869-09
26-Pin Header, Right Angle, .100	1	J3	5791-10851-00
6-Pin Header, Right Angle, .156	1	J7	5791-10869-06
Resistor, 18K 1/4w, 5%	25	R1-R8, R21-R37	5010-08773-00
Resistor, 100K 1/4w, 5%	32	R38, R40, R42, R44, R46, R48, R50, R52, R54, R55, R61, R63, R65, R67, R69, R71, R73, R75-R83, R85	5010-09162-00
Resistor, 10K 1/2w, 5%	9	R39, R41, R43, R47, R53, R66, R70, R72, R84	5010-08981-00
Resistor, 1M 1/4w, 5%	1	R86	5010-10258-00
Resistor, 8.2K 1/2w, 5%	7	R45, R49, R51, R62, R64, R68, R74	5010-10927-00
I.C. 4049	3	U1-U3	5310-08975-00
I.C. 4001		U6, U7, U10, U11	5310-09882-00
I.C. 7180, Catode Driver	2	U8, U9	5680-08969-00
I.C. 6118, Anode Driver	2	U12, U13	5680-08968-00
Bally-Hi-Display PCB	1		5768-12408-00
Support Display5		S (Support)	03-8088-1

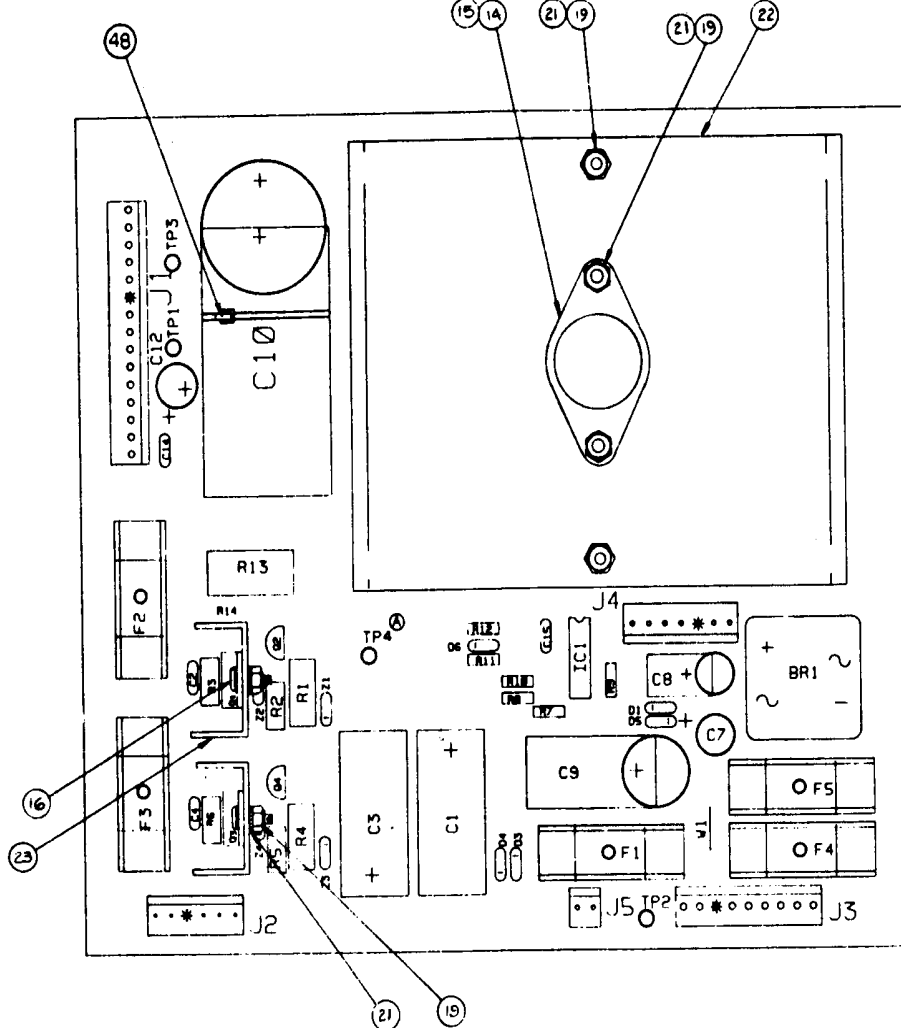

Power Supply

p/n D-12246

Item	Part No.	Ckt Designator	Description	Item	Part No.	Ckt Designator	Description
1	5765-12317-00		Power Supply PCB	26	5075-09060-00	ZR2, ZR4	Zener, 1N4764, 100v, 1w
2	5733-12060-01	F1-F5	Fuse Holder	27	5460-09424-00	IC1	IC, Volt. Reg., MC1723C5
3	5731-09432-00	F4, F5	Fuse, 7A., S-B, 250v	28	5010-09069-00	R3, R6	Resistor, 330K, 5%, 1/2w, C.F.
4	5731-12328-00	F1	Fuse, 3/8A., S-B, 250v	29	5010-10631-00	R2, R5	Resistor, 1.2K, 5%, 1/2w
5	5730-12327-00	F2, F3	Fuse 1/8 A., 250v	30	5010-09536-00	R1, R4	Resistor, 39K, 5%, 1w
6	5791-10862-15	J1	Connector, 15-pin Hdr, Sq Pin .156	31	5013-09426-00	R7	Resistor, 2.15K, 1%, 1/4w, C. F.
7	5791-10862-06	J2	Connector, 6-pin Hdr, Sq Pin .156	32	5013-09427-00	R8	Resistor, 4.99K, 1%, 1/4w, C. F.
8	5791-10862-09	J3	Connector, 9-pin Hdr, Sq Pin .156	33	5010-09541-00	R9	Resistor, 2.7K, 2%, 1/4w, C. F.
9	5100-09690-00	BR1	Bridge Rectifier, 35A., 200V	34	5010-09085-00	R10	Resistor, 1.5K, 5%, 1/4w, C. F.
10	5164-12154-00	Q1	Transistor, MJE15030, NPN	35	5010-09428-00	R11	Resistor, 1.5K, 2%, 1/4w, C. F.
11	5194-12155-00	Q3	Transistor, MJE15031, PNP	36	5010-09508-00	R12	Resistor, 270Ω, 2%, 1/4w, C. F37
12	5194-09055-00	Q2	Transistor, MPSD52, PNP	37	5012-09429-00	R13	Resistor, 0.12Ω, 5%, 5w
13	5164-09056-00	Q4	Transistor, MPSD02, NPN	38	5040-12324-00	C1, C3	Capacitor, 150 mfd, 160v, radial
14	5162-09425-00	Q5	Transistor, 2N6057, NPN	39	5043-09072-00	C2, C4	Capacitor, 0.1 mfd, 500v, disc
15	5701-09652-00		Thermal Pad T0-3	40	5040-09421-00	C7	Capacitor, 100 mfd, 25v, radial
16	4006-01003-06		Mach. Screw, 6-32 x 3/8	41	5040-09422-00	C8	Capacitor, 47 mfd, 50v, radial
17	4006-01003-08		Mach. Screw, 6-32 x 1/2	42	5040-09420-00	C9	Capacitor, 1000 mfd, electr, 25v, axial or radial
18	20-9229		Thermal Compound		5040-08893-00		Capacitor, 18,000 mfd, electr, 20v, axial
19	4406-01117-00		Nut, 6-32 Hex.	43	5040-09419-00	C10	Capacitor, 330 mfd, electr, 10v, radial
20	5010-09534-00	W1	Resistor, 0Ω	44	5040-09423-00	C12	Capacitor, 0.1 mfd, 50v, disc
21	4703-00007-00		Lockwasher, #6 Ext.	45	5043-09446-00	C14	Capacitor, 470 pfd
22	5705-12330-00		Heatsink 4"	46	5043-09065-00	C15	Terminal, #1502-1 (Test Post)
23	5705-09199-00		Heatsink 6030B	47	5824-09248-00	TP1-TP4	Tie Wrap, 8" Long
24	5070-09054-00	D1, D3 - D6	Diode, 1N4004	48	03-7947		
25	5075-09059-00	ZR1, ZR3	Zener, 1N5990, 3.9v, 1/2w				

NOTES:

- Heat sink compound must be applied between transistor and heat sink.
- Observe index mark on integrated circuit, polarity of capacitors and diodes, and position of transistors.
- The view of Q5 and its related heat sink and hardware is from the bottom of the heatsink, to clarify installation.

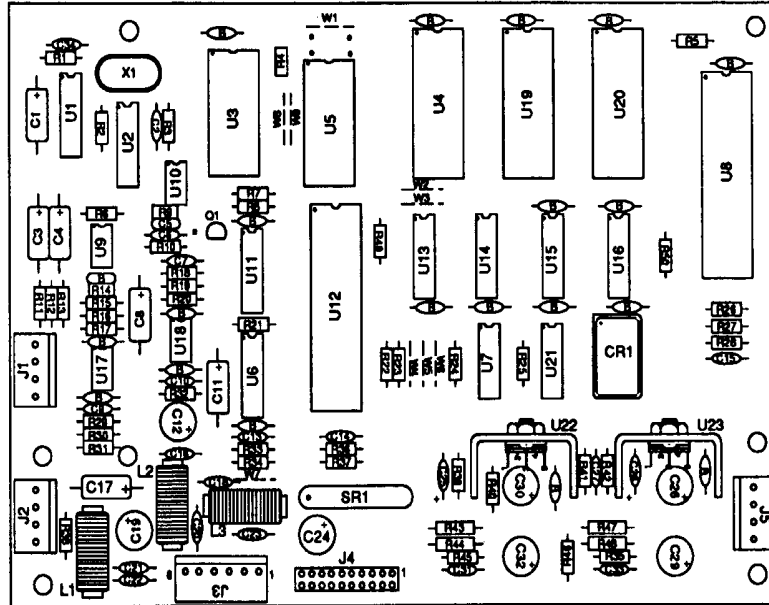

Audio Board Assembly

p/n D-11581-2003

Part No.	Ckt Designator	Description	Part No.	Ckt Designator	Description
5766-12130-00		Bare P. C. Board	5010-08998-00	R2, R3,	Resistor, 2.2K, 1/4w, 5%
5371-11087-00	U1	IC, D/A Conv, YM3012	5010-08983-00	R7-R9	Resistor, 3.3K, 1/4w, 5%
a) 5700-09006-00		Socket, IC, 16-pin (U1)	5010-08991-00	R1, R4, R5, R11,	Resistor, 4.7K, 1/4w, 5%
5370-11086-00	U3	IC, Sound Processor, YM215	R12, R26 - R28, R33,		
a) 5700-09004-00		Socket, IC, 24-pin (U3)	R36, R37, R49, R50		
5400-10320-00	U8	IC, μ Processor, MC68B09E	R14, R15	Resistor, 20K, 1/4w, 5%	
a) 5700-08985-00		Socket, IC, 40-pin (U8)	R17	Resistor, 10K, 1/4w, 5%	
A-5343-2003-5	U4	IC, Audio ROM 1	R8,	Resistor, 27K, 1/4w, 5%	
A-5343-2003-6	U19	IC, Audio ROM 2	R39	Resistor, 100K, 1/4w, 5%	
A-5343-2003-7	U20	IC, Audio ROM 3	R16	Resistor, 13K, 1/4W, 5%	
a) 5700-10176-00		Socket, IC, 28-pin	5010-09219-00	R38	Resistor, 8.2K, 1/4W, 5%
5371-09152-00	U11	IC, D/A Convtr, MC1408	5010-10258-00	R40	Resistor, 1M, 1/4w, 5%
5430-10322-00	U12	IC, PIA, MC68B21	5010-09179-00	R10	Resistor, 3.3M, 1/4w, 5%
5340-10139-00	U5	IC, RAM/S 5516-2 2Kx8	5010-09534-00	W9	Resistor, 0 Ω , 1/4w, 5%
5281-09487-00	U16	IC, Dual D Flipflop, 74LS74	5040-09343-00	C1, C3, C4, C8	Capacitor, 10 μ fd, 20v, \pm 20%
5281-10043-00	U13	IC, 74LS175	5040-10974-00	C12, C19, C24	Capacitor, 100 μ fd, 35v
5281-09235-00	U21	IC, Triple NAND, 74LS10	5040-09776-00	C26, C30	Capacitor, 470 μ fd, 16v; +50, -10%
5370-09321-00	U9, U10, U17	IC, Op Amp, MC1458	5040-12006-00	C29, C32	Capacitor, 1000 μ fd, 16v, 20%
5281-09215-00	U2	IC, Hex Inv, 74LS04	5041-09243-00	C25, C28	Capacitor, 10 μ fd, 10v, \pm 10%
5281-09246-00	U14	IC, 2-4 Dec, 74LS139	5043-08980-00	C5, B (17)*	Capacitor, 0.01 μ fd, 50v, +80, -20%
5281-09745-00	U15	IC, Dual Mux, 74LS138	5043-08996-00	C31, C33	Capacitor, 0.1 μ fd, 50v, \pm 20%
5370-09156-00	U22, U23	IC, Audio Amp, TDA2002	5043-09065-00	C13 - C15	Capacitor, 470 pfd, 50v, \pm 20%
a) 5705-09199-00		Heatsink, #6030B	5043-09492-00	C2, C34	Capacitor, 100 pfd, 50v, \pm 10%
b) 4006-01003-06		Mach. Screw, 6-32 x 3/8	5043-09844-00	C6	Capacitor, 47 pfd, 50v, \pm 20%
c) 4406-01117-00		Nut, 6-32 Hex.	5043-09845-00	C16, C18, C20 -	Capacitor, 1000 pfd, 50v, \pm 20%
d) 4703-00007-00		Lockwasher, #6 Ext.		C23, C27	
5160-10269-00	Q1	Transistor, 2N3904; NPN	5520-09020-00	X1	Crystal, 3.58 MHz
5060-10396-00	SP1	SIP 4.7K & 470pfd, 8R8C	5521-10931-00	CR1	Oscillator, 8 MHz
5010-09181-00	R44, R48	Resistor, 1.0 Ω , 1/2w, 5%	5551-09822-00	L1 - L3	Inductor, 4.7 μ H, 3A
5010-09161-00	R35, R45	Resistor, 2.2 Ω , 1/4w, 5%	5791-09437-00	J4	Connector, 20 pin, (Hdr), Rib. Cbl
5010-09361-00	R43, R46, R47	Resistor, 220 Ω , 1/2w, 5%	5791-10862-04	J1, J2, J5	Connector, 4 pin (Hdr)
5010-09358-00	R41, R42	Resistor, 1K, 1/4w, 5%	5791-10862-06	J3	Connector, 6 pin (Hdr)
			16-8850-250		P.C.B. I.D. Label
			20-9229		Thermal Compound

NOTES:

- * 17 capacitors (shown on diagram with "B" symbol) provide +5VDC filtering for ICs.
- All capacitors are ceramic, 50v, axial, unless otherwise noted.
- All resistors are 5%, 1/4w, Carbon Film, unless otherwise noted.

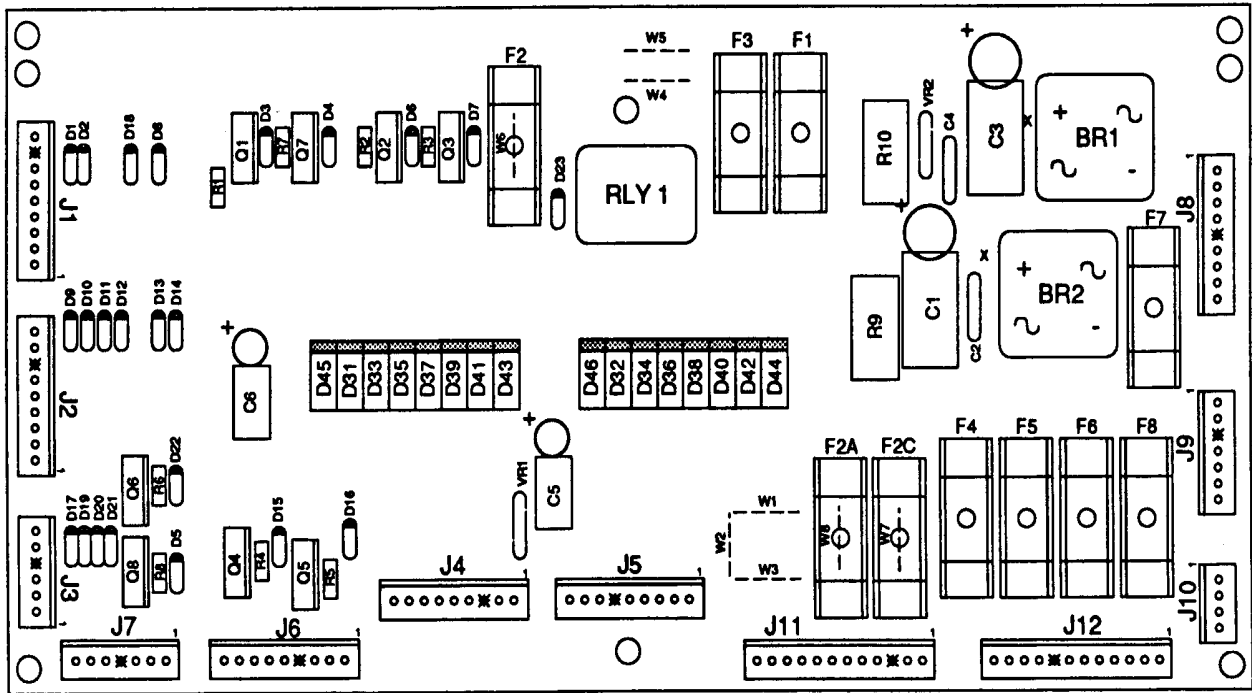

Aux Power Driver Unit Board

p/n D-12247-2003

Part No.	Ckt Designator	Description
5763-12184-00		Bare P.C. Board
5040-09537-00	C1, C3	Capacitor, 100 μ fd., 100v, Radial
5040-12181-00	C5, C6	Capacitor, 10 μ fd., 100v, Radial
5043-09072-00	C2, C4	Capacitor, 0.1 μ fd., 500v
5010-09160-00	R1 - R8	Resistor, 220 Ω , 1/4w C.F., 5%
5012-12238-00	R9	Resistor, 3.3K Ω , 5w, 10%
5010-09534-00	W1, W3, W4, W6	Resistor, 0 Ω , 1/4w
5017-12180-00	VR1, VR2	Varistor, 100v
5100-09690-00	BR1, BR2	Bridge Rectifier, 35A, 200v
5070-08785-00	D1 - D23	Diode, 1N4003
5070-09045-00	D31 - D46	Diode, MR501
5191-12179-00	Q1 - Q8	Transistor, TIP36C
5580-09555-01	K1	Relay, DPDT, 13A
5733-12060-01		Fuse Holder
5731-08665-00	F5, F6	Fuse, 2A, S-B, 250v
5731-09128-00	F1, F2A, F3, F4	Fuse, 2-1/2A, S-B, 250v
5731-09651-00	F2C,	Fuse, 5A, S-B, 250v
5731-06314-00	F7	Fuse, 4A, S-B, 250v
5731-09432-00	F8	Fuse, 7A, S-B, 250v
5791-10862-09	J1, J2, J4 - J6, J8	Connector, 9-pin Hdr, Sq Pin
5791-10862-07	J3, J7, J9	Connector, 7-pin Hdr, Sq Pin
5791-10862-12	J11, J12	Connector, 12-pin Hdr, Sq Pin
5791-10862-04	J10	Connector, 4-pin Hdr, Sq Pin
16-8850-252		P.C.B. I.D. Label

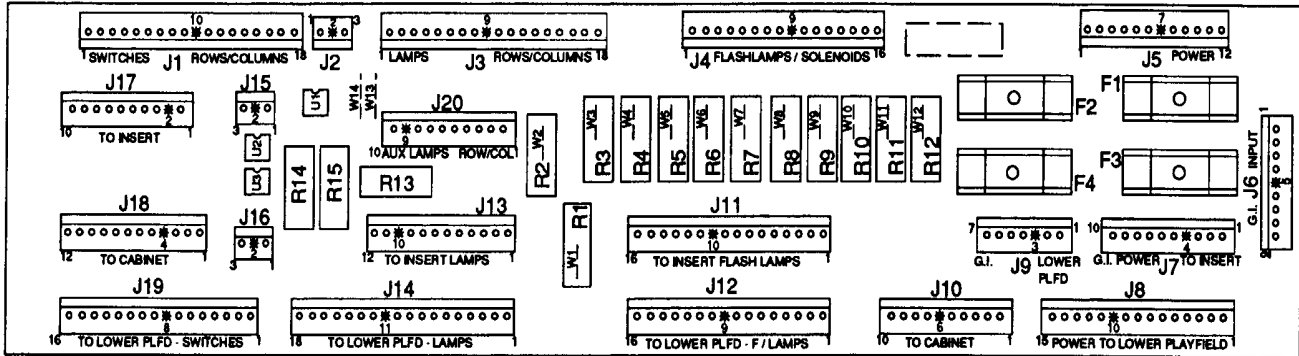

Backbox Interconnect Board

p/n D-12313-2003

Part No.	Ckt Designator	Description
5768-12332-00		Master Interconnect Board
5010-09534-00	R10, R11, R12	Resistor, 0Ω
5012-12238-00	R14, R15	Resistor, 3.3KΩ, 5w, 10%
5012-12337-00	R13	Resistor, 1.5KΩ, 5w, 10%
5012-10023-00	R1, R2, R6, R7	Resistor, 4Ω, 5w, 10%
5012-12163-00	R3, R8	Resistor, 11Ω, 5w, 10%
5012-10024-00	R4, R5, R9	Resistor, 5.6Ω, 5W, 10%
5490-10892-00	U1 - U3	Opto Isolator 4N25
5731-09651-00	F1-F4	Fuse, 5A.S.B., 250v
5733-12060-01		Fuse Holder, F1-F4
5791-10862-03	J2, J16	Connector, 3-pin Hdr Sq Pin .156
5791-10862-07	J9	Connector, 7-pin Hdr Sq Pin .156
5791-10862-09	J6	Connector, 9-pin Hdr Sq Pin .156
5791-10862-10	J7, J10, J20	Connector, 10-pin Hdr Sq Pin .156
5791-10862-12	J5, J13, J18	Connector, 12-pin Hdr Sq Pin .156
5791-10862-15	J8	Connector, 15-pin Hdr Sq Pin .156
5791-10862-16	J4, J11, J12, J19	Connector, 16-pin Hdr Sq Pin .156
5791-10862-18	J1, J3, J14	Connector, 18-pin Hdr Sq Pin .156
16-8850-243		P.C.B. I.D. Label

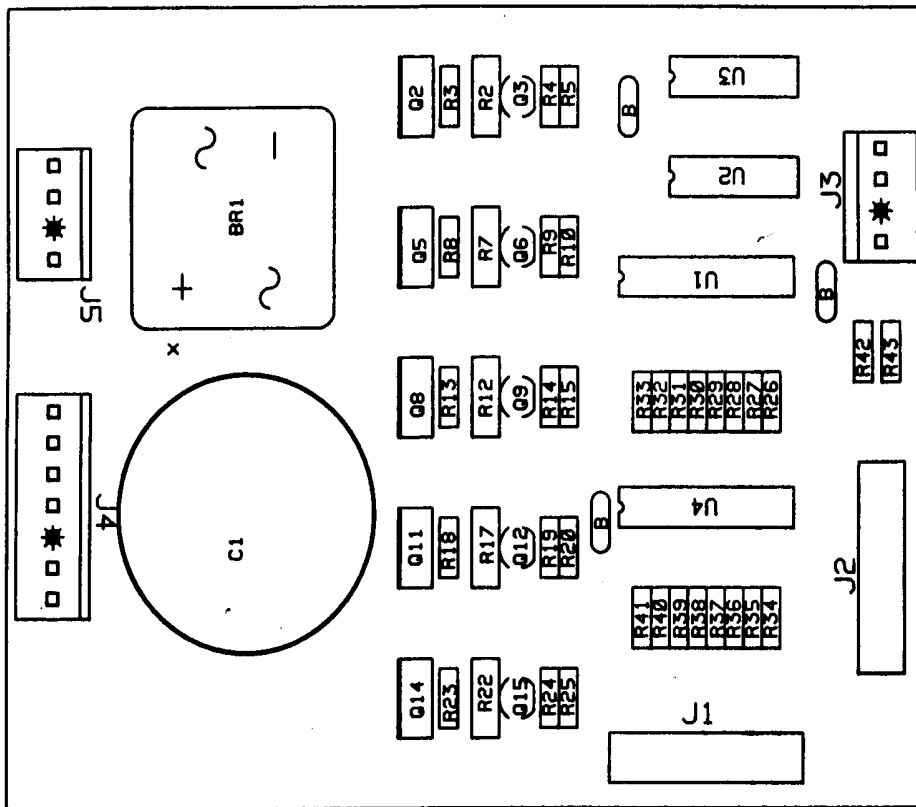

Sound Overlay Lamp Assembly p/n C-13286

Part Number	Ckt. Designator	Description
5768-12567-00		Bare PCB
5162-09410-00	Q2, Q5, Q8, Q11	Trans, TIP 122
5190-10270-00	Q3, Q6, Q9, Q12	Trans, 2N3904
5281-09486-00	U1	IC, 74LS374
5281-09500-00	U2	IC, 74LS32
5281-09247-00	U3	IC, 74LS02
5281-09308-00	U4	IC, 74LS245
5010-08993-00	R2, R7, R12, R17	Res. 68Ω 1/2W 5%
5010-08997-00	R3, R8, R13, R18	Res. 2.7KΩ 1/4W 5%
5010-08991-00	R4, R9, R14, R19	Res. 4.7KΩ 1/4W 5%
5010-09416-00	R5, R10, R15, R20	Res. 470Ω 1/4W 5%
5010-09358-00	R26-R41	Res. 1KΩ 1/4W 5%
5010-09034-00	R42, R43	Res. 10KΩ 1/4W 5%
5043-08980-00	Bypass Cap.	Cap. .01μF 50V
5100-09690-00	BR1	Bridge Rectifier 35A
5040-12313-00	C1	Cap. 15,000μF 25V Elect.
5791-09437-00	J1, J2	Header, 20 pin
5791-10862-04	J3, J4	Header, 4 pin
5791-10862-07	J4	Header, 7 pin

Right Flipper

p/n C-11626-R-3

Item	Part No.	Description
1	HW-30018-6	Wire, 18 AWG, Blue
2	03-7520-2	Ty-Wrap, Nylon
3	20-6516	Speednut, Tinnerman
4	5045-12098-00	Capacitor, 2.2 μ Fd, 250V, 20%
5	RM-21-06	Sleeve, Vinyl (Cap. leads)
6	4010-01066-06	Cap Screw, 10-32 x 3/8, SH
7	4701-00004-00	Lockwasher, #10 split
8	A-12111	Flipper Stop Assembly
9	FL-11630	Flipper Coil (Red), (* - Refer to Note 3)
10	4006-01017-04	Mach. Screw, 6-32 x 1/4, P-RH-S
11	01-7695	Solenoid Bracket
12	10-376	Coil Plunger Spring
13	B-10655-R	Crank Link Assembly, Right
a)	02-4179	Link Spacer Bushing
b)	4010-01086-14	Cap Screw, 10-32 x 7/8, SH
c)	4700-00023-00	Washer, 5/8 o.d. x 13/64 i. d. x 16 ga.
d)	4701-00004-00	Lockwasher, #10 split
e)	4410-01132-00	Nut, 10-32 ESNA
f)	A-10656**	Flipper Link Assembly
1.)	02-4219	Coil Plunger
2.)	20-9370-1	Spring Pin, 5/32 dia. x 7/16
3.)	03-8050-1	Flipper Link
g)	B-10657-R	Flipper Crank Assembly, Right
1.)	01-8073-R	Flipper Crank, Right
2.)	17-1037	Crank Washer
3.)	4010-01066-18	Cap Screw, 10-32 x 1-1/8, HCS
4.)	4410-01127-00	Nut, 10-32 Hex Hd.
5.)	4700-00107-00	Washer, 5/8 o.d. x 13/64 i. d. x 12 ga.
6.)	4701-00004-00	Lockwasher, #10 Split
7.)	RM-23-06	Tubing, H. S. 1/4 DWP
14	23-6577	Bumper Plug
15	03-7568	Flipper Bushing
16	4006-01005-06	Mach. Screw, 6-32 x 3/8, P-PH
17	4406-01117-00	Nut, 6-32 Hex
18	C-11627-R	Flipper Base Assembly, R.
19	06-14G	Insulating Blade
20	4105-01019-10	Sh. Metal Screw, #5 x 5/8
21	4701-00002-00	Lockwasher, #6 split
22	23-6622	Tape, Double-sided
23	03-7811	End of Stroke (EOS) Switch

** - Also see separate diagram

Left Flipper

p/n C-11626-L-3

(Parts listed replace same Items of C-11626-R-3)

Item	Part No.	Description
13	B-10655-L	Crank Link Assembly, Left
g)	B-10657-L	Flipper Crank Assembly, Left
1.)	01-8073-L	Flipper Crank, Left
18	C-11627-L	Flipper Base Assy, Left

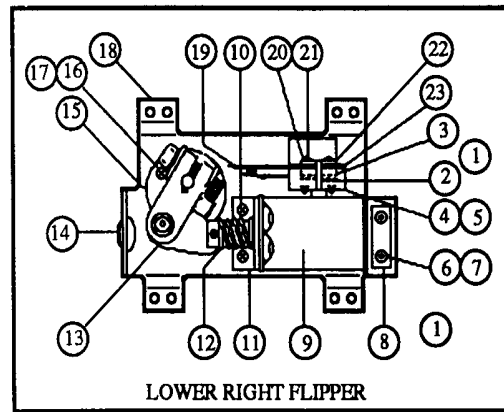

Flipper Assembly Notes:

- 1 Each Flipper Assembly on the Lower Playfield is mounted beneath the playfield, in conjunction with the plastic Flipper Paddle and Shaft (20-9250-5) and flipper Rubber (23-6519-4) on the upper side of the playfield.
- 2 The tip of the EOS Switch must travel 0.0150 (+ .010, - .000) inch, before the contacts fully open, with the flipper in the actuated position. The EOS Switch contacts must have a gap of 0.062 (\pm .015) inch. Adjustment of the EOS Switch must be made at a minimum distance of 0.25 inch from the switch body.
- 3 All moving elements of the assembly must operate freely, with no evidence of binding.
- 4 The large end of the Coil Plunger Spring (Item 12) must fit within the four lugs of the Solenoid Bracket.
- 5 For coil replacement, remove the Solenoid Bracket (Item 11) to prevent screw damage.
- 6 Use Loctite™ 242 when reattaching screws to the Flipper Stop Assembly, the Solenoid Bracket, and the Flipper Bushing.
- 7 When replacing the Bumper Plug (Item 14) to restore proper flipper operation, readjust the flipper paddle and shaft position.
- 8 Solid color blue wire connects to the banded end of each diode, mounted on the connector end of the Flipper Coil (Item 9). Trace color wire connects to the unbanded end of the diode.

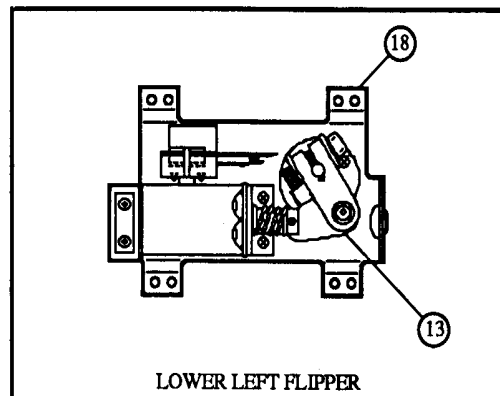

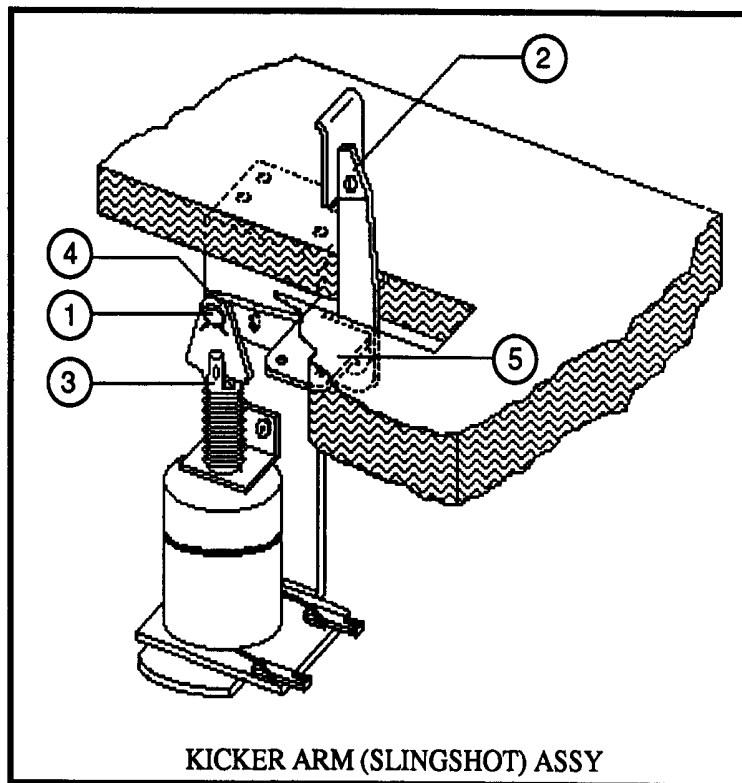

Kicker Arm ("Slingshot") Assembly

p/n B-12665
(Left & Right Kickers)

Item	Part No.	Description
1	12-6227	Clip, Hairpin
2	A-12664	Kicker Crank Assembly
3	A-5103	Coil Plunger Assembly
	02-2364	Coil Plunger
	20-8716-5	Roll Pin, 1/8 x 7/16
	03-8085	Armature Link
4	4700-00003-00	Flat Washer, .265 x .500 x.067
5	A-5653	Mounting Bracket Assy

Associated Parts for Right Kicker

Part No.	Description
B-11203-L-1	Coil & Bracket Assey
B-7572-1	Bracket & Stop Assy
01-8-508-S	Coil Retaining Bracket
4006-01017-06	Mach. Screw, 6-32 x 3/8
4406-01119-00	Nut, 6-32 ESN
AE-26-1500	Coil Assembly
03-7066	Coil Tubing

Associated Parts for Left Kicker

Part No.	Description
B-11203-R-1	Coil & Bracket Assy
B-7572-1	Bracket & Stop Assy
01-8-508-S	Coil Retaining Bracket
4006-01017-06	Mach. Screw, 6-32 x 3/8
4406-01119-00	Nut, 6-32 ESN
AE-26-1500	Coil Assembly
03-7066	Coil Tubing

Standup Target Assemblies

(Including Diode)

Item	Part No.	Description
1	B-11696-1	Standup Target (Blue)
1	B-11696-2	Standup Target (Green)
1	B-11696-4	Standup Target (Red)

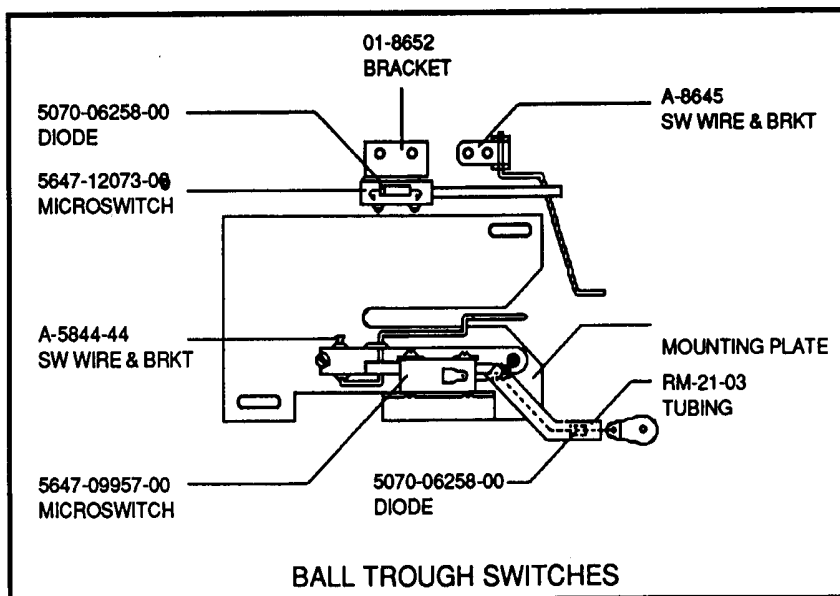
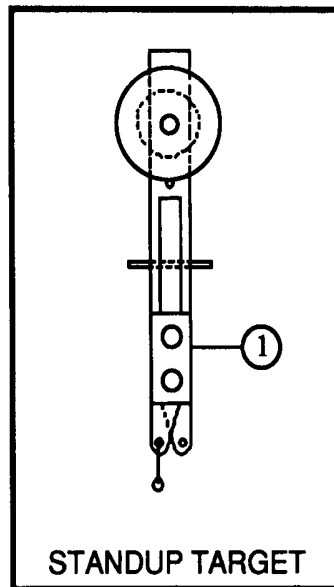

Ball Trough Switches

Part No.	Description
B-11348	Switch Plate Assembly
A-5844-44	Switch Wire & Bracket Assy
B-11349	Switch Mount Plate Sub-Assy
RM-21-03	#10 Tubing
4004-01060-08	MS 4-40 x 1/2 SL-PH-S
4005-01005-02	MS 5-40 x 1/8 P-PH
5070-06258-00	Diode, 1N4001, 1A
5647-09957-00	μSwitch E21-50H
5825-09373-00	#4 Solder Lug-bent
A-11680	Ball Trough Switch, Right
01-8652	Mounting Bracket
5647-12073-08	Submin. Switch
5070-06258-00	Diode, 1N4001, 1.0A
A-8645	Switch Wire & Bracket Assy

Ball Shooter Lane Feeder C-9638-3 & Associated Parts

Item	Part No.	Description
1	12-6227	Clip, Hairpin
2	A-8247	Eject Cam Assy
3	10-362	Ejector Spring (Plain)
4	A-6949-L	Spring Plate Assy
5	A-8050-1	Coil Plunger Assy
a)	02-3407-2	Coil Plunger
b)	20-8716-5	Roll Pin
c)	03-8085	Armature Link
6	4700-00030-00	Flat Washer, 17/64 x 1/2 x 15 ga
7	4700-00103-00	Flat Washer, 17/64 x 1/2 x 28 ga.
8	A-8268-2	Mounting Bracket Assy

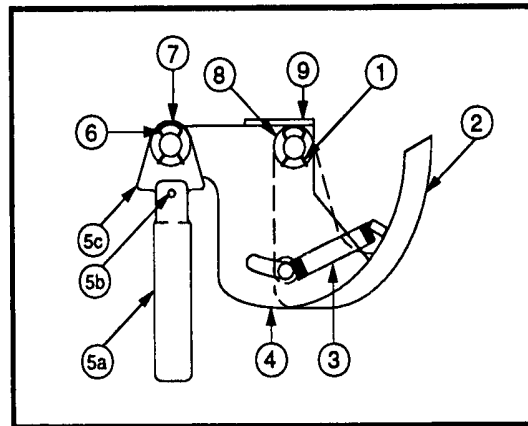

Associated Parts

B-9362-L-1	Coil & Bracket Assy
B-7572-1	Bracket & Stop Assy
01-8-508-S	Coil Retaining Bracket
4006-01017-06	Mach. Screw, 6-32 x 3/8
4406-01119-00	Nut, 6-32 ESN
AE-23-800	Coil Assembly
03-7066	Coil Tubing

Outhole Kicker Assembly p/n B-8039-2

Item	Part No.	Description
1	A-6378	Mounting Plate Assy
2	A-8335	Coil Plunger Assy
a)	02-2364	Coil Plunger
b)	20-8716-5	Roll Pin, 1/8 x 7/16
c)	01-4251	Ball Return Link
3	03-7066	Coil Tubing
4	A-6889	Kicker Lever Assy
5	A-8038	Coil Stop Assy
6	AE-23-800	Coil Assy
7	03-7176-1	Striker Ring
8	10-101-4	Spring-Reset
9	20-8712-25	"E" Ring, 1/4" Shaft
10	4006-01003-03	Mach. Screw, 6-32 x 3/16

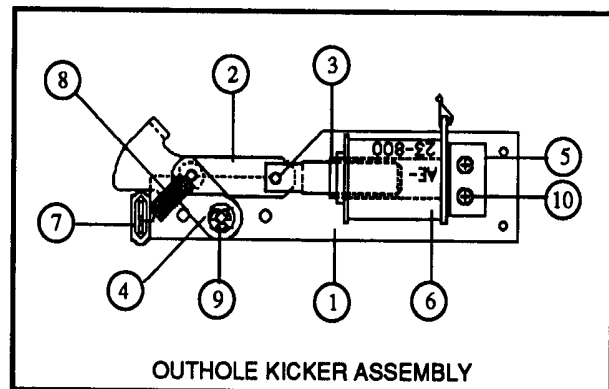

OUTHOLE KICKER ASSEMBLY

Jet Bumper Assembly

p/n B-9414

Item	Part No.	Description
1	A-4754	Bumper Ring Assy
2	03-6009-A5	Bumper Base-Wht
3	03-6035-5	Bumper Wafer-Wht
4	03-7443-5	Bumper Body-Wht
5	10-7	Spring-Jet Bumper
6	A-11199	Socket & Bulb Assy
7	03-8254-9	Bumper Cap

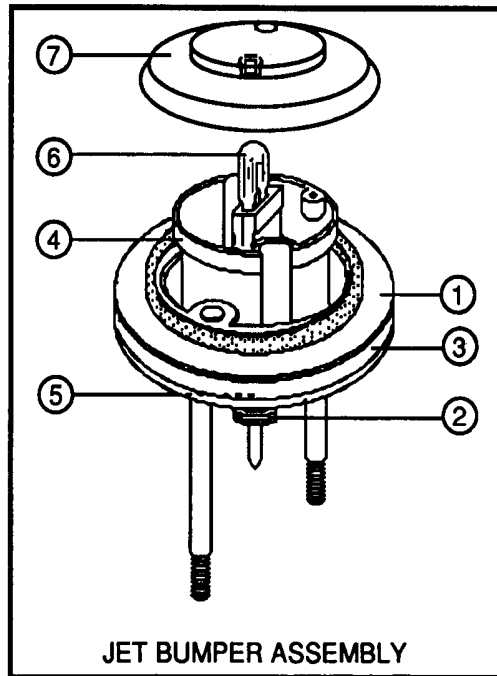

JET BUMPER ASSEMBLY

Jet Bumper Coil Assembly

p/n B-9415-1

Item	Part No.	Description
1	B-7417	Bracket & Stop Assy
2	01-1747	Coil Retaining Bracket
3	01-5492	Armature Link, Steel
4	01-5493	Armature Link, Bakelite
5	02-3406-1	Coil Plunger
6	10-326	Armature Spring
7	AE-23-800	Coil Assembly
8	4006-01017-04	Mach. Screw, 6-32 x 1/4
9	03-7066	Coil Tubing

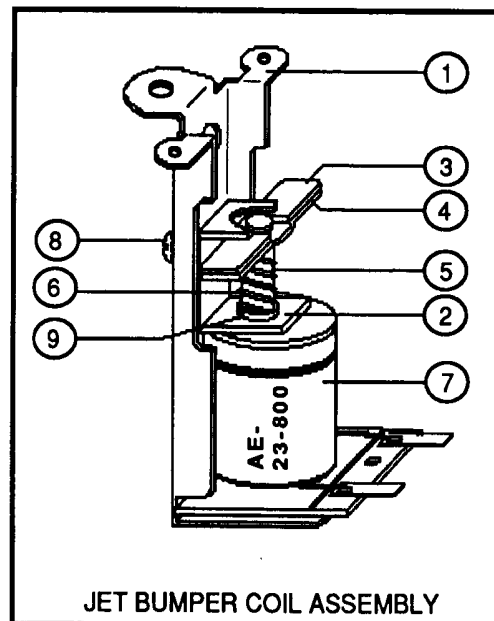

JET BUMPER COIL ASSEMBLY

Knocker Assembly

p/n B-10686-1

Item	Part No.	Description
1	A-5387	Coil Plunger Assembly
a)	02-2653	Coil Plunger
b)	03-6013	Bell Arm Ext.
2	B-7409-2	Mtg. Bracket Assembly
3	AE-23-800	Coil Sub-Assembly
4	01-8-508-T	Coil Retaining Bracket
5	23-6420	Rubber Grommet
6	4008-01017-06	Mach. Screw, 8/32 x 3/8
7	H-11835	Knocker Cable
8	03-7067-5	Coil Tubing

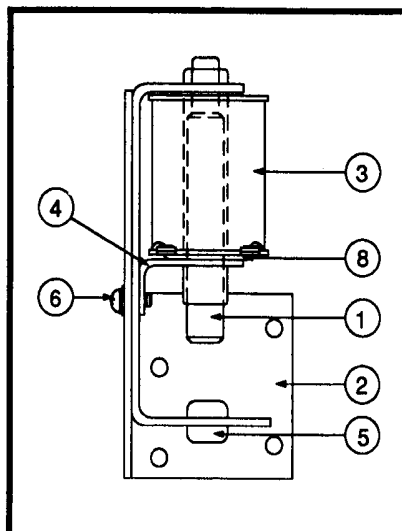

Top Ramp Gate p/n B-13380

Item	Part No.	Description
1	01-9527	Mounting Bracket
2	A-12958	Frame & Eyelet Assembly
3	4006-01003-05	M.S. 6-32 x .31 P-PHS
4	A-13381	B/G Armature Assembly
5	10-120	Compression Spring
6	SM2-35-4000	Coil Assembly w/ Diode
7	4700-00089-00	.172 x 44 Flat Washer
8	4701-00003-00	#8 Split Lock Washer
9	4008-01021-07	#8-32 x .44 P-RH BR

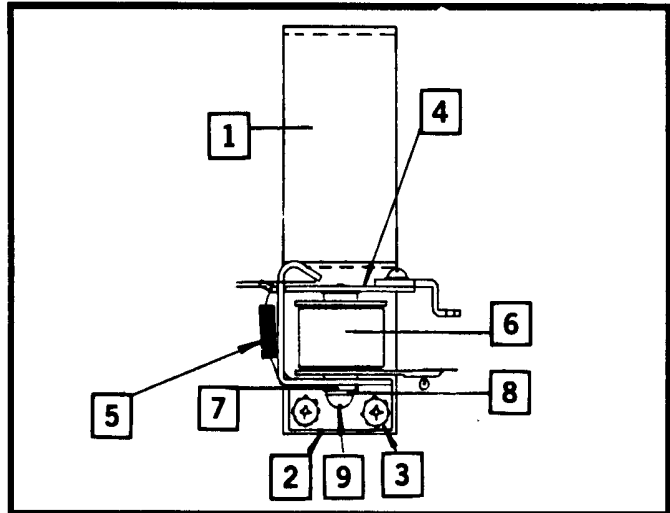

Multi-ball Kicker Assembly (Ball Locker) p/n C-13386

Item	Part No.	Description
1	A-13270	Armature Assembly
2	AE-23-800	Coil Sub-assembly
3	01-8-508-T	Solenoid Bracket
4	01-8918	Coil Mounting Bracket
5	10-135	Solenoid Spring
6	03-7067-5	Coil Tubing
7	23-6420	Rubber Grommet
8	4008-01017-04	M.S. 8-32 x .25L P-RH-S

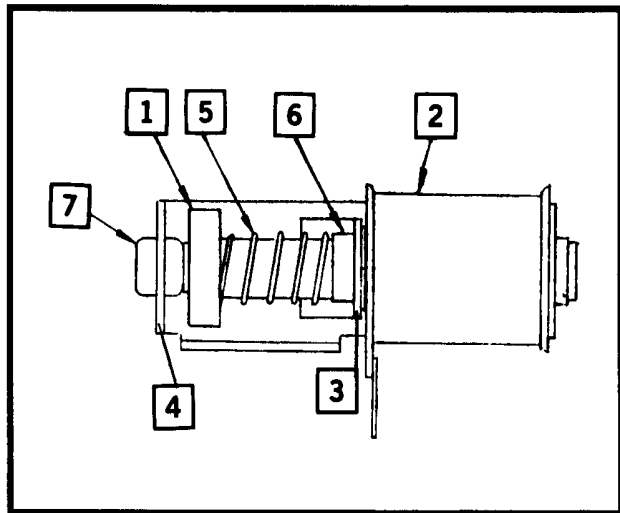

Ball Shooter p/n B-12445-1

Item	Part No.	Description
1	03-7357	Sleeve
2	10-149	Rod Spring
3	20-9253-7	Rod Assembly
4	21-6645-1	Ball Shooter Housing
5	10-148-1	Shooter Spring
6	20-8718-1	"C" Ring
7	23-6327	Shooter Tip

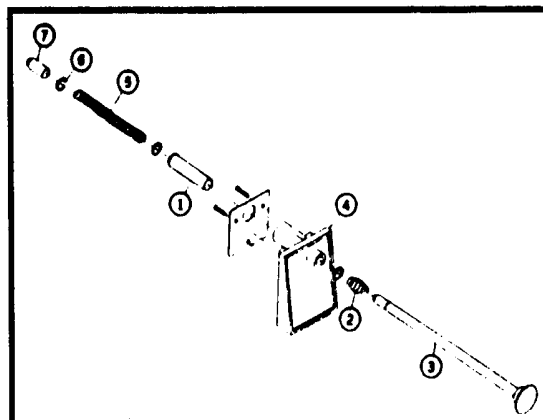

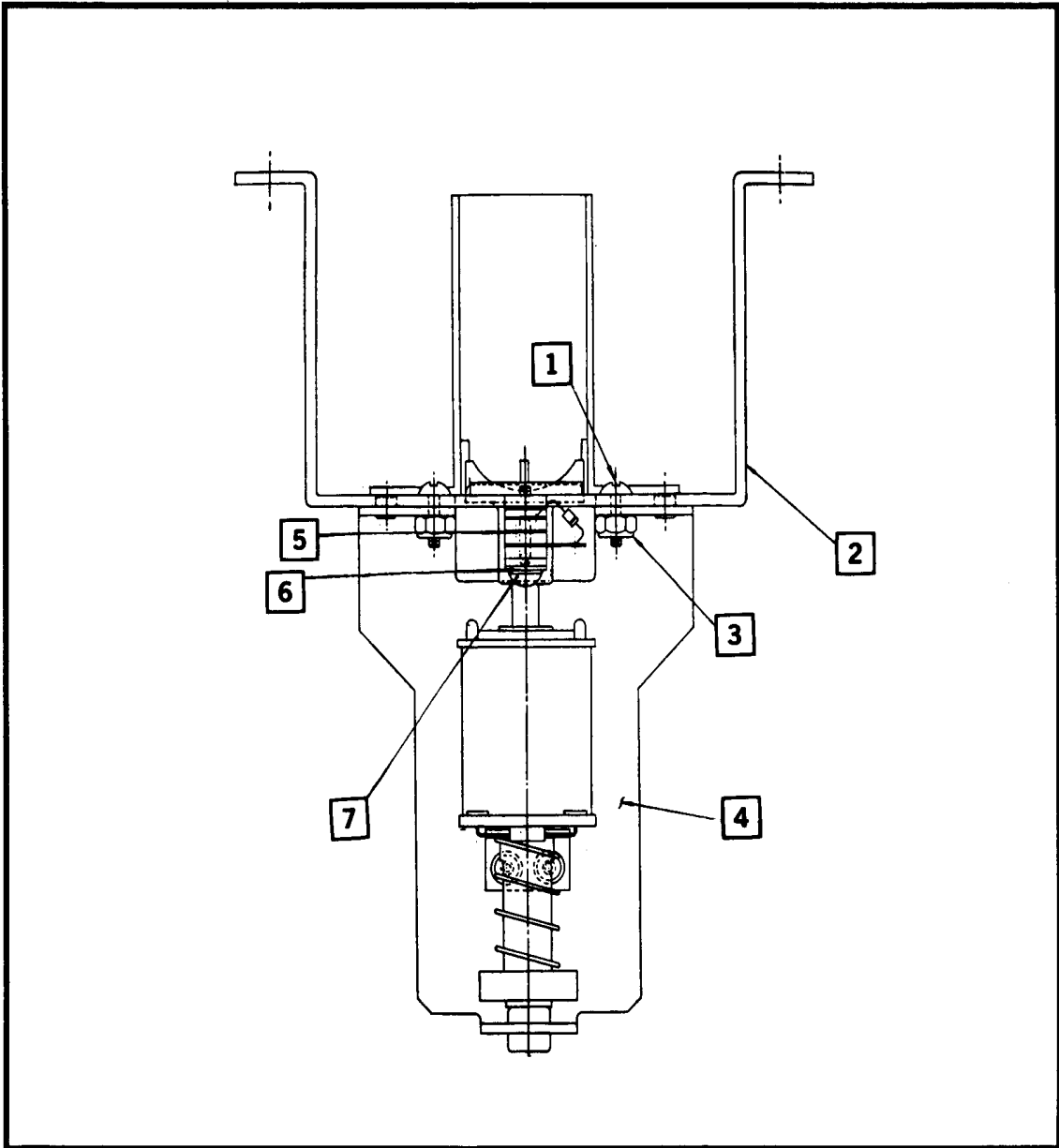

Ball Popper & Extension Assembly
p/n D-13306

Item	Part No.	Description	*Ball Popper Assembly	
			Part No.	Description
1	4008-01016-08	8-32 x 1/2 M.S. P-RH	A-11336	Armature Assy
2	B-13307	Extension Bracket Assembly	A-11721	Bracket Assy
3	4408-01119-00	8-32 Hex Nut E.S.N.	AE-23-800	Coil Assy
4	D-11335-2	Ball Popper Assembly*	B-11631	Popper Brkt Assy
5	A-12792	Switch & Diode Assembly	03-7067	Coil Tubing
6	01-3670-1	Switch Plate	03-8053	Popper Cap
7	4005-01051-10	5-40 x 5/8 M.S.-SL-RH	10-135	Coil Plunger Spring
			20-9314-7	Dowl Pin
			23-6420	Grommet
			4008-01017-05	M.S. 8-32 x 5/16 P-RH-S

1 Bank Drop Target Assembly p/n C-13312-4

Item	Part No.	Description
1	03-8033	Target
2	B-11213	Target Sub-assembly
3	4408-01119-00	Nut 8-32 ESNA
4	A-11397	Stop Bracket Assembly
5	AE-23-800	Coil Assembly
6	01-8413	Coil Mtg. Bracket
7	A-11388	Pl. & Reset Pl. Assy
8	4008-01016-10	M.S. 8-32 x 5/8 P-RH
9	20-8712-25	"E" Ring 1/4 Shaft
10	10-364	Extention Spring (not shown)
11	4700-00016-00	Washer
12	C-1331-L	1 Bank Opto Assy
13	10-392	Compression Spring
14	20-7812-18	"E" Ring 3/16 Shaft
15	4700-00072-00	Washer
16	23-6626	Grommet
17	03-7066-4	Tubing

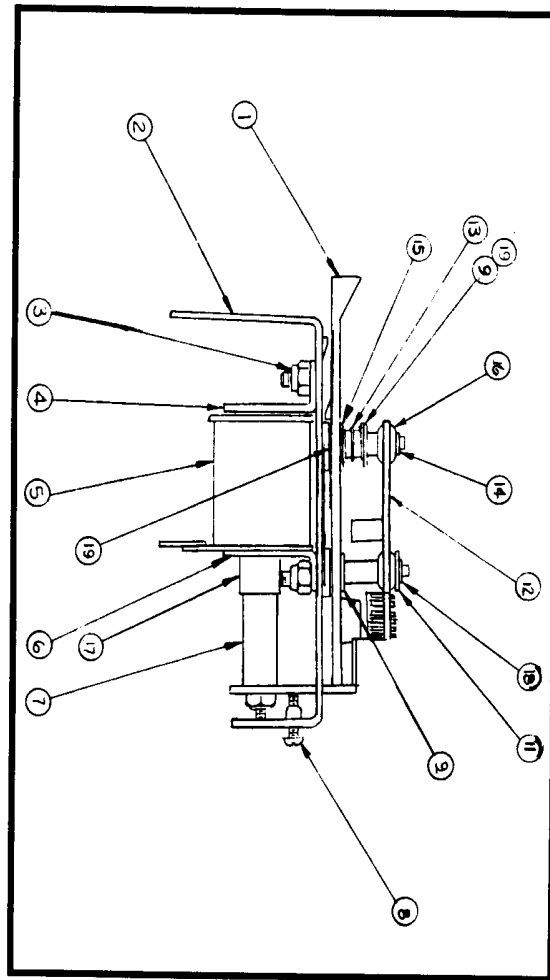

Bell Assembly p/n C-8461-1

Item	Part No.	Description
1	B-8459	"M" Mtg. Relay Frame Assy
2	B-8460	Bell & Mtg. Plate Assembly
3	B-8462	Armature Assembly
4	SM-26-600	Coil Assembly
5	SW-10A-52	Bell Switch
6	10-362	Extention Spring
7	20-6516	Speed Nut
8	4006-01003-04	M.S. 6-32 x 1/4 P-PH-S
9	4008-01021-07	M.S. 8-32 x 7/16 P-RH-BR
10	4105-01001-14	S.M.S. 5 x 7/8 P-PH
11	4700-00089-00	.172 x 7/16 .062 BR.
12	4701-00003-00	8 Split
13	HW-30122-4	22 Gage Jumper Wire
14	5043-09072-00	.01 μ FD Capacitor Cer. Disc (not shown)

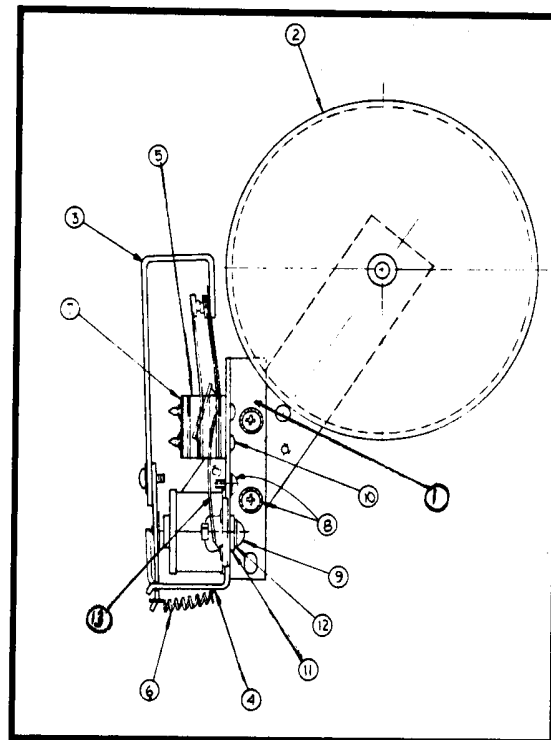

Playfield Posts

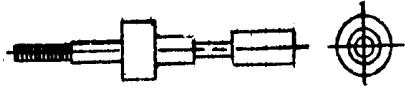
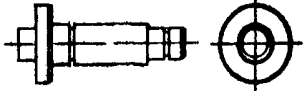
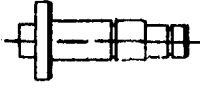
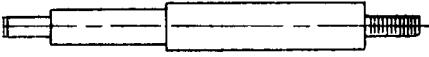
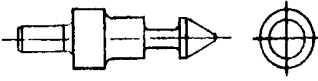
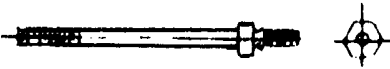
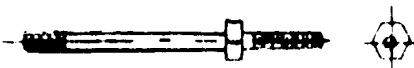
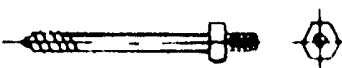
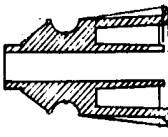
	
02-4008	02-4271-2
	
02-4271-3	02-4315
	
02-4321	02-4424
	
02-4425	02-4426
	
03-8319	

Relay Board p/n C-11998-1

Part No.	Description
5010-09534-00	0 Ω Resistor
5070-09054-00	Diode, 1N4004, 1.0 A
5580-09555-01	Relay, DPDT, 24 V, 13 A
5768-12243-00	DP Mount Relay PCB
5791-12273-02	Header, 2-pin, sq. posts
5791-12273-07	Header, 7-pin, sq. posts

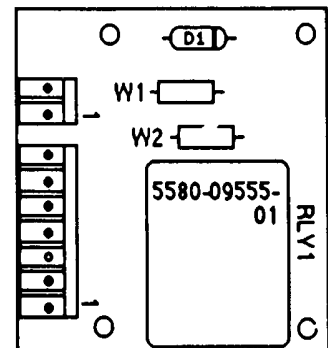

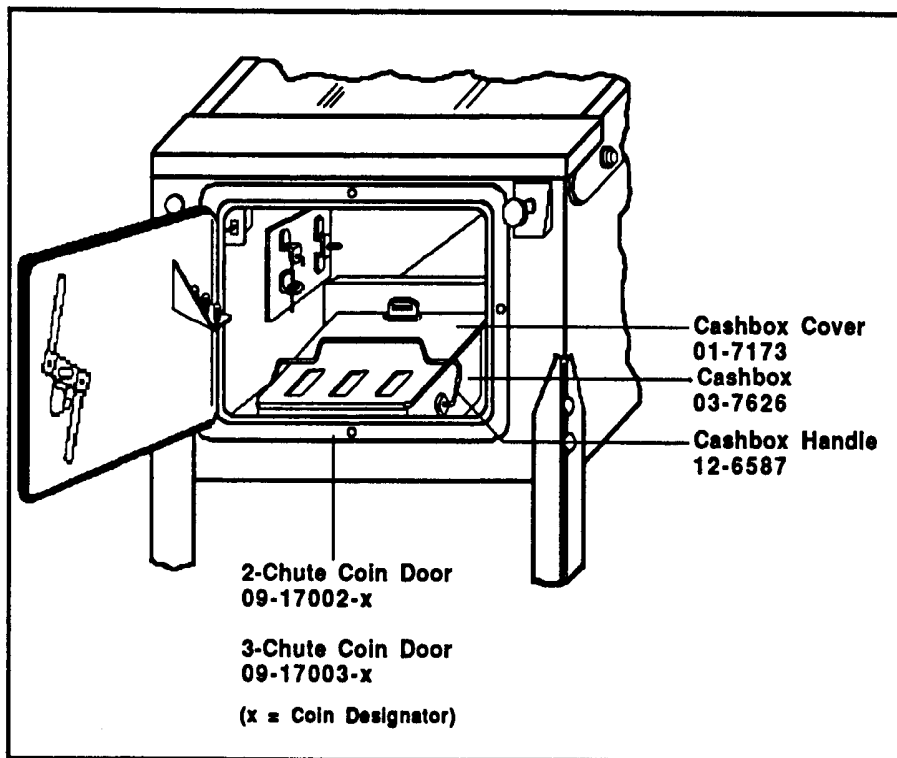
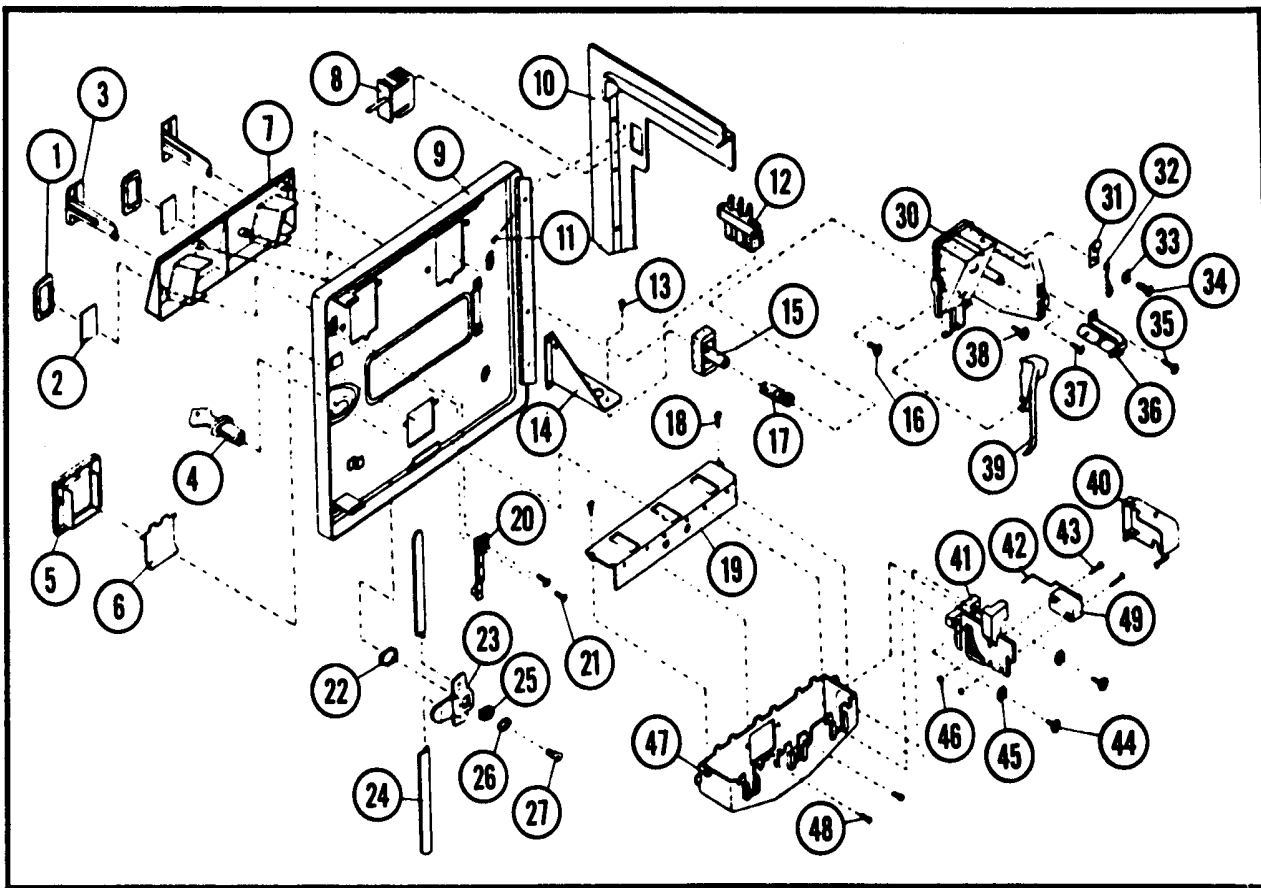

COIN DOOR ASSEMBLY
USA Door with decals, p/n C-13155-1
 2-Chute Door - **09-17002-x**
 3-Chute Door - **09-17003-x**
 ("x" is the country designator)

Item	Part Number	Description	Quantity
1	27-1038	Button Cover	2 or 3
2	27-1041-1-54	Price Panel	2 or 3
3	27-1026-1-15	Coin Entry Plate	2 or 3
4	27-1016	Lock Assembly	1
5	27-1061-1	Coin Return - Bezel	1
6	27-1062	Coin Return Flap	1
7	27-1021	Button Housing - 2-slot	1
	27-1022	Button Housing - 3-slot	1
8	27-1111	Interlock Switch	1
9	27-1006-1	Coin Door , 2-Slot	1
	27-1007-1	Coin Door , 3-Slot	1
10	27-1005	Coin Door Frame	1
11	27-1003	M/C Screw, 6-32 x 3/16	4
12	27-1008	Diagnostic Switch	1
13	27-1101	M/C Screw, 4-40 x 1/4	2
14	27-1102	Bracket, Diagnostic Switch	1
15	27-1037	Button	2 or 3
16	27-1078	M/C Screw, 6-32 x 3/8	2 or 3
17	27-1039	Conical Spring	2 or 3
18	27-1079	Self-tapping Screw, #6 x 1/4	2
19	27-1077-1	Coinbox Cover	1
20	27-1066	Slam Switch	1
21	27-1067	M/C Screw, 4-40 x 1/2	2
22	27-1017	Nut (key)	1
23	27-1012	Locking Cam	1
24	27-1011	Locking Arm	2
25	27-1020	Washer	1
26	27-1018	Star Washer	1
27	27-1019	M/C Screw 1/4-28 x 5/16	1
30	27-1112	Coin Inlet Chute	2 or 3
31	27-1088	Cable Clamp	2 or 3
32	27-1025	Key Hook	1
33	27-1086	Washer, #6	2 or 3
34	27-1078	M/C Screw, 6-32 x 3/8	1 or 2
	27-1113	M/C Screw, 6-32 x 7/16	1
35	27-1079	Self-tapping Screw, #6 x 1/4	2 or 3
36	27-1084	Lamp Socket	2 or 3
	27-1085	Lamp	2 or 3
37	27-1096	Self-tapping Screw, #5 x 3/8	2 or 3
38	27-1087	M/C Screw, 6-32 x 5/8	2 or 3
39	27-1082	Lever Arm	2 or 3
40	27-1097	Switch Cover	2 or 3
41	27-1091-1	Coin Accept Chute	2 or 3
42	27-1075	Wire Form (small)	2 or 3
	or		
	27-1093	Wire Form (large)	
43	27-1094	M/C Screw, 4-40 x 7/8	4 or 6
44	27-1087	M/C Screw, 6-32 x 5/8	4 or 6
45	27-1086	Washer, #6	4 or 6
46	27-1095	Nut, 4-40 ESNA	4 or 6
47	27-1076-1	Coin Return Box	1
48	27-1078	M/C Screw, 6-32 x 3/8	2
49	27-1092	Microswitch	2 or 3

GAME SHOW Lamp Matrix

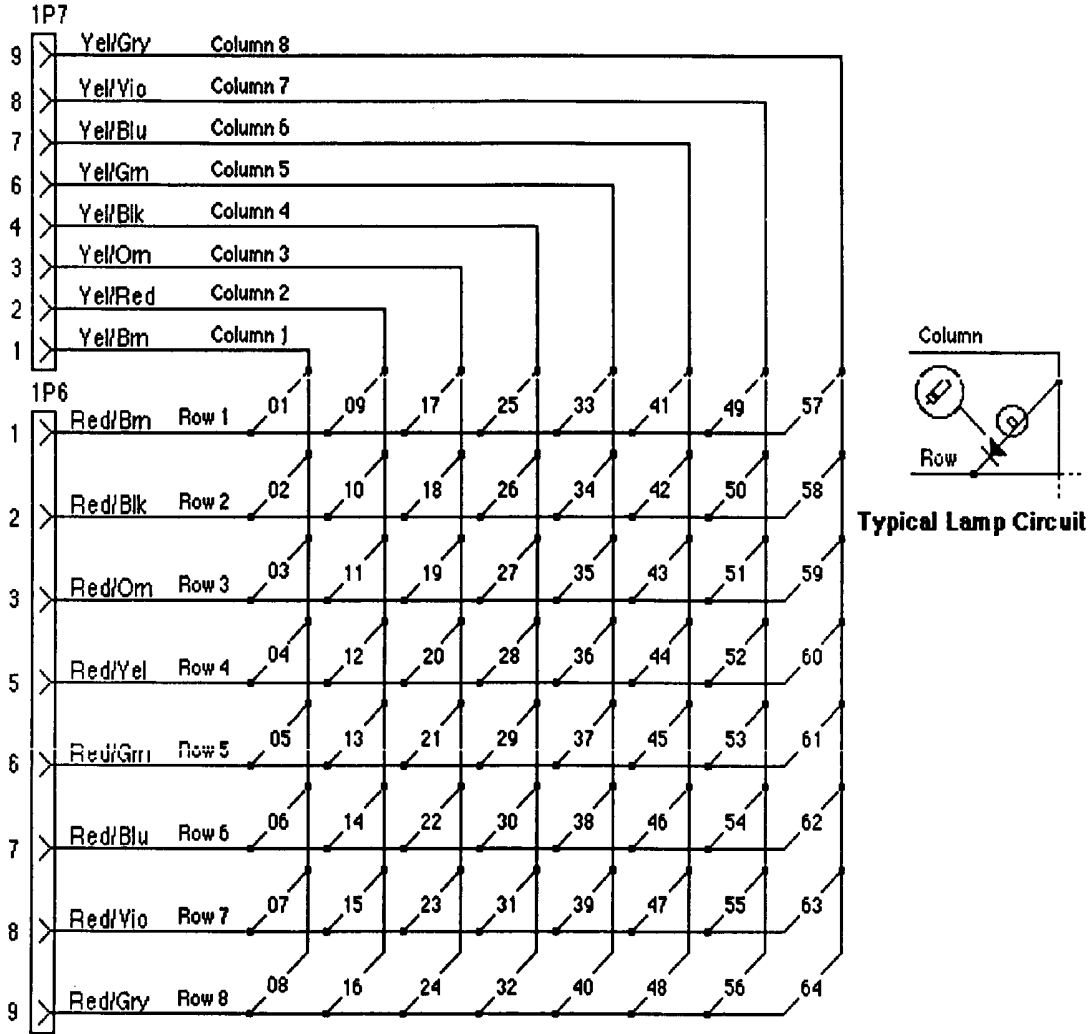

column	1	2	3	4	5	6	7	8
row	Q86 YEL-BRN 1J7-1	Q84 YEL-RED 1J7-2	Q82 YEL-ORN 1J7-3	Q80 YEL-BLK 1J7-4	Q88 YEL-GRN 1J7-6	Q86 YEL-BLU 1J7-7	Q84 YEL-VIO 1J7-8	Q82 YEL-GRY 1J7-9
1 Q80 RED-BRN 1J6-1	Shoot Again 1	Bonus 1K 9	Wheel 5K 17	Wheel 45K 25	TRUCK Letter-T 33	Big Bucks 41	2 Million Left 49	Top Lane Right 57
2 Q81 RED-BLK 1J6-2	Wheel 5X 2	Bonus 2K 10	Wheel 10K 18	Wheel 50K 26	TRUCK Letter-R 34	Top Lane Red 42	Left Spot Letter 50	Grand Prize 58
3 Q82 RED-ORN 1J6-3	Bonus Multiplier 1X 3	Bonus 4K 11	Wheel 15K 19	TV Letter-T 27	TRUCK Letter-U 35	Top Lane Red 43	Left Extra Ball 51	Collect TV 59
4 Q83 RED-YEL 1J6-5	Bonus Multiplier 2X 4	Bonus 8K 12	Wheel 20K 20	TRIP Letter-V 28	TRUCK Letter-C 36	Back Panel Car 44	2 Million Right 52	Collect Trip 60
5 Q84 RED-GRN 1J6-6	Bonus Multiplier 4X 5	Bonus 16K 13	Wheel 25K 21	TRIP Letter-T 29	TRUCK Letter-K 37	Left Extra Ball 45	Right Spot Letter 53	Collect Truck 61
6 Q85 RED-BLU 1J6-7	Bonus Multiplier 8X 6	Bonus 32K 14	Wheel 30K 22	TRIP Letter-R 30	Wheel 250,000 38	Wheel 4 Million 46	Right Spinner 54	Collect Car 62
7 Q86 RED-VIO 1J6-8	Center Spinner 7	Bonus 64K 15	Wheel 35K 23	TRIP Letter-I 31	Wheel Hold Bonus 39	Wheel Extra Ball 47	Top Lane Left 55	Collect Prizes 63
8 Q87 RED-GRY 1J6-9	Center Nudge 8	Bonus 128K 16	Wheel 40K 24	TRIP Letter-P 32	Wheel 1 Million 40	Right Extra Ball 48	Top Lane Middle 56	Right Lock 64

LAMPS

Item Description

- 1 Shoot Again
- 2 Wheel 5X
- 3 Bonus Multiplier 1X
- 4 Bonus Multiplier 2X
- 5 Bonus Multiplier 5X
- 6 Bonus Multiplier 8X
- 7 Center Spinner
- 8 Center Nudge
- 9 Bonus 1K
- 10 Bonus 2K
- 11 Bonus 4K
- 12 Bonus 8K
- 13 Bonus 16K
- 14 Bonus 32K
- 15 Bonus 64K
- 16 Bonus 128K
- 17 Wheel 5K
- 18 Wheel 10K
- 19 Wheel 15K
- 20 Wheel 20K
- 21 Wheel 25K
- 22 Wheel 30K
- 23 Wheel 35K
- 24 Wheel 40K
- 25 Wheel 45K
- 26 Wheel 50K
- 27 T (in TV)
- 28 V (in TV)
- 29 T (in TRIP)
- 30 R (in TRIP)
- 31 I (in TRIP)
- 32 P (in TRIP)
- 33 T (in TRUCK)
- 34 R (in TRUCK)
- 35 U (in TRUCK)
- 36 C (in TRUCK)
- 37 K (in TRUCK)
- 38 Wheel 250,000
- 39 Wheel Hold Bonus
- 40 Wheel 1 Million
- 41 Big Bucks
- 42 Top Lane Red
- 43 Top Lane Red
- 44 Back Panel Car
- 45 Left Extra Ball
- 46 Wheel 4 Million
- 47 Wheel Extra Ball
- 48 Right Extra Ball
- 49 2 Million Left
- 50 Left Spot Letter
- 51 Left Extra Ball
- 52 2 Million Right
- 53 Right Spot Letter
- 54 Right Spinner

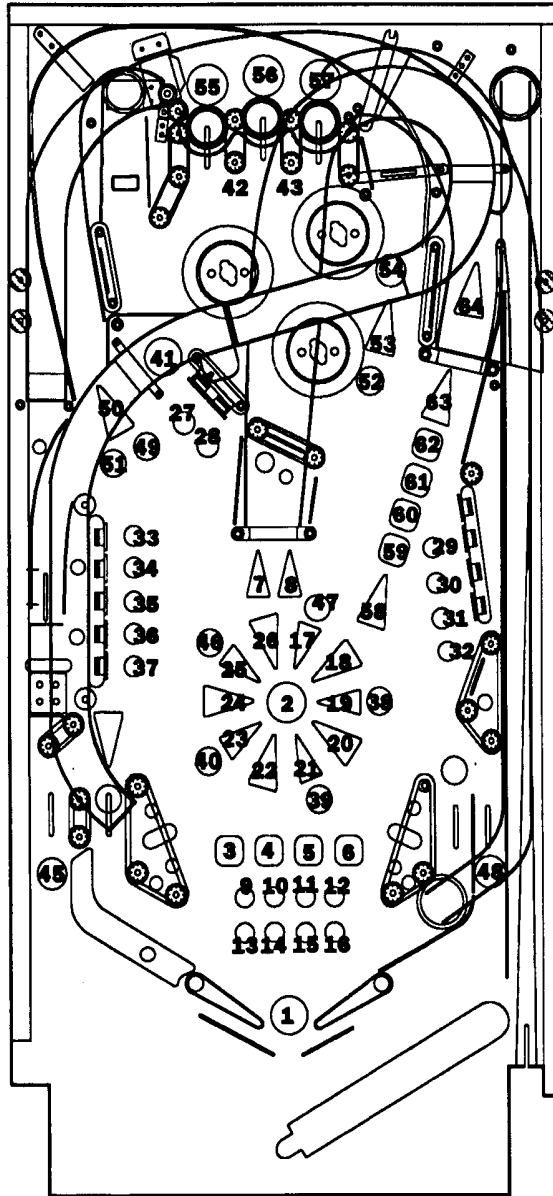

- 55 Top Lane Left
- 56 Top Lane Middle
- 57 Top Lane Right
- 58 Grand Prize
- 59 Collect TV
- 60 Collect Trip
- 61 Collect Truck
- 62 Collect Car
- 63 Collect Prizes
- 64 Right Lock

GAME SHOW Switch Matrix

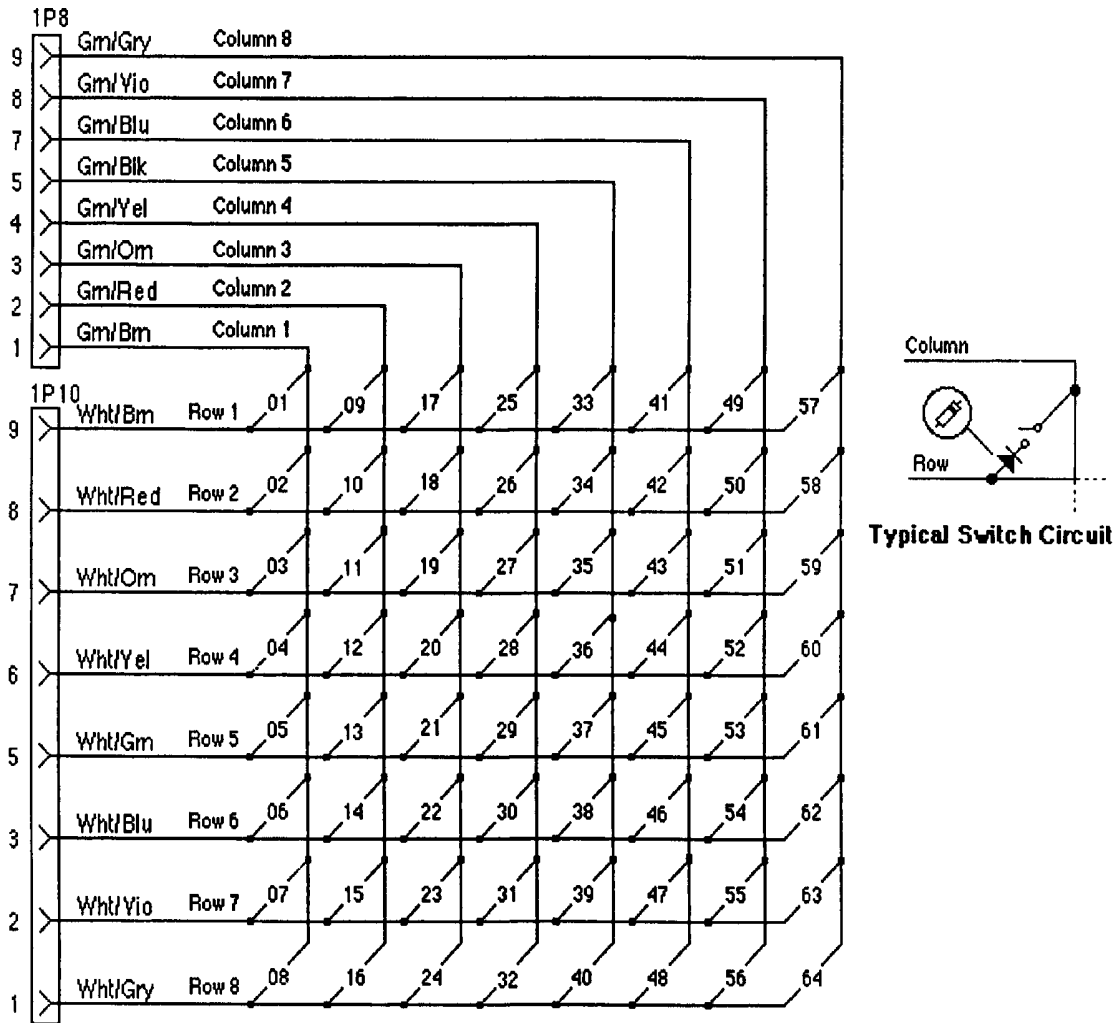

column	1 Q45	2 Q49	3 Q44	4 Q48	5 Q43	6 Q47	7 Q42	8 Q46
row	GRN-BRN 1J8-1	GRN-RED 1J8-2	GRN-ORN 1J8-3	GRN-YEL 1J8-4	GRN-BLK 1J8-5	GRN-BLU 1J8-7	GRN-VIO 1J8-8	GRN-GRY 1J8-9
1 WHT-BRN 1J10-9	Plumb Bob Tilt 1	Not Used 9	Top Lane, Left 17	Easy Spin 25	Prize Letter T in TRUCK 33	Spin Wheel 41	Not Used 49	Right Flipper 57
2 WHT-RED 1J10-8	Not Used 2	Outhole 10	Top Lane, Middle 18	Center Ramp 26	Prize Letter R in TRUCK 34	Right Spinner 42	Not Used 50	Left Flipper 58
3 WHT-ORN 1J10-7	Credit Button 3	Trough 1, Right 11	Top Lane, Right 19	Prize Letter T in TV 27	Prize Letter U in TRUCK 35	Spot Letter 43	Not Used 51	Not Used 59
4 WHT-YEL 1J10-6	Right Coin 4	Trough 2, Left 12	Right Ramp 20	Prize Letter V in TV 28	Prize Letter C in TRUCK 36	Not Used 44	Not Used 52	Left Jet 60
5 WHT-GRN 1J10-5	Center Coin 5	Not Used 13	Ball Popper 21	Prize Letter T in TRIP 29	Prize Letter K in TRUCK 37	Left Outlane 45	Not Used 53	Right Jet 61
6 WHT-BLU 1J10-3	Left Coin 6	Shooter Lane 14	Not Used 22	Prize Letter R in TRIP 30	Not Used 38	Left Return 46	Not Used 54	Bottom Jet 62
7 WHT-VIO 1J10-2	Stam Tilt 7	Not Used 15	Left Lockup 23	Prize Letter I in TRIP 31	Drop Target Car 39	Right Return 47	Not Used 55	Left Slingshot 63
8 WHT-GRY 1J10-1	High Score Reset 8	Big Bucks 16	Not Used 24	Prize Letter P in TRIP 32	Not Used 40	Right Outlane 48	Not Used 56	Right Slingshot 64

SWITCHES

Note: Switch #16 is located under the playfield, on the Bottom Ramp.

Item	Part No.	Description
1	20-6502-A	Plumb Bob Tilt
2		Not Used
3	SW-1A-126	Credit Button
4	27-1092	Right Coin Sw.
5	Not used	Center Coin Sw.
6	27-1092	Left Coin Sw.
7	27-1066	Slam Tilt
8	27-1008	High Score Reset
9		Not Used
10	A-10417	Outhole
11	5647-12073-00	Trough 1, Right
12	5647-9957-00	Trough 2, Left
13		Not Used
14	A-11619	Shooter Lane
15		Not Used
16	A-12238	Big Bucks
17	A-12688	Top Lanes Left
18	A-12688	Top Lanes Mid.
19	A-12688	Top Lanes Right
20	A-12010	Right Ramp
21	A-12792	Ball Popper
22		Not Used
23	A-12688	Left Lockup
24		Not Used
25	A-12239	Easy Spin
26	A-12239	Center Ramp
27	B-11696-4	T (in TV)
28	B-11696-4	V (in TV)
29	B-11696-1	T (in Trip)
30	B-11696-1	R (in Trip)
31	B-11696-1	I (in Trip)
32	B-11696-1	P (in Trip)
33	B-11696-2	T (in Truck)
34	B-11696-2	R (in Truck)
35	B-11696-2	U (in Truck)
36	B-11696-2	C (in Truck)
37	B-11696-2	K (in Truck)
38		Not Used
39	p/o C-13312-4	Car Target
40		Not Used
41	A-13401	Spin Wheel
42	A-12010	Right Spinner
43	A-13304	Spot Letter
44		Not Used
45	A-12688	Left Outlane
46	A-12688	Left Return Lane
47	A-12688	Right Return Lane
48	A-12688	Right Outlane
49		Not Used
50		Not Used
51		Not Used
52		Not Used
53		Not Used
54		Not Used

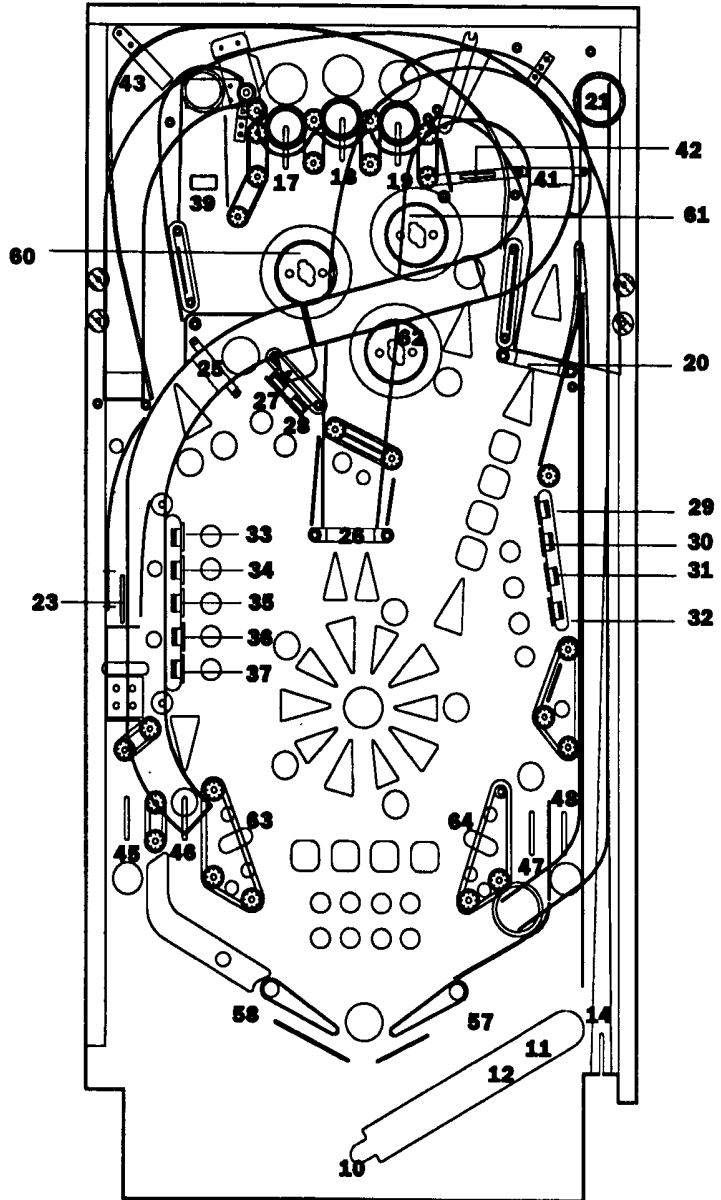

55		Not Used
56		Not Used
57	03-7811 (E.O.S.)	Right Flipper
	A-9990 (Cabinet)	
58	03-7811 (E.O.S.)	Left Flipper
	A-9990 (Cabinet)	
59		Not Used
60	SW-11A-37	Left Jet Bumper
61	SW-11A-37	Right Jet Bumper
62	SW-11A-37	Bottom Jet Bumper
63	SW-1A-114 (Kick)	Left Slingshot
	SW-1A-120 (Score)	
64	SW-1A-114 (Kick)	Right Slingshot
	SW-1A-129 (Score)	

GAME SHOW

Solenoid Table

Sol. No.	Function	Solenoid Type	Wire 1 Color	Connections		Driver Trnstr	Solenoid Part Number	
				CPU Bd	Playfield/Cabinet		Flashlamp Type	d= Display Bd; p=Playfield
01A 3	Outhole Kicker	Switched	Vio-Brn }	1P11-1	5J1-9: 5J4-9 (A)	Q33	AE-23-800	
01B 3	Top Cntr Ln/ Insert Teeth Flasher	Switched	Blk-Brn }	(Gry-Brn)	5J5-9 (C)	Q33	#89 Flashlamps	1b/1p
02A 3	Ball Shooter Ln Feeder	Switched	Vio-Red }	1P11-3	5J1-7: 5J4-8 (A)	Q25	AE-23-800	
02B 3	Rt Back Pnl/Insert 3 Mil Flasher	Switched	Blk-Red }	(Gry-Red)	5J5-8 (C)	Q25	#89 Flashlamps	1b/1p
03A 3	Not Used	Switched	Vio-Orn }	1P11-4	5J1-6: 5J4-7 (A)	Q32	Not Used	
03C 3	Left Plyfld/Insert Title Flasher	Switched	Blk-Orn }	(Gry-Orn)	5J5-7(C)	Q32	#89 Flashlamps	1b/1p
04A 3	Not Used	Switched	Vio-Yel }	1P11-5	5J1-5: 5J4-6 (A)	Q24	Not Used	
04C 3	Rt Plyfld/Insert Title Flasher	Switched	Blk-Yel }	(Gry-Yel)	5J5-5 (C)	Q24	#89 Flashlamps	1b/1p
05A 3	Ball Locker	Switched	Vio-Grn }	1P11-6	5J1-4: 5J4-5 (A)	Q31	AE-23-800	
05C 3	Upper Left Flasher	Switched	Blk-Grn }	(Gry-Grn)	5J5-4 (C)	Q31	#89 Flashlamp	1p
06A 3	Not Used	Switched	Vio-Blu }	1P11-7	5J1-3: 5J4-4 (A)	Q23	Not Used	
06C 3	Rt Back Pnl/Insert Wheel Flasher	Switched	Blk-Blu }	(Gry-Blu)	5J5-3 (C)	Q23	#89 Flashlamps	1b/1p
07A 3	Knocker	Switched	Vio-Blk }	1P11-8	5J1-2: 5J4-2 (A)	Q30	AE-23-800	
07C 3	Applause Flasher	Switched	Blk-Vio }	(Gry-Vio)	5J5-2 (C)	Q30	#906 Flashlamps	2b
08A 3	Car Drop Target	Switched	Vio-Gry }	1P11-9	5J1-1: 5J4-1 (A)	Q22	AE-23-800	
08C 3	Applause Flasher	Switched	Blk-Gry }	(Gry-Blk)	5J5-1 (C)	Q22	#906 Flashlamps	2b
9	Plyfld G.I. Relay	Controlled	Brn-Blk	1P12-1	5J2-9: 5J6-9: 2J4-3	Q17	5580-09555-01	4a
10	Top Ramp Gate	Controlled	Brn-Red	1P12-2	5J2-8: 5J6-8: 2J4-5	Q9	SM2-35-4000	
11	Center Ramp Flasher	Controlled	Brn-Orn	1P12-4	5J2-6: 5J6-7:	Q16	#89 Flashlamp	1p
12	A/C Select Relay	Controlled	Brn-Yel	1P12-5	2J4-6	Q8	5580-09555-01	5
13	Bell	Controlled	Brn-Grn	1P12-6	5J2-5	Q15	SM-26-600	
14	Ball Popper	Controlled	Brn-Blu	1P12-7	5J2-4: 5J6-5	Q7	AE-23-800	
15	Backbox G.I. Relay	Controlled	Brn-Vio	1P12-8	5J2-4: 5J6-3	Q14	5580-09555-01	4a
16	Insert Teeth/Title Flasher	Controlled	Brn-Gry	1P12-9	5J2-2: 5J6-2	Q6	#89 Flashlamps	4b
		Controlled			5J2-1: 5J6-1			
17	Left Jet Bumper	Special #1	Blu-Brn	1P19-7	5J3-7: 5J7-7	Q75	AE-23-800	
18	Left Kicker	Special #2	Blu-Red	1P19-4	5J3-6: 5J7-6	Q71	AE-26-1500	
19	Right Jet Bumper	Special #3	Blu-Orn	1P19-3	5J3-3: 5J7-3	Q73	AE-23-800	
20	Right Kicker	Special #4	Blu-Yel	1P19-6	5J3-4: 5J7-5	Q69	AE-23-1500	
21	Bottom Jet Bumper	Special #5	Blu-Grn	1P19-8	5J3-2: 5J7-2	Q77	AE-23-800	
22	Not Used	Special #6	Blu-Blk	1P19-9	5J3-1: 5J7-1	Q79	Not Used	
-	<u>Right Flipper</u>	-	Orn-Vio 2	1P19-1	2J5-5: 2J10-7	-		
	Lower Right Flipper		[Blu-Vio]		[2J10-1: 2J8-15]		FL11630/ 50VDC	
-	<u>Left Flipper</u>	-	Orn-Gry 2	1P19-2	2J5-4: 2J10-8	-		
	Lower Left Flipper		[Blu-Gry]		[2J10-2: 2J8-4]		FL11630/ 50VDC	

Notes 1. Wire colors, except flipper Orn- Vio and Orn-Gry are ground connections (to terminal with unbanded end of diode). Flipper Orn-Vio and Orn-Gry wires connect from CPU Board to flipper switch. 2. Flipper connections shown in braces are from flipper switch to flipper coil. 3. "A" circuits are pulsed, when Sol. 12 is de-energized; "C" circuits are pulsed, with Sol. 12 energized. Wire colors in brackets are those from respective A and C terminals corresponding to the J1-terminal connection listed for the Aux Power Driver Bd. which controls the device pulsing by Sol. 12. 4. Relay is mounted on Relay bd. (4a) C-11998-1; (4b) C-11902-1. 5. Relay mounted on Aux. Power Driver Bd., D-12247.

SOLENOIDS

Item	Part No.	Description
01A	AE-23-800	Outhole
01C	#89 Flashlamp	Top Cntr Ln/Teeth Flasher
02A	AE-23-800	Ball Shooter Lane Feeder
02C	#89 Flashlamp	Rt. Back Pnl/3 Mil. Flasher
03A		Not Used
03C	#89 Flashlamp	Left Plyfld/Title Flasher
04A		Not Used
04C	#89 Flashlamp	Rt. Plyfld/ Title Flasher
05A	AE-23-800	Ball Locker
05C	#89 Flashlamp	Upper Left Flasher
06A		Not Used
06C	#89 Flashlamp	Rt. Back Pnl/ Wheel Flasher
07A	AE-23-800	Knocker
07C	#906 Flashlamp	Applause Flasher
08A	AE-23-800	Car Drop Target
08C	#906 Flashlamp	Applause Flasher
9	5580-09555-01	Playfield G.I. Relay
10	SM2-35-4000	Top Ramp Gate
11	#89 Flashlamp	Center Ramp Flasher
12	5580-09555-01	A/C Select Relay
13	SM-26-600	Bell
14	AE-23-800	Ball Popper
15	5580-09555-01	Backbox G.I. Relay
16	#89 Flashlamp	Teeth Flasher
17	AE-23-800	Left Jet Bumper
18	AE-26-1500	Left Slingshot
19	AE-23-800	Right Jet Bumper
20	AE-26-1500	Right Slingshot
21	AE-23-800	Bottom Jet Bumper
22		Not Used
	FL11630	Left & Right Flippers

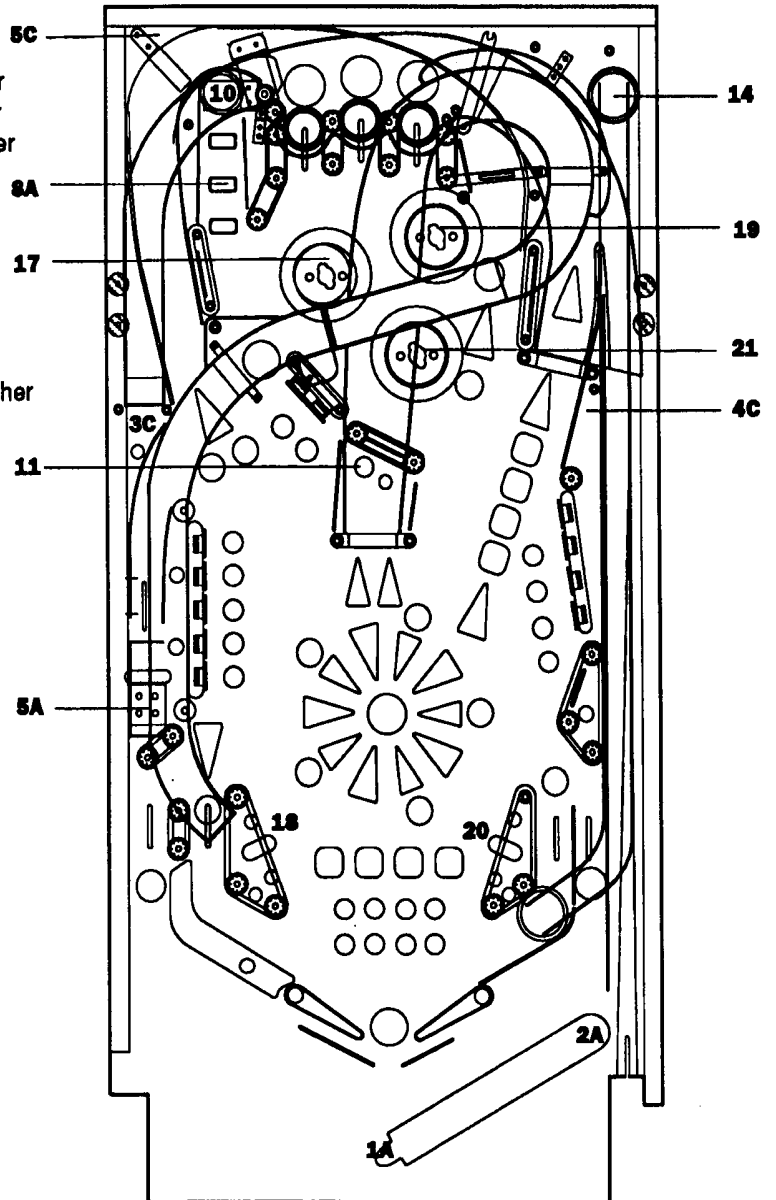

PLAYFIELD PARTS

Major Assemblies

Item	Part No.	Description
1	12-6468	Rebound Wire
2	C-11626-R-3	Flipper
3	B-8039-2	Outhole
4	A-11619	Shooter Lane Switch Assembly
5	C-13297	Ball Guide
6	A-13405	Wire Ball Guide
7	B-11203-R-1	Kicker (Slingshot)
8	23-6305	Rubber Ring
9	12-6466-12	Ball Guide
10	12-6466-6A	Ball Guide
11	23-6305	Rubber Ring
12	B-11696-1	Target
13	B-13293	Ball Guide
14	A-13309	Switch Gate Assembly
15	12-6466-10	Ball Guide
16	23-6304	Rubber Ring
17	A-13303	Switch Gate Assembly
18	B-13298	Spinner
19	12-6466-7	Ball Guide
20	A-13401	Ball Gate
21	D-13296	Ball Guide Assembly
22	23-6300	Rubber Ring
23	03-8372-9	Red Light Hood
24	23-6302	Rubber Ring
25	A-13291	Ball Guide
26	A-13290	Ball Guide
27	C-13295	Ball Guide
28	A-13305	Rebound Gate Assembly
29	12-6466-4A	Ball Guide
30	23-6304	Rubber Ring
31	B-9414	Jet Bumper
32	B-11696-4	Target
33	23-6303	Rubber Ring
34	12-6891	Ball Guide
35	A-13301	Switch Gate Assembly
36	12-6466-7	Ball Guide
37	23-6303	Rubber Ring
38	12-6466-6	Ball Guide
39	B-13294	Ball Guide
40	B-13292	Ball Guide
41	B-11696-2	Target
42	C-13386	Multi-ball Kicker (Ball Locker)
43	23-6301	Rubber Ring
44	23-6300	Rubber Ring
45	B-11203-L-1	Kicker (Slingshot)
46	B-13259	Ball Guide
47	C-11626-L-3	Flipper
48	12-6468	Rebound Wire

Rubber Parts

Item	Part No.	Description
1	23-6303	Rubber Ring 1-1/4"
2	23-6313-1	Rubber Grommet
3	23-6327	Ball Shooter Tip
4	23-6420	Rubber Grommet
5	23-6519-4	Flipper Red Rubber Ring
6	23-6534	Glass Protector
7	23-6539-9	Edge Protector
8	23-6535	Rubber Bumper
9	23-6577	Rubber Bumper Plug
10	23-6622	Foam Tape
11	23-6626	Rubber Grommet

Parts Under Bottom Arch

Item	Part No.	Description
1	B-8623	Upper Trough Baffle Assy
2	B-12445-1	Shooter Assembly
3	01-5575	Bottom Arch Mtg. Bracket
4	12-6542	Baffle Wireform
5	C-8235	Lower Trough Baffle Assy
6	A-8645	Switch Wire & Brkt Assy
7	A-11680	Right Ball Trough Switch

PLAYFIELD PART LOCATIONS

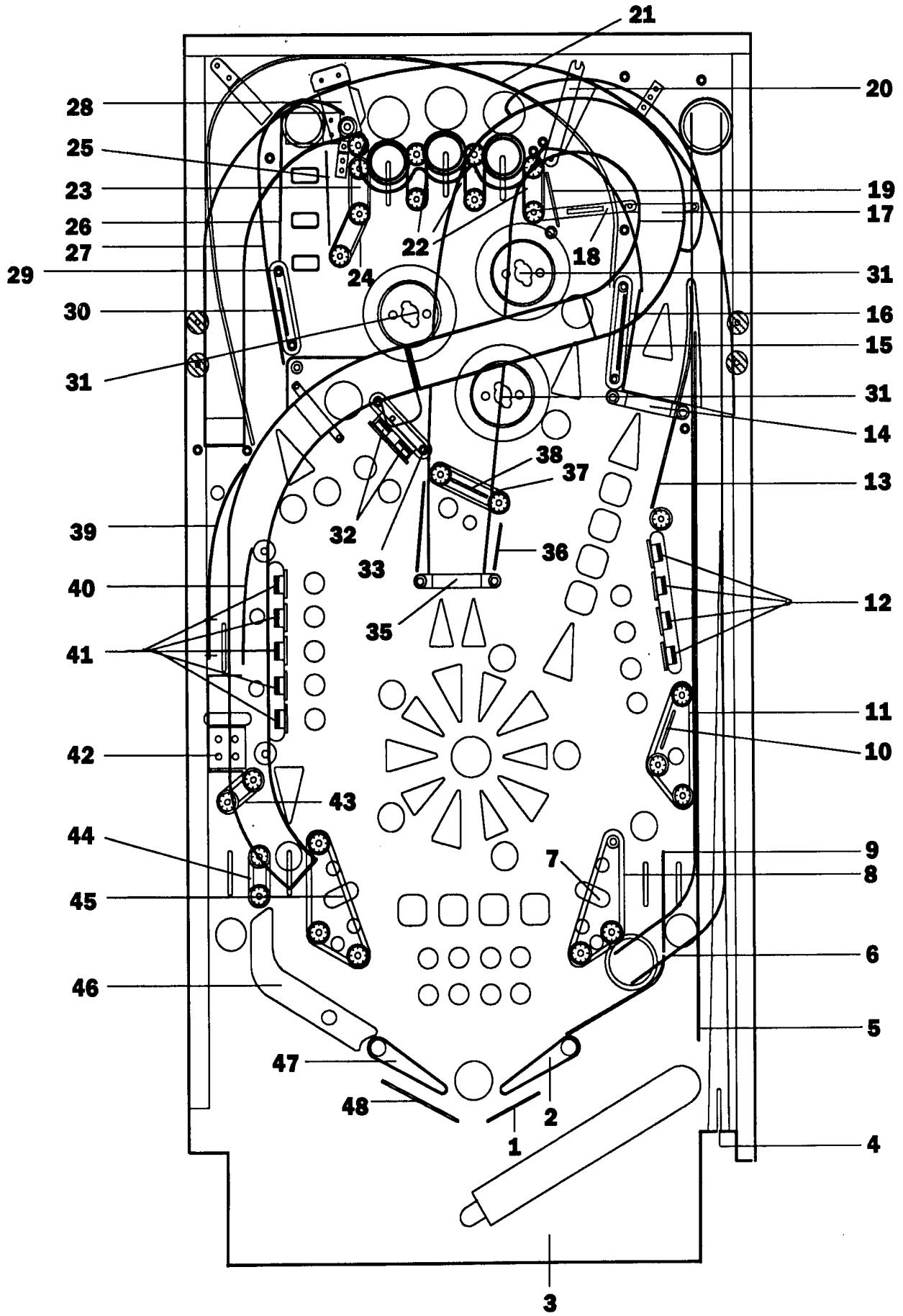

**Extra Ball, 2 Million, Spot Letter
Lamp Assembly**
p/n C-13366

Part No.	Description
5768-12588-00	Bare PCB
24-8767	TwistLamp Socket
24-8768	Bulb #555, 6.3V
5070-09054-00	Diode, 1N4004
5791-10871-05	Header, 5 pin, Sq

Truck Lamp Assembly
p/n C-13365

Part No.	Description
5768-12587-00	Bare PCB
24-8767	Twist Lamp Socket
24-8768	Bulb, #555, 6.3V
5070-09054-00	Diode, 1N4004
5791-10871-07	Header, 7 pin, Sq

Bonus Lamp Assembly
p/n C-13352

Part No.	Description
5768-12582-00	Bare PCB
24-8767	Twist Lamp Socket
24-8768	Bulb, #555, 6.3V
5070-09054-00	Diode, 1N4004
5791-10871-11	Header, 11 pin, Sq

Applause Lamp Assembly
p/n C-13354

Part No.	Description
5768-12581-00	Bare PCB
24-8803	Twist Lamp Socket
24-8802	Bulb, #906, 13V
5070-09054-00	Diode, 1N4004
5791-10871-05	Header, 5 pin, Sq

Grand Prize Lamp Assembly
p/n C-13364

Part No.	Description
5768-12586-00	Bare PCB
24-8767	Twist Lamp Socket
24-8768	Bulb, #555, 6.3V
5070-09054-00	Diode, 1N4004
5791-10871-07	Header, 7 pin, Sq

Trip Lamp Assembly
p/n C-13368

Part No.	Description
5768-12590-00	Bare PCB
24-8767	Twist Lamp Socket
24-8768	Bulb, #555, 6.3V
5070-09054-00	Diode, 1N4004
5791-10871-06	Header, 6 pin, Sq

Wheel Lamp Assembly
p/n D-13367

Part No.	Description
5768-12589-00	Bare PCB
24-8767	Twist Lamp Socket
24-8768	Bulb, #555, 6.3V
5070-09054-00	Diode, 1N4004
5791-10871-15	Header, 15 pin, Sq
5010-09534-00	0Ω Resistor

Chase Lamp Assembly
p/n C-13353-1

Part No.	Description
5768-12580-00	Bare PCB
24-8804	V-wedge Socket
24-8768	Bulb, #555, 6.3V
5791-10871-06	Header, 6 pin, Sq

Chase Lamp Assembly
p/n C-13353-2

Part No.	Description
5768-12580-00	Bare PCB
24-8804	V-wedge Socket
24-8768	Bulb, #555, 6.3V
5791-10871-06	Header, 6 pin, Sq

Right Ramp Assembly
p/n D-13260

Part No.	Description
A-13305	Rebound Gate Assembly
A-13401	Ball Gate Shooter Assembly
01-9458	Ramp Flap
01-9459	Ramp Flap
01-9460	Stop Bracket
01-9532	Protect Bracket
02-4321	Bumper Post
03-8171-9	Red Dome
03-8172-13	Clear Dome
03-8354	Right Ramp
07-6688-17N	Rivet 5-32 x .218
23-6535	Rubber Bumper
24-8802	Bulb, #906, 13V
24-8812	Light Socket
4006-01027-06	M.S. 6-32 x 3/8 P-RWH
4406-01128-00	Nut 6-32 KEPS
4700-00003-00	F.W. .125 x .281 x .032

Left Ramp Assembly
p/n D-13264

Part No.	Description
A-12239	Sub-mini Switch Assembly
A-13303	Gate Switch Assembly
H-13329	Easy Spin Cable
01-8774	Switch Bracket
01-9461	Stop Bracket
03-8356	Left Ramp
07-6688-17N	Rivet 5/32 x .218
07-6688-19N	Rivet 7/32 x .218
4002-01005-06	M.S. 2-56 x 3/8 P-PH
4006-01027-06	M.S. 6-32 x 3/8 P-RWH
4406-01128-00	Nut 6-32 KEPS
4700-00003-00	F.W. .125 x .281 x .032
4701-00024-00	L.W. #2 Split

Center Ramp Assembly
p/n D-13261

Part No.	Description
A-12239	Sub-mini Switch Assembly
A-13303	Gate Switch Assembly
H-13328	Spin Wheel Cable
01-8774	Switch Bracket
01-9462	Ramp Flap
03-8355	Center Ramp
07-6688-17N	Rivet 5/32 x .218
4002-01005-06	M.S. 2-56 x 3/8 P-PH
4006-01027-06	M.S. 6-32 x 3/8 P-RWH
4406-01128-00	Nut 6-32 KEPS
4700-00003-00	F.W. .125 x .281 x .032
4701-00024-00	L.W. #2 Split

Bottom Ramp Assembly
p/n D-13285

Part No.	Description
A-12238	Sub-mini Switch
01-8774	Switch Bracket
03-8357	Bottom Ramp
07-6688-19N	Rivet 7-32 x .218
4002-01005-06	M.S. 2-56 x 3/8 P-PH
4701-00024-00	L.W #2 Split

Backbox Parts List

Part No.	Description
A-12497	Upper Hinge Assembly
A-12498	Lower Hinge Assembly
A-12948	3 Terminal Strip & Resistor Assembly
B-10686-1	Knocker & Bracket Assy
C-11602-1	Cap & Cable Assembly
C-11908-1	Relay Assembly
C-13286	Sound Overlay Lamp Assy
D-11581-2003	Audio Board Assembly
D-11883-2003	CPU Board Assembly
D-12246	Power Supply Assembly
D-12247-566	Aux Power Driver Board Assembly
D-12313-2003	Master Interconnect Board Assembly
D-12502-1	Bally R-Display
D-12706	Bally Left Display
D-13323	Speaker Panel Assembly
5555-1206-00	4" Piezo Speaker
5555-12469	4 Round Speaker
01-6645	Venting Screen
01-6655	Insert Latch
01-8397	Trunk Latch

Cable List

Part No.	Description
H-10978	A.C. Cable
H-11037	Sound Interconnect Cable
H-11834	18V Rectifier Cable
H-11835	Knocker Cable
H-12190-2003	Main Backbox Cable
H-12192-2003	Cabinet Cable
H-12196-553	Secondary Cable
H-12199	Lamp Interconnect Cable
H-12200	Switch Interconnect Cable
H-12299-2003	Logic/Power Speaker Cable
H-12775	Speaker Panel Cable
H-12776	Main Display Cable
H-13324	Playfield Switch Cable
H-13325	Playfield Lamp Cable
H-13326	Playfield Solenoid Cable
H-13327	Flash Lamp Cable
H-13328	Spin Wheel Cable
H-13329	Easy Spin Cable
H-13330	Spot Letter Cable
H-13331	Insert Cable

Miscellaneous Parts List

Part No.	Description
A-11-2003-PL	Playfield & Insert Assy
A-11831-2003	Back Panel w/ Inserts
A-8552-2003	Backglass Assembly
A-8567-2003	Cash Box Assembly
C-10843-1	Bally Metal Leg Assembly
C-11026	Line Filter Assembly
01-8320	Line Filter Chassis
01-8419	Playfield Holdown
03-7960-2003	Playfield Mylar
03-7960-2003-1	Playfield Mylar
03-8228-1	Glass Edge Channel
03-8228-2	Glass Top Channel
03-8229-1	Glass Lift Channel
09-8803	Coin Rejector
11-831-2003	Back Panel Assembly
20-6500	Steel Ball 1-1/16
20-9620	Key-Long Arm
20-9637	Lock & Cam
2003-BB	Game Show Backbox
2003-IN	Game Show Insert Panel
24-6549	# 44 Bulb
24-8768	#555 Bulb
24-8802	#906 Bulb
31-1006-2003	Playfield Plastic
31-1008-2003	Screened Bottom Arch
31-1357-2003	Screened Backglass
31-1475-2003	Screened Back Panel
5102-10310-00	Line Filter

UNIQUE PARTS

Part No.	Description	Part No.	Description
A-11-831-2003	Back Panel w/ Inserts	03-8354	Right Ramp
A-13381	B/G Armature Assembly	03-8355	Center Ramp
A-13401	Ball Gate Shooter Assy	03-8356	Left Ramp
		03-8357	Bottom Ramp
B-13298	Spinner Assembly	03-8372-9	Single Red Lamp Hood
B-13307	Ball Popper Bracket Assy	03-8373-9	Double Red Lamp Hood
B-13380	Top Ramp Gate		
B-13403	Switch Bracket Assembly	10-413	Extension Spring
C-13352	Bonus Lamp Assembly	11-2003-PL	Wood Playfield
C-13353-1	Chase Lamp Assembly	11-831-2003	Back Panel Assembly
C-13353-2	Chase Lamp Assembly	11-930-A	Wood Rail L=36
C-13364	Grand Prize Lamp Assy	11-930-B	Wood Rail L=38-1/8
C-13365	Truck Lamp Assembly		
C-13366	Extra Ball, 2 Million, Spot Letter Lamp Assembly	12-6881	Wire Ramp
C-13368	Trip Lamp Assembly	16-2003-1	Instruction Card
C-13386	Ball Locker Assembly	16-2003-101	Instruction Manual
		16-2003-103	Operating Handbook
D-13260	Right Ramp Assembly		
D-13261	Center Ramp Assembly	31-1002-2003	Screened Playfield
D-13262	Left Ramp Assembly	31-1008-2003	Screened Bottom Arch
D-13285	Bottom Ramp Assembly	31-1009-2003	Screened Shooter Gauge
D-13306	Ball Popper w/ Extension	31-1357-2003	Screened Backglass
D-13308	Back Panel Assembly	31-1475-2003	Screened Back Panel
D-13367	Wheel Lamp Assembly		
H-13324	Playfield Switch Cable		
H-13325	Playfield Lamp Cable		
H-13326	Playfield Solenoid Cable		
H-13327	Flash Lamp Cable		
H-13328	Spin Wheel Cable		
H-13329	Easy Spin Cable		
H-13330	Spot Letter Cable		
01-9458	Ramp Flap		
01-9459	Ramp Flap		
01-9460	Stop Bracket		
01-9461	Stop Bracket		
01-9462	Ramp Flap		
01-9463	Bottom Ramp Bracket		
01-9464	Stop Bracket		
01-9474	Spinner Bracket		
01-9477	Gate Leg Actuator Bracket		
01-9482	Ball Popper Extension Bracket		
01-9542	Ball Ramp Deflector		
03-7960-2003-1	Playfield Mylar		
03-7960-2003-2	Playfield Mylar		

**Pinout Table for Display Glasses used on
Bally L-Display Board (D-12706)
and R-Display Board (D-12502)**

(Also applicable to Williams Master Display, D-12232-1 and D-12232-2)

Board Pin #	Glass Pin #	Signal/ Function	Board Pin #	Glass Pin #	Signal/ Function	Board Pin #	Glass Pin #	Signal/ Function
1	1	Not connected	25	31	Strobe 11	36	61	Strobe 6
2	2	Segment A		32	cut		62	cut
3	3	Segment J	26	33	Strobe 11	37	63	Strobe 5
4	4	Segment B		34	cut		64	cut
5	5	Strobe 16		35	cut	38	65	Strobe 5
6	6	Segment K		36	cut		66	cut
7	7	Strobe 16	27	37	Strobe 10		67	cut
8	8	Segment H		38	cut		68	cut
9	9	Segment F	28	39	Strobe 10	39	69	Strobe 4
10	10	Segment M		40	cut		70	cut
11	11	Strobe 15	29	41	Strobe 9	40	71	Strobe 4
12	12	Segment C		42	cut		72	cut
13	13	Strobe 15	30	43	Strobe 9		73	cut
14	14	Not connected		44	cut		74	cut
15	15	Strobe 14		45	cut	41	75	Strobe 3
16	16	Dot		46	cut		76	cut
17	17	Strobe 14	31	47	Strobe 8	42	77	Strobe 3
18	18	Segment D		48	cut		78	cut
19	19	Strobe 13	32	49	Strobe 8	43	79	Strobe 2
20	20	Dot		50	cut	44	80	Comma
21	21	Strobe 13		51	cut	45	81	Strobe 2
22	22	Not connected		52	cut	46	82	Segment P
	23	cut	33	53	Strobe 7	47	83	Segment R
	24	cut		54	cut	48	84	Segment E
23	25	Strobe 12	34	55	Strobe 7	49	85	Strobe 1
	26	cut		56	cut	50	86	Segment N
24	27	Strobe 12	35	57	Strobe 6	51	87	Strobe 1
	28	cut		58	cut	52	88	Segment
	29	cut		59	cut	53	89	- 100V dc
	30	cut		60	cut			

S
E
C
T
I
O
N

3

***Reference Diagrams
and
Schematics***

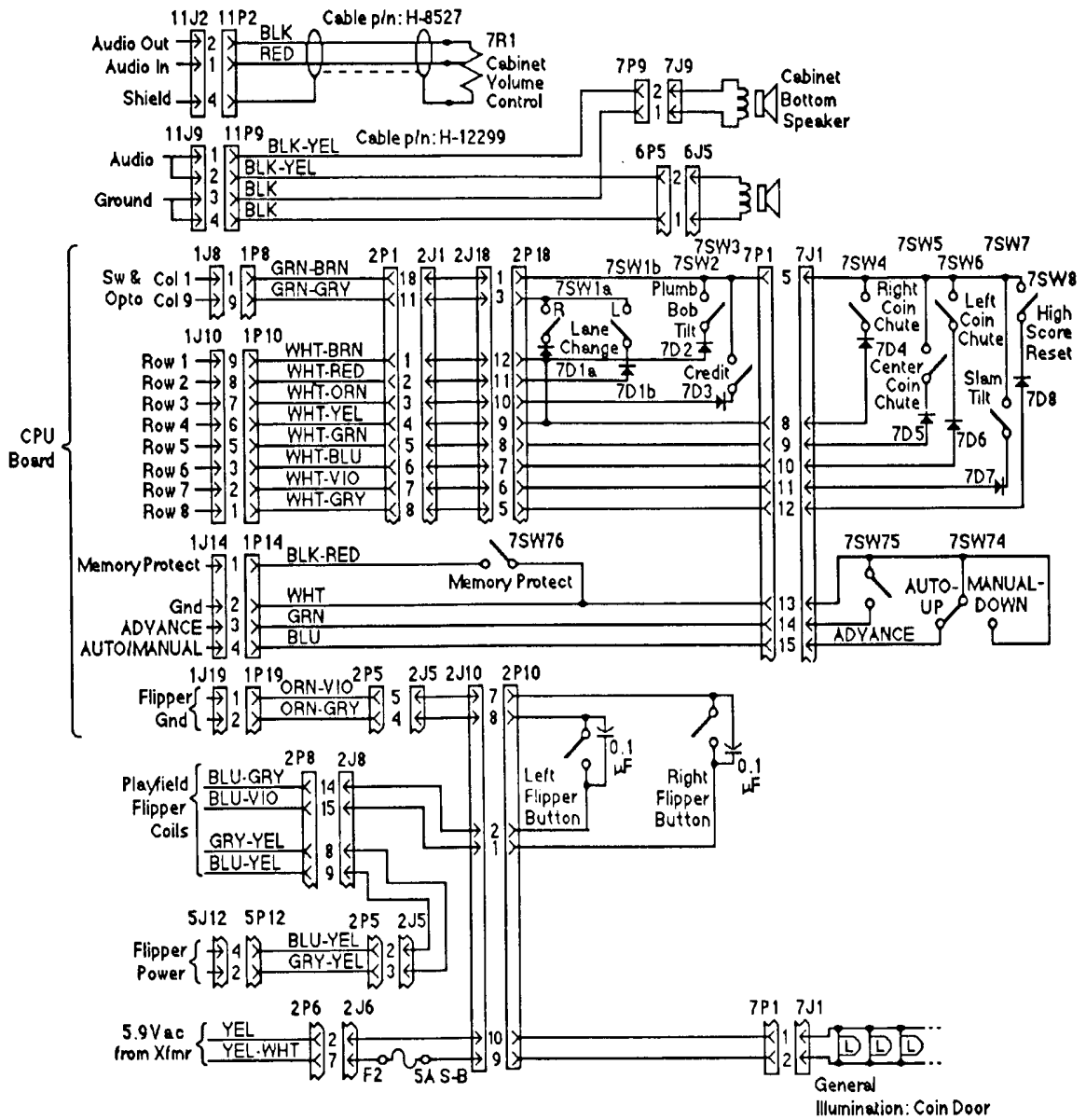

GAME SHOW Cabinet Wiring

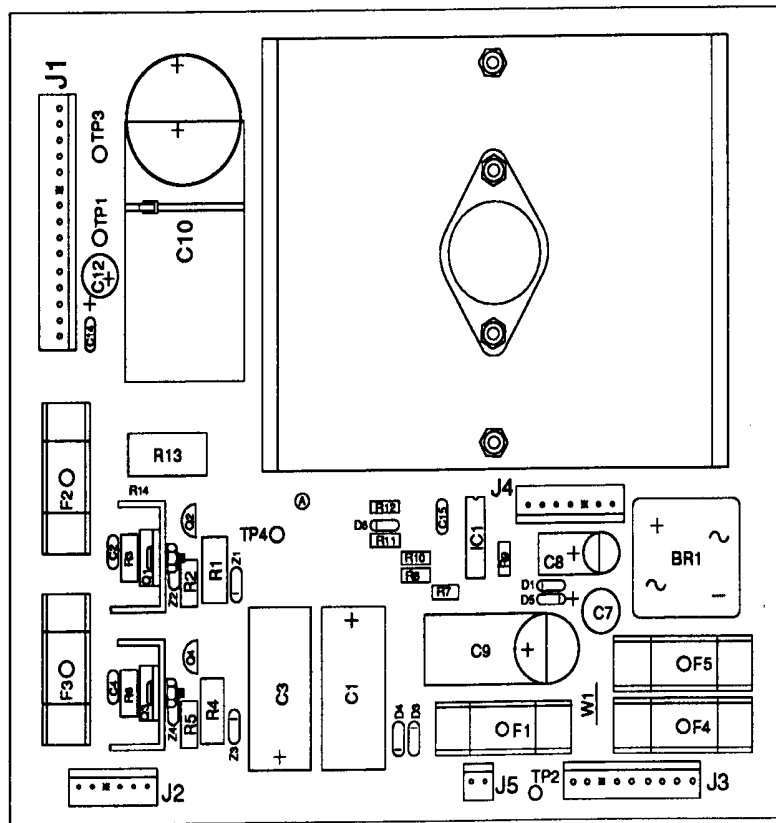

Power Supply Board
p/n D-12246

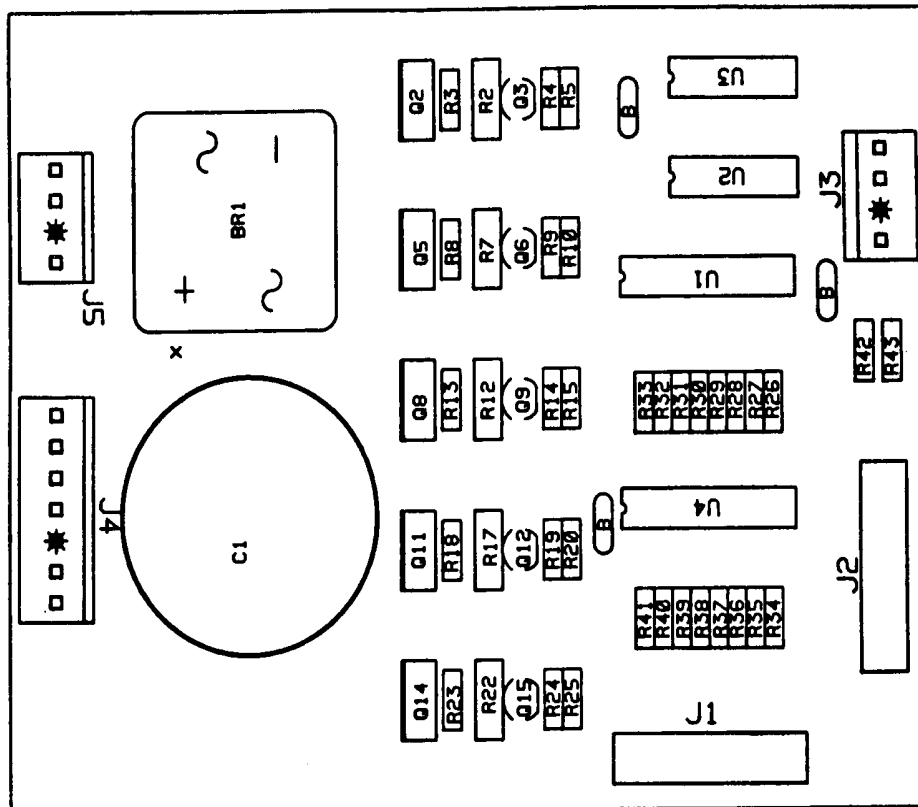

Sound Overlay Lamp Assembly
p/n C-13286

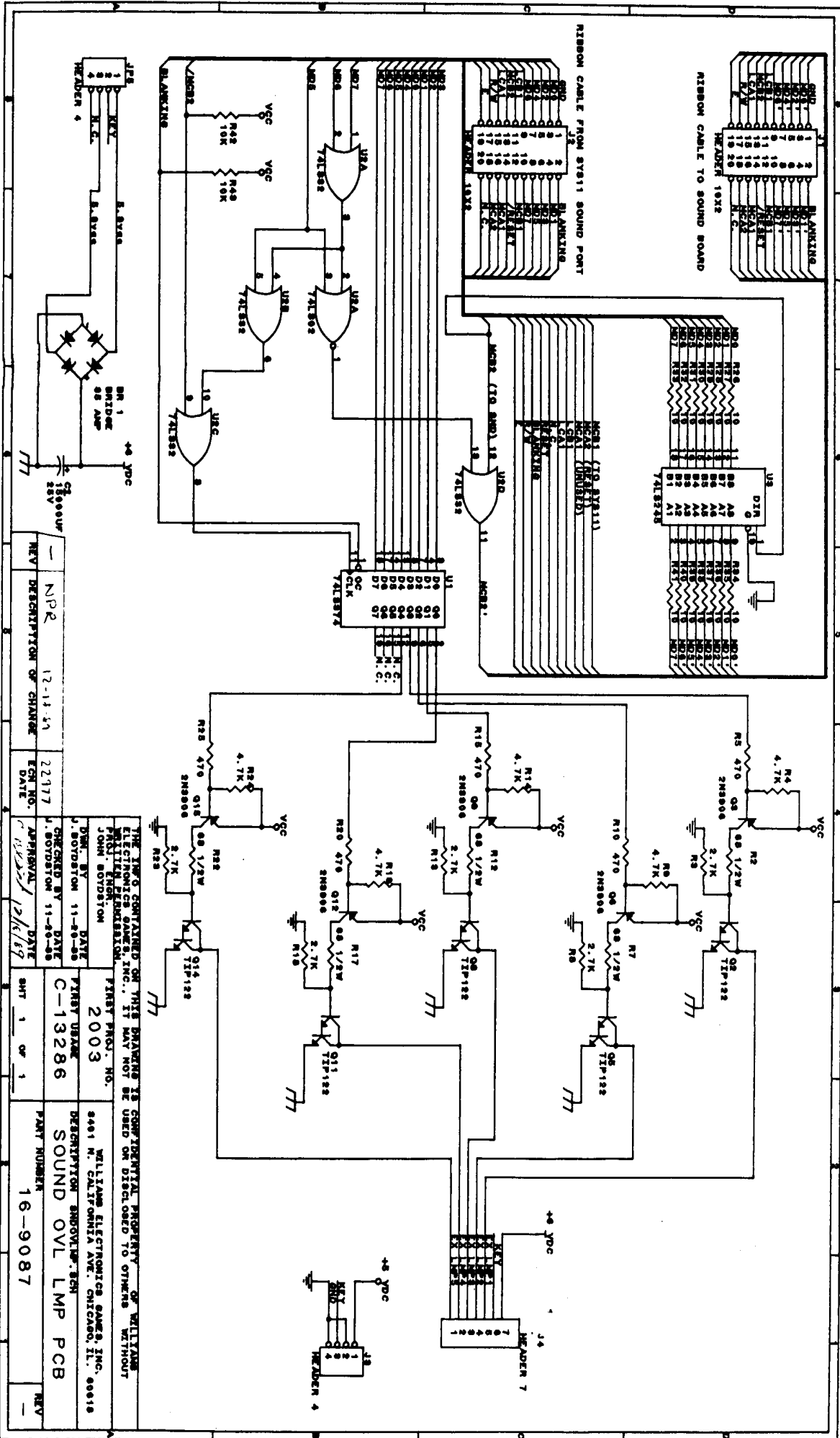

Sound Overlay Lamp Board Schematic 3-4

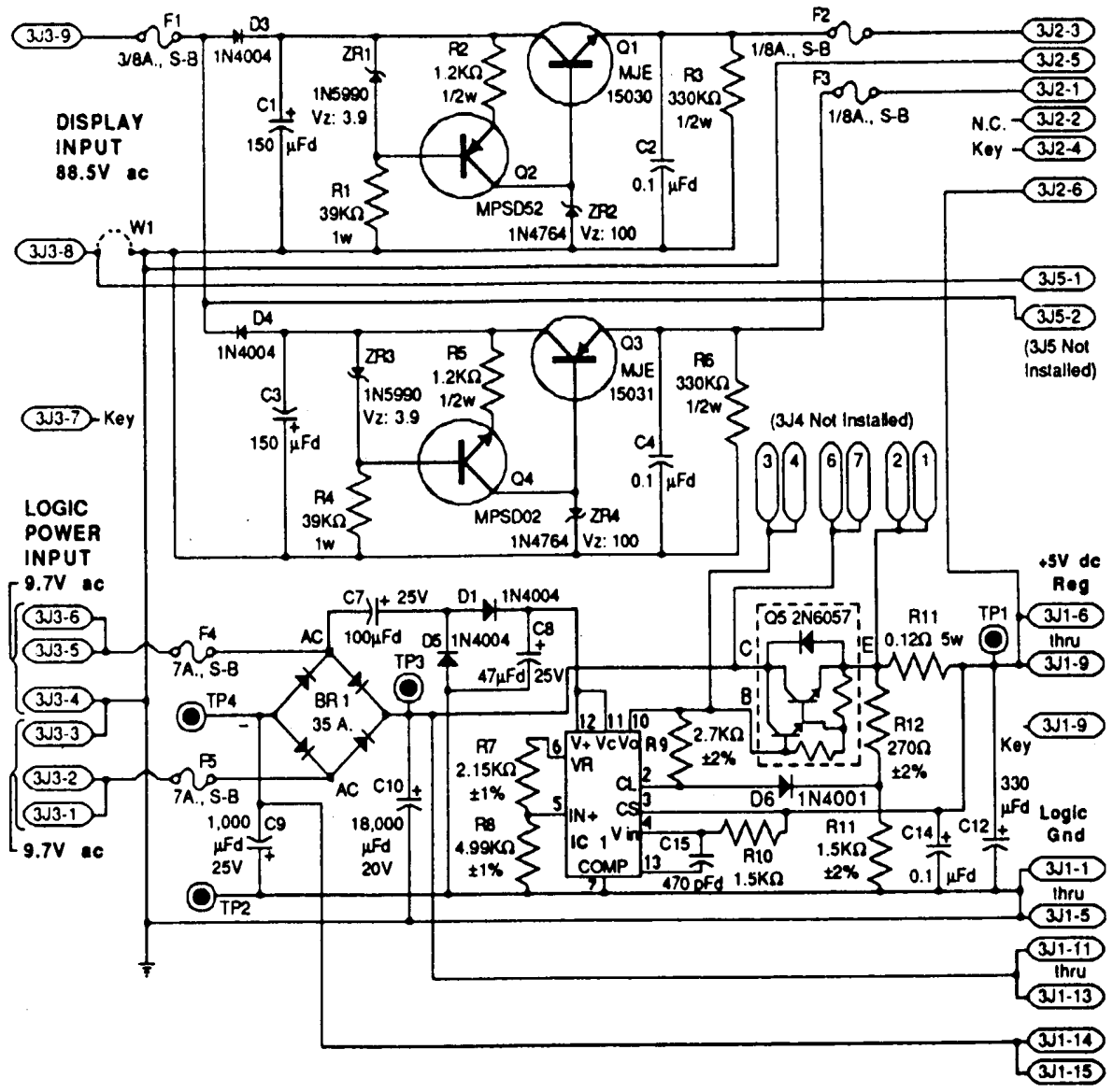

POWER SUPPLY BOARD SCHEMATIC

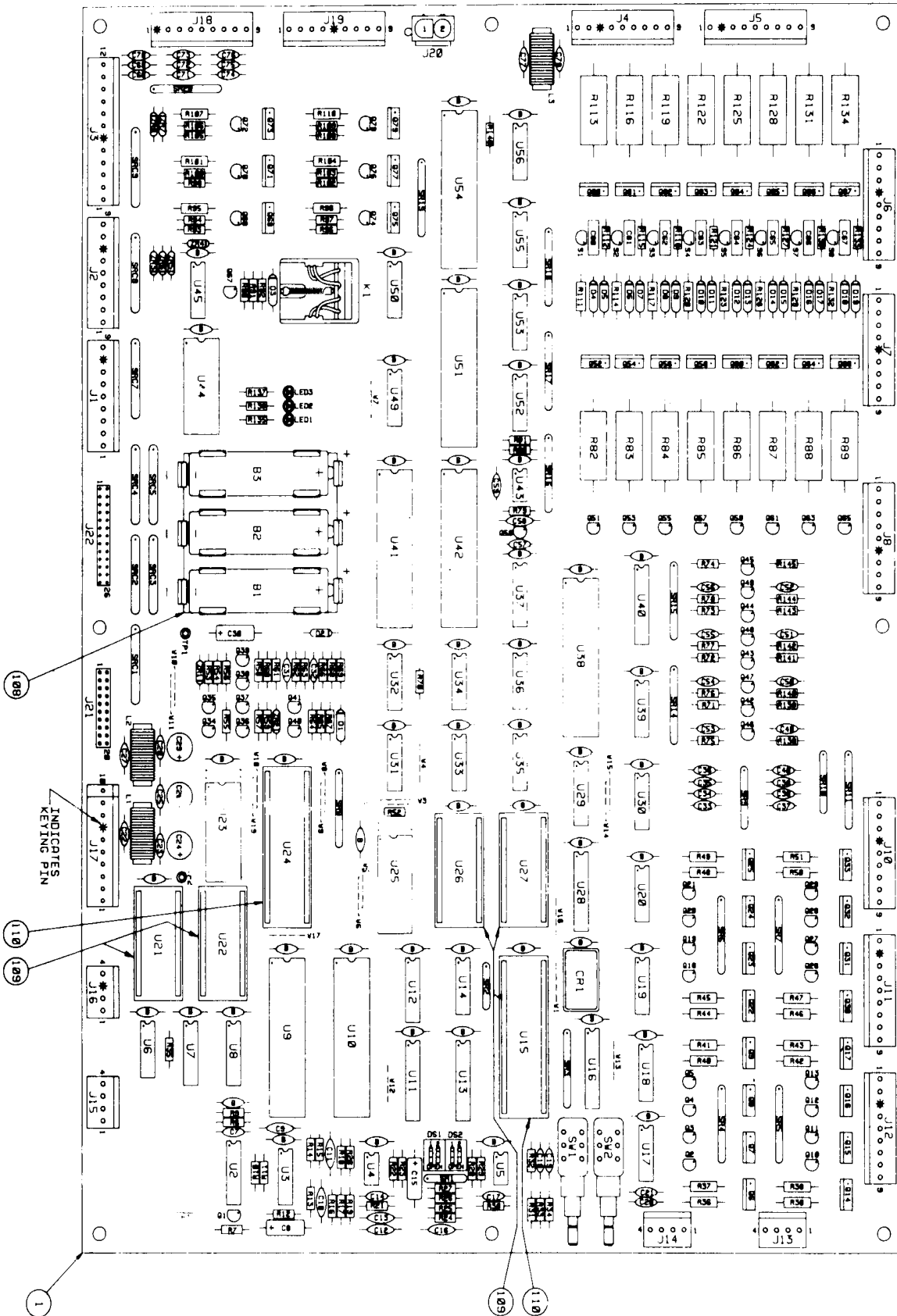

System 11B CPU Board (D-11883)

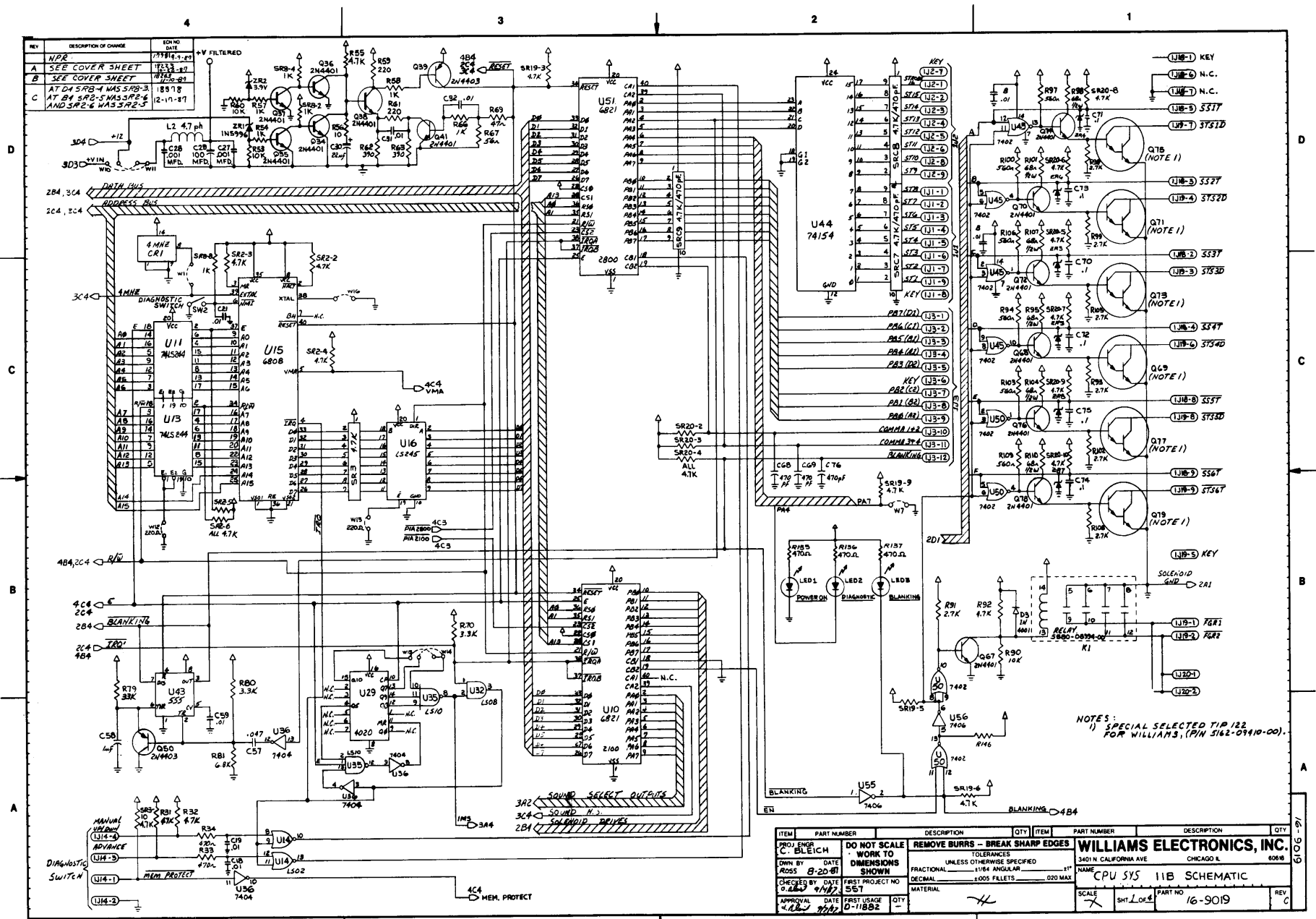

System 11B CPU Schematic (16-9019, Sheet 1 of 4)

REV	DESCRIPTION OF CHANGE	ECN NO	DATE
1	NPR	778	8/27
A	SEE COVER SHEET	182	8/27
B	SEE COVER SHEET	182	10/20
C	RT AT Q77 WAS C7B AND C7B WAS C77	187	11/27
D	R71, R40, R78 WAS 1/5K Q43, THRU Q49 WAS 2.2K 204	190	5-11-88

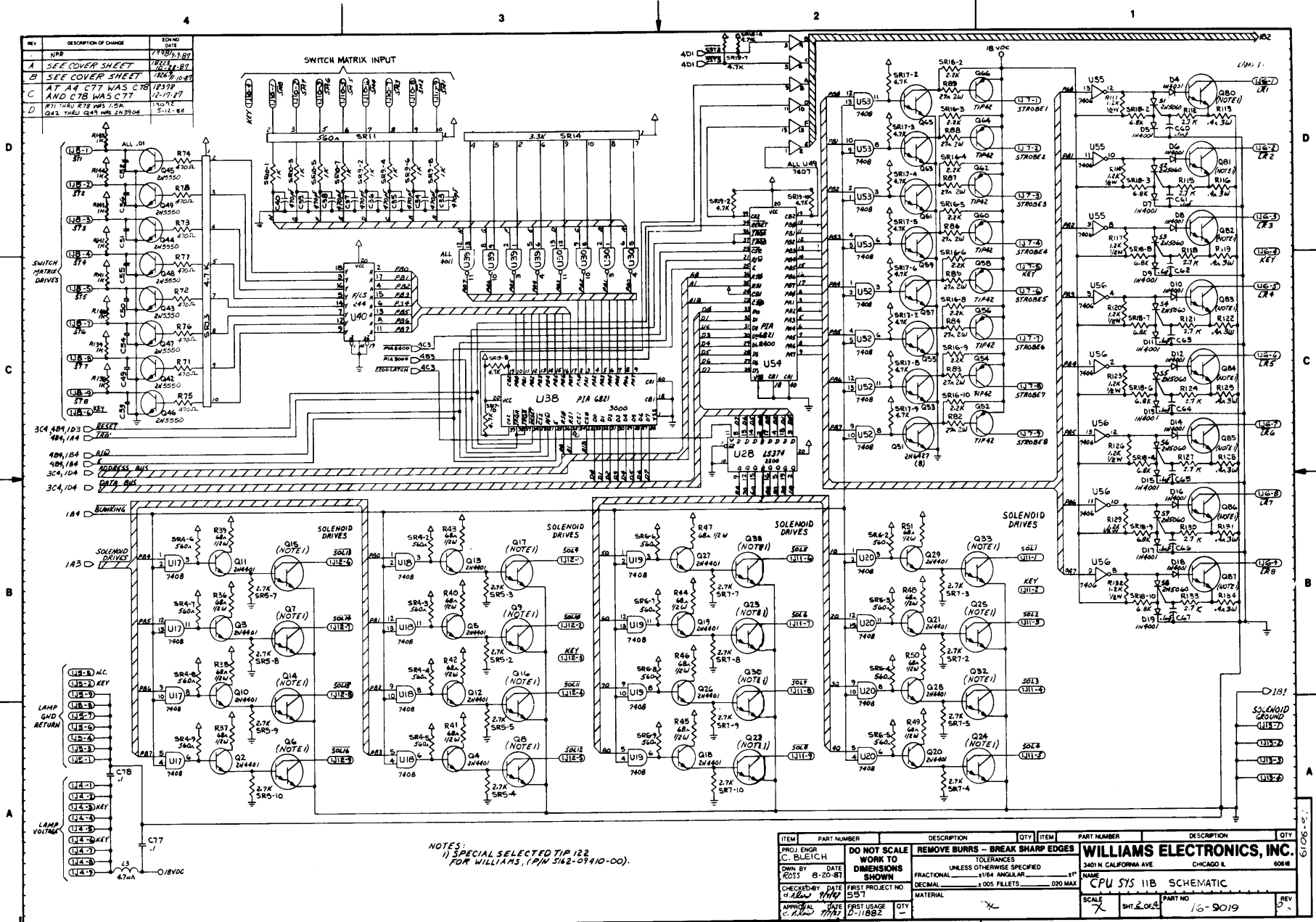

NOTES:
1) SPECIAL SELECTED TIP 122 FOR WILLIAMS, (P/N 542-0940-00).

ITEM	PART NUMBER	DESCRIPTION	QTY	ITEM	PART NUMBER	DESCRIPTION	QTY
PROJ ENGR	C. BLEICH	DO NOT SCALE		REMOVE BURRS - BREAK SHARP EDGES		WILLIAMS ELECTRONICS, INC.	
OWN BY	DATE	TOLERANCES		UNLESS OTHERWISE SPECIFIED		2401 N. CALIFORNIA AVE	60618
REV	8-20-87	FRACTIONAL	1/64 ANGULAR	1"		CHICAGO IL	
CHECKED BY	DATE	DECIMAL	.005 FILLETS	020 MAX		NAME	
10/28/87	11/14/87	MATERIAL				CPU SYS 11B SCHEMATIC	
APPROVAL	DATE	FIRST USAGE				SCALE	
	7/7/87	16-9019				SHT. 2 OF 2	

System 11B CPU Schematic (16-9019, Sheet 2 of 4)

REV	DESCRIPTION OF CHANGE	EDW DATE
	N. P. R.	7/18/72-2-27
A	SEE COVER SHEET	12-13-80
B	SEE COVER SHEET	12-13-80
C	AT C1 3APB-5 WAS 3APB-4 DELETE SOUND SELECT SW & LAYOUT A3	12-11-89

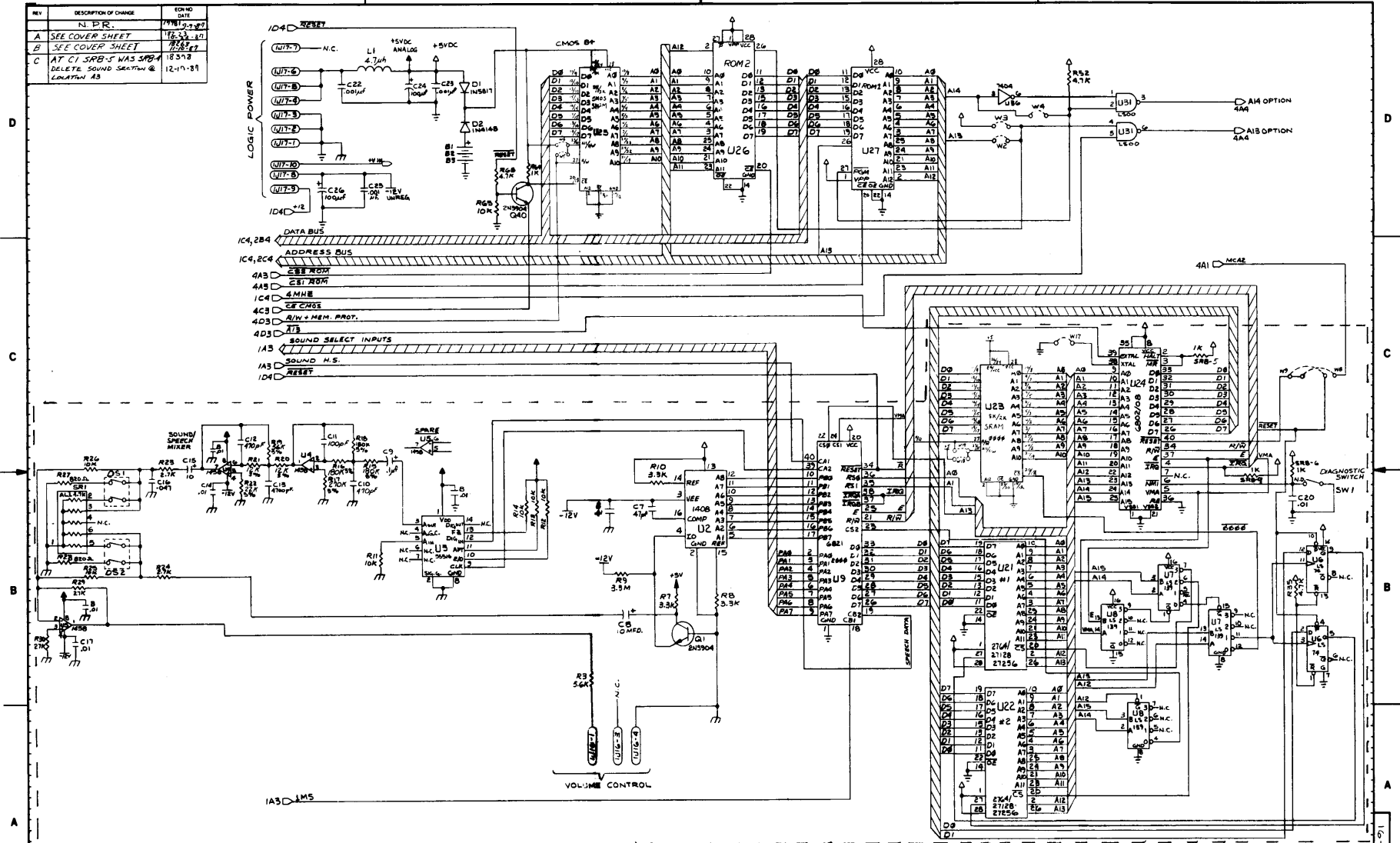

NOTE: GAMES WITH A D-11882-2 SUB-ASSEMBLY
DO NOT USE THESE PARTS.

ITEM	PART NUMBER	DESCRIPTION	QTY	ITEM	PART NUMBER	DESCRIPTION	QTY
PROJ ENGR	C. BLEICH	DO NOT SCALE		REMOVE BURRS - BREAK SHARP EDGES		WILLIAMS ELECTRONICS, INC.	
CHKD BY	ROSS 8-20-87	WORK TO DIMENSIONS SHOWN		TOLERANCES UNLESS OTHERWISE SPECIFIED		3401 N. CALIFORNIA AVE	CHICAGO IL 60618
CHECKED BY	DATE 11/11/89	FIRST PROJECT NO. 557		FRACTIONAL .1164 ANGULAR .11"		NAME CPU SYS 11B SCHEMATIC	
APPROVAL DATE 12/11/89		FIRST USAGE DATE 12-11-89		DECIMAL .005 FILETS .020 MAX		SCALE 1:1	PART NO. 16-9019
				MATERIAL		SHT 2 OF 4	REV C

System 11B CPU Schematic (16-9019, Sheet 3 of 4)

REV	DESCRIPTION OF CHANGE	EDN NO	DATE
	N. P. R.		11-17-87
A	SEE COVER SHEET	16-9019	11-17-87
B	SEE COVER SHEET	16-9019	11-17-87
C	SEE SHEET 1-3	16-9019	11-17-87

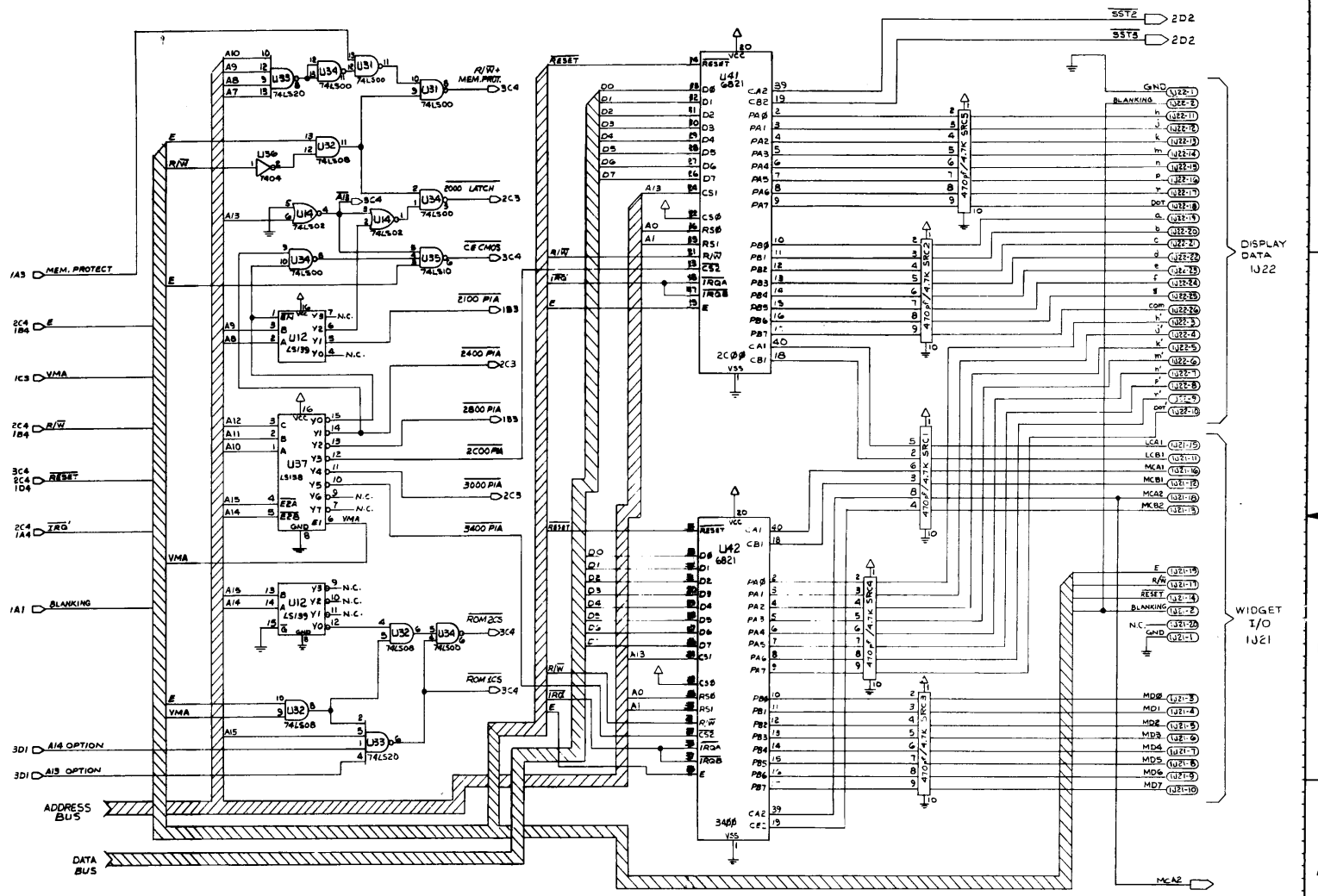

REV	PART NUMBER	DESCRIPTION	QTY	ITEM	PART NUMBER	DESCRIPTION	QTY
1	DO NOT SCALE	WORK TO DIMENSIONS SHOWN			WILLIAMS ELECTRONICS, INC.		
	DO NOT SCALE	REMOVE BURRS - BREAK SHARP EDGES			3401 N. CALIFORNIA AVE CHICAGO IL 60618		
	UNLESS OTHERWISE SPECIFIED	FRACTIONAL _____ 1/64 ANGULAR _____ 1°			NAME CPU SYS 11B SCHEMATIC		
	DECIMAL _____ 0.005 FALLETS _____ 0.020 MAX				SCALE N/S PART NO 16-9019		
	FIRST PROJECT NO 16-9019				REV C		
	DATE 11-17-87						
	FIRST USAGE 16-9019						
	DATE 11-17-87						

System 11B CPU Schematic (16-9019, Sheet 4 of 4)

REV	DESCRIPTION OF CHANGE	ECH NO DATE
—	N. P. R. 5-1-89	21129

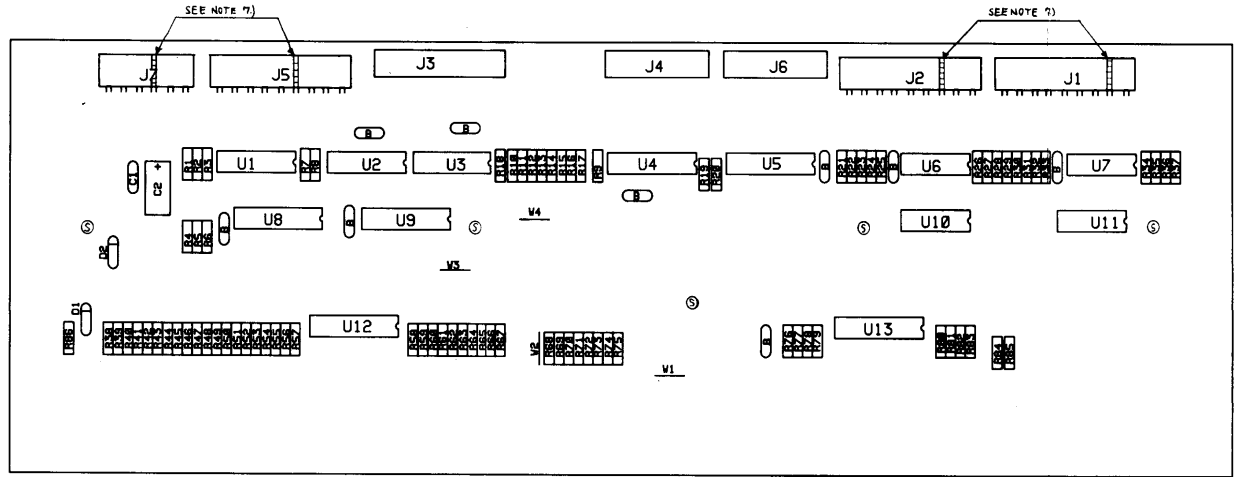

BALLY R-DISPLAY

ITEM	PART NUMBER	PART DESIGNATION	DESCRIPTION	QTY
1	5043-0890-00	B (BYPASS CAP)	CAP. .01MF 50V AX. CR.	8
2	5043-0898-00	C1	CAP. .1MF 50V AX. CR.	1
3	5040-08343-00	C2	CAP. 10MF 25V AX. ELECT.	1
4	5075-09135-00	D1, D2	ZENER 1M4740 10V	2
5	5070-12308-00	DSPT1	DISPLAY, 16-CHARACTER A/W	1
6	5791-10868-09	J1, J2, J5	9 PIN HEADER, R/A. .156	3
7	5791-10851-00	J3	28 PIN HEADER, R/A. .100	1
8	5791-10868-06	J7	6 PIN HEADER, R/A. .156	1
9	5791-09438-00	CHART	20 PIN HEADER, R/A. .100	CHART
10	5010-08773-00	R1-R8, R21-R37	RES. 18K ohm 1/4W	25
11	5010-09162-00	NOTE 1	RES. 100K ohm 1/4W	CHART
12	5010-10258-00	NOTE 2	RES. 1M ohm 1/4W	CHART
13	5010-10927-00	NOTE 3	RES. 8.2K ohm 1/2W	CHART
14	5010-08981-00	NOTE 4	RES. 10K ohm 1/2W	CHART
15	5310-08975-00	U1, U2, U3	4049	3
16	5310-09882-00	U6, U7, U10, U11	4001	4
17	5680-08969-00	U8, U9	UDM-7180	2
18	5680-08968-00	CHART	UDM-8118	CHART
19	5010-09534-00	CHART	RES. ZERO OHM	CHART
20	5788-12378-00	PCB	BALLY R-DISPLAY PCB	1
21	03-8088-1	(SUPPORT) S	SUPPORT DISPLAY	5
22	SEE CHART	LABEL	ASSEMBLY I.D. LABEL	CHART

OPTION	ITEM 9	ITEM 11	ITEM 12	ITEM 13	ITEM 14	ITEM 18	ITEM 19	ITEM 22
NOTE 6	DESIGNATION	QTY	DESIGNATION	QTY	DESIGNATION	QTY	DESIGNATION	QTY
-01	NOT USED	0	R42, R44, R46, R50, R52, R63	32	SEE NOTE 2	1	R45, R81	7
-02	J4	1	SEE NOTE 1	28	R9, R19	3	SEE NOTE 3	4
-03	J4, J6	2	SEE NOTE 1	28	R9, R18, R19, R20	5	SEE NOTE 3	4

- NOTES:**
- 100K ohm RESISTORS R38, R40, R48, R54-R61, R65, R67, R69, R71, R73, R75-R83, R85
SEE CHART ALSO
 - 1M ohm RESISTORS R88
SEE CHART ALSO
 - 8.2K ohm RESISTORS R49, R64, R68, R74
SEE CHART ALSO
 - 10K ohm RESISTOR R39, R43, R66, R70, R72, R84
SEE CHART ALSO
 - THE CHART SPECIFIES RESISTORS, I.C.s, AND CONNECTORS THAT ARE OPTION SPECIFIC
 - THE TWO LAST DIGITS OF THE PART NUMBER SPECIFIES THE SUB-ASSEMBLY OPTION.
-01 MAIN DISPLAY ONLY: ALPHA NUMERIC
-02 MAIN DISPLAY: NUMERIC, ONE EXTENDED 7-SEGMENT NUMERIC
-03 MAIN DISPLAY: NUMERIC, TWO EXTENDED 7-SEGMENT NUMERIC
 - CUT KEYING PINS AS INDICATED
 - ALIGN TOP EDGE OF GLASS DISPLAY WITH TOP EDGE OF DISPLAY SUPPORTS.
 - FOR SCHEMATIC SEE DRAWING 16-9068

ITEM	PART NUMBER	DESCRIPTION	QTY	ITEM	PART NUMBER	DESCRIPTION	QTY
THE INFO CONTAINED ON THIS DRAWING IS CONFIDENTIAL PROPERTY OF WILLIAMS ELECTRONICS GAMES, INC. IT MAY NOT BE USED OR DISCLOSED TO OTHERS WITHOUT WRITTEN PERMISSION.							
PROJ ENGR J BOYDSTON		DO NOT SCALE WORK TO DIMENSIONS SHOWN		REMOVE BURRS-BREAK SHARP CORNERS & EDGES TOLERANCES UNLESS OTHERWISE SPECIFIED DECIMAL .005 ANGULAR ±1/2°		WILLIAMS ELECTRONICS, INC. 3401 N CALIFORNIA AVE CHICAGO IL 60618	
DWN BY DATE J PARRISH		CHECKED BY DATE J Boydston 5-1-89		FIRST PROJECT NO 2008		NAME BALLY R-DISPLAY ASSY	
APPROVAL J Boydston 5/1/89		DATE 5/1/89		FIRST USAGE 2008-1N		MATERIAL SCALE 2/1 SHT 1 OF 1 PART NO D-12502- REV -	

REV	DESCRIPTION OF CHANGE	ECN NO	DATE
-	N. P. R.	5-1-89	2113 O

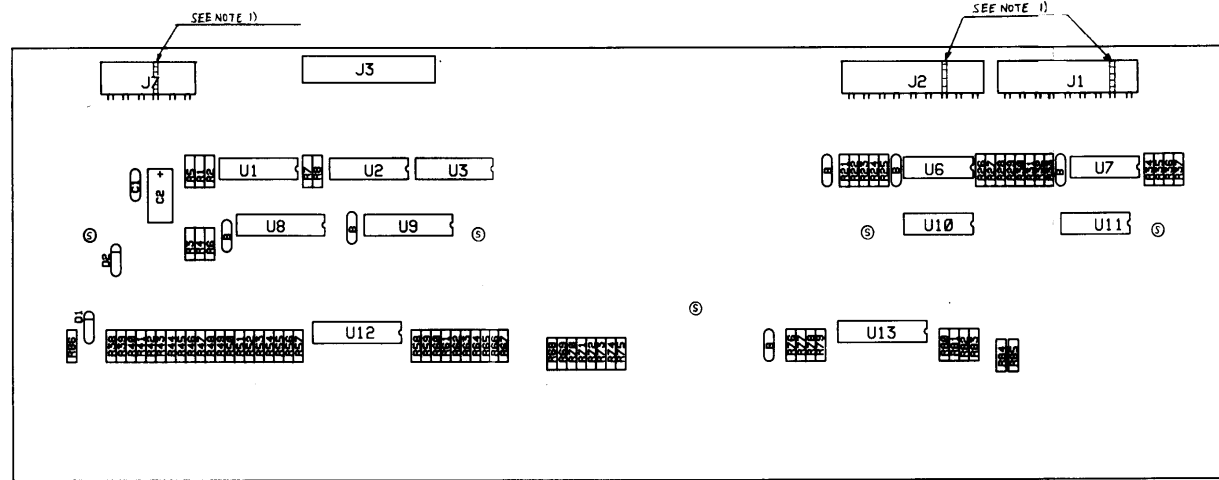

BALLY L-DISPLAY
BILL OF MATERIALS

ITEM	PART NUMBER	PART DESIGNATION	DESCRIPTION	QTY
1	5043-08980-00	C	BYPASS CAP	6
2	5043-08998-00	C1	CAP. 0.1MF 50V AX. CR.	1
3	5040-08343-00	C2	CAP. 10MF 25V AX. ELUCT.	1
4	5075-09135-00	D1, D2	ZENER 1M4740 10V	2
5	5670-12308-00	DSFY1	DISPLAY, 16-CHARACTER A/W	1
6	5791-10869-09	J1, J2	9 PIN HEADER, R/A	156
7	5791-10851-00	J3	28 PIN HEADER, R/A	100
8	5791-10869-06	J7	6 PIN HEADER, R/A	156
9	5010-08773-00	R1-R8, R21-R37	RES. 18K ohm 1/4W	25
10	5010-09182-00	R38, R40, R42, R44, R46, R48, R50, R52, R54, R55, R61, R63, R65, R67, R69, R71, R73, R75, R83, R85	RES. 100K ohm 1/4W	32
11	5010-08981-00	R39, R41, R43, R47, R53, R66, R70, R72, R84	RES. 10K ohm 1/2W	9
12	5010-10927-00	R45, R49, R51, R62, R64, R68, R74	RES. 8.2K ohm 1/2W	7
13	5010-10258-00	R86	RES. 1M ohm 1/4W	1
14	5310-08975-00	U1, U2, U3	4049	3
15	5310-08892-00	U6, U7, U10, U11	4001	4
16	5680-08969-00	U8, U9	UDM-7180	2
17	5680-08968-00	U12, U13	UDM-6118	2
18	5768-12408-00	PCB	BALLY-HI-DISPLAY PCB	1
19	03-8088-1	SUPPORT	SUPPORT DISPLAY	5

NOTES:

- 1) CUT KEYING PINS AS INDICATED.
- 2) ALIGN TOP EDGE OF GLASS DISPLAY WITH TOP EDGE OF DISPLAY SUPPORT.
- 3) FOR SCHEMATIC SEE DRAWING 16-9069

ITEM	PART NUMBER	DESCRIPTION	QTY	ITEM	PART NUMBER	DESCRIPTION	QTY
THE INFO CONTAINED ON THIS DRAWING IS CONFIDENTIAL PROPERTY OF WILLIAMS ELECTRONICS GAMES, INC. IT MAY NOT BE USED OR DISCLOSED TO OTHERS WITHOUT WRITTEN PERMISSION							
PROJ ENGR J. BOYASTON		DO NOT SCALE WORK TO DIMENSIONS SHOWN		REMOVE BURRS-BREAK SHARP CORNERS & EDGES		TOLERANCES UNLESS OTHERWISE SPECIFIED DECIMAL .005 ANGULAR .1/2° XXX .005 FRACTIONAL 2/64	
DWN BY DATE J. PARRICH		FIRST PROJECT NO 2008		MATERIAL		WILLIAMS ELECTRONICS, INC. 3401 N. CALIFORNIA AVE CHICAGO IL 60618	
CHECKED BY DATE J. PARRICH 5-1-89		FIRST USAGE 2008-1N		SCALE 2/1		NAME BALLY L-DISPLAY ASSY	
APPROVAL [Signature]		DATE 5/1/89		QTY 1		SHT. OF 1 PART NO D-12706	

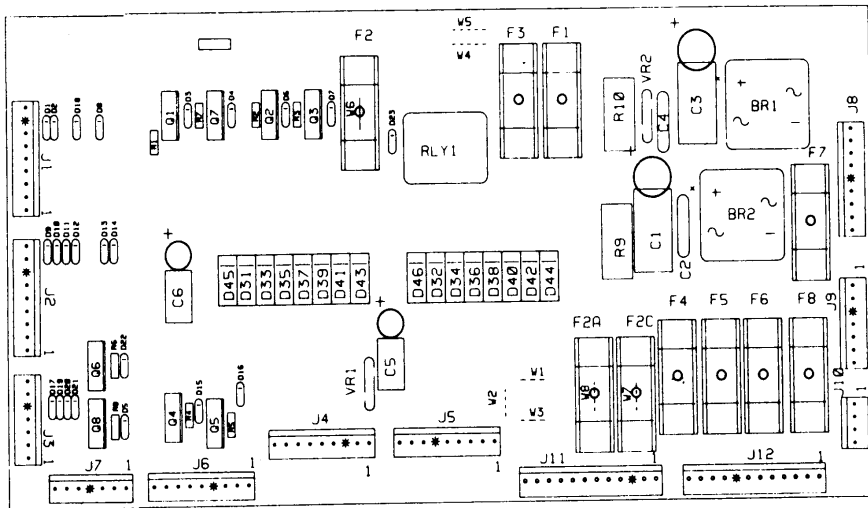

AUX POWER DRIVER UNIT BOARD
p/n D-12247

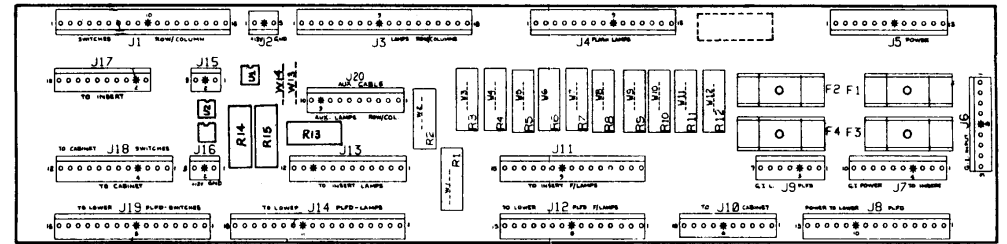

BACKBOX INTERCONNECT BOARD
p/n D-12313

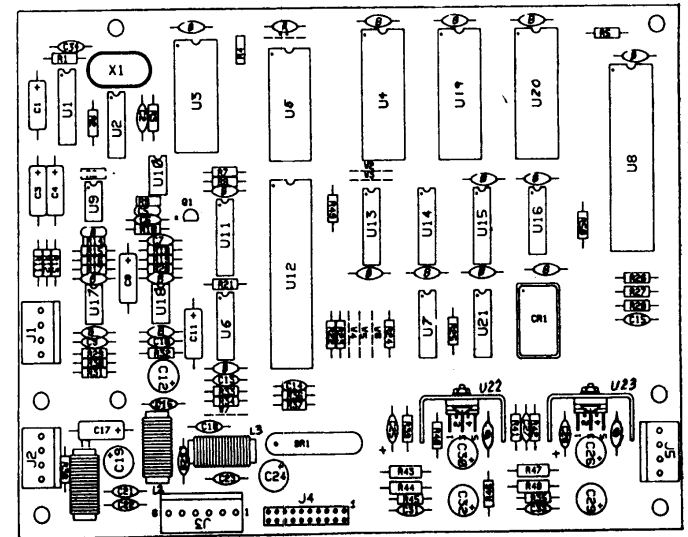

AUDIO BOARD ASSEMBLY
p/n D-11581

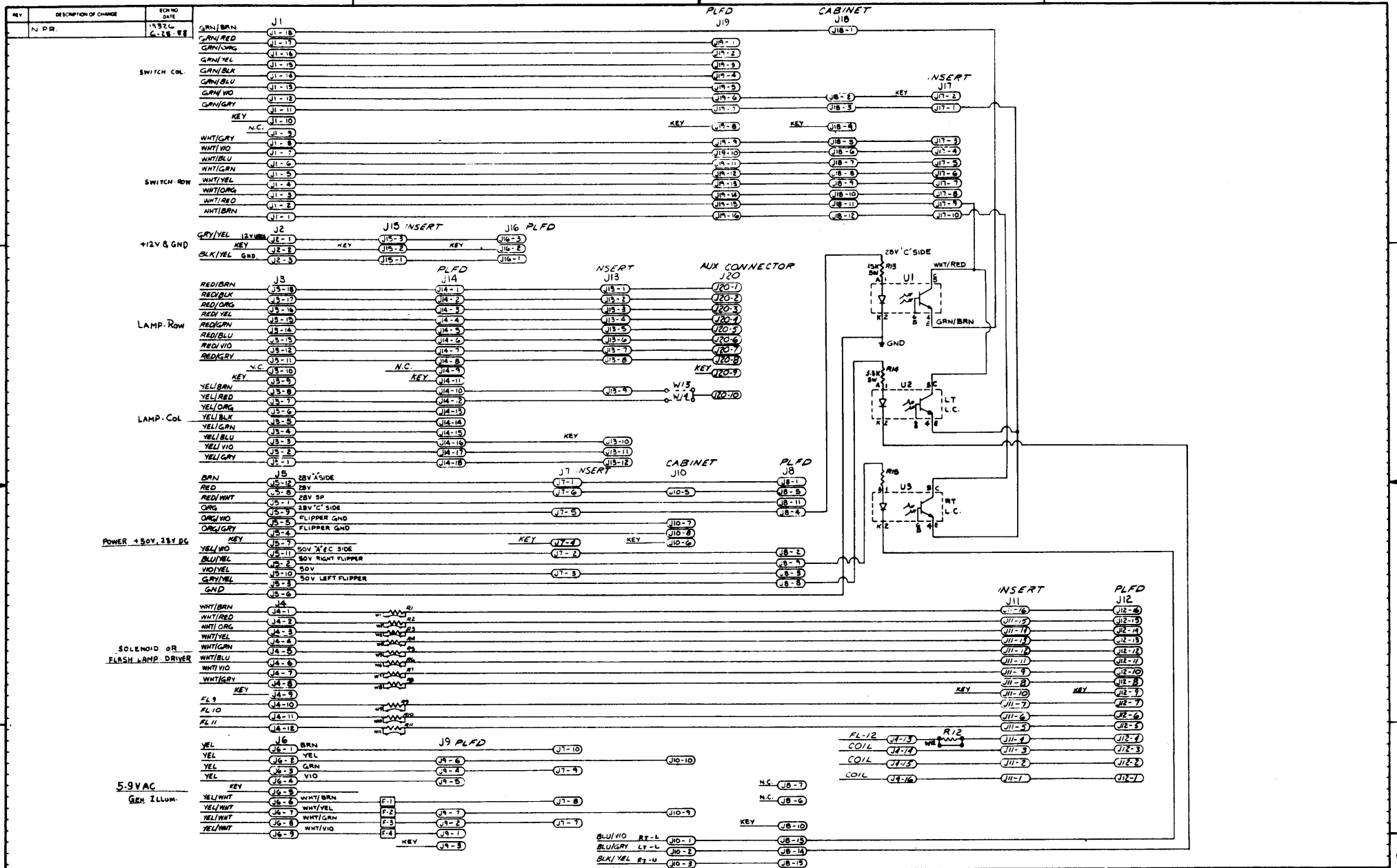

ITEM	PART NUMBER	DESCRIPTION	QTY	ITEM	PART NUMBER	DESCRIPTION	QTY
PROJ ENGR	M. JAYSHAL	DO NOT SCALE WORK TO DIMENSIONS SHOWN		WILLIAMS ELECTRONICS, INC. 3401 N CALIFORNIA AVE CHICAGO IL 60618 NAME SCHEMATIC - INTERCONNECT BOARD.			
DRN BY	DATE	REMOVE BURRS - BREAK SHARP CORNERS & EDGES					
CHECKED BY	DATE	TOLERANCES UNLESS OTHERWISE SPECIFIED		SCALE	SHT. OF	PART NO	REV
APPROVAL	DATE	DECIMAL .0005 ANGULAR 1/2°		1/5		16-9052-1	
		XXX .005 FRACTIONAL ±1/64					
		MATERIAL					
		FIRST PROJECT NO					
		FIRST USAGE					
		QTY					

Backbox Interconnect Brd. 3-16 Backbox Interconnect Board D-12313

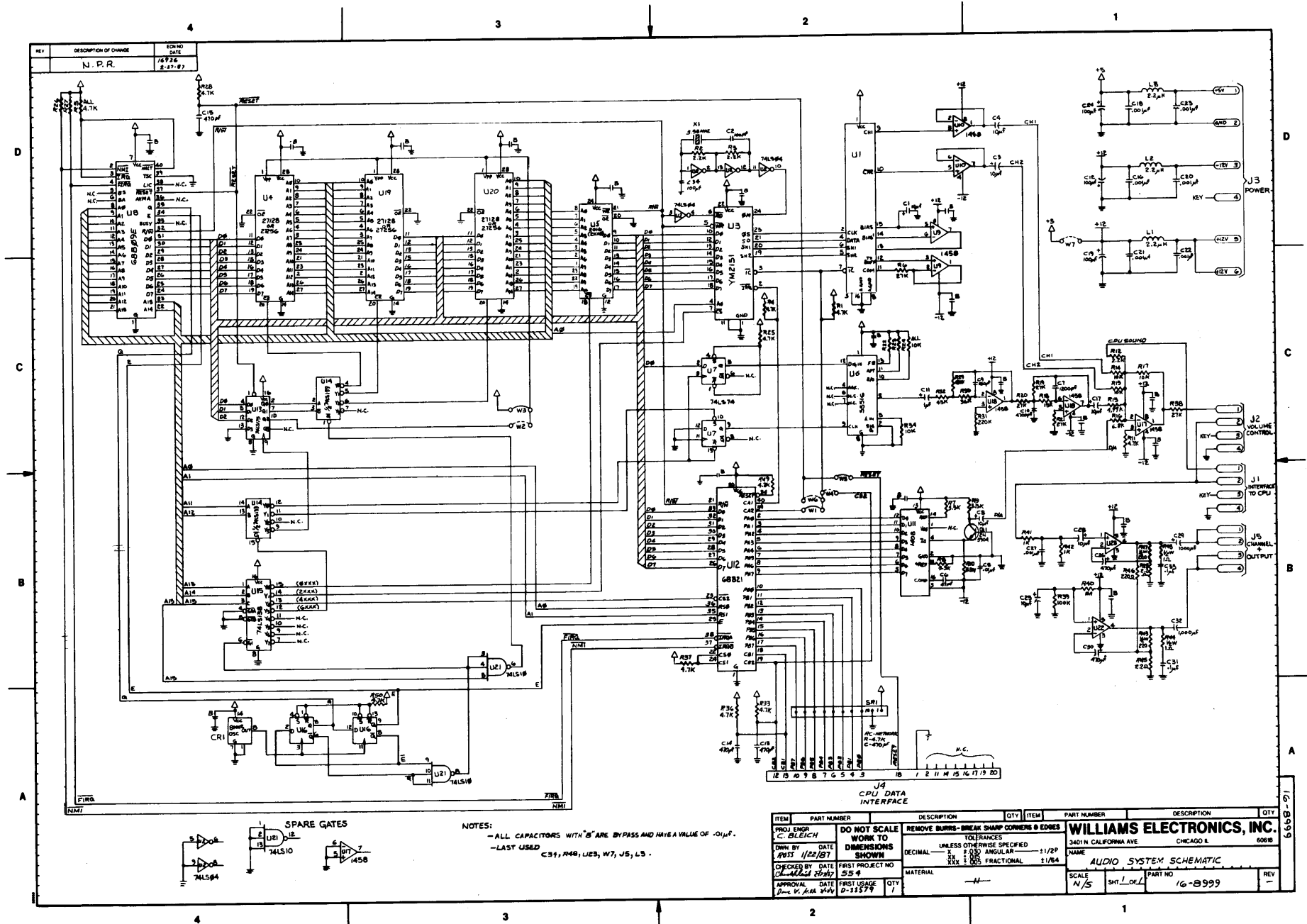

Audio Board (D-11581) Schematic

REV	DESCRIPTION OF CHANGE	ECN NO
	N.P.R.	17886
A	SEE COVER SHEET	181
B	ADDED W1, W2, FEA, AND F3C	182

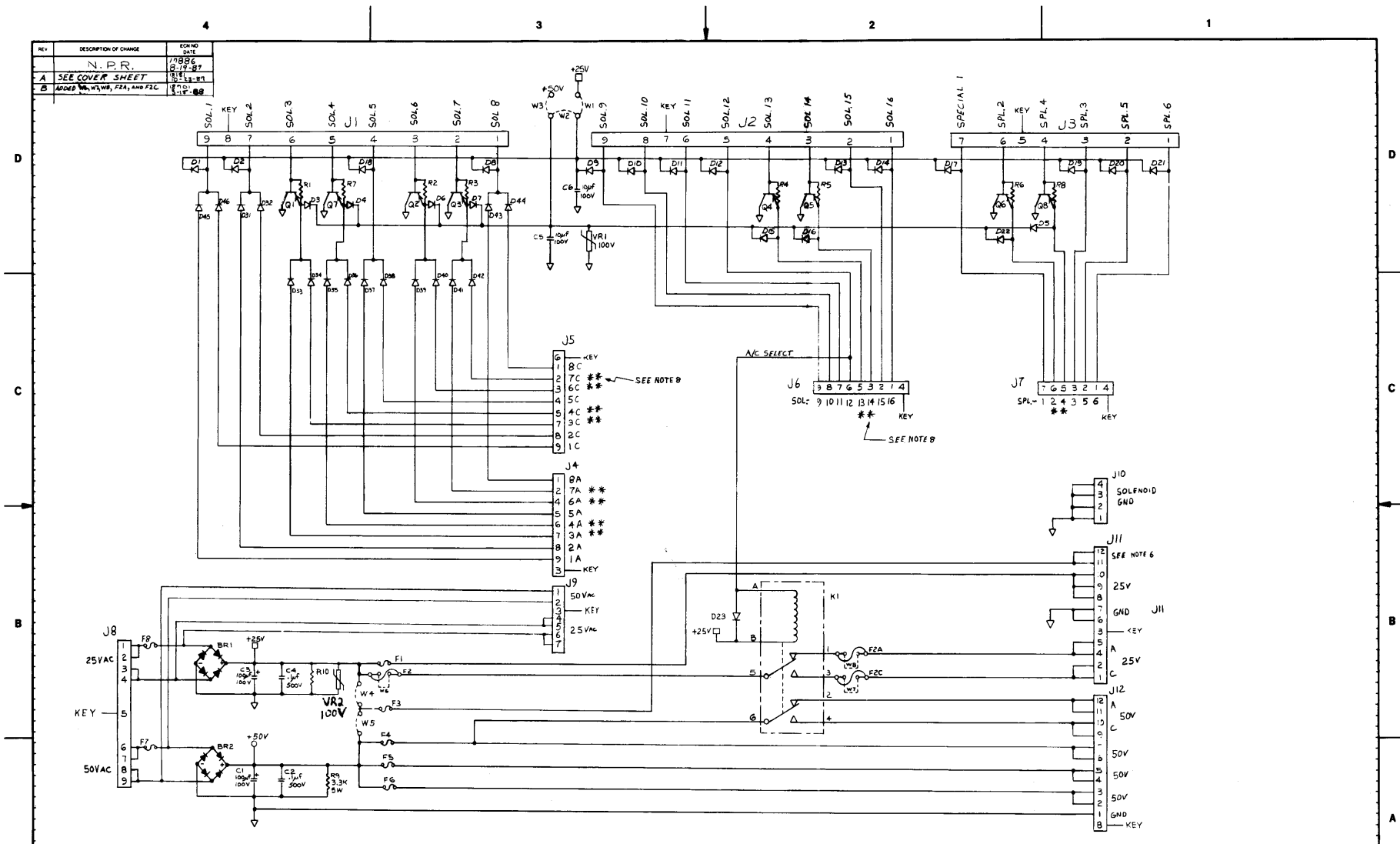

- NOTES:
- R1 - R5, 220Ω, 1/4 W
 - Q1 - Q8, TIP-36C
 - D1 - D23, 1N4003
 - D21 - D46, MR501
 - BR1, BR2, 35A 250V
 - W1, W2, W3, W4 JUMPERS SELECT COMBINATION OF 25V AND 50V COILS; W5, W6, W7 JUMPERS SELECT 50V COILS.
 - F1 - F6, SEE APPROPRIATE ASSEMBLY FOR FUSE VALUES (D-11813-).
 - * 50V COILS ONLY; ** 50V COIL OR FLASH LAMP ONLY.
 - VOLTAGES SPECIFIED UNDER FULL LOAD CONDITIONS.

ITEM	PART NUMBER	DESCRIPTION	QTY	ITEM	PART NUMBER	DESCRIPTION	QTY
PROJ ENGR	K. DEGER	DO NOT SCALE WORK TO DIMENSIONS SHOWN		REMOVE BURRS - BREAK SHARP CORNERS & EDGES		TOLERANCES UNLESS OTHERWISE SPECIFIED	
DWN BY	ROSS 7-7-87			DECIMAL	XX 1 00	ANGULAR	1/12°
CHECKED BY	DATE	FIRST PROJECT NO	557	MATERIAL	XXX 1 00	FRACTIONAL	1/16"
APPROVAL	DATE	FIRST USAGE	557-BB-1				

WILLIAMS ELECTRONICS, INC.	
3401 N. CALIFORNIA AVE CHICAGO IL 60648	
NAME: SCHEMATIC - AUX. PWR DR. R.	
SCALE: N/S	SHT. LOR. PART NO. 16-9015
	REV B

Aux Power Driver Board Schematic

SWITCHED SOLENOIDS

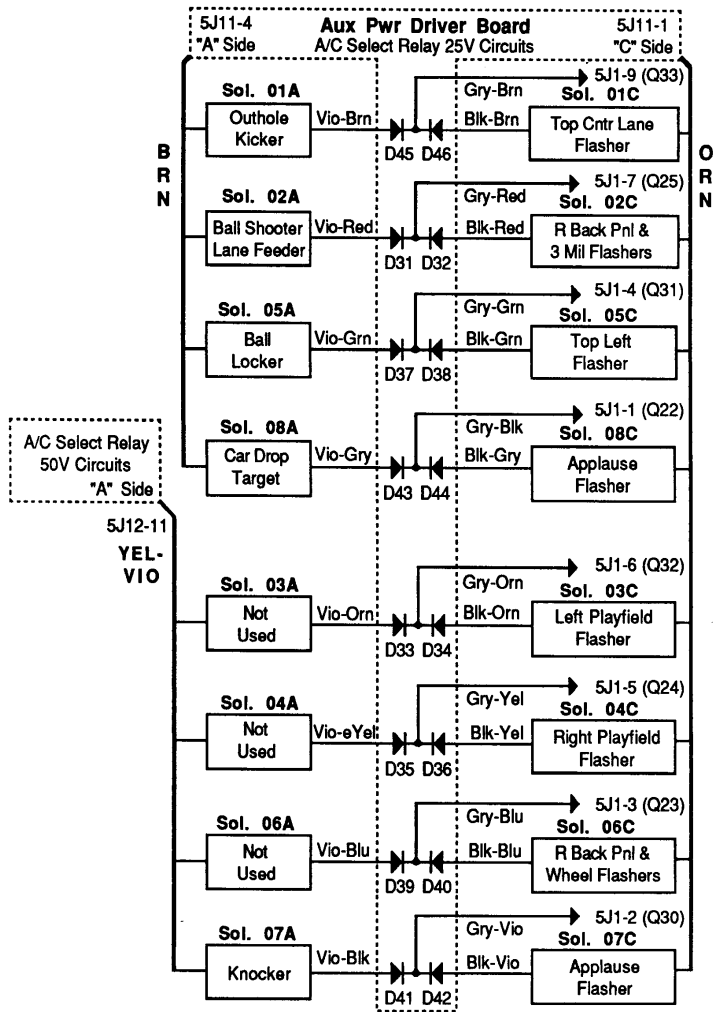

CONTROLLED SOLENOIDS (25V)

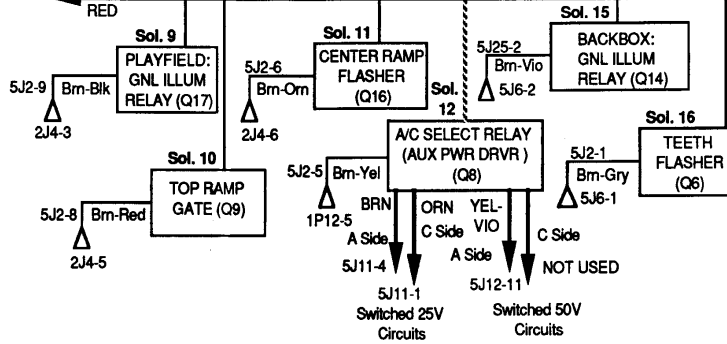

SPECIAL SOLENOIDS (25V)

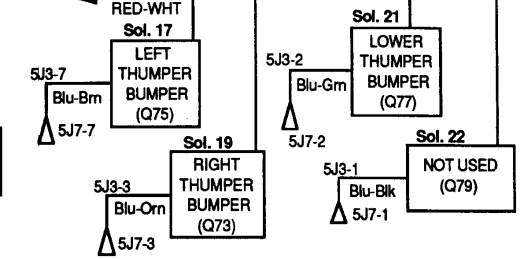

SPECIAL SOLENOIDS (50V)

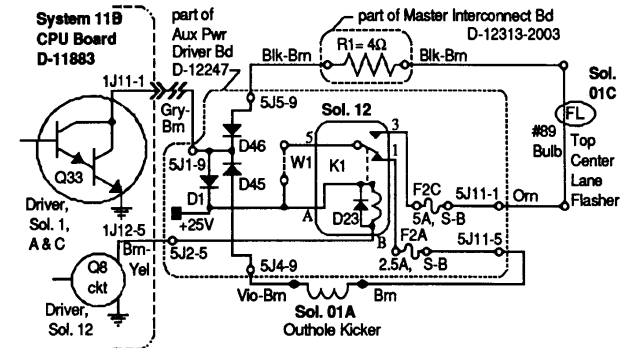
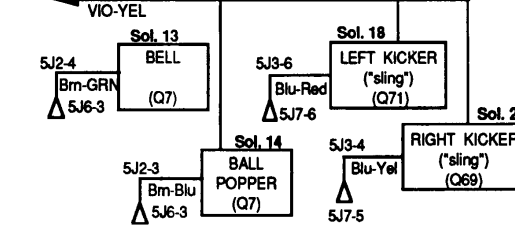

Controlled, Special & , Switched Solenoids

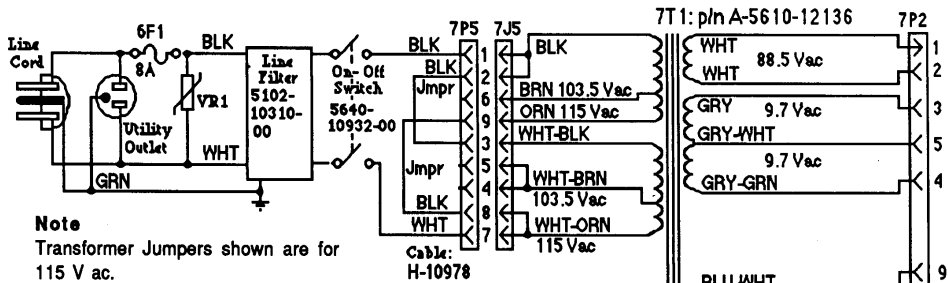

Note
Transformer Jumpers shown are for 115 V ac.
See Transformer Jumper Chart for

Transformer Jumper Chart

206/218 VAC	230 VAC	103.5 VAC
<p>7P5</p> <p>BLK 1</p> <p>206Y 2</p> <p>218Y 6</p> <p>WHT 3</p> <p>WHT 4</p> <p>WHT 5</p> <p>WHT 8</p> <p>WHT 7</p>	<p>7P5</p> <p>BLK 1</p> <p>2 2</p> <p>6 6</p> <p>9 9</p> <p>WHT 3</p> <p>WHT 4</p> <p>WHT 5</p> <p>WHT 8</p> <p>WHT 7</p>	<p>7P5</p> <p>BLK 1</p> <p>2 2</p> <p>6 6</p> <p>9 9</p> <p>WHT 3</p> <p>WHT 4</p> <p>WHT 5</p> <p>WHT 8</p> <p>WHT 7</p>
FUSE (6F1): 4A, S-B	4A, S-B	8A, N-B
VARISTOR: 275V	275V	130V
275V Varistor: 5017-09063-00 130V Varistor: 5017-09044-00 4A, S-B Fuse: 5731-06314-00 (for 220V) 8A, N-B Fuse: 5730-09252-00 (for 115V)		

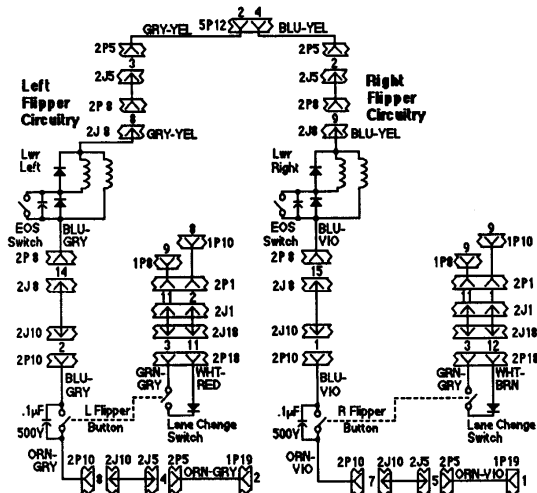

7T1: p/n A-5610-12136

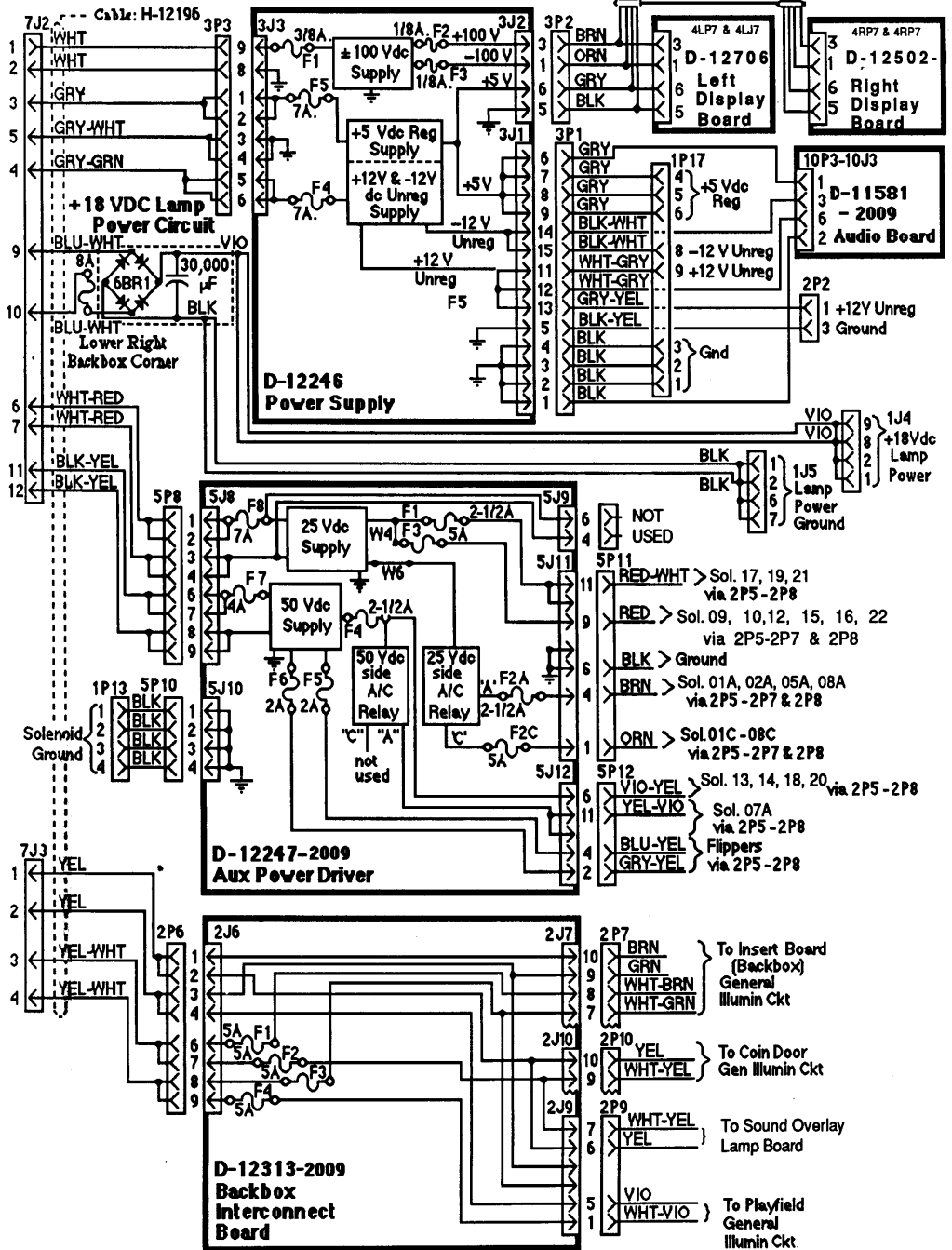

Power Wiring

BACKBOX INTERCONNECT BOARD INTERBOARD SIGNALS

BACKBOX INTERCONNECT BOARD INTERBOARD SIGNALS

AUX POWER DRIVER INTERBOARD SIGNALS

Connector	Wire Color	Signal Designation/Description	Connector	Wire Color	Signal Designation/Description
5J1-1	GRY-BLK	CPU: Solenoid 8 (Q22) / 1J11-9	5J2-1	BRN-GRY	CPU: Solenoid 16 (Q6) / 1J12-9
5J1-2	GRY-VIO	CPU: Solenoid 7 (Q30) / 1J11-8	5J2-2	BRN-VIO	CPU: Solenoid 15 (Q14) / 1J12-8
5J1-3	GRY-BLU	CPU: Solenoid 6 (Q23) / 1J11-7	5J2-3	BRN-BLU	CPU: Solenoid 14 (Q7) / 1J12-7
5J1-4	GRY-GRN	CPU: Solenoid 5 (Q31) / 1J11-6	5J2-4	---	No Connection
5J1-5	GRY-YEL	CPU: Solenoid 4 (Q24) / 1J11-5	5J2-5	BRN-YEL	CPU: Solenoid 12 (Q6) / 1J12-5
5J1-6	GRY-ORG	CPU: Solenoid 3 (Q32) / 1J11-4	5J2-6	BRN-ORG	CPU: Solenoid 11 (Q16) / 1J12-4
5J1-7	GRY-RED	CPU: Solenoid 2 (Q25) / 1J11-3	5J2-7	Key Pin	No Connection
5J1-8	Key Pin	No Connection	5J2-8	BRN-RED	CPU: Solenoid 10 (Q9) / 1J12-3
5J1-9	GRY-BRN	CPU: Solenoid 1 (Q33) / 1J11-1	5J2-9	BRN-BLK	CPU: Solenoid 9 (Q11) / 1J12-1
5J3-1	BLU-BLK	CPU: Solenoid 22 (Q79) / 1J19-9	5J4-1	VIO-GRY	Solenoid 08A
5J3-2	BLU-GRN	CPU: Solenoid 21 (Q77) / 1J19-8	5J4-2	VIO-BLK	Solenoid 07A
5J3-3	BLU-ORG	CPU: Solenoid 19 (Q73) / 1J19-3	5J4-3	Key Pin	No Connection
5J3-4	BLU-YEL	CPU: Solenoid 20 (Q69) / 1J19-6	5J4-4	---	No Connection
5J3-5	Key Pin	No Connection	5J4-5	VIO-GRN	Solenoid 05A
5J3-6	BLU-RED	CPU: Solenoid 18 (Q71) / 1J19-4	5J4-6	---	No Connection
5J3-7	BLU-BRN	CPU: Solenoid 17 (Q75) / 1J19-7	5J4-7	---	No Connection
5J4-1	---	No Connection	5J4-8	VIO-RED	Solenoid 02A
5J4-2	---	No Connection	5J4-9	VIO-BRN	Solenoid 01A
5J5-1	WHT-GRY	Solenoid 08C / 2J4-8	5J6-1	BRN-GRY	Solenoid 16 / 2J4-15
5J5-2	WHT-VIO	Solenoid 07C / 2J4-7	5J6-2	BRN-VIO	Solenoid 15 / 2J4-10
5J5-3	WHT-BLU	Solenoid 06C / 2J4-6	5J6-3	BRN-BLU	Solenoid 14 / 2J4-14
5J5-4	WHT-GRN	Solenoid 05C / 2J4-5	5J6-4	Key Pin	No Connection
5J5-5	WHT-YEL	Solenoid 04C / 2J4-4	5J6-5	---	No Connection
5J5-6	Key Pin	No Connection	5J6-6	---	No Connection
5J5-7	WHT-ORG	Solenoid 03C / 2J4-3	5J6-7	BRN-ORG	Solenoid 11 / 2J4-12
5J5-8	WHT-RED	Solenoid 02C / 2J4-2	5J6-8	BRN-FED	Solenoid 10 / 2J4-11
5J5-9	WHT-BRN	Solenoid 01C / 2J4-1	5J6-9	BRN-BLK	Solenoid 09 / 2J4-16
5J7-1	---	No Connection	5J8-1	WHT-RED	Transformer: 26V ac / 7J2-6
5J7-2	BLU-GRN	Solenoid 21	5J8-2	WHT-RED	Transformer: 26V ac / 7J2-6
5J7-3	BLU-ORG	Solenoid 19	5J8-3	WHT-RED	Transformer: 26V ac / 7J2-7
5J7-4	Key Pin	No Connection	5J8-4	WHT-RED	Transformer: 26V ac / 7J2-7
5J7-5	BLU-YEL	Solenoid 20	5J8-5	Key Pin	No Connection
5J7-6	BLU-RED	Solenoid 18	5J8-6	BLK-YEL	Transformer: 48V ac / 7J2-11
5J7-7	BLU-BRN	Solenoid 17	5J8-7	BLK-YEL	Transformer: 48V ac / 7J2-11
5J9-1	---	No Connection	5J8-8	BLK-YEL	Transformer: 48V ac / 7J2-12
5J9-2	---	No Connection	5J8-9	BLK-YEL	Transformer: 48V ac / 7J2-12
5J9-3	---	No Connection	5J10-1	BLK	Sold Gnd / 1J13-1
5J9-4	---	No Connection	5J10-2	BLK	Sold Gnd / 1J13-2
5J9-5	---	No Connection	5J10-3	BLK	Sold Gnd / 1J13-3
5J9-6	---	No Connection	5J10-4	BLK	Sold Gnd / 1J13-4
5J9-7	---	No Connection	5J11-1	ORG	+25 Vdc "C" Solenoid Pwr/2J5-9
5J12-1	---	No Connection	5J11-2	---	No Connection
5J12-2	GRY-YEL	+50 Vdc Flipper Pwr/2J5-3	5J11-3	Key Pin	No Connection
5J12-3	---	No Connection	5J11-4	BRN	+25 Vdc "A" Solenoid Pwr/2J5-11
5J12-4	BLU-YEL	+50 Vdc Flipper Pwr/2J5-2	5J11-5	---	No Connection
5J12-5	---	No Connection	5J11-6	BLK	Ground/2J5-6
5J12-6	VIO-YEL	+50 Vdc Solenoid Pwr/2J5-10	5J11-7	---	No Connection
5J12-7	---	No Connection	5J11-8	---	No Connection
5J12-8	Key Pin	No Connection	5J11-9	RED	+25 Vdc Solenoid Pwr/2J5-8
5J12-9	---	No Connection	5J11-10	---	No Connection
5J12-10	---	No Connection	5J11-11	RED-WHT	+25 Vdc Solenoid Pwr/2J5-1
5J12-11	YEL-VIO	+50 Vdc Solenoid Pwr/2J5-11	5J11-12	---	No Connection
5J12-12	---	No Connection			

Connector	Wire Color	Signal Designation/Description	Connector	Wire Color	Signal Designation/Description
2J1-1	WHT-BRN	Switch Row 1 / 1J11-9	2J2-1	GRY-YEL	+12Vdc Unreg/3J1-13
2J1-1	WHT-FED	Switch Row 2 / 1J11-8	2J2-2	---	No Connection
2J1-3	WHT-ORG	Switch Row 3 / 1J11-7	2J2-3	BLK-YEL	Ground/3J1-5
2J1-4	WHT-YEL	Switch Row 4 / 1J11-6	2J3-1	YEL-GRY	Lamp Col 8 (O51/52)/1J7-9
2J1-5	WHT-GRN	Switch Row 5 / 1J11-5	2J3-2	YEL-VIO	Lamp Col 7 (O53/54)/1J7-8
2J1-6	WHT-BLU	Switch Row 6 / 1J11-3	2J3-3	YEL-BLU	Lamp Col 6 (O55/56)/1J7-7
2J1-7	WHT-VIO	Switch Row 7 / 1J11-2	2J3-4	YEL-GRN	Lamp Col 5 (O57/58)/1J7-6
2J1-8	WHT-GRY	Switch Row 8 / 1J11-1	2J3-5	YEL-BLK	Lamp Col 4 (O58/60)/1J7-4
2J1-9	Key Pin	No Connection	2J3-6	YEL-ORG	Lamp Col 3 (O61/62)/1J7-3
2J1-10	---	No Connection	2J3-7	YEL-FED	Lamp Col 2 (O63/64)/1J7-2
2J1-11	GRN-GRY	Switch Col 8 (Q46) / 1J8-9	2J3-8	YEL-BRN	Lamp Col 1 (O65/66)/1J7-1
2J1-12	GRN-VIO	Switch Col 7 (Q42) / 1J8-8	2J3-9	Key Pin	No Connection
2J1-13	GRN-BLU	Switch Col 6 (Q47) / 1J8-7	2J3-10	---	No Connection
2J1-14	GRN-BLK	Switch Col 5 (Q43) / 1J8-5	2J3-11	RED-GRY	Lamp Row 8 (O87) / 1J6-9
2J1-15	GRN-YEL	Switch Col 4 (Q48) / 1J8-4	2J3-12	RED-VIO	Lamp Row 7 (O86) / 1J6-8
2J1-16	GRN-ORG	Switch Col 3 (Q44) / 1J8-3	2J3-13	RED-BLU	Lamp Row 6 (O85) / 1J6-7
2J1-17	GRN-FED	Switch Col 2 (Q49) / 1J8-2	2J3-14	RED-GRN	Lamp Row 5 (O84) / 1J6-6
2J1-18	GRN-BRN	Switch Col 1 (Q45) / 1J8-1	2J3-15	RED-YEL	Lamp Row 4 (O83) / 1J6-5
2J4-1	WHT-BRN	Solenoid 01C in / 5J5-9	2J3-16	RED-ORG	Lamp Row 3 (O82) / 1J6-3
2J4-2	WHT-FED	Solenoid 02C in / 5J5-8	2J3-17	RED-BLK	Lamp Row 2 (O81) / 1J6-2
2J4-3	WHT-ORG	Solenoid 03C in / 5J5-7	2J3-18	RED-BRN	Lamp Row 1 (O80) / 1J6-1
2J4-4	WHT-YEL	Solenoid 04C in / 5J5-5	2J5-1	RED-WHT	+25Vdc (Solenoid)/5J11-12
2J4-5	WHT-GRN	Solenoid 05C in / 5J5-4	2J5-2	BLU-YEL	Flipper Power/5J12-2
2J4-6	WHT-BLU	Solenoid 06C in / 5J5-3	2J5-3	GRY-YEL	Flipper Power/5J12-2
2J4-7	WHT-VIO	Solenoid 07C in / 5J5-2	2J5-4	ORG-GRY	Flipper Ground Ckt/1J19-2
2J4-8	WHT-GRY	Solenoid 08C in / 5J5-1	2J5-5	ORG-VIO	Flipper Ground Ckt/1J19-1
2J4-9	Key Pin	No Connection	2J5-6	BLK	Ground/5J11-6
2J4-10	BRN-ORG	Solenoid 11 / 5J6-7	2J5-7	Key Pin	No Connection
2J4-11	BRN-GRY	Solenoid 16 / 5J6-1	2J5-8	RED	+25 Vdc (Solenoid)/ 5J11-9
2J4-12	BRN-BLK	Solenoid 09 / 5J6-9	2J5-9	ORG	+25 Vdc ("C" Solenoids)/ 5J11-1
2J4-13	BRN-FED	Solenoid 10 / 5J6-8	2J5-10	VIO-YEL	+50 Vdc (Solenoid)/ 5J12-2
2J4-14	---	No Connection	2J5-11	YEL-VIO	+50 Vdc (Solenoid)/ 5J12-11
2J4-15	BRN-BLU	Solenoid 14 / 5J6-3	2J5-12	BRN	+25 Vdc ("A" Solenoids)/5J11-5
2J4-16	BRN-VIO	Solenoid 15 / 5J6-2	2J7-1	---	No Connection
2J6-1	YEL	Gen Illum Pwr: 6V ac	2J7-2	---	No Connection
2J6-2	YEL	Gen Illum Pwr: 6V ac	2J7-3	---	No Connection
2J6-3	YEL	Gen Illum Pwr: 6V ac	2J7-4	---	No Connection
2J6-4	YEL	Gen Illum Pwr: 6V ac	2J7-5	ORG	+25 Vdc ("C" Solenoids)
2J6-5	Key Pin	No Connection	2J7-6	RED	+25 Vdc (Solenoid)
2J6-6	YEL-WHT	Gen Illum Pwr: 6V ac	2J7-7	WHT-GRN	Backbox Gen Illum Pwr/2J6-8
2J6-7	YEL-WHT	Gen Illum Pwr: 6V ac	2J7-8	WHT-BRN	Backbox Gen Illum Pwr/2J6-6
2J6-8	YEL-WHT	Gen Illum Pwr: 6V ac	2J7-9	GRN	Backbox Gen Illum Pwr/2J6-3
2J6-9	YEL-WHT	Gen Illum Pwr: 6V ac	2J7-10	BRN	Backbox Gen Illum Pwr/2J6-1
2J8-1	BRN	+25 Vdc ("A" Solenoids)	2J9-1	WHT-VIO	Playfield Gen Illum Pwr/2J6-9
2J8-2	YEL-VIO	+50 Vdc Solenoid 03A, 04A, 06A	2J9-2	---	No Connection
2J8-3	VIO-YEL	+50 Vdc Solenoid 14, 18, 20	2J9-3	---	No Connection
2J8-4	ORG	+25 Vdc ("C" Solenoids)	2J9-4	---	No Connection
2J8-5	FED	+25 Vdc Solenoid 9-11, 15, 16	2J9-5	VIO	Playfield Gen Illum Pwr/2J6-4
2J8-6-7	---	No Connection	2J9-6	YEL	Snd Overlay Lamp Brd J5 / 4
2J8-8	GRY-YEL	Flipper Power	2J9-7	WHT-YEL	Snd Overlay Lamp Brd J5 / 2
2J8-9	BLU-YEL	Flipper Power			
2J8-10	Key Pin	No Connection			
2J8-11	RED-WHT	+25Vdc Solenoid 17, 18, 21	2J11-1	BRN-BLK	Solenoid 9
2J8-12	---	No Connection	2J11-2	BLK-FED	Solenoid 02C
2J8-13	---	No Connection	2J11-3	BLK-ORG	Solenoid 03C
2J8-14	BLU-GRY	Lower L Flipper	2J11-4	BLK-YEL	Solenoid 04C
2J8-15	BLU-VIO	Lwr R Flipper	2J11-5	---	No Connection
2J10-1	BLU-VIO	Lwr R Flipper Switch	2J11-6	BLK-BLU	Solenoid 06C
2J10-2	BLU-GRY	Lwr L Flipper Switch	2J11-7	---	No Connection
2J10-3	---	No Connection	2J11-8	BLK-VIO	Solenoid 07C
2J10-4	---	No Connection	2J11-9	BLK-GRY	Solenoid 08C
2J10-5	FED	+25 Vdc (Solenoid)	2J11-10	---	No Connection
2J10-6	---	No Connection	2J11-11	BRN-GRY	Solenoid 16
2J10-7	ORG-VIO	R Flipper Ground Ckt	2J11-12	---	No Connection
2J10-8	ORG-GRY	L Flipper Ground Ckt	2J11-13	---	No Connection
2J10-9	WHT-YEL	Gen Illum Pwr: 6V ac	2J11-14	---	No Connection
2J10-10	YEL	Gen Illum Pwr: 6V ac	2J11-15	---	No Connection
2J11-1	---	No Connection	2J11-16	BRN-VIO	Solenoid 15
2J12-1	---	No Connection			
2J12-2	---	No Connection	2J12-1	---	No Connection
2J12-3	---	No Connection	2J12-2	BRN-BLU	Solenoid 14
2J12-4	---	No Connection	2J12-3	---	No Connection
2J12-5	---	No Connection	2J12-4	BRN-FED	Solenoid 10
2J12-6	---	No Connection	2J12-5	BRN-BLK	Solenoid 9
2J12-7	---	No Connection	2J12-6	---	No Connection
2J12-8	---	No Connection	2J12-7	BRN-ORG	Solenoid 11
2J12-9	---	No Connection	2J12-8	---	No Connection
2J12-10	---	No Connection	2J12-9	---	No Connection
2J12-11	---	No Connection	2J12-10	---	No Connection
2J12-12	---	No Connection	2J12-11	BLK-BLU	Solenoid 06C
			2J12-12	BLK-GRN	Solenoid 05C

Connector	Wire Color	Signal Designation/Description	Connector	Wire Color	Signal Designation/Description
2J14-1	RED-BRN	Lamp Row 1	2J18-13	BLK-YEL	Solenoid 04C
2J14-2	RED-BLK	Lamp Row 2	2J18-14	BLK-ORG	Solenoid 03C
2J14-3	RED-ORG	Lamp Row 3	2J18-15	BLK-FED	Solenoid 02C
2J14-4	RED-YEL	Lamp Row 4	2J18-16	BLK-BRN	Solenoid 01C
2J14-5	RED-GRN	Lamp Row 5	2J18-1	GRN-BRN	Switch Col 1
2J14-6	RED-BLU	Lamp Row 6	2J18-2-4	---	No Connection
2J14-7	RED-VIO	Lamp Row 7	2J18-5	WHT-GRY	Switch Flow 8
2J14-8	RED-GRY	Lamp Row 8	2J18-6	WHT-VIO	Switch Flow 7
2J14-9	---	No Connection	2J18-7	WHT-BLU	Switch Flow 6
2J14-10	YEL-BRN	Lamp Col 1	2J18-8	WHT-GRN	Switch Flow 5
2J14-11	---	No Connection	2J18-9	WHT-YEL	Switch Flow 4
2J14-12	YEL-FED	Lamp Col 2	2J18-10	WHT-ORG	Switch Flow 3
2J14-13	YEL-ORG	Lamp Col 3	2J18-11	---	No Connection
2J14-14	YEL-BLK	Lamp Col 4	2J18-12	WHT-BRN	Switch Flow 1
2J14-15	YEL-GRN	Lamp Col 5	2J19-9	WHT-GRY	Switch Flow 8
2J14-16	YEL-BLU	Lamp Col 6	2J19-10	WHT-VIO	Switch Flow 7
2J14-17	YEL-VIO	Lamp Col 7	2J19-11	WHT-BLU	Switch Flow 6
2J14-18	YEL-BLK	Lamp Col 8	2J19-12	WHT-GRN	Switch Flow 5
2J19-1	GRN-FED	Switch Col 2	2J19-13	WHT-YEL	Switch Flow 4
2J19-2	GRN-ORG	Switch Col 3	2J19-14	WHT-ORG	Switch Flow 3
2J19-3	GRN-YEL	Switch Col 4	2J19-15	WHT-FED	Switch Flow 2
2J19-4	GRN-BLK	Switch Col 5	2J19-16	WHT-BRN	Switch Flow 1
2J19-5	GRN-BLU	Switch Col 6			
2J19-6	GRN-VIO	Switch Col 7	2J16-1	BLK-YEL	No Connection
2J19-7	GRN-GRY	Switch Col 8	2J16-2		

POWER SUPPLY INTERBOARD SIGNALS

Connector	Wire Color	Signal Designation/Description	Connector	Wire Color	Signal Designation/Description
3J1-1	BLK	Ground / 11J3-2	3J2-1	ORG	Display Power: -100V dc / 4J7-1
3J1-2	BLK	Ground / 1J17-1	3J2-2	---	No Connection
3J1-3	BLK	Ground / 1J17-2	3J2-3	BRN	Display Power: +100V dc / 4J7-3
3J1-4	BLK	Ground / 1J17-3	3J2-4	---	No Connection
3J1-5	BLK-YEL	Logic Ground / 2J2-3	3J2-5	BLK	Ground (Display ckt) / 4J7-5
3J1-6	GRY	CPU Pwr: +5V dc Reg / 1J17-5	3J2-6	GRY	Display Power: +5V dc / 4J7-6
3J1-7	GRY	"/ 11J3-1			
3J1-8	GRY	"/ 1J17-4	3J3-1	GRY	Transformer: 19.4V ac, 1Ø, C. T.
3J1-9	GRY	"/ 1J17-6	3J3-2	GRY	Transformer: 19.4V ac, 1Ø, C. T.
3J1-10	Key Pin	No Connection	3J3-3	GRY-WHT	Transformer: 19.4V ac, C.T. com
3J1-11	WHT-GRY	CPU Pwr: +12V dc Unreg / 11J3-6	3J3-4	GRY-WHT	Transformer: 19.4V ac, C.T. com
3J1-12	WHT-GRY	CPU Power: +12V dc Unreg / 1J17-9	3J3-5	GRY-GRN	Transformer: 19.4V ac, 1Ø, C. T.
3J1-13	GRY-YEL	CPU Power: +12V dc Unreg / 2J2-1	3J3-6	GRY-GRN	Transformer: 19.4V ac, 1Ø, C. T.
3J1-14	BLK-WHT	CPU Pwr: -12V dc Unreg / 1J17-8	3J3-7	Key Pin	No Connection
3J1-15	BLK-WHT	CPU Pwr: -12V dc Unreg / 11J3-3	3J3-8	WHT	Transformer: 88.5V ac
			3J3-9	WHT	Transformer: 88.5V ac

AUDIO BOARD INTERBOARD SIGNALS

Connector	Wire Color	Signal Designation/Description	Connector	Wire Color	Signal Designation/Description
11J1-1	RED	Sound Input (from CPU) / 1J16-1	11J2-1	RED	Signal Level (to Vol Cntrl)
11J1-2	BLK	Sound Input (from CPU) / 1J16-2	11J2-2	BLK	Signal Level (from Vol Cntrl)
11J1-3	---	No Connection	11J2-3	---	No Connection
11J1-4	WHT	Ground / 1J16-4	11J2-4	shield	Ground
11J3-1	GRY	Power: +5 Vdc / 3J1-7	11J4	Ribbon Cable from Snd Only	Lamp Brd J1
11J3-2	BLK	Ground / 3J1-1			
11J3-3	BLK-WHT	Power: -12 Vdc Unreg / 3J1-15	11J5-1	BLK-YEL / Speaker	
11J3-4	---	No Connection	11J5-2	BLK-YEL / Speaker	
11J3-5	---	No Connection	11J5-3	BLK / Speaker	
11J3-6	WHT-GRY	Power: +12 Vdc Unreg / 3J1-11	11J5-4	BLK / Speaker	

LEFT DISPLAY INTERBOARD SIGNALS

Connector	Wire Color	Signal Designation/Description	Connector	Wire Color	Signal Designation/Description
4J1-1	BRN-GRY	ST-8: Digit Display Strobe / 1J1-1	4J2-1	VIO-GRY	ST-16: Digit Display Strobe / 1J2-1
4J1-2	BRN-VIO	ST-7: Display Digit Strobe / 1J1-2	4J2-2	VIO-BLK	ST-15: Display Digit Strobe / 1J2-2
4J1-3	BRN-BLU	ST-6: Display Digit Strobe / 1J1-3	4J2-3	VIO-BLU	ST-14: Display Digit Strobe / 1J2-3
4J1-4	BRN-GRN	ST-5: Display Digit Strobe / 1J1-4	4J2-4	VIO-GRN	ST-13: Display Digit Strobe / 1J2-4
4J1-5	BRN-YEL	ST-4: Display Digit Strobe / 1J1-5	4J2-5	VIO-YEL	ST-12: Display Digit Strobe / 1J2-5
4J1-6	BRN-ORG	ST-3: Display Digit Strobe / 1J1-6	4J2-6	VIO-ORG	ST-11: Display Digit Strobe / 1J2-6
4J1-7	BRN-FED	ST-2: Display Digit Strobe / 1J1-7	4J2-7	Key Pin	No Connection
4J1-8	Key Pin	No Connection	4J2-8	VIO-RED	ST-8: Display Digit Strobe / 1J2-8
4J1-9	BRN-BLK	ST-1: Display Digit Strobe / 1J1-9	4J2-9	VIO-BRN	ST-9: Display Digit Strobe / 1J2-9
4J3	Ribbon Cable	from CPU 1J22			
4J7-1	ORG	Display Power: -100V dc / 3J5-3	4J7-4	Key Pin	No Connection
4J7-2	---	No Connection	4J7-5	BLK	Ground / 3J5-1
4J7-3	BRN	Display Power: +100V dc / 3J5-4	4J7-6	GRY	Power: +5V dc / 3J5-6

RIGHT DISPLAY INTERBOARD SIGNALS

Connector	Wire Color	Signal Designation/Description	Connector	Wire Color	Signal Designation/Description
4J5-1	BLU-BRN	D1 / Display BCD / 1J3-1	4J5-6	Key Pin	No Connection
4J5-2	BLU-FED	C1 / Display BCD / 1J3-2	4J5-7	BLU-BLK	C2 / Display BCD / 1J3-7
4J5-3	BLU-ORG	B1 / Display BCD / 1J3-3	4J5-8	BLU-VIO	B2 / Display BCD / 1J3-8
4J5-4	BLU-YEL	A1 / Display BCD / 1J3-4	4J5-9	BLU-GRY	A2 / Display BCD / 1J3-9
4J5-5	BLU-GRN	D2 / Display BCD / 1J3-5			

SYSTEM 11B CPU INTERBOARD SIGNALS

Connector	Wire Color	Signal Designation/Description	Connector	Wire Color	Signal Designation/Description
1J1-1	BRN-GRY	ST-8: Display Digit Strobe / 4J1-1	1J2-1	VIO-GRY	ST-16: Display Digit Strobe / 4J2-1
1J1-2	BRN-VIO	ST-7: Display Digit Strobe / 4J1-2	1J2-2	VIO-BLK	ST-15: Display Digit Strobe / 4J2-2
1J1-3	BRN-BLU	ST-6: Display Digit Strobe / 4J1-3	1J2-3	VIO-BLU	ST-14: Display Digit Strobe / 4J2-3
1J1-4	BRN-GRN	ST-5: Display Digit Strobe / 4J1-4	1J2-4	VIO-GRN	ST-13: Display Digit Strobe / 4J2-4
1J1-5	BRN-YEL	ST-4: Display Digit Strobe / 4J1-5	1J2-5	VIO-YEL	ST-12: Display Digit Strobe / 4J2-5
1J1-6	BRN-ORG	ST-3: Display Digit Strobe / 4J1-6	1J2-6	VIO-ORG	ST-11: Display Digit Strobe / 4J2-6
1J1-7	BRN-FED	ST-2: Display Digit Strobe / 4J1-7	1J2-7	Key Pin	No Connection
1J1-8	Key Pin	No Connection	1J2-8	VIO-RED	ST-10: Display Digit Strobe / 4J2-8
1J1-9	BRN-BLK	ST-1: Display Digit Strobe / 4J1-9	1J2-9	VIO-BRN	ST-9: Display Digit Strobe / 4J2-9
1J3-1	BLU-BRN	D1 / Display BCD / 4J5-1	1J4-1	VIO	Lamp +18V dc Power
1J3-2	BLU-FED	C1 / Display BCD / 4J5-2	1J4-2	VIO	"
1J3-3	BLU-ORG	B1 / Display BCD / 4J5-3	1J4-3	Key Pin	No Connection
1J3-4	BLU-YEL	A1 / Display BCD / 4J5-4	1J4-4	---	No Connection
1J3-5	BLU-GRN	D2 / Display BCD / 4J5-5	1J4-5	---	No Connection
1J3-6	Key Pin	No Connection	1J4-6	---	No Connection
1J3-7	BLU-BLK	C2 / Display BCD / 4J5-7	1J4-7	---	No Connection
1J3-8	BLU-VIO	B2 / Display BCD / 4J5-8	1J4-8	VIO	Lamp +18V dc Power
1J3-9	BLU-GRY	A2 / Display BCD / 4J5-9	1J4-9	VIO	"
1J3-10	---	No Connection			
1J3-11	---	No Connection	1J6-1	RED-BRN	Lamp Row 1 (Q80) / 2J3-18
1J3-12	---	No Connection	1J6-2	RED-BLK	Lamp Row 2 (Q81) / 2J3-17
			1J6-3	RED-ORG	Lamp Row 3 (Q82) / 2J3-16
1J5-1	---	No Connection	1J6-4	Key Pin	No Connection
1J5-2	Key Pin	No Connection	1J6-5	RED-YEL	Lamp Row 4 (Q83) / 2J3-15
1J5-3	BLK	Ground (Lamp Ckt)	1J6-6	RED-GRN	Lamp Row 5 (Q84) / 2J3-14
1J5-4	BLK	Ground (Lamp Ckt)	1J6-7	RED-BLU	Lamp Row 6 (Q85) / 2J3-13
1J5-5	---	No Connection	1J6-8	RED-VIO	Lamp Row 7 (Q86) / 2J3-12
1J5-6	---	No Connection	1J6-9	RED-GRY	Lamp Row 8 (Q87) / 2J3-11
1J5-7	---	No Connection			
1J5-8	BLK	Ground (Lamp Ckt)	1J8-1	GRN-BRN	Switch Col 1 (Q45) / 2J1-18
1J5-9	BLK	Ground (Lamp Ckt)	1J8-2	GRN-FED	Switch Col 2 (Q49) / 2J1-17
			1J8-3	GRN-ORG	Switch Col 3 (Q44) / 2J1-16
1J7-1	YEL-BRN	Lamp Col 1 (Q85/86) / 2J3-8	1J8-4	GRN-YEL	Switch Col 4 (Q48) / 2J1-15
1J7-2	YEL-FED	Lamp Col 2 (Q83/84) / 2J3-7	1J8-5	GRN-BLK	Switch Col 5 (Q43) / 2J1-14
1J7-3	YEL-ORG	Lamp Col 3 (Q81/82) / 2J3-6	1J8-6	Key Pin	No Connection
1J7-4	YEL-BLK	Lamp Col 4 (Q89/90) / 2J3-5	1J8-7	GRN-BLU	Switch Col 6 (Q47) / 2J1-13
1J7-5	Key Pin	No Connection	1J8-8	GRN-VIO	Switch Col 7 (Q42) / 2J1-12
1J7-6	YEL-GRN	Lamp Col 5 (Q57/58) / 2J3-4	1J8-9	GRN-GRY	Switch Col 8 (Q46) / 2J1-11
1J7-7	YEL-BLU	Lamp Col 6 (Q85/86) / 2J3-3			
1J7-8	YEL-VIO	Lamp Col 7 (Q83/84) / 2J3-2	1J9	Not Applicable	
1J7-9	YEL-GRY	Lamp Col 8 (Q81/82) / 2J3-1			
1J10-1	WHT-GRY	Switch Row 8 / 2J1-8	1J11-1	GRY-BRN	Solenoid 1 (Q33) / 5J1-9
1J10-2	WHT-VIO	Switch Row 7 / 2J1-7	1J11-2	Key Pin	No Connection
1J10-3	WHT-BLU	Switch Row 6 / 2J1-6	1J11-3	GRY-FED	Solenoid 2 (Q25) / 5J1-7
1J10-4	Key Pin	No Connection	1J11-4	GRY-ORG	Solenoid 3 (Q32) / 5J1-6
1J10-5	WHT-GRN	Switch Row 5 / 2J1-5	1J11-5	GRY-YEL	Solenoid 4 (Q24) / 5J1-5
1J10-6	WHT-YEL	Switch Row 4 / 2J1-4	1J11-6	GRY-GRN	Solenoid 5 (Q31) / 5J1-4
1J10-7	WHT-ORG	Switch Row 3 / 2J1-3	1J11-7	GRY-BLU	Solenoid 6 (Q23) / 5J1-3
1J10-8	WHT-ORG	Switch Row 3 / 2J1-3	1J11-8	GRY-VIO	Solenoid 7 (Q30) / 5J1-2
1J10-9	WHT-FED	Switch Row 2 / 2J1-2	1J11-9	GRY-BLK	Solenoid 8 (Q22) / 5J1-1
1J11-1	WHT-BRN	Switch Row 1 / 2J1-1			
1J12-1	BRN-BLK	Solenoid 9 (Q17) / 5J2-9	1J13-1	BLK	Solenoid Ground / 5J10-1
1J12-2	BRN-FED	Solenoid 10 (Q9) / 5J2-8	1J13-2	BLK	" / 5J10-2
1J12-3	Key Pin	No Connection	1J13-3	BLK	" / 5J10-3
1J12-4	BRN-ORG	Solenoid 11 (Q16) / 5J2-6	1J13-4	BLK	" / 5J10-4
1J12-5	BRN-YEL	Solenoid 12 (Q8) / 5J2-5			
1J12-6	BRN-GRN	Solenoid 13 (Q15) / 5J2-4	1J14-1	BLK-FED	Memory Protect / 7J1-4
1J12-7	BRN-BLU	Solenoid 14 (Q7) / 5J2-3	1J14-2	WHT	Ground / 7J1-3
1J12-8	BRN-VIO	Solenoid 15 (Q14) / 5J2-2	1J14-3	GRN	ADVANCE Switch / 7J1-1
1J12-9	BRN-GRY	Solenoid 16 (Q6) / 5J2-1	1J14-4	BLU	AUTOMANUAL Switch / 7J1-2
1J16-1	FED	Volume Control Input / 11J1-1	1J17-1	BLK	Ground / 3J1-2
1J16-2	BLK	Volume Control Output / 11J1-2	1J17-2	BLK	" / 3J1-3
1J16-3	Key Pin	No Connection	1J17-3	BLK	" / 3J1-4
1J16-4	White	Signal Ground - CPU / 11J1-4	1J17-4	GRY	Power: +5V dc / 3J1-8
			1J17-5	GRY	" / 3J1-6
			1J17-6	GRY	" / 3J1-9
1J18-1	---	No Connection	1J17-7	Key Pin	No Connection
1J18-2	---	"	1J17-8	BLK-WHT	Power: -12V dc Unreg / 3J1-14
1J18-3	---	"	1J17-9	WHT-GRY	Power: +12V dc Unreg / 3J1-12
1J18-4	---	"			
1J18-5	---	"	1J19-1	ORG-VIO	Flipper Ground / 2J5-5
1J18-6	Key Pin	"	1J19-2	ORG-GRY	Flipper Ground / 2J5-4
1J18-7	---	"	1J19-3	BLU-ORN	Spl Solnd 3 (Q73) / 5J3-3
1J18-8	---	"	1J19-4	BLU-RED	Spl Solnd 2 (Q71) / 5J3-6
1J18-9	---	"	1J19-5	Key Pin	No Connection
			1J19-6	BLU-YEL	Spl Solnd 4 (Q69) / 5J3-4
1J21	Ribbon Cable	to Sound Overlay Lamp Brd. J2	1J19-7	BLU-BRN	Spl Solnd 1 (Q75) / 5J3-7
1J22	Ribbon Cable	to Master Display Board 4J3	1J19-8	BLU-GRN	Spl Solnd 5 (Q77) / 5J3-2
			1J19-9	BLU-BLK	Spl Solnd 6 (Q79) / 5J3-1

Diagnostic Test Flowchart

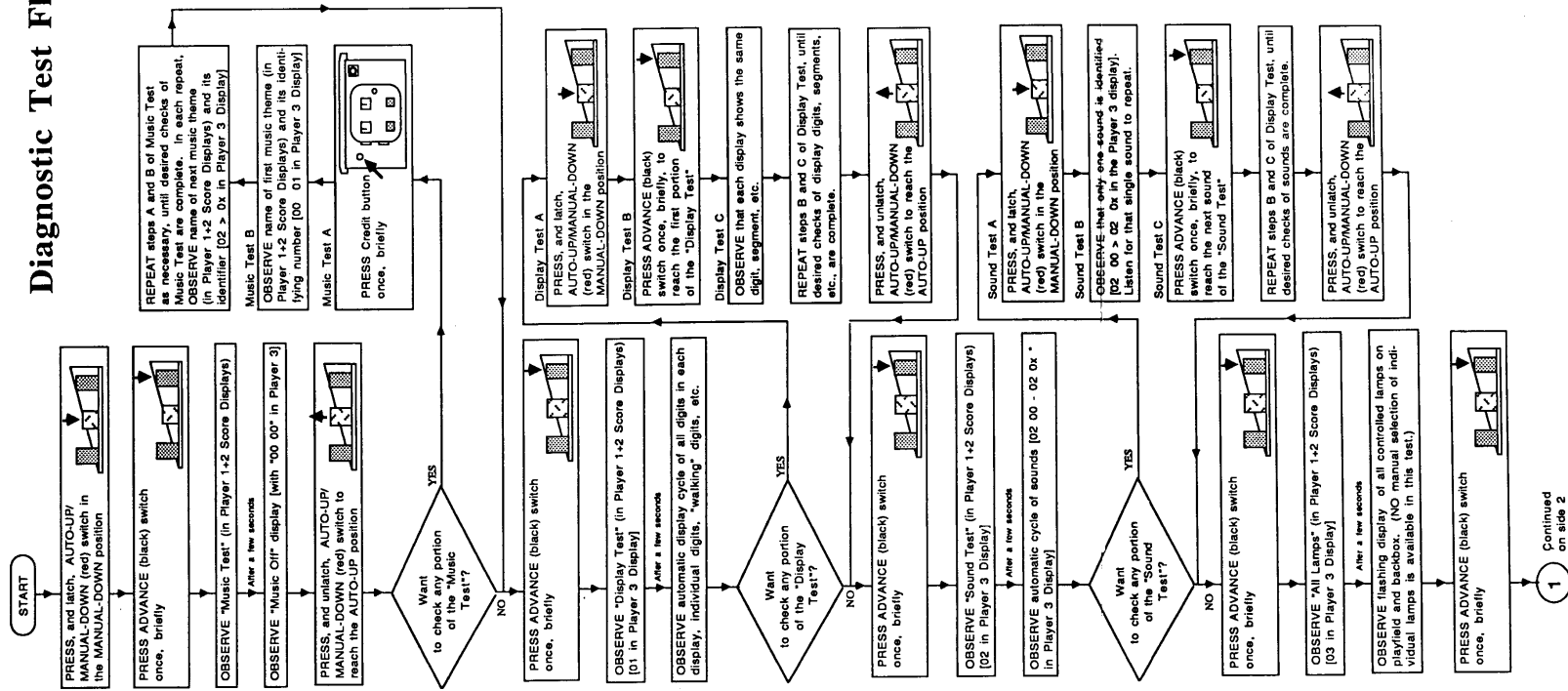

Continued on side 2

Diagnostic Test Flowchart Side 2

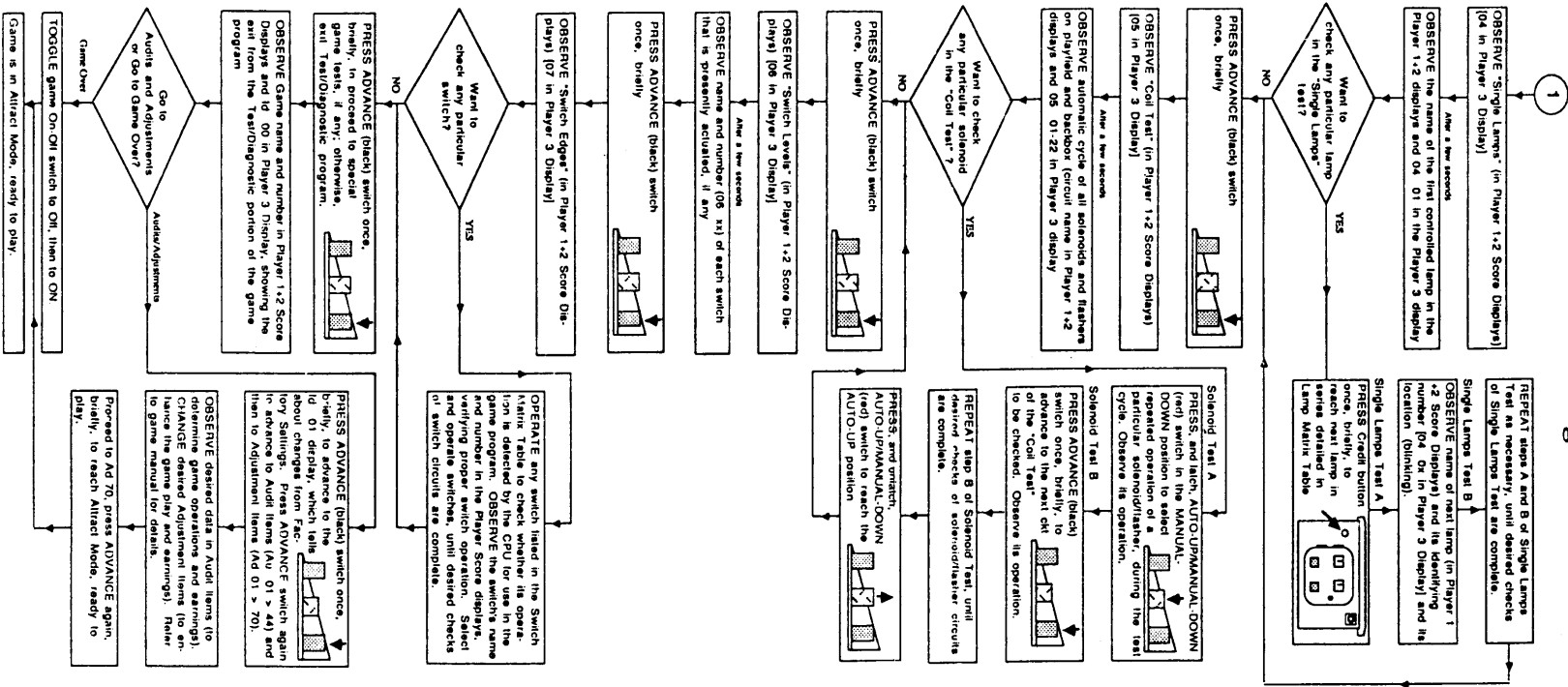

GAME SHOW Switch Matrix

<i>column</i>	1 Q45	2 Q49	3 Q44	4 Q48	5 Q43	6 Q47	7 Q42	8 Q46
<i>row</i>	GRN-BRN 1J8-1	GRN-RED 1J8-2	GRN-ORN 1J8-3	GRN-YEL 1J8-4	GRN-BLK 1J8-5	GRN-BLU 1J8-7	GRN-VIO 1J8-8	GRN-GRY 1J8-9
1 WHT-BRN 1J10-9	Plumb Bob Tilt 1	Not 9	Top Lane, Left 17	Easy Spin 25	Prize Letter T in TRUCK 33	Spin Wheel 41	Not Used 49	Right Flipper 57
2 WHT-RED 1J10-8	Not Used 2	Outhole 10	Top Lane, Middle 18	Center Ramp 26	Prize Letter R in TRUCK 34	Right Spinner 42	Not Used 50	Left Flipper 58
3 WHT-ORN 1J10-7	Credit Button 3	Trough 1, Right 11	Top Lane, Right 19	Prize Letter T in TV 27	Prize Letter U in TRUCK 35	Spot Letter 43	Not Used 51	Not Used 59
4 WHT-YEL 1J10-6	Right Coin 4	Trough 2, Left 12	Right Ramp 20	Prize Letter V in TV 28	Prize Letter C in TRUCK 36	Not Used 44	Not Used 52	Left Jet 60
5 WHT-GRN 1J10-5	Center Coin 5	Not Used 13	Ball Popper 21	Prize Letter T in TRIP 29	Prize Letter K in TRUCK 37	Left Outlane 45	Not Used 53	Right Jet 61
6 WHT-BLU 1J10-3	Left Coin 6	Shooter Lane 14	Not Used 22	Prize Letter R in TRIP 30	Not Used 38	Left Return 46	Not Used 54	Bottom Jet 62
7 WHT-VIO 1J10-2	Stam Tilt 7	Not Used 15	Left Lockup 23	Prize Letter I in TRIP 31	Drop Target Car 39	Right Return 47	Not Used 55	Left Slingshot 63
8 WHT-GRY 1J10-1	High Score Reset 8	Big Bucks 16	Not Used 24	Prize Letter P in TRIP 32	Not Used 40	Right Outlane 48	Not Used 56	Right Slingshot 64

GAME SHOW Lamp Matrix

<i>column</i>	1 Q86	2 Q84	3 Q82	4 Q80	5 Q88	6 Q86	7 Q84	8 Q82
<i>row</i>	YEL-BRN 1J7-1	YEL-RED 1J7-2	YEL-ORN 1J7-3	YEL-BLK 1J7-4	YEL-GRN 1J7-6	YEL-BLU 1J7-7	YEL-VIO 1J7-8	YEL-GRY 1J7-9
1 RED-BRN 1J6-1	Shoot Again 1	Bonus 1K 9	Wheel 5K 17	Wheel 45K 25	TRUCK Letter-T 33	Big Bucks 41	2 Million Left 49	Top Lane Right 57
2 RED-BLK 1J6-2	Wheel 5X 2	Bonus 2K 10	Wheel 10K 18	Wheel 50K 26	TRUCK Letter-R 34	Top Lane Red 42	Left Spot Letter 50	Grand Prize 58
3 RED-ORN 1J6-3	Bonus Multiplier 1X 3	Bonus 4K 11	Wheel 15K 19	TV Letter-T 27	TRUCK Letter-U 35	Top Lane Red 43	Left Extra Ball 51	Collect TV 59
4 RED-YEL 1J6-5	Bonus Multiplier 2X 4	Bonus 8K 12	Wheel 20K 20	TV Letter-V 28	TRUCK Letter-C 36	Back Panel Car 44	2 Million Right 52	Collect Trip 60
5 RED-GRN 1J6-6	Bonus Multiplier 4X 5	Bonus 16K 13	Wheel 25K 21	TRIP Letter-T 29	TRUCK Letter-K 37	Left Extra Ball 45	Right Spot Letter 53	Collect Truck 61
6 RED-BLU 1J6-7	Bonus Multiplier 8X 6	Bonus 32K 14	Wheel 30K 22	TRIP Letter-R 30	Wheel 250,000 38	Wheel 4 Million 46	Right Spinner 54	Collect Car 62
7 RED-VIO 1J6-8	Center Spinner 7	Bonus 64K 15	Wheel 35K 23	TRIP Letter-I 31	Wheel Hold Bonus 39	Wheel Extra Ball 47	Top Lane Left 55	Collect Prizes 63
8 RED-GRY 1J6-9	Center Nudge 8	Bonus 128K 16	Wheel 40K 24	TRIP Letter-P 32	Wheel 1 Million 40	Right Extra Ball 48	Top Lane Middle 56	Right Lock 64

WARNINGS & NOTICES

WARNING

FOR SAFETY AND RELIABILITY, substitute parts and equipment modifications are not recommended.

USE OF NON-BALLY PARTS or circuit modifications may cause injuries or equipment damage.

SUBSTITUTE PARTS OR MODIFICATIONS may void FCC Type Acceptance.

THIS GAME IS PROTECTED by Federal copyright, trademark and patent laws. Unauthorized software or hardware modifications may be illegal under Federal law.

THIS "MODIFICATION" PRINCIPLE ALSO APPLIES to unauthorized facsimiles of BALLY logos, designs, publications, and assemblies. Moreover, facsimiles of BALLY equipment (or any feature thereof) may be illegal under Federal law. Whether or not such facsimiles are manufactured with BALLY components, this rule applies.

WARNING

This equipment generates, uses, and can radiate radio frequency energy, and if not installed and used in accordance with the instructions manual, may cause interference to radio communications. It has been tested and found to comply with the limits for a Class A computing device pursuant to Subpart J of Part 15 of FCC Rules, which are designed to provide reasonable protection against such interference when operated in a commercial environment. Operation of this equipment in a residential area is likely to cause interference in which case the user at his own expense will be required to take whatever measures may be required to correct the interference.

WARNING

Transport this game **ONLY** with hinged backbox down!

WARNING

FCC STICKER. Check the back of your game for an FCC sticker. When BALLY ships a game, the game has been found to comply with FCC Rules. The sticker is proof. If the sticker is missing, legal repercussions to the owner and distributor of the game may result. If your game (manufactured after December 1982) has no FCC sticker, call BALLY for advice. Or write us a note on your game-registration card. Be sure the card bears your game's serial number.

WARNING

THREE-WIRE PLUG. Prevent shock hazard and assure proper game operation! Only plug this game into a properly grounded outlet. **DO NOT** use a "cheater" plug to defeat the power cord's ground pin. **DO NOT** cut off the ground pin.

RF-INTERFERENCE NOTICE

YOUR GAME'S CABLE-HARNES
PLACEMENT and ground-strap routing are very important. They are designed to keep RF radiation and conduction within levels accepted by FCC Regulations.

MAINTAIN THESE LEVELS. Servicing may require that you disconnect harnesses or ground straps. When you're finished, reposition and reconnect them as they were.

NOTICE

MIDWAY and GAME SHOW are trademarks and BALLY, a trade name, of MIDWAY MANUFACTURING COMPANY. WILLIAMS, LANE-CHANGE, and MULTI-BALL are trademarks of WILLIAMS ELECTRONICS GAMES, INC. Entire contents of this manual (c) 1989 MIDWAY MANUFACTURING COMPANY, Manufacturers of BALLY Amusement Games. All rights reserved.