

Williams[®]

Instruction Manual

JOUST[™]

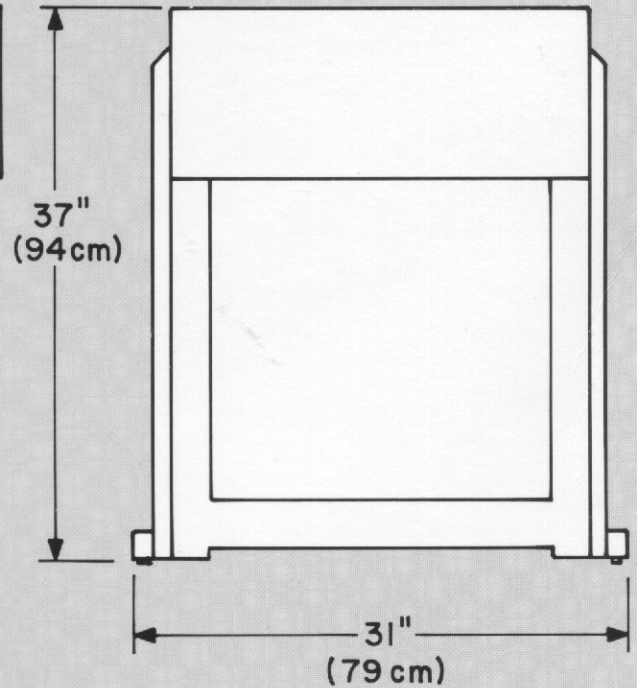

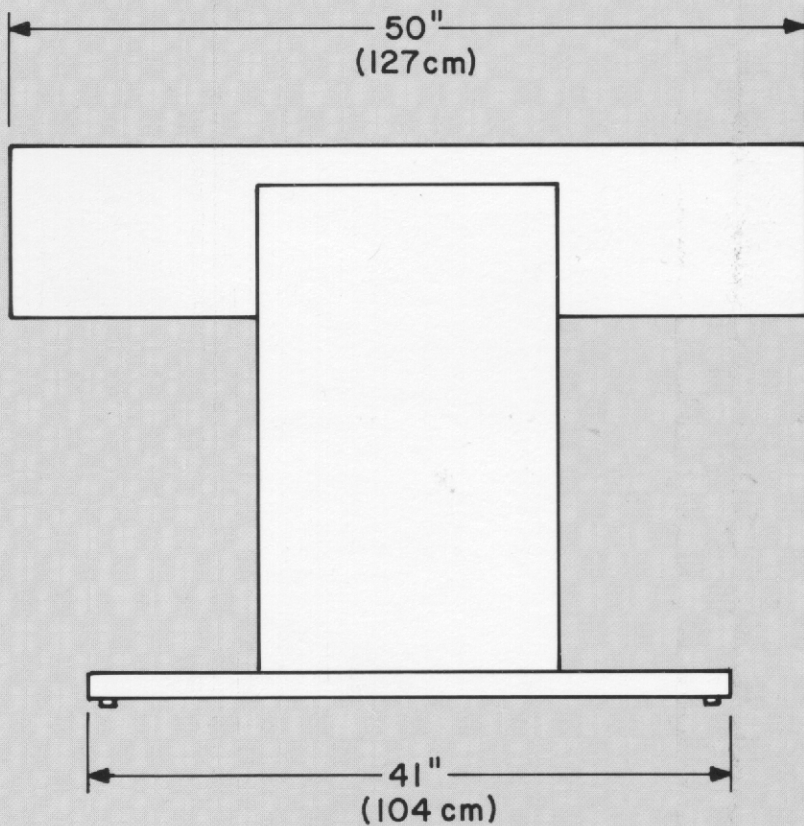

Weight

215 lbs. (97.5 kg.) uncrated
230 lbs. (104 kg.) crated

POWER REQUIREMENTS

115/230VAC Nominal, 50/60Hz
@ 4/2 A Peak 290W

Normal Line = 98-126VAC
196-252VAC

Low Line* = 88-113VAC
176-226VAC

*Transformer jumpers required. See service manual.

ENVIRONMENT

Operating Temperature
0° to +45° C ambient
(+32° to +113° F)

Storage Temperature
-40° to +65° C ambient
(-40° to +149° F)

90% RH at 40° C (104° F),
non-condensing

Specifications subject to change without notice.

NOTICE: "JOUST" is a trademark of Williams Electronics, Inc.

Warning—This equipment generates, uses, and can radiate radio frequency energy and if not installed and used in accordance with the instructions manual, may cause interference to radio communications. It has been certified to comply with the limits for a Class A computing device pursuant to Subpart J of Part 15 of FCC Rules, which are designed to provide reasonable protection against such interference when operated in a commercial environment. Operation of this equipment in a residential area is likely to cause interference in which case the user at his own expense will be required to correct the interference.

SERVICE

For the back-up that keeps you out-front, call Williams toll-free at 800/621-1253. In Illinois, call toll-free at 800/572-1324.

Williams 
ELECTRONICS, INC.

3401 N. California Ave., Chicago, IL 60618
(312) 267-2240, Telex 253095

SPECIAL CONSIDERATIONS WHEN REPLACING CIRCUIT BOARDS

CPU Board

1. Revision level 7 CPU Boards (batteries located on lower left corner at board) of later boards must be used.
2. Must be equipped with blue-labeled Flipper ROMs and blue-labeled Game ROMs.
3. Jumpers W3, W10, W11, W14, W17, W19, W20, and W22 must be connected. Jumpers W4, W9, W12, W15, W16, W18, W21, and W23 must be removed. With the exception of W25, (Factory Setting Jumper) all other jumpers are not changed.

Driver Board

Must be equipped with zero-ohm resistors or wire jumpers (W9-W16) in place of switch matrix drive series resistors R204-R211.

Sound Board

Must be jumpered for ROM operation and be equipped with Joust Pin Sound ROM. (Jumpers W2, W5, W7, W9, W10, W12, and W15 connected; W3, W4, W6, W8, W11, and W13 removed).

Power Supply Board

1. Model D 8345 board required (equipped with relay).
2. Fuse F4 (20A) for flipper solenoids must be installed.

Display Boards

Model C 8363 Master Display and 7-digit Slave Displays required.

GAME OPERATION

Game Over Mode - Turn game ON; player 1 and 2 score shows 00; all player scores alternate the high score to date, Game Over lamp lights. All playfield lamps cycle in attract mode.

Credit Posting - Insert coins; sound produced, number of credits displayed. If maximum credits* exceeded by coin or high score to date, credits posted correctly and coin lockout de-energizes until remaining credits are below maximum. No credits may be won and coins are rejected while the coin lockout is de-energized.

Game Start (2 Player) - Two balls must be positioned on both player ball ramp switches before game will start. For a 2-player game, press 2-player start; credit display reduced by 2, and game goes into standby mode. Press any flipper button and 1 ball is automatically served and put into play for each player. Each drained ball reduces that players ball count and another ball is put into play for opposing player, maintaining 2 balls on playfield during normal play.

Game Start (1 Player) - For 1 player game press 1 player start and game goes into standby mode. Press either player 1 flipper button and 1 ball is put into play and all 4 flippers are controlled with double flipper button action. Playfield features are nearly identical to a two player game with both sides having independent bonus features. Achieving Unlimited Ball feature by making disappearing target lane prevents drains from being counted on both sides of playfield.

Bonus - The egg bonus can be advanced from 1 to 63 (thousand). The disappearing target lane front target scores 3 advances, rear target 5 advances, and lane rollover 8 advances. The right drop targets score 1 advance or lit value. Lighting the 1, 2, and 3 hunter lamps scores 3 advances first time and 5 the second. The eject hole scores 1 advance first time and lit value subsequently. The left drop targets advance bonus multiplier (2x, 3x, 5x). Lighting 5x or making eject with 50K lit lights left targets to collect egg bonus on both players 1 and 2. Only the first player to complete their bank collects their bonus and both targets banks and bonus are reset. Bonus is also collected at end of game.

Eject Hole - Making eject hole advances eject value (20K, 30K, 50K). Making the eject with 50K lit, lights left targets for collect egg bonus.

Drop Target - The right bank drop target value sequences until first target is hit. Completing bank scores lit value unless opposing player completes his right bank first, which resets both players right banks.

Hunter Lamps - Lighting the 1, 2 and 3 hunter lamps advances hunter value lamps (50,000-50 adv., Extra Ball) and disappearing target lane value. Lighting 1, 2 and 3 with extra ball lit, adds 1 ball to amount shown on display.

Disappearing Targets - Hitting front target lights spinner for 1,000 and rear target lights 5,000. Making target lane rollover at anytime turns off opposing players spinner. With any value lit, it scores lane value (40K, 80K, 160K, 320K) and initiates Unlimited Ball. This occurs for 15 seconds when 40K, 80K or 160K is scored and 30 seconds for 320K. Number of seconds is shown in credit display. During this feature all balls are shot into play and drained balls will not be counted against the player that won the feature, but will be counted against the opposite player.

Unlimited Balls - Play continues until both players drain all balls. Then all balls are shot into play to initiate unlimited balls for 30 seconds.

End of Game - When unlimited ball time runs out, both players collect any bonus, match digits* appear in ball in play display, credit* awarded for match. Exceeding high score to date awards three* credits. Match, High Score to Date, and Game Over sounds made as appropriate, and ball shooters automatically balance 2 balls on each side of playfield.

*Indicates game program adjustable features.

INSTALLATION (Refer to Figure 1.)

1. Remove keys from envelope taped to coin door and unlock Player 1 and 2 circuit board access doors. To open doors, hold door securely and press on safety clip at point A, Figure 1, and lower door.
2. Insert line cord through hole in bottom of cabinet on Player 1 side. DO NOT PLUG IN AT THIS TIME.

INSPECTION

1. Push on all connectors and check for loose wire termination on CPU, Driver, Power Supply, and Sound Boards. Check termination on transformer input connector, capacitor, and bridge rectifiers on bottom of cabinet. Reseat any loose wires by pushing in on termination.
2. Gently press on all socketed IC packages on CPU and Sound Boards.
3. Check that two fuses on Sound Board and seven fuses on Power Supply Board are secure.
4. Check that line fuse in bottom of cabinet is secure.
5. Open coin door and check coin door connector for loose wire termination. Reseat any loose wires by pushing in on termination.
6. Close circuit board access doors and open Player 1 and 2 trunk latch access doors.

CAUTION:

DAMAGE MAY OCCUR IF CIRCUIT BOARD ACCESS DOORS ARE OPENED OR CLOSED WITH TRUNK LATCH ACCESS DOORS OPENED. THERE IS NO CLEARANCE BETWEEN OPENED DOORS.

WARNING:

HIGH VOLTAGE TO DISPLAYS IS PRESENT IN PLAYER 2 TRUNK LATCH AREA. POWER SHOULD BE OFF WHEN ACCESSING THIS AREA IN THE FOLLOWING STEP.

7. Reach through trunk latch access door and release the 3 trunk latches securing molding on each side and remove Player 1 and 2 moldings.
8. Remove playfield glass and lift Player 1 side of playfield. Position Player 1 left and right playfield supports (the pair that rotate towards you) and secure playfield in raised position.
9. Check playfield, cabinet, and display connectors for loose wire termination and push on connectors attached to displays.

10. Check that the playfield WHT-RED solenoid ground lead is secured with wingnut to cabinet ground braid.
11. Lower playfield and supports to original position and proceed with Power Turn-On and Game Setup.

POWER TURN-ON AND GAME SETUP

This machine MUST BE PLUGGED INTO A PROPERLY GROUNDED OUTLET to PREVENT SHOCK HAZARD and to ensure PROPER GAME OPERATION. DO NOT use a "cheater" plug to defeat the ground pin on line cord, and DO NOT cut off ground pin. Line voltage MUST agree with that specified on the back of cabinet or serious damage to machine could occur. For low-line applications (105 or 210V ac), refer to the power wiring diagram.

1. With the coin door closed, plug game in and turn it ON. Game should come on in Game Over mode as indicated by Players score reading zero, Game Over light lit, and High Score to Date alternating with player scores.
2. If game comes on in the Diagnostic Mode (Credits display showing 04, Ball in Play Display showing 00, and Player 1 display showing game identification) turn game OFF and ON again.
3. If game now comes on in Game Over mode, bookkeeping and game evaluation totals have been reset to zero.
4. If game still comes on in Diagnostic Mode, open coin door and turn game OFF, and ON twice. This is an indication of batteries being removed with power OFF or coming loose during shipment. This has also resulted in features reverting to factory settings. Any changes from factory settings must be re-entered using procedures provided in Instruction booklet.
5. If game still comes on in Diagnostic Mode perform the CPU Board self-test explained on page 12.
6. Remove package from cash box and place four balls on playfield next to outholes.
7. Perform diagnostic tests and make any desired changes to features as described later in this manual.

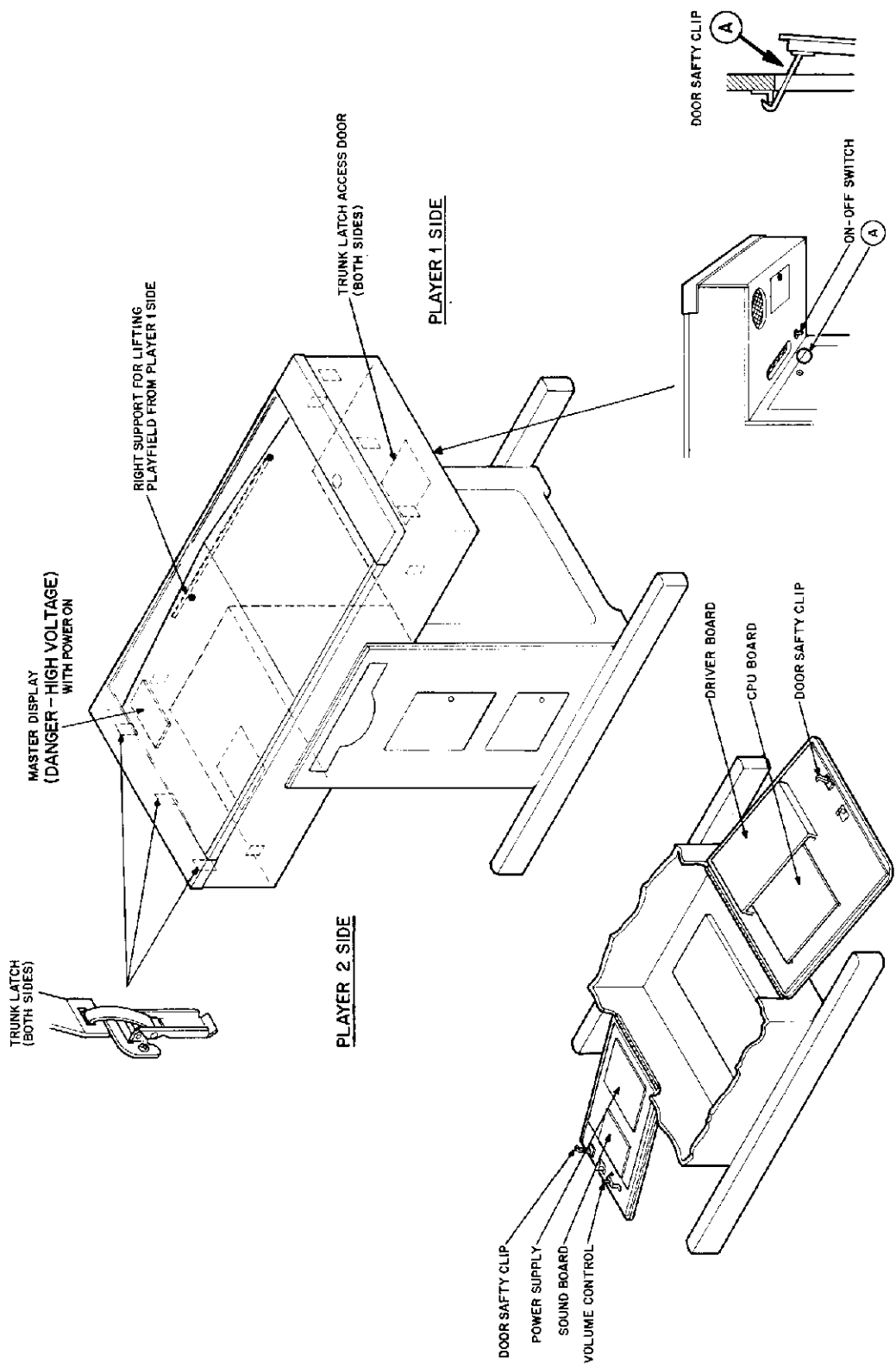

Figure 1. Installation Details

BOOKKEEPING AND GAME EVALUATION

(Functions 01-17)

1. Set AUTO-UP/MANUAL-DOWN switch to AUTO-UP and depress ADVANCE pushbutton. Test 04 is indicated in the Player 1 credits display, Function 00 in Player 1 Match display, and Game Identification in Player 1 score display.
2. Operate the ADVANCE pushbutton to display Functions 01 thru 04 on the Player 1 Match display (See Table 1) and record the corresponding totals (number of coins and total paid credits) from the Player 1 score display. (To review a total that has been advanced past, set switch to MANUAL-DOWN and operate the ADVANCE pushbutton).
3. Operate the ADVANCE pushbutton to display Functions 05, 06, and 07 in the Player 1 Match display and record the corresponding free credit totals from the Player 1 score display.
4. Operate the ADVANCE pushbutton to display Function 08 in the Player 1 Match display. Total credits is indicated in the Player 1 score display, total free credits in the Player 2 credit display, and percentage of free credits in the Player 2 score display.
5. Operate the ADVANCE pushbutton to display Function 09 thru 12 in the Player 1 Match display and record the corresponding totals from the Player 1 score display.

6. Operate the ADVANCE pushbutton to display Functions 13 thru 17 in the Player 1 Match display and record the corresponding totals from the Player 2 credit display.
7. With switch set to MANUAL-DOWN operate ADVANCE to display Function 50 in the Player 1 Match Display. From Function 50 you can return to game over or zero audit totals and return to game over. Perform step 8.a. or 8.b. as desired.
8.
 - a. To return to game over, set the switch to AUTO-UP and depress ADVANCE.
 - b. **To zero audit totals** and return to game over set switch to AUTO-UP, operate the credit button to display 35 in the Player 1 score display, and depress ADVANCE.

GAME ADJUSTMENT PROCEDURE

(Functions 13-41)

Coin door must be open to change settings.

1. Set AUTO-UP/MANUAL-DOWN switch to AUTO-UP and depress the ADVANCE pushbutton. Test 04 is indicated in the Player 1 Credits display, Function 00 in Player 1 Match display, and game identification in Player 1 score display.
2. **To raise** Function number in Player 1 Match display, operate ADVANCE pushbutton with switch set to AUTO-UP. **To lower** Function number, operate ADVANCE with switch set to MANUAL-DOWN.

Table 1. Audit Totals

FUNCTION	DESCRIPTION		
	PLAYER 1 SCORE DISPLAY	PLAYER 2 CREDIT DISPLAY	PLAYER 2 SCORE DISPLAY
00	Game Identification (2519 1)	—	—
01	Coins, Left chute (closest to coin door hinge)	—	—
02	Coin, center chute	—	—
03	Coin, right chute	—	—
04	Total Paid Credits	—	—
05	Special Credits	—	—
06	Replay Score Credits	—	—
07	Match Credits	—	—
08	Total Credits	Free Credits	%Free Credits
09	Total Extra Balls	—	—
10	Ball Time in Minutes	—	—
11	Total Balls Played	—	—
12	Current High Score to Date	—	—
13	Backup High Score to Date	High Score to Date	—
14	Replay 1 Score	Credits Awarded	—
15	Replay 2 Score	Times exceeded	—
—	Replay 3 Score	Times exceeded	16
17	Replay 4 Score	Times exceeded	—

3. With desired Function indicated in Player 1 Match display, **raise** value in player 1 score display by operating credit button with switch set to AUTO-UP; **lower** value by operating credit button with switch set to MANUAL-DOWN. Value left in Player 1 score display is the new setting. For values see Table 2, and for pricing Table 3.
4. Repeat steps 2 and 3 until all required adjustments have been made.
5. Operate ADVANCE until Function 50 is indicated in Player 1 Match display. From Function 50 you can return to game over or **restore factory settings**. Perform step 6 or 7 as desired.
6. To return to game over, depress ADVANCE with switch set to AUTO-UP.
7. To restore factory settings **and** zero audit totals:
 - a. Operate Credit button with switch set to AUTO-UP

- until 45 is indicated in Player 1 score Display.
- b. Depress ADVANCE. The game returns to Test 04, Function 00.
- c. Set switch to MANUAL-DOWN and depress ADVANCE to indicate Function 50.
- d. Set switch to AUTO-UP and depress ADVANCE.

RESETTING HIGH SCORE TO DATE

1. Using game adjustment procedure, set Function 13 to the desired reset value.
2. Depress HIGH SCORE RESET pushbutton.

FACTORY AUDIT TOTALS

(Functions 42-49)

The factory audit functions are not assigned.

Table 2. Game Adjustments

FUNCTION	DESCRIPTION	NOTES	*FACTORY SETTING
13	Backup High Score to Date (HSTD Credits Awarded)	1	2,500,000
14	Replay 1 Score [Times exceeded]	2	1,000,000
15	Replay 2 Score [Times exceeded]	2	2,000,000
16	Replay 3 Score [Times exceeded]	2	0
17	Replay 4 Score [Times exceeded]	2	0
18	Maximum Credits	3	30
19	Standard and Custom Pricing Control	4	01/02
20	Left Coin Slot Multiplier	4	01/09
21	Center Coin Slot Multiplier	4	04/45
22	Right Coin Slot Multiplier	4	01/18
23	Coin Units Required for Credit	4	02/05
24	Coin Units Bonus Point	4	04/45
25	Minimum Coin Units	4	00
26	Match: 00 = Match ON; 01 = Match OFF	-	00
27	Not Used	-	00
28	Replay Scores: 00 = Awards Credit; 01 = Awards Extra Ball	-	00
29	Maximum Plumb Bob Tilts	-	03
30	Number of Balls (03 or 05)	-	05
31	Extra Ball Difficulty (Hunter 1-2-3) 00 = 50K not lit initially; 01 = 50K lit initially	-	00
32	Unlimited Ball Difficulty (Disappearing Target Lane) 00 = "40" not lit initially; 01 = "40" lit initially	-	00
33	Right 3-Bank Scoring: 00 = 30K to 200K; 01 = 50K to 200K	5	00
34-39	Not Used	-	-
40	High Score Credits	1	03
41	Maximum Extra Balls at one time (00 = No Extra Ball)	-	07

* Second Factory Setting value is with jumper W25 on CPU Board connected.

[] Description in brackets shown in Player 2 Display.

1. Function 13 may be set to any multiple of 100,000 points. Setting Function 40 to zero with Function 13 set to any score but zero permits the High Score to Date feature to operate but no credits are awarded.
2. Functions 14-17 (Replay Scores) may be set to any multiple of 100,000 points. Setting a function to zero disables the replay score point.
3. Setting Maximum Credits (Function 18) to zero places the game in a **free play mode**.

4. With Function 19 set to 00, Functions 20-25 must be set manually. Refer to Table 2 for eight standard pricing schemes (selected by values of 01-08 for Function 19) and custom pricing values. For straight quarter play, set Function 19 to 00, Function 23 to 01 and Function 24 to 00. All other pricing functions should remain at their factory settings.
5. With Function 33 set to "00" (factory) bank lamps sequence from no lit value (30K) thru 200K. With it set to "01", they sequence from 50K thru 200K.

DIAGNOSTIC PROCEDURES

Display Digits Test

1. Set AUTO-UP/MANUAL-DOWN switch to MANUAL-DOWN and depress ADVANCE. Displays should indicate all 0's.
2. Set the switch to AUTO-UP. Displays should sequence from all 0's thru all 9's. Comma segments should come on when odd digits are displayed.
3. To stop cycling, set switch to MANUAL-DOWN. Operate ADVANCE pushbutton to step through the tests one number at a time. Set switch to AUTO-UP to resume cycling.

Sound Test

1. From Display Digits Test depress ADVANCE with the switch set to AUTO-UP. Test 00 should be indicated in the Player 1 Credits display and the Player 1 Match display should sequence from 00 thru 06. Different sounds should be produced for 00, 01, 02, 03, and 04.
2. To continuously pulse a single sound, set the toggle switch to MANUAL-DOWN. Operate ADVANCE pushbutton to sequence through sounds one at a time. Set toggle switch to AUTO-UP to resume sequencing.

Lamp Test

From Sound Test depress ADVANCE with the switch set to AUTO-UP. Test 01 should be indicated in the Player 1 Credits display and all multiplexed lamps should flash.

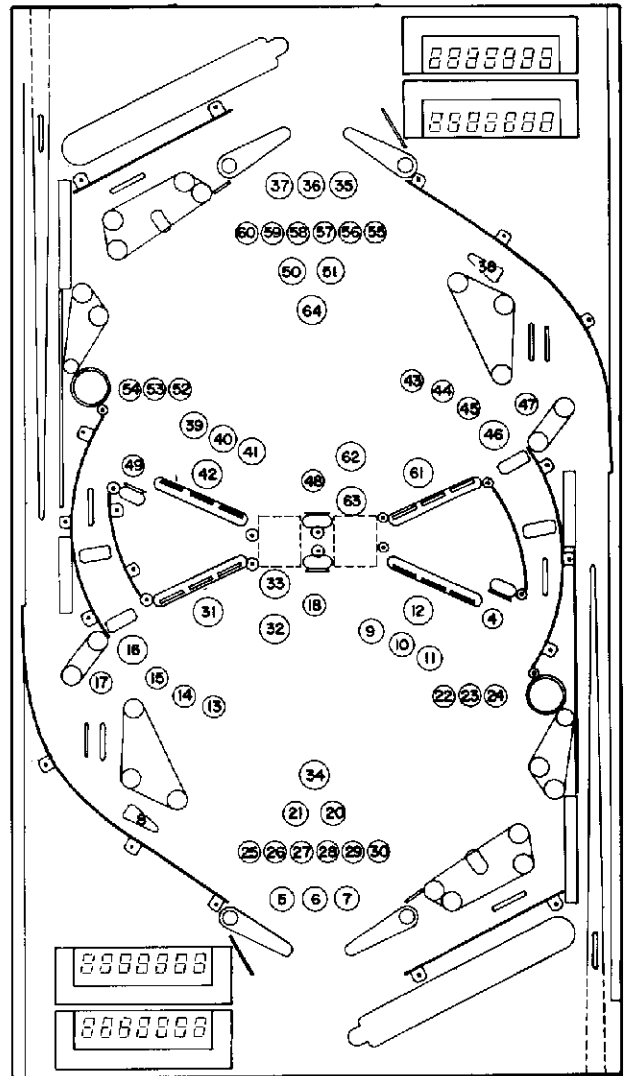
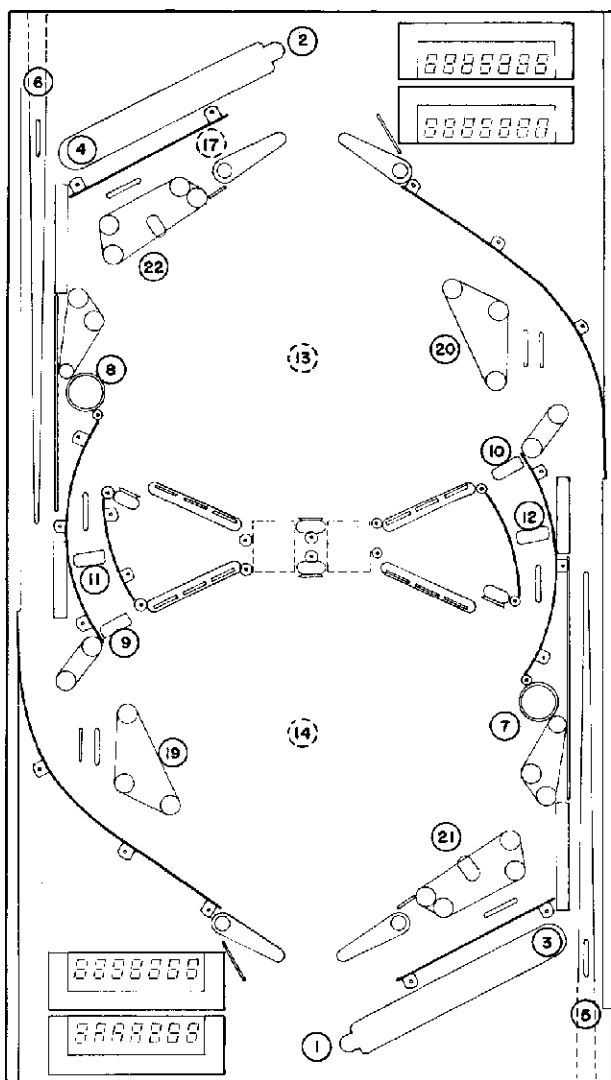

Figure 4. Playfield Lamp Location



Solenoid Test

1. From Lamp Test depress ADVANCE with the switch set to AUTO-UP. Test 02 should be indicated in the Player 1 Credits display. The Player 1 Match display sequences from 01 thru 25. Corresponding solenoids 01 thru 24 are pulsed. Flipper relay is de-energized with subtest 25.
2. To continuously pulse a single solenoid set switch to MANUAL-DOWN. Operate ADVANCE pushbutton sequence through the solenoids one at a time. Set switch to AUTO-UP to resume sequencing.

Sol.

No.	Function
01	Outhole P1
02	Outhole P2
03	Ball Ramp Thrower P1
04	Ball Ramp Thrower P2
05	Ball Shooter P1
06	Ball Shooter P2
07	Eject Hole P1
08	Eject Hole P2
10	Disappearing P1 Target (Front)
09	Disappearing P2 Target (Front)
11	Disappearing P1 Target (Rear)
12	Disappearing P2 Target (Rear)
13	Left 3-Bank Drop Target Reset Relay
14	Right 3-Bank Drop Target Reset Relay
15	General Illumination Relay
16	Coin Lockout
17	Flipper Select Relay
18	Not Used
19	Left Kicker P1
20	Left Kicker P2
21	Right Kicker P1
22	Right Kicker P2

Figure 5. Playfield Solenoid Locations and Solenoid Chart

Table 4. Solenoid Connections

SOL. NO.	FUNCTION	WIRE COLOR	CONNECTIONS	DRIVER TRANS.	SOLENOID PART NO.
01	Outhole P1	GRY-BRN	2P11-4, 8P3-1	Q15	SA3-23-850-DC
02	Outhole P2	GRY-RED	2P11-5, 8P3-2	Q17	SA-23-850-DC
03	Ball Ramp Thrower P1	GRY-ORN	2P11-7, 8P3-3	Q19	SG1-23-850-DC
04	Ball Ramp Thrower P2	GRY-YEL	2P11-8, 8P3-4	Q21	SG1-23-850-DC
05	Ball Shooter P1	GRY-GRN	2P11-9, 8P3-5	Q23	SA-4-23-850-DC
06	Ball Shooter P2	GRY-BLU	2P11-3, 8P3-6	Q25	SA-4-23-850-DC
07	Eject Hole P1	GRY-VIO	2P11-2, 8P3-7	Q27	SG-1-23-850-DC
08	Eject Hole P2	GRY-BLK	2P11-1, 8P3-8	Q29	SG-1-23-850-DC
09	Disappearing P1 Target (Front)	BRN-BLK	2P9-9, 8P3-9	Q31	SA-5-24-750-DC
10	Disappearing P2 Target (Front)	BRN-RED	2P9-7, 8P3-10	Q33	SA-5-24-750-DC
11	Disappearing P1 Target (Rear)	BRN-ORN	2P9-1, 8P3-11	Q35	S-5-24-750-DC
12	Disappearing P2 Target (Rear)	BRN-YEL	2P9-2, 8P3-12	Q37	SA-5-24-750-DC
13	Left 3-Bank Drop Target Reset Relay	BRN-GRN	2P9-3, 8P3-13	Q39	5580-09613-00
14	Right 3-Bank Drop Target Reset Relay	BRN-BLU	2P9-4, 8P3-14	Q41	5580-09613-00
15	General Illumination Relay	BRN-VIO	2P9-5, 3J7-1	Q43	5580-09555-00
16	Coin Lockout	BRN-GRY	2P9-6, 7P4-5	Q45	904218-696
17	Flipper Select Relay	BLU-BRN	2P12-7, 8P3-7, 8P5-8	Q2	5580-09613-00
18	Not Used	BLU-RED	2P12-4	Q4	5580-09384-00
19	Left Kicker P1	BLU-ORN	2P12-3, 19	Q6	SG-1-23-850-DC
20	Left Kicker P2	BLU-YEL	2P12-6, 20	Q8	SG-1-23-850-DC
21	Right Kicker P1	BLU-GRN	2P12-8, 21	Q10	SG-1-23-850-DC
22	Right Kicker P2	BLU-BLK	2P12-9, 22	Q12	SG-2-23-850-DC
	Left Flipper P1	BLU-GRY	7SW73, 7P5-10, 8P3-32	—	SFL-19-400/30-750-DC
	Right Flipper P1	BLU-VIO	7SW72, 7P5-9, 8P3-34	—	SFL-19-400/30-750-DC
	Left Flipper P2	BLK-BLU/BLK-ORN	7SW76, 7P5-12, 8P3-31	—	SFL-19-400/30-750-DC
	Right Flipper P2	BLK-YEL/BLK-GRN	7SW77, 7P5-11, 8P3-33	—	SFL-19-400/30-750-DC

***NOTES:**

1. Second wire color on flippers is between flipper coil and solenoid 17—flipper select relay. Solenoid 17 selects control of player 2 flippers by player 1 or 2. Player 2 flipper connections for 1 player game are as follows:

Left P2—BLK-RED/BLK-ORN—7SW74, 7P5-5, 8P3-23
 Right P2—BLK-WHT/BLK-GRN—7SW75, 7P5-6, 8P3-24

2. Solenoids 13 and 14 pulse ground + 02 drop target banks each

3. Part No. of solenoid 16 is Coin-Co number.

4. Special switch connections for solenoids 19 through 22 are as follows:

19—ORN-BRN—2P13-2, 8P3-26
 20—ORN-YEL—2P13-4, 8P3-27
 21—ORN-GRN—2P13-8, 8P3-28
 22—ORN-BLU—2P12-9, 8P3-29

5. Typical wiring for solenoids and special switches follows.

Switch Test

1. From Solenoid Test depress ADVANCE with the switch set to AUTO-UP. Test 03 should be indicated in the Player 1 Credits display and any stuck switches in the Player 1 Match display. As stuck switch(es) is displayed a sound is produced. The display continuously cycles through the stuck switches and as they are opened, the number is removed from the sequence. When all switches are open, the Player 1 Match display is blank and the sounds stop.
2. If all switches in a row are displayed, first verify that all are open and then check for a short to ground on the row wire.
3. Operate switches; a sound is produced and switch number is momentarily indicated in the ball in play display. If two switches in a row are indicated with one switch closed, check for a short between the column wires; for multiple indication check column wire for short to ground. If two

switches in a column are indicated with one switch closed, check for short between row wires.

4. If proper indications are obtained in Test 03 but matrix problem is suspected in game play, disconnect lamp connectors 2P5 and 2P7. Recheck in game play. Perform CPU Self-Test if problem remains. If problem is cleared, check for short between lamp matrix and switch matrix.
5. Shorted diodes can cause "rectangle" switch matrix problems. For example, consult the switch matrix chart and visualise a situation where the disappearing target switch 42 is down and drop target switch 26 is down. If a ball makes the right 3-bank center drop target switch 27, a shorted diode at switch 26 would cause the disappearing target rollover switch 43 to be indicated. This would falsely initiate Unlimited Ball play. Note that the faulty switch is "diagonally" opposite from the invalidly-indicated switch.

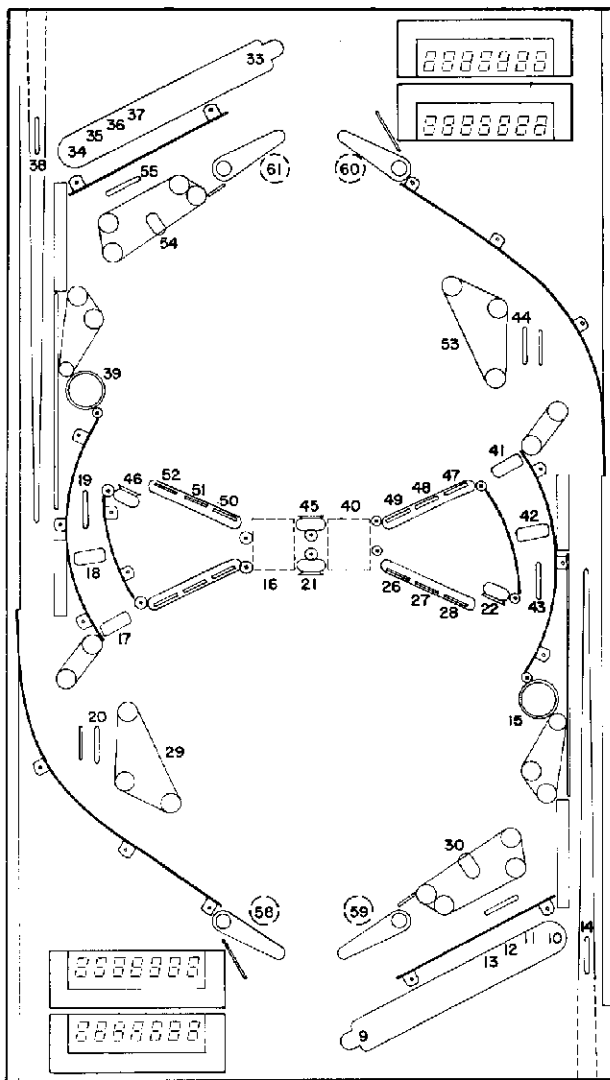

Switch

No. Function* (Score)

- 01 *Plumb bob tilt
- 02 Not Used
- 03 *1-Player Start
- 04 *Right coin chute
- 05 *Center coin chute
- 06 *Left coin chute
- 07 *Slam tilt
- 08 *High score reset
- 09 Outhole
- 10 Ball ramp 1 (Right)
- 11 Ball ramp 2
- 12 Ball ramp 3
- 13 Ball ramp 4 (Left)
- 14 Shooter lane
- 15 Eject Hole (5,000/lit value)
- 16 Spinner (100/lit value)
- 17 Disappearing target (Front) (3,000)
- 18 Disappearing target (Rear) (5,000)
- 19 Disappearing target rollover (8,000 + lit value)
- 20 Hunter rollover 1 (100)
- 21 Hunter bullseye 2 (100)
- 22 Hunter bullseye 3 (100)
- 23 Left 3 bank, Drop target (Left) (1,000)
- 24 Left 3 bank, Drop target (Center) (1,000)
- 25 Left 3 bank, Drop target (Right) (1,000)
- 26 Right 3 bank, Drop target (Left) (1,000)
- 27 Right 3 bank, Drop target (Center) (1,000)
- 28 Right 3 bank, Drop target (Right) (1,000)
- 29 Left kicker (10)
- 30 Right kicker (10)
- 31 Right drain rollover (10,000)
- 32 Not used
- 33 Outhole
- 34 Ball ramp 1 (Right)
- 35 Ball ramp 2
- 36 Ball ramp 3
- 37 Ball ramp 4 (Left)
- 38 Shooter lane
- 39 Eject Hole (5,000/lit value)
- 40 Spinner (100/lit value)
- 41 Disappearing target (Front) (3,000)
- 42 Disappearing target (Rear) (5,000)
- 43 Disappearing target rollover (8,000 + lit value)
- 44 Hunter rollover 1 (100)
- 45 Hunter rollover 2 (100)
- 46 Hunter rollover 3 (100)
- 47 Left 3 bank, Drop target (Left) (1,000)
- 48 Left 3 bank, Drop target (Center) (1,000)
- 49 Left 3 bank, Drop target (Right) (1,000)
- 50 Right 3 bank, Drop target (Left) (1,000)
- 51 Right 3 bank, Drop target (Center) (1,000)
- 52 Right 3 bank, Drop target (Right) (1,000)
- 53 Left kicker (10)
- 54 Right kicker (10)
- 55 Right drain rollover (10,000)
- 56 Not used
- 57 *2-Player Start
- 58 **P1 Left flap
- 59 **P1 Right flap
- 60 **P2 Left flap
- 61 **P2 Right flap

PLAYER 1

PLAYER 2

Note: Score value in parenthesis
 *Switches located in cabinet
 **Switches located on flipper assemblies and only produce sounds.

Figure 6. Playfield Switch Location and Switch List

COLUMN	1 GRN-BRN 2J2-9	2 GRN-RED 2J2-8	3 GRN-ORN 2J2-7	4 GRN-YEL 2J2-6	5 GRN-BLK 2J2-5	6 GRN-BLU 2J2-3	7 GRN-VIO 2J2-2	8 GRN-GRY 2J2-1
1 WHT-BRN 2J3-9	Plumb bob tilt 1	Outhole 9	Disappearing target (Front) 17	Left 3 bank, Drop target (Right) 25	Outhole 33	Disappearing target (Front) 41	Left 3 bank, Drop target (Right) 49	2-Player Start 57
2 WHT-RED 2J3-8	Not Used 2	Ball ramp 1 10	Disappearing target (Rear) 18	Right 3 bank, Drop target (Left) 26	Ball ramp 1 34	Disappearing target (Rear) 42	Right 3 bank, Drop target (Left) 50	P1 Left flap 58
3 WHT-ORN 2J3-7	1-Player Start 3	Ball ramp 2 11	Disappearing target rollover 19	Right 3 bank, Drop target (Center) 27	Ball ramp 2 35	Disappearing target rollover 43	Right 3 bank, Drop target (Center) 51	P1 Right flap 59
4 WHT-YEL 2J3-6	Right coin chute 4	Ball ramp 3 12	Hunter rollover 1 20	Right 3 bank, Drop target (Right) 28	Ball ramp 3 36	Hunter rollover 1 44	Right 3 bank, Drop target (Right) 52	P2 Left flap 60
5 WHT-GRN 2J3-5	Center coin chute 5	Ball ramp 4 13	Hunter bulls-eye 2 21	Left kicker 29	Ball ramp 4 37	Hunter rollover 2 45	Left kicker 53	P2 Right flap 61
6 WHT-BLU 2J3-4	Left coin chute 6	Shooter lane 14	Hunter bulls-eye 3 22	Right kicker 30	Shooter lane 38	Hunter rollover 3 46	Right kicker 54	62
7 WHT-VIO 2J3-3	Slam tilt 7	Eject Hole (5,000/lit value) 15	Left 3 bank, Drop target (Left) 23	Right drain rollover 31	Eject Hole 39	Left 3 bank, Drop target (Left) 47	Right drain rollover 55	63
8 WHT-GRY 2J3-1	High score reset 8	Spinner (100/lit value) 16	Left 3 bank, Drop target (Center) 24	Not used 32	Spinner 40	Left 3 bank, Drop target (Center) 48	Not used 56	64

Player 1

Player 2

Figure 7. Switch Matrix

INITIATING AUTO-CYCLE MODE

1. Set AUTO-UP/MANUAL-DOWN switch to AUTO-UP and depress ADVANCE pushbutton. Test 04 is indicated in Player 1 Credit display and Function 00 in Player 1 Match Display.
2. Set switch to MANUAL-DOWN and depress ADVANCE to indicate Function 50 in the Player 1 Match Display.
3. Set switch to AUTO-UP and operate Credit button to indicate 15 in Player 1 Score Display.
4. Depress ADVANCE pushbutton to start Auto-Cycle mode. Each cycle of this mode sequences thru the Display Digits Test, Sound Test (00), Lamp Test (01), and Solenoid test (02).
5. To terminate the test and return to game over, turn the game OFF and back ON.

CPU BOARD SELF-TEST

Depress the DIAGNOSTIC pushbutton on the left side of the CPU Board. The following indications are provided. With 0 indication the game returns to the game over mode.

- 0 - Test Passed
- 1 - IC13 RAM Faulty
- 2 - IC16 RAM Faulty
- 3 - IC17 ROM 2 Faulty
- 4 - IC17 ROM 2 Faulty
- 5 - IC20 ROM 1 Faulty
- 6 - IC14 Game ROM 1 Faulty
- 7 - IC26 Game ROM 0 Faulty
- 8 - IC19 CMOS RAM or Memory Protect Circuit Faulty
- 9 - Coin-door closed, Memory Protect Circuit Faulty, or IC19 CMOS RAM Faulty.

Note that "0" remaining after power turn-on indicates CPU Board lockup.

NOTE

Cable harness placements and ground strap routing on this game have been designed to keep RF radiation and conduction within levels acceptable to FCC regulations. To maintain these levels, reposition harnesses and reconnect ground straps to their original placements if they should be disconnected during maintenance.

PLAYER 2 ACCESS DOOR

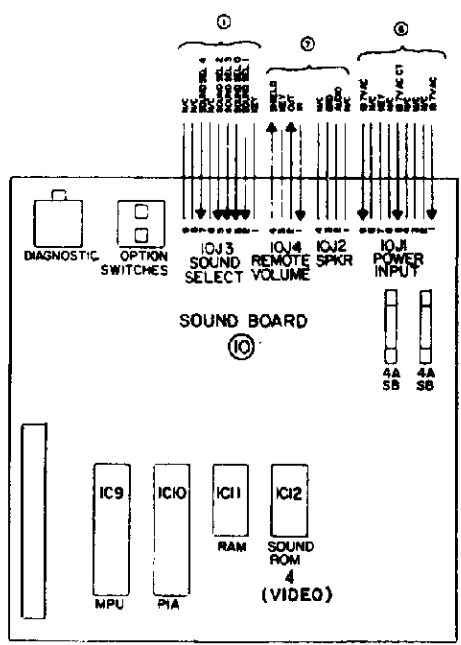

NOTES:

1. CONNECTIONS ARE INDICATED BY CIRCLED NUMBERS AS FOLLOWS:

- ① CPU BOARD
- ② DRIVER BOARD
- ③ POWER SUPPLY BOARD
- ④ MASTER DISPLAY BOARD
- ⑤ SLAVE DISPLAY BOARD
- ⑥ BACKBOX
- ⑦ CABINET
- ⑧ PLAYFIELD
- ⑨ NOT ASSIGNED
- ⑩ SOUND BOARD
- ⑪ NOT ASSIGNED

2. REFER TO POWER WIRING DIAGRAM FOR CONNECTIONS TO 3P1.

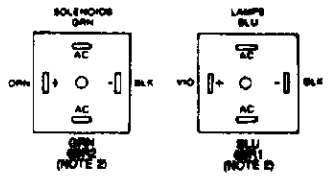
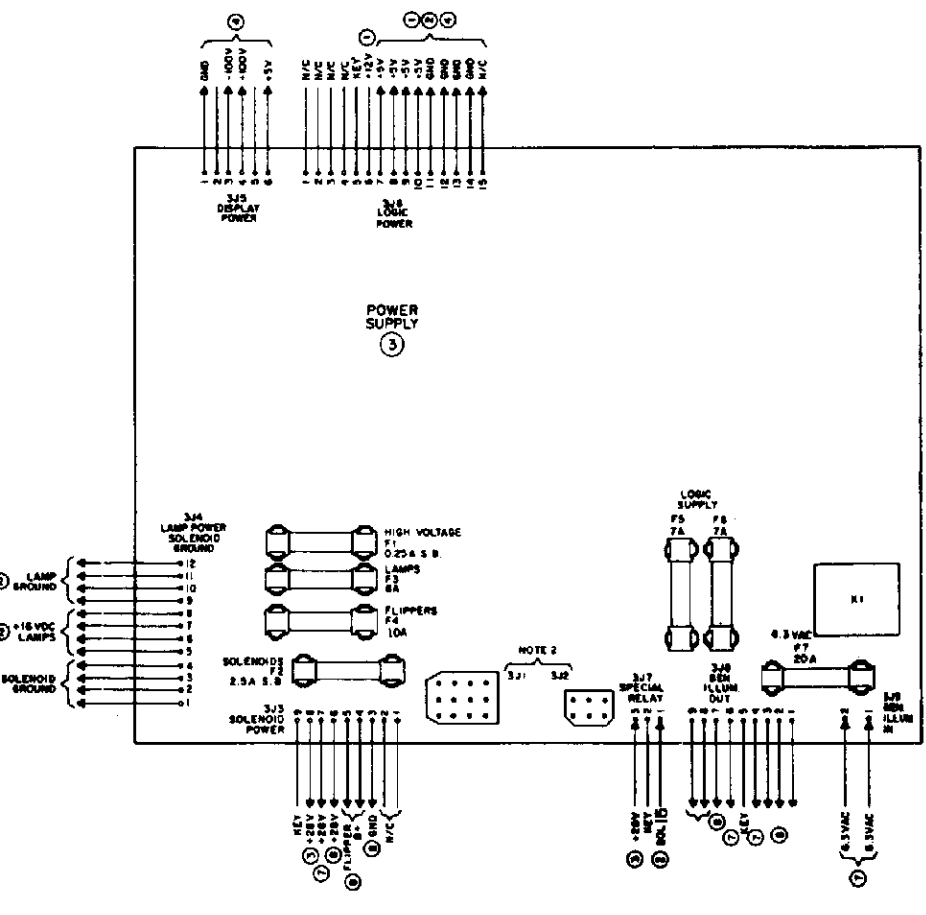

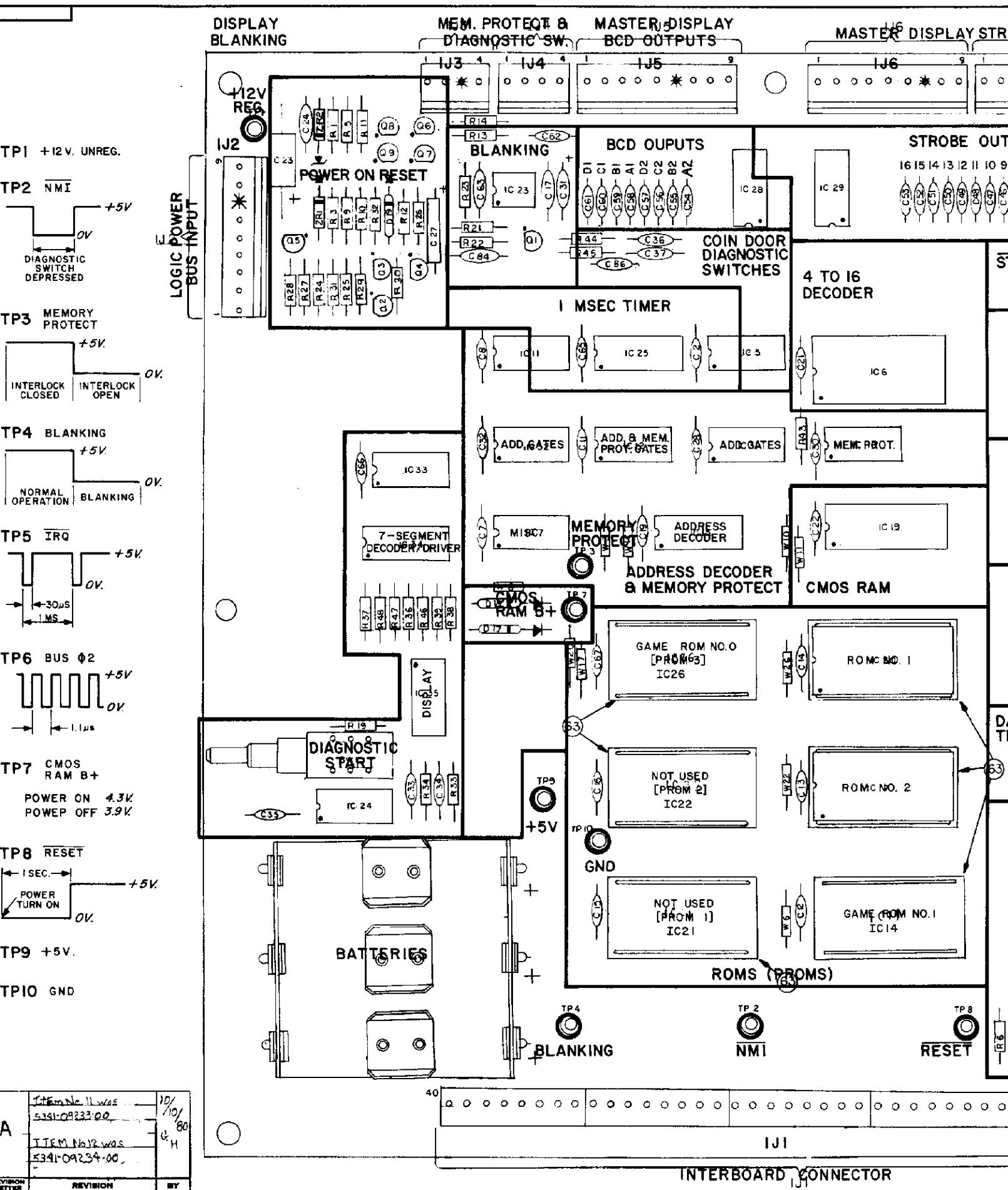

TP1 +12V. UNREG.

TP2 NMI
 +5V
 0V
 DIAGNOSTIC SWITCH DEPRESSED

TP3 MEMORY PROTECT
 +5V.
 INTERLOCK CLOSED INTERLOCK OPEN 0V.

TP4 BLANKING
 +5V.
 NORMAL OPERATION BLANKING 0V.

TP5 IRQ
 +5V.
 0V.
 30µS
 1MS

TP6 BUS Φ2
 +5V
 0V.
 1.1µs

TP7 CMOS RAM B+
 POWER ON 4.3V
 POWER OFF 3.9V

TP8 RESET
 1SEC.
 POWER TURN ON +5V.
 0V.

TP9 +5V.

TP10 GND

Item No. 11 was	10/10/80
5341-09233-00	
Item No. 12 was	H
5341-09234-00	
REVISION LETTER	BY

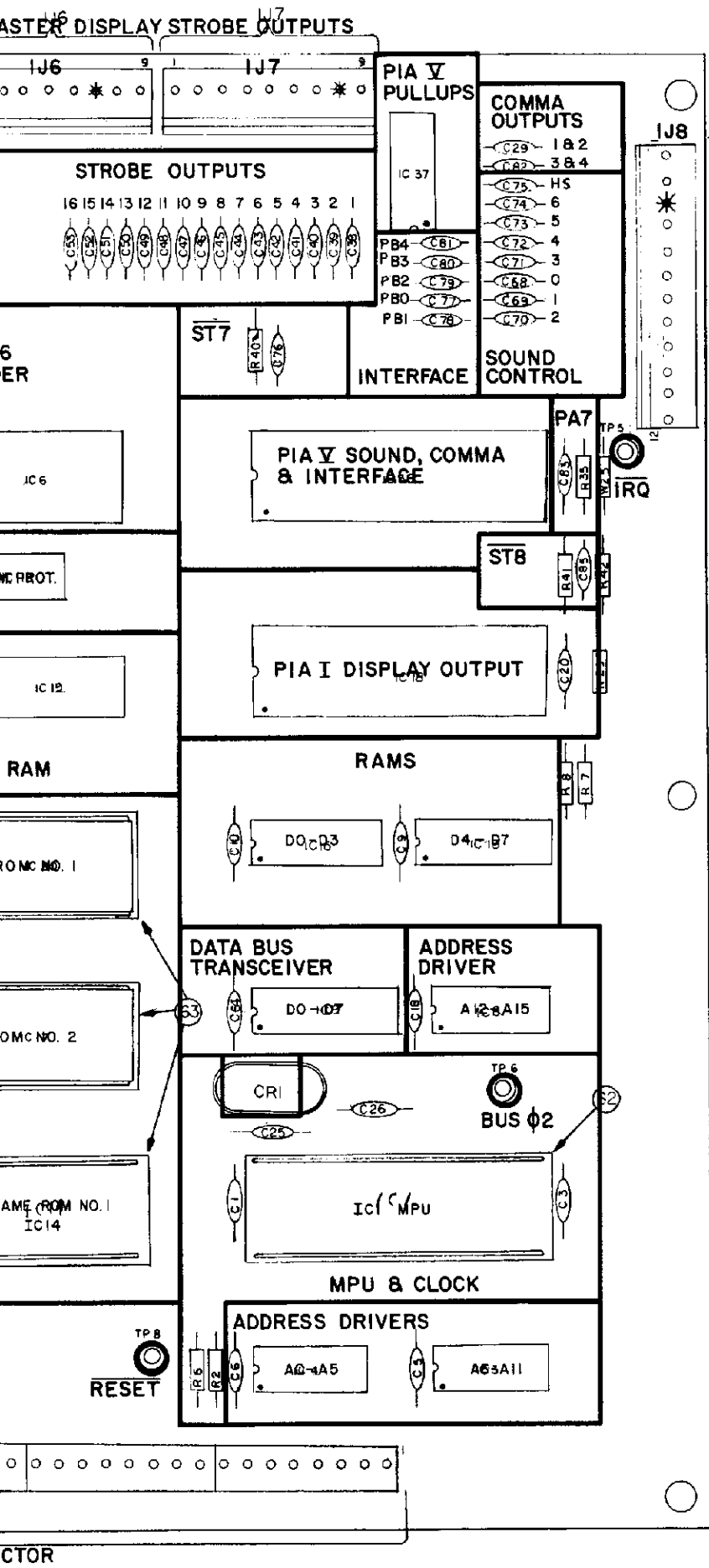

BILL OF MATERIAL

ITEM NO.	PART NO.	PART DESIGNATION	DESCRIPTION	REQD NO.
1	5645-09465-X0		BARE PC. BOARD CPU	1
2	5370-08989-00	IC3,IC4,IC8	8197 HEX TRISTATE BUFFER	3
3	5281-09308-X0	IC9	74LS245 OCTAL BUFFER	1
4	5280-02010-00	IC6	74154 4 TO 16 DECODER	1
5	5280-09013-00	IC7	7404 HEX INVERTER	1
6	5281-09235-00	IC11	74LS10 TRIPPLE 3 INVERTER	1
7	5280-08973-00	IC12	7498 QUAD AND	1
8	5340-09409-X0	IC13,IC16	2114-45 1K X4 STATIC RAM	2
9	5281-09246-00	IC15	74LS139 DUAL 2 TO 4 LINE DECODER	1
10	5341-09353-00	IC20	ROM 2K X8 LOWER	1
11	5341-09554-00	IC17	ROM 4K X8 UPPER	1
12	5430-08972-00	IC18,IC36	MC6821 PIA	2
13	5340-09017-00	IC19	MC 5101 CMOS RAM	1
14	5431-09449-00	IC23	MC 1455 PI TIMER	1
15	5280-09073-00	IC24,IC32,IC33	7400 QUAD 2 INPUT NAND	3
16	5310-09236-00	IC25	4020 CMOS 14 BIT COUNTER	1
17	5310-09237-00	IC10	4071 CMOS QUAD 2 INPUT NOR	1
18	5281-09247-00	IC5,IC31	74LS02 QUAD 2 INPUT NOR	2
19	5280-09407-X0	IC34	7447 BCD TO 7 SEG LED DISP	1
20	5671-09411-00	IC35	MAN 72A 7 SEG LED DISP	1
21	5019-09238-00	IC28,IC29	15 DIP RES./PACK 4.7K OHM	2
22	5019-09223-00	IC37	15 DIP RES./PACK 10K OHM	1
23	5645-09025-00	OS1,DS2	8 STD DIP SWITCHES	2
24	5075-09018-00	ZR1	1N5996 ZENER DIODE 6.8V	1
25	5075-09039-00	ZR2	1N5990 ZENER DIODE 3.9V	1
26	5070-09019-00	D17,D19	1N4148 DIODE	18
27	5160-08938-00	Q3-Q9	2N4401M PNP TRANSISTOR	7
28	5200-09016-00	Q1,Q2	2N4403 PNP TRANSISTOR	2
29	5070-09266-00	D18	1N5817 DIODE	1
30	5520-09020-00	CR1	CRYSTAL 3.58 MHZ	1
31	5010-09338-00	R5,R9,R20	RESISTOR FC 1K OHM 5% 1/4W	3
32	5010-08983-00	R2,R6-R8,R21,R28	RESISTOR FC 3.3K OHM 5% 1/4W	6
33	5010-08991-00	R13-R18,R29,R33-R35,R40,R42	RESISTOR FC 4.7K OHM 5% 1/4W	13
34	5010-09086-00	R22	RESISTOR FC 6.8K OHM 5% 1/4W	1
35	5010-09036-00	R19,R30	RESISTOR FC 100 OHM 5% 1/4W	2
36	5010-09187-00	R36-R39,R46-R50	RESISTOR FC 150 OHM 5% 1/4W	9
37	5010-09113-00	R23,R26	RESISTOR FC 33K OHM 5% 1/4W	2
38	5010-09024-00	R1,R3	RESISTOR FC 10K OHM 5% 1/4W	2
39	5010-09241-00	R25,R32,R40,R11	RESISTOR FC 22K OHM 5% 1/4W	4
40	5010-08998-00	R27	RESISTOR FC 2.2K OHM 5% 1/4W	1
41	5010-09039-00	R12	RESISTOR FC 10 OHM 5% 1/4W	1
42	5010-09442-00	R43	RESISTOR FC 330K OHM 5% 1/4W	1
43	5010-08997-00	R24,R31	RESISTOR FC 27K OHM 5% 1/4W	2
44	5010-09083-00	R44,R45	RESISTOR FC 470 OHM 5% 1/4W	2
45	5043-08980-00	C1-C22,C28,C30,C32-C37,C63-C67,C83	CAPACITOR CERAMIC 101MED 50V	36
46	5040-08986-00	C23	CAPACITOR ELECT 100MFD 10V	1
47	5043-08996-00	C24	CAPACITOR CERAMIC 1MFD 50V	1
48	5043-09169-00	C25,C26	CAPACITOR CERAMIC 27PFD 1KV	2
49	5041-09243-00	C27	CAPACITOR TANT 10 MFD 10V	1
50	5041-09031-00	C31	CAPACITOR TANT 1MFD 25V	1
51	5043-09030-00	C84	CAPACITOR CERAMIC 0.47MFD 50V	1
52	5043-09065-00	C29,C38-C62,C64-C82,C85,C86	CAPACITOR CERAMIC 470PFD 50V	43
53				
54				
55	SEE NOTE		SWITCH MOMENTARY	2
56	5885-09021-00		BATTERY HOLDER #121	1
57	5791-09026-00	IJ1	HEADER 09-64-1083 8 PIN	5
58	5791-09028-00	U3,U4	HEADER 09-65-1041 4 PIN	2
59				
60	5791-09027-00	IJ2,IJ5-IJ7	HEADER 09-65-1021 9 PIN	4
61	5791-09043-00	IJ8	HEADER 09-65-1121 12 PIN	1
62	5700-08985-00		40 PIN IC SOCKET	1
63	5700-09004-00		24 PIN IC SOCKET	6
64	5010-09534-00	W3,W6,W8,W10,W11,W14,W17,W20,W25,W26,W28,W22	RESISTOR FC 0 OHM 1/4W	13
65	5824-09248-00	TP1-TP10	TEST TERMINALS #1502-I	10

NOTE: USE EITHER 5641-09312-00, 5641-09024-00 OR 5641-09371-00

TOLERANCES		WILLIAMS ELECTRONICS, INC.	
UNLESS OTHERWISE SPECIFIED	31/64"	SUBSIDIARY OF THE AMMCO CORP.	
FRACTIONAL	31/64"	3401 N. CALIFORNIA - CHICAGO, ILL. 60618	
DECIMAL	±.0008"	267-8240	
HOLE DIA.	±.0004"	NAME	
ANGULAR	±.01°	PIN BALL CPU SUB-ASSEMBLY	
CONCENTRICITY	T.Y. .008"	MATERIAL	
SCREW THREADS	CLASS 2	HEAT TREATMENT	
		FINISH	
DWG. S.HOBBS	DATE 9-20-80	APPR.	SCALE
			D-8342

- U1-1 +5V
- U1-2 +5V
- U1-3 NC
- U1-4 NC
- U1-5 NC

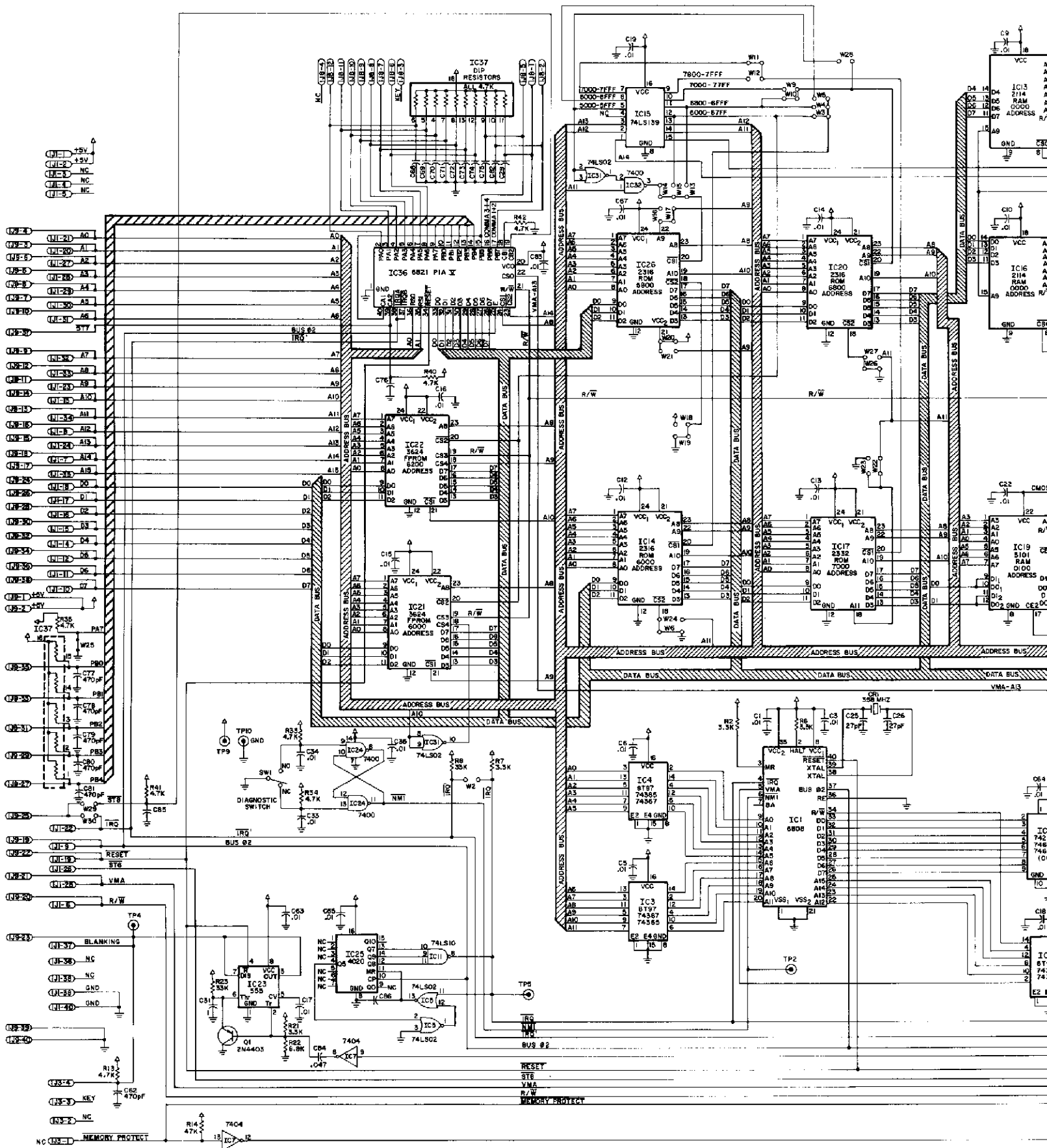

NC U3-1 MEMORY PROTECT

NOTES:

1. ALL RESISTORS, 1/4 WATT UNLESS NOTED OTHERWISE.
2. ALL CAPACITORS, MFD. UNLESS NOTED OTHERWISE.

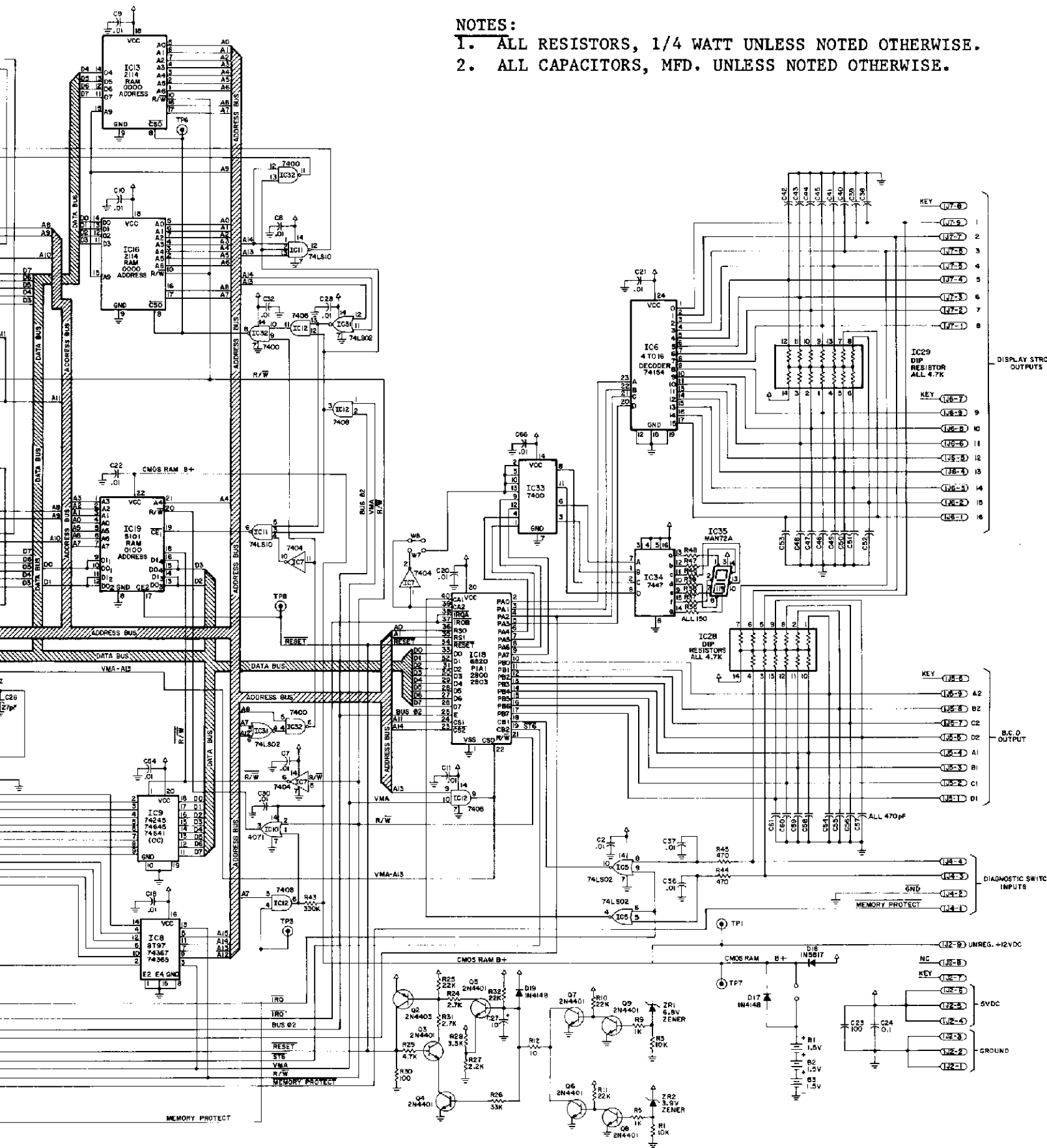

REVISION LETTER	REVISION
C	REVISED AND REDRAWN R.GAY 11-28-77
D	ITEM NO. 28, PT. NO. WAS 5A-8959 & ADDED MOUNTING NOTE FOR R149 THRU R156. R.GAY 4-11-78
E	DELETED ITEM NO. 36, PT. NO. 5A-6985 E.C.D. R.GAY 9-12-78
F	ADDED ITEM NO. 36 A ITEM NO. 22, DELETED (B) RESISTORS & QTY WAS 32 E.C.D. 4-24 R.GAY 10-4-78

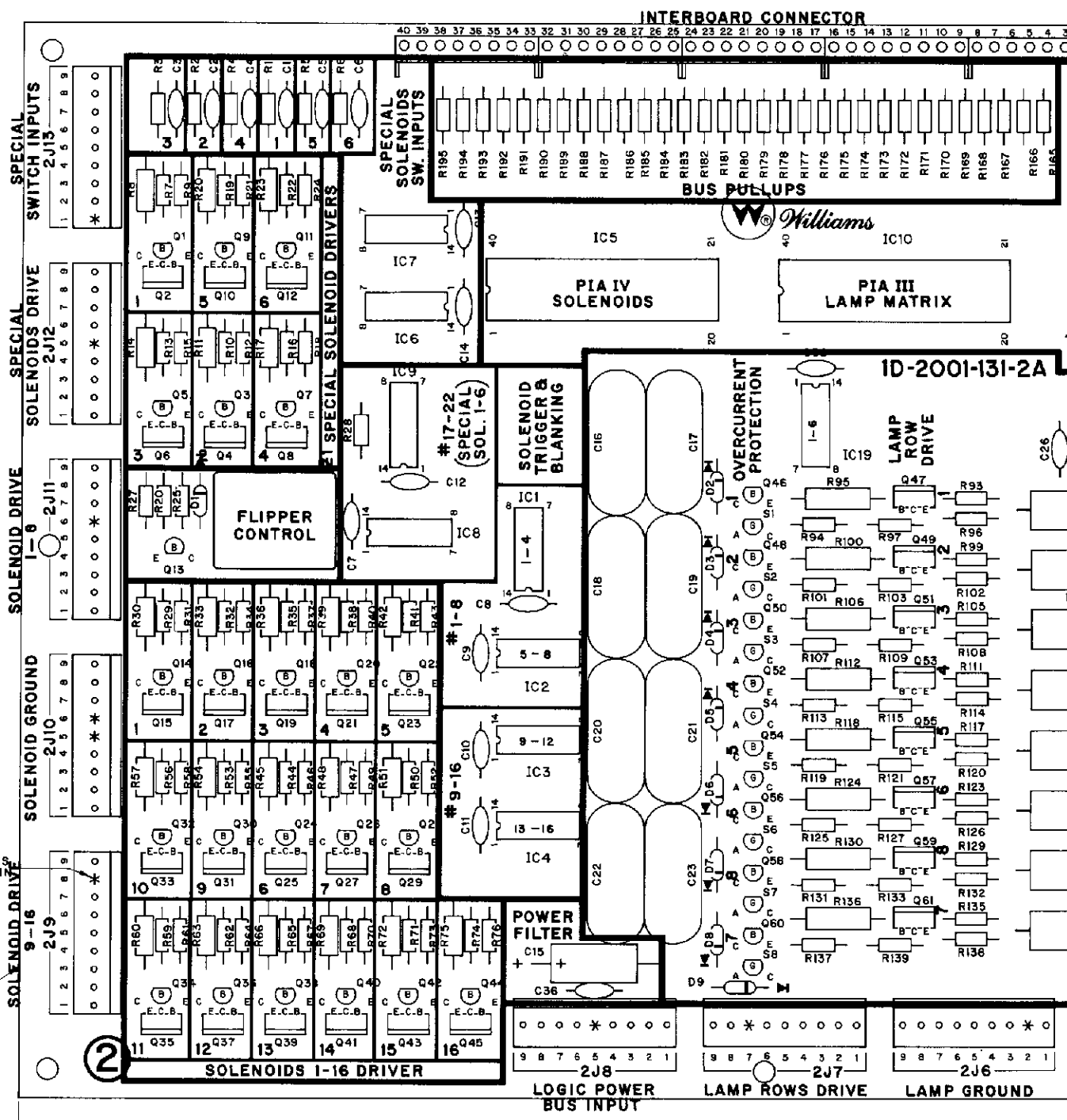

CONNECTOR

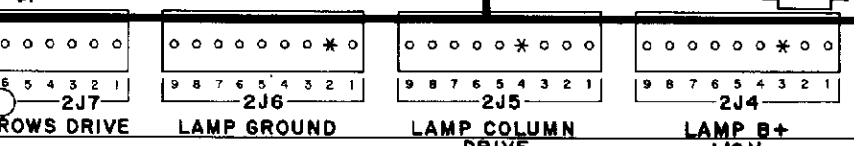
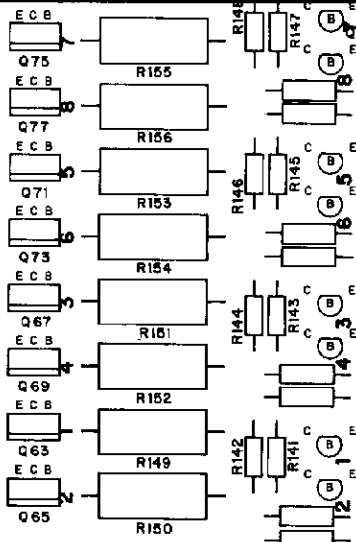
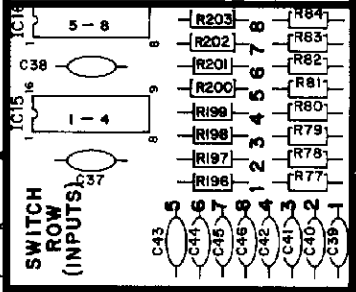
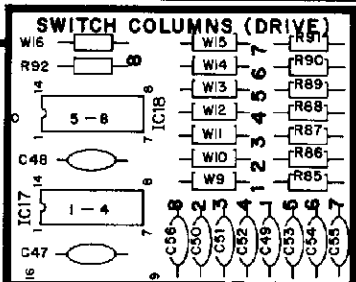
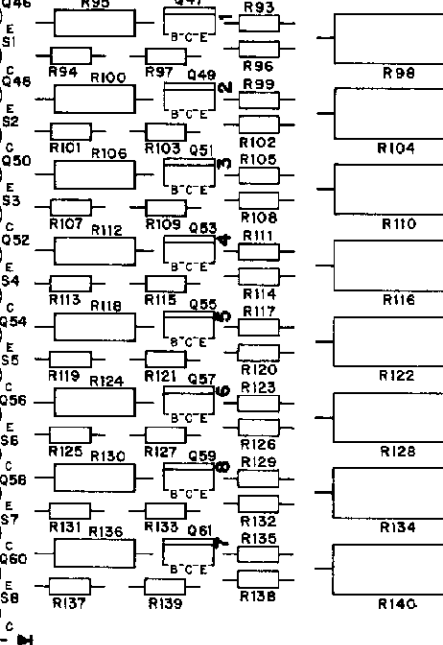
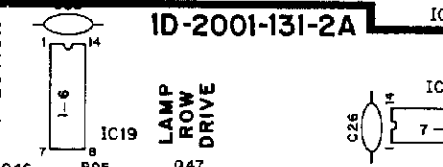
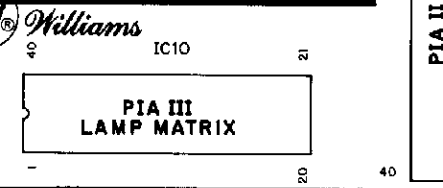
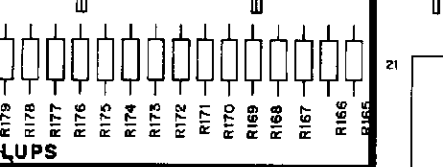
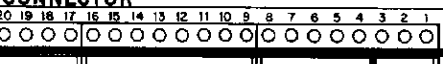

ACTLY 13.000"

BILL OF MATERIAL

ITEM NO.	PART NO.	PART DESIGNATION	DESCRIPTION	REQ'D. NO.
1	1B-2001-131		BARE P.C. BOARD	1
2	5A-8948	IC8, IC9	N7402 QUADRUPLE 2 INPUT POSITIVE NDR GATE	2
3	5A-8974	IC12, IC17, IC18, IC19	N7406 HEX. INVERTER BUFFER DRIVERS W/ OPEN COLLECTOR HIGH VOLTAGE OUTPUTS	4
4	5A-8973	IC1 THRU IC4, IC6, IC7, IC13, IC14	N7408 QUADRUPLE 2 INPUT POSITIVE AND GATE	8
5	5A-8975	IC15, IC16	MC14049 INVERTING HEX. BUFFER	2
6	5A-8972	IC5, IC10, IC11	MC6880 PERIPHERAL INTERFACE ADAPTER	3
7	5A-8958	Q1, Q3, Q5, Q7, Q9, Q11, Q13, Q14, Q16, Q18, Q20, Q22, Q24, Q26, Q28, Q30, Q32, Q34, Q36, Q38, Q40, Q42, Q44	2N4401 NPN TRANSISTOR	23
8	5A-8976	Q46, Q48, Q50, Q52, Q54, Q56, Q58, Q60, Q62, Q64, Q66, Q68, Q70, Q72, Q74, Q76	2N6427 DARLINGTON NPN TRANSISTOR	16
9	5A-8977	Q2, Q4, Q6, Q8, Q10, Q12, Q14, Q16, Q18, Q20, Q22, Q24, Q26, Q28, Q30, Q32, Q34, Q36, Q38, Q40, Q42, Q44	TIP122 DARLINGTON NPN POWER TRANSISTOR	22
10	5A-8978	Q63, Q65, Q67, Q69, Q71, Q73, Q75, Q77	TIP42 PNP POWER TRANSISTOR	8
11	5A-8979	Q47, Q49, Q51, Q53, Q55, Q57, Q59, Q61	2N6122 NPN POWER TRANSISTOR	8
12	5A-8258	D1	1N4001 DIODE	1
13	5A-8916	D2 THRU D8	1N4148 DIODE	8
14	5A-9014	S1 THRU S8	2N5060 SCR	8
15	5A-8980	C1 THRU C14, C24, THRU C26, C30, C37, C38, C47, C48	CAPACITOR, CERAMIC, 01 MFD. +50 -20% 50 V.	22
16	5A-8995	C16 THRU C23	CAPACITOR, POLYESTER FILM, 1 MFD. 10 V.	7
17	5A-9065	C37 THRU C45, C49 THRU C56	CAPACITOR, CERAMIC, 470 PFD. 20% 50 V.	16
18	5A-8986	C15	CAPACITOR, ELECT., 100 MFD. 10 V.	1
19	5A-8996	C35	CAPACITOR, CERAMIC, 1 MFD. +80 -20% 80 V.	1
20	5A-8991	R1 THRU R6, R27, R77 THRU R92, R107 THRU R193	RESISTOR, FC, 4.7 K OHM 10% 1/4 W	62
21	5A-8983	R27	RESISTOR, FC, 3.3 K OHM 10% 1/4 W	1
22	5A-8984	R95, R97, R102, R103, R108, R109, R114, R115, R121, R22, R26, R27, R32, R33, R36, R39, R96 THRU R203	RESISTOR, FC, 1 K OHM 10% 1/4 W	24
23	5A-8992	R7, R10, R13, R16, R19, R22, R23, R32, R35, R36, R41, R44, R47, R50, R53, R56, R59, R62, R65, R68, R71, R74	RESISTOR, FC, 560 OHM 10% 1/4 W	22
24	5A-8993	R8, R11, R14, R17, R20, R23, R30, R33, R36, R39, R42, R45, R48, R51, R54, R57, R60, R63, R66, R69, R72, R75	RESISTOR, FC, 68 OHM 10% 1/4 W	22
25	5A-8997	R9, R12, R15, R18, R21, R24, R25, R31, R34, R37, R40, R43, R46, R49, R52, R55, R58, R61, R64, R67, R70, R73, R76	RESISTOR, FC, 2.7 K OHM 10% 1/4 W	23
26	5A-8817	R26	RESISTOR, FC, 10 K OHM 10% 1/4 W	1
27	5A-8998	R141 THRU R148	RESISTOR, FC, 2.2 K OHM 10% 1/4 W	8
28	5A-8999-1	R149 THRU R156	RESISTOR, FC, 2T OHM 10% 2 W	8
29	5A-9084	R95, R100, R106, R112, R118, R124, R130, R136	RESISTOR, FC, 100 OHM 10% 3 W	8
30	5A-9085	R93, R99, R105, R111, R117, R123, R129, R135	RESISTOR, FC, 1.5 K OHM 10% 1/4 W	8
31	5A-8086	R94, R101, R107, R113, R119, R125, R131, R137	RESISTOR, FC, 6.8 K OHM 10% 1/4 W	8
32	5A-9037	R98, R104, R110, R116, R122, R28, R34, R40	RESISTOR, WIREWOUND, 4 OHM 10%, 3 WATT	8
33	5A-8994	Z1	RELAY - 4 POLE - 5 AMP CONTACTS 60 OHM COIL, 5 V.D.C.	1
34	5A-9066	2P1	8 PIN RECEPTACLE	5
35	5A-9027	2J2 THRU 2J13	9 PIN HEADER	12
36	5A-8834	W9 THRU W16	RESISTOR, FC, 0 OHM, 1/4 W	8

★ R149 THRU R156 MUST BE MOUNTED 1" ABOVE SURFACE OF BOARD.

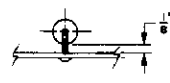

WILLIAMS ELECTRONICS, INC.
 SUBSIDIARY OF XCOR CORPORATION
 3401 N. CALIFORNIA CHICAGO, ILL. 60618 CORNELIA T-2240

PART NAME: DRIVER BOARD ASSEMBLY

DWN: R. Gdy DATE: 8-16-77 APP'D: SCALE: 2x1 PART NO: D-7997

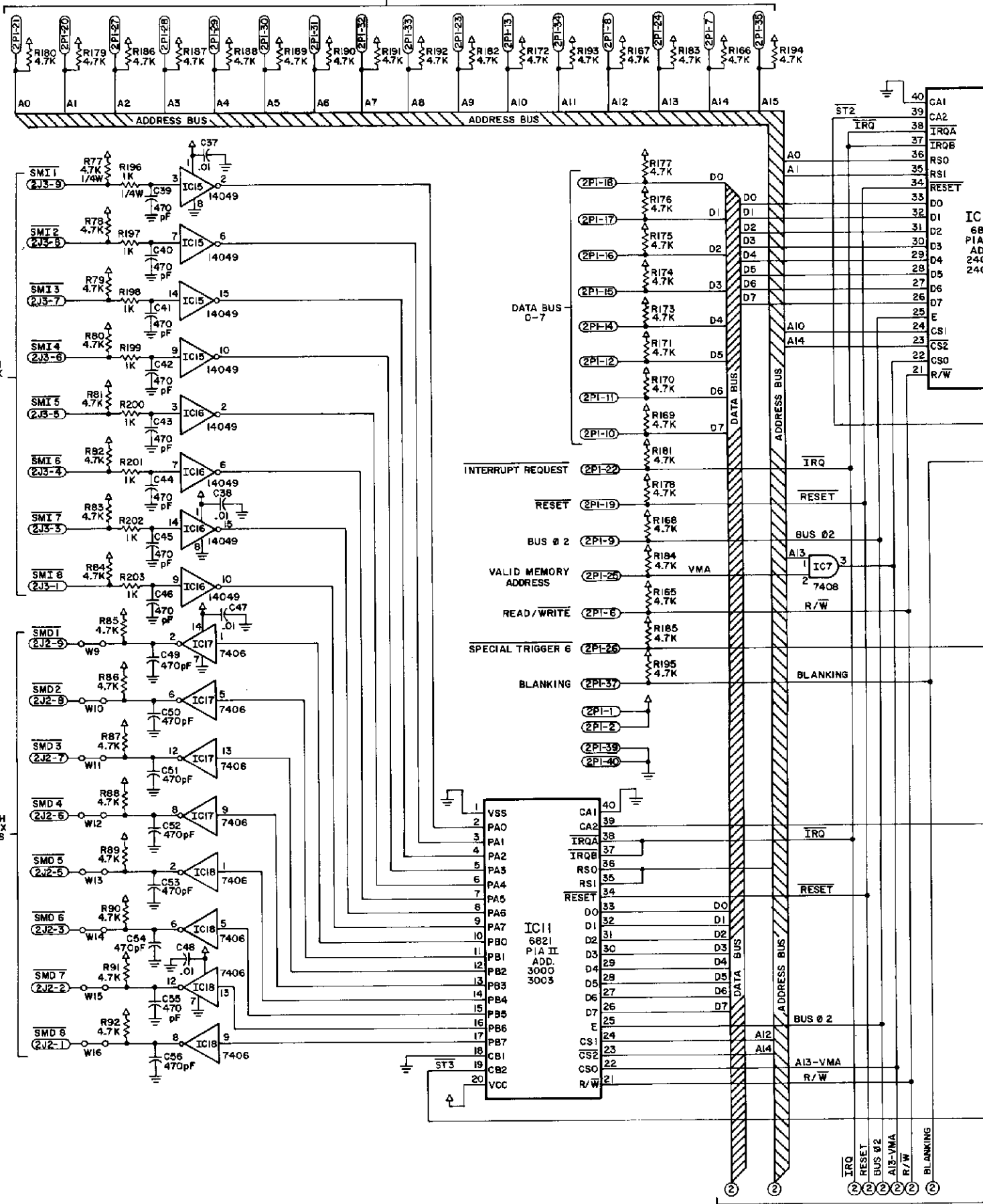

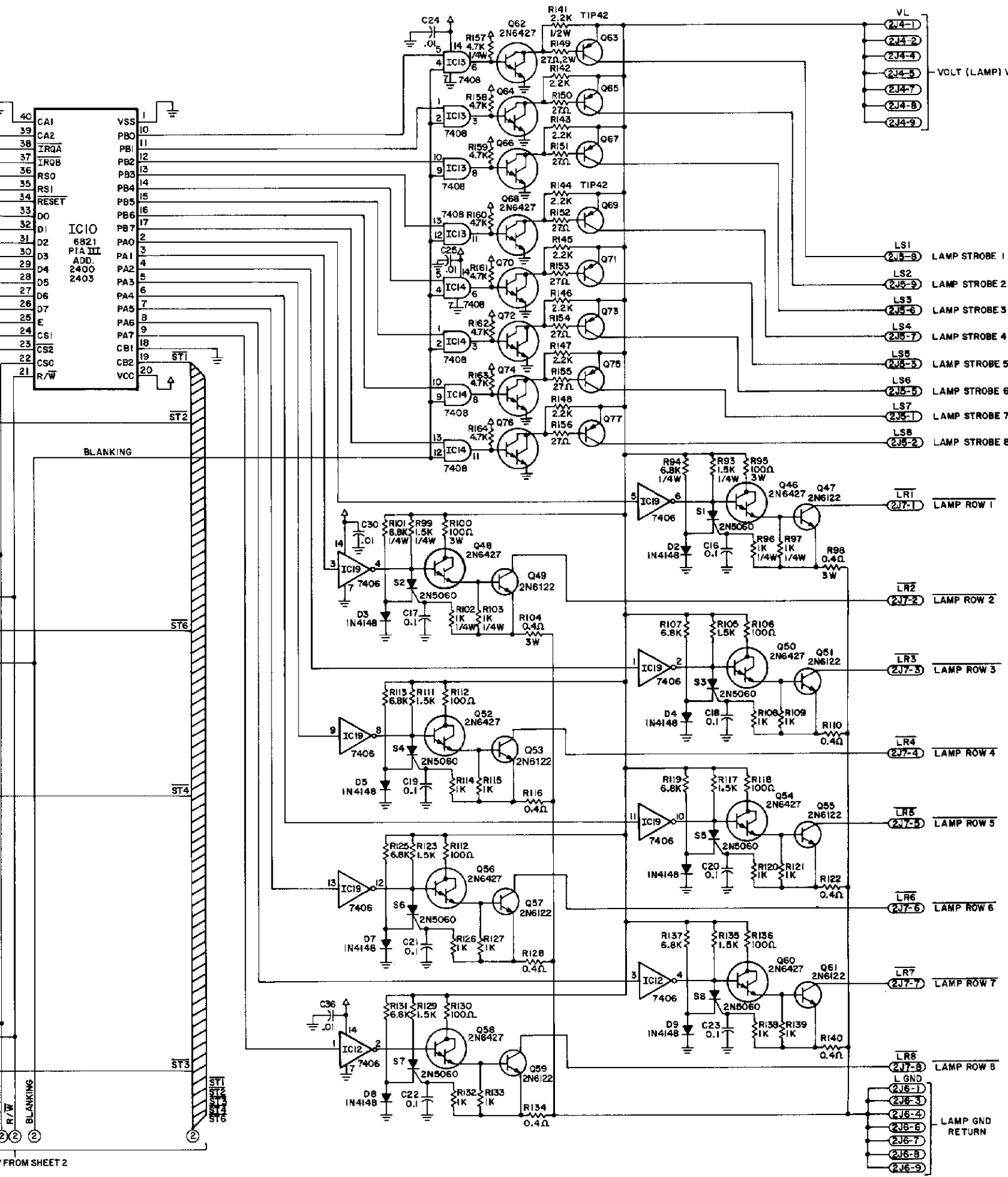

Driver Board Logic Diagram (Sheet 1 of 2)

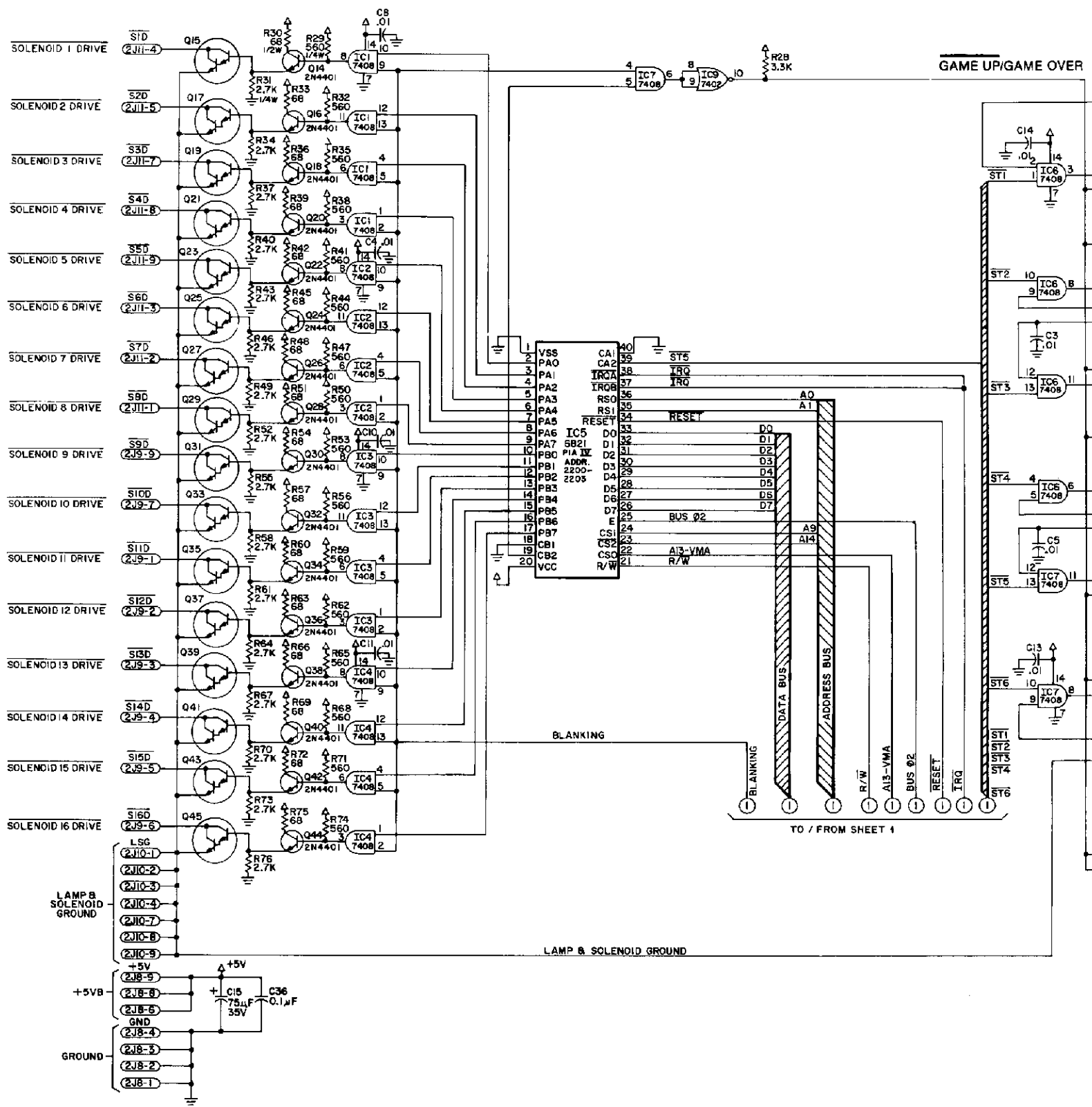

GAME UP/GAME OVER

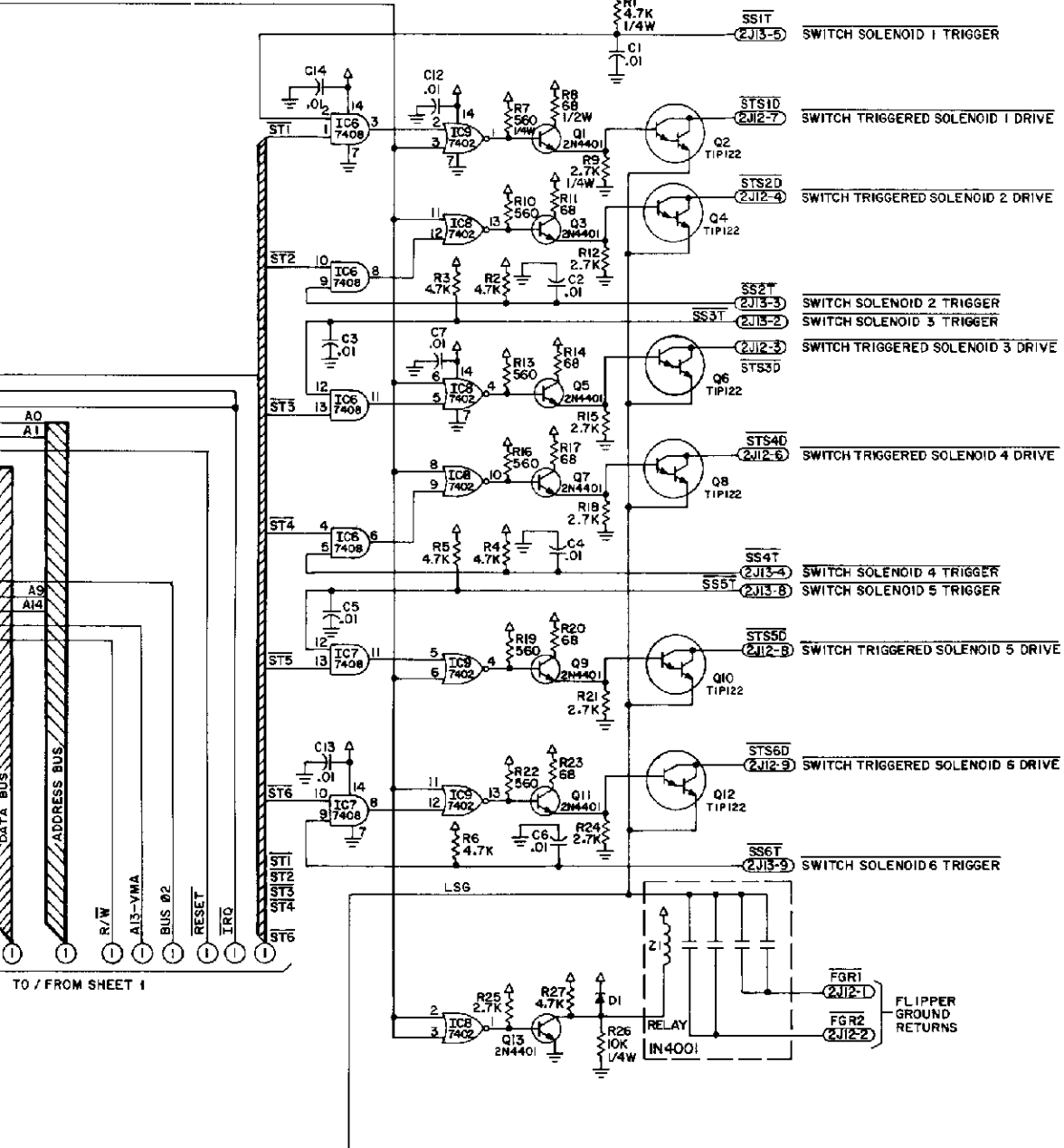

BILL OF MATERIAL

ITEM NO.	PART NO.	PART DESIGNATION	DESCRIPTION	REQ'D NO.
1	5765-09466		BASE P.C. BOARD	1
2	5013-09426	R7	RESISTOR, 2.15K, 1%, 1/4 W, METAL FILM	1
3	5013-09427	R8	RESISTOR, 4.99K, 1%, 1/4 W, METAL FILM	1
4	5010-09428	R11	RESISTOR, 1.5K, 2%, 1/4 W, CARBON FILM	1
5	5010-09085	R10	RESISTOR, 2.7K, 2%, 1/4 W	1
6	5010-09341	R9	RESISTOR, 2.7K, 2%, 1/4 W	1
7	5010-09508	R12	RESISTOR, 270 OHM, 2%, 1/4 W, CARBON FILM	1
8	5012-09429	R13	POWER RESISTOR, 0.12 OHM, 5%, 1 W	1
9	5013-09536	R1, R4	RESISTOR, 39K, 5%, 1 W	2
10	5010-09061	R2, R5	RESISTOR, 680 OHM, 2 W	2
11	5010-09069	R3, R6	RESISTOR, 330K, 5%, 1/2 W	2
12	5040-09419	C10	CAP., ELECTROLYTIC, 18,000 MFD, 20V, AXIAL	1
13	5040-09420	C9	CAP., ELECTROLYTIC, 1,000 MFD, 25V, RADIAL OR AXIAL	1
14	5040-09423	C12	CAP., ELECTROLYTIC, 330 MFD, 10V, RADIAL	1
15	5043-09065	C15	CAPACITOR, 470 pF	1
16	5040-09053	C1, C3	CAPACITOR, 100 MFD, ELECT., 150V	2
17	5040-09070	C5	CAPACITOR, 100 MFD, ELECT., 100V, AXIAL OR RADIAL	1
18	5070-09446	C14	CAPACITOR, 0.1 MFD, 50V, DISC.	1
19	5070-06258	D1, D2, D3, D4, D5, D6	DIODE, 1N4001	6
20	5075-09059	ZR1, ZR3	ZENER, 1N5990, 3.9V, 5%	2
21	5075-09060	ZR2, ZR4	ZENER, 1N764, 100V, 5%	2
22	5060-09424	IC1	VOLTAGE REGULATOR, MC1723 PC	1
23	5043-09443	C2, C4, C6	CAPACITOR, 0.1 MFD, 200V, DISC	3
24	5040-09421	C7	CAPACITOR, 100 MFD, 25V, RADIAL	1
25	5164-09037	Q1	TRANSISTOR, SDS 201 NPN	1
26	5164-09036	Q4	TRANSISTOR, MPS 002 NPN	1
27	5194-09058	Q3	TRANSISTOR, SDS 202 PNP	1
28	5194-09055	Q2	TRANSISTOR, MPS 052 PNP	1
29	5705-04431		HEAT SINK	1
30	5791-09067	3J5	CONNECTOR, 6 PIN (H)	1
31	5791-09074	3J6	CONNECTOR, 15 PIN (H)	1
32	5791-09027	3J8, 3J3	CONNECTOR, 9 PIN (H)	2
33	5791-09038	3J2	CONNECTOR, 6 PIN (H)	1
34	5162-09425	Q5	TRANSISTOR, POWER, 2N6087 NPN	1
35	5791-09043	3J4	CONNECTOR, 12 PIN (H)	1
36	5791-09435	3J7	CONNECTOR, 3 PIN (H)	1
37	5791-09436	3J9	CONNECTOR, 2 PIN (H)	1
38	5791-09066	3J1	CONNECTOR, 12 PIN	1
39	5732-09178		FUSE HOLDER	1
40	5731-09128	F2	FUSE, 2-1/2 AMP, S.B.	1
41	5730-09071	F3	FUSE, 8 AMP	1
42	5730-06508	F4	FUSE, 10 AMP, OR, 1	1
43	5730-09127	F7	FUSE, 20 AMP	1
44	5731-08761	F1	FUSE, 20 AMP	1
45	5017-09061	VR1	VARIABLE RESISTOR	1
47A	5700-09445		SOCKET	1
47B	5701-09538		NICA INSULATOR	1
47	5580-09555	K1	RELAY, 24 VDC, 10 AMP, DPDT	1
48	5824-09248		TERMINAL, #1502-1 (TEST POST)	3
49	5100-09418	BR-1	BRIDGE RECTIFIER, 35 AMP, 100V	1
50	5705-09042		HEAT SINK	2
51	3A-7520-1		TIE WRAP	1
52	4005-01016-07		5-40 x 7/16 R.H. MECH. SCREW	2
53	4435-01117		5-40 HEX NUT	2
54		W1, W2	JUMPER, #18 AWG	2
55	5040-09422	C8	CAPACITOR, 47 MFD, 50V, RADIAL	1
56	20-9229		THERMAL COMPOUND	1
57			LEAD WIRE, #18 AWG (3")	3
58	5731-09432	F6, F5	FUSE, 7A, S.B., 250V	2

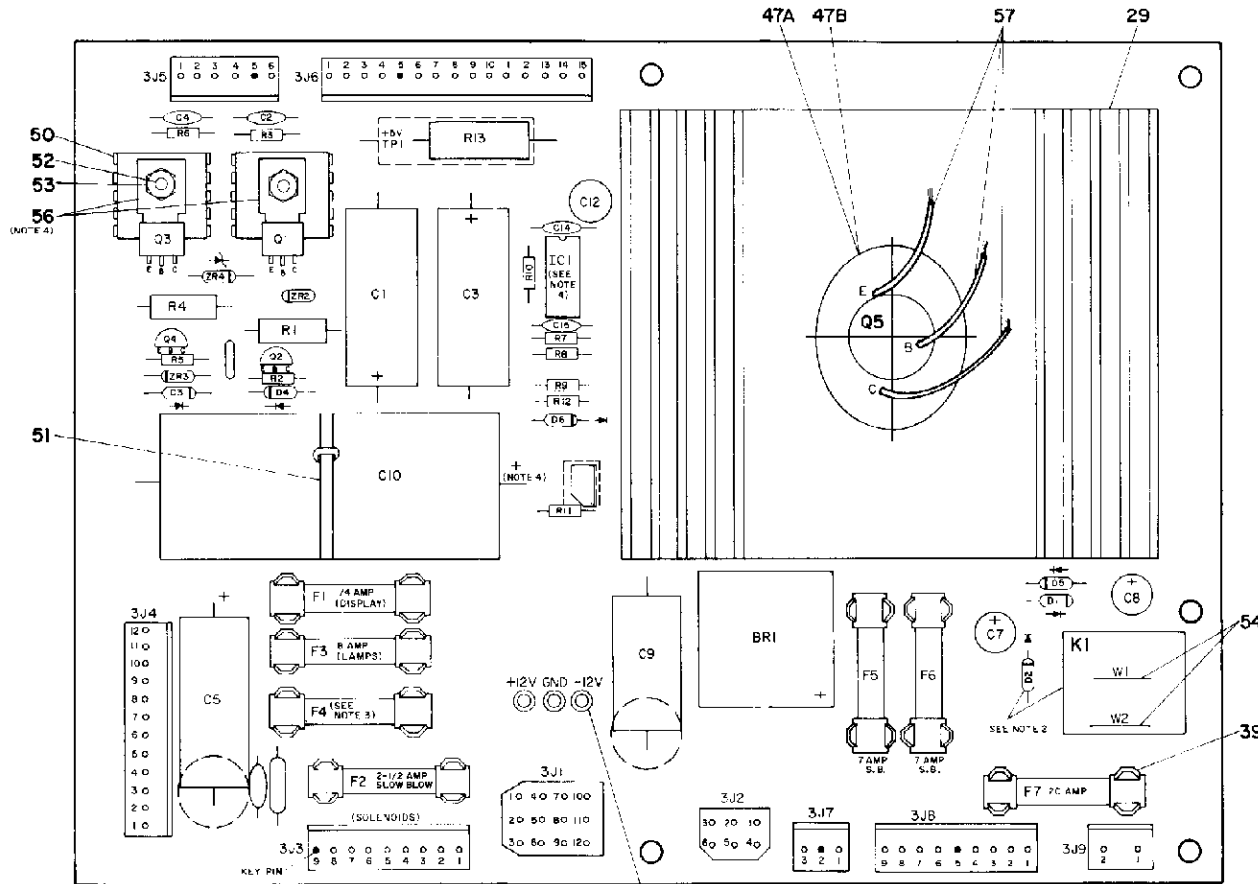

NOTES: 1. HEAT SINK COMPOUND MUST BE APPLIED BETWEEN TRANSISTOR AND HEAT SINK.
 2. FOR BLACKOUT AND FUTURE GAME WITH SAME FEATURE REMOVE JUMPERS (W1 & W2) AND INSERT RELAY K1 (DUAL USE AND 3J7).
 3. ON FLIPPER GAMES F4 IS 10 AMPS OR (DUAL ACTION FLIPPERS) 15 AMPS ON SHUFFLE ALLEYS F4 IS 50 AMPS.
 4. OBSERVE INDEX MARK OF INTEGRATED CIRCUIT, POLARITY OF CAPACITORS, DIODE AND POSITION OF TRANSISTORS.
 5. REFERENCE DRAWING SCHEMATIC 16-8786.

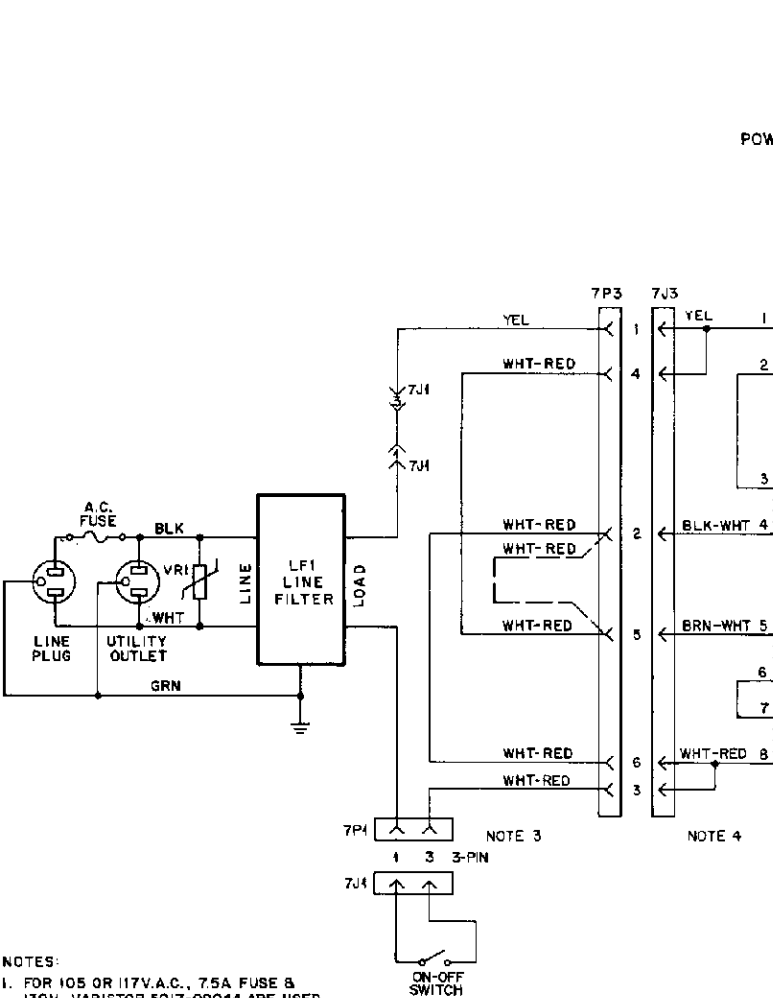

POWER WIRING

- NOTES:
1. FOR 105 OR 117V.A.C., 7.5A FUSE & 130V. VARISTOR 5017-09044 ARE USED.
 2. FOR 210 OR 235V.A.C., 4A FUSE & 275V. VARISTOR 5017-09083 ARE USED.
 3. JUMPER WIRES ON 6P1 SHOWN WITH SOLID LINES ARE CONNECTED FOR 117V.A.C. OPERATION. ONLY THE ONE SHOWN WITH A DASHED LINE IS CONNECTED FOR 220V.A.C. OPERATION.
 4. FOR LOW-LINE CONDITIONS (105 OR 210V.A.C.) MOVE BLK-WHT WIRE FROM 6T1-4 TO 6T1-3) & MOVE 2 WHT-RED WIRES FROM 6T1-8 TO 6T1-7.

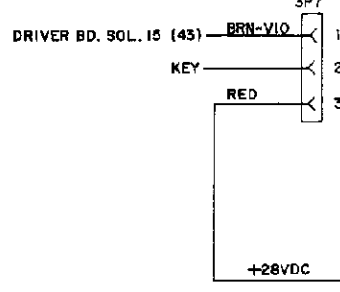

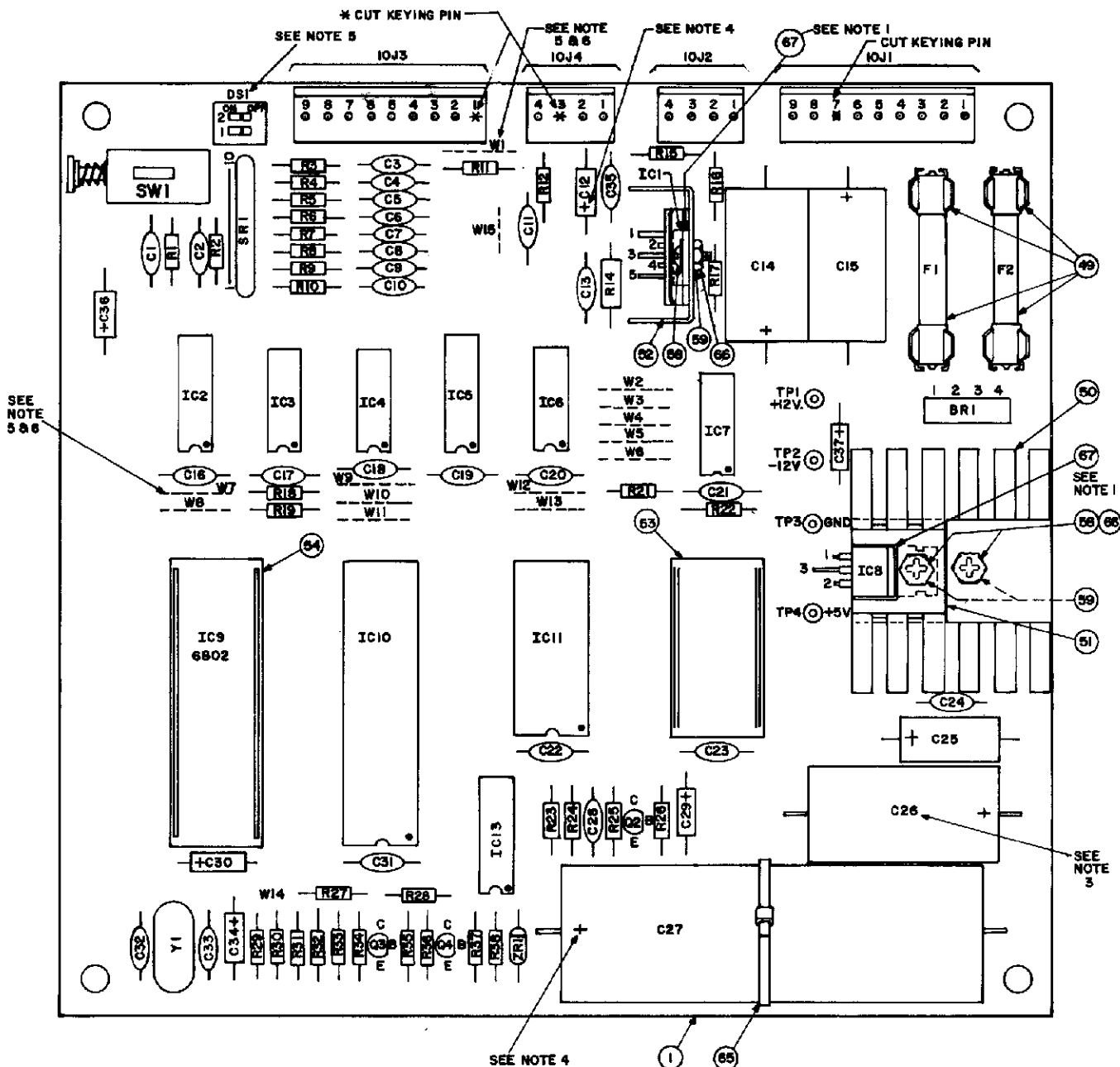

SOUND BOARD JUMPERS

JUMPERS USED	TOM TYPE	FORMAT	GAMES USED IN
W2, W5, W7, W9, W10, W15	2K x 8 2516, 2716	Sound & Speech	Gorgar, Blackout, Firepower, Black Knight, Jungle Lord, Pharaoh.
W1, W2, W5, W7, W9, W10, W15	2K x 8 2516, 2716	Sound Only	Defender Video & Pin, Solar Fire, Barracora, Hyperball, Stargate, Cosmic Gunfight, Varkon, Time Fantasy.
W3, W4, W5, W7, W10, W15	4K x 8 2532	Sound & Speech	Sinistar (Upright & Cockpit Front)
W1, W3, W4, W5, W7, W10, W15	4K x 8 2532	Sound Only	Robotron, Joust Video & Pin, Bubbles, Sinistar (Cockpit Rear)
W1, W2, W4, W5, W7, W10, W15	2K x 8 2516, 2716	Sound Only	Warlock
W1, W3, W6, W7, W9, W11, W12, W15	512 x 8 7841	Sound Only	Big Strike

BILL OF MATERIAL

ITEM NO.	PART NO.	PART DESIGNATION	DESCRIPTION	REQ'D. NO.
1	01-2 01-146-6		BARE P.C. BOARD REV F	1
2	5370-09156-00	IC1	TDA 2002 V AUDIO AMPLIFIER	1
3	5280-09012-00	IC2	7442 BCD-DEC DECODER	1
4	5280-09073-00	IC3	7400 QUAD 2 INPUT NAND	1
5	5280-08973	IC4	7408 QUAD 2 INP. AND GATE	1
6	5310-09153-00	IC5	4050 BUFFER	1
7	5310-09154-00	IC6	4068 8 INPUT NAND GATE	1
8	5310-08971-00	IC7	4069 HEX INVERTER	1
9	5250-09157-00	IC8	7805 5 VOLT REG. W/TO 220 CASE	1
10	5430-08972-00	IC10	6821 P.I.A.	1
11	5340-09003-00	IC11	6810 RAM	1
12	5371-09152-00	IC13	1408 D/A CONVERTER	1
13	5160-08938-00	Q2, Q3, Q4	2N4401 NPN TRANSISTOR	3
14				
15	5075-09018-00	ZR1	1N5996A 6.8V ZENER DIODE	1
16				
17	5100-09357-00	BR1	MDA 200/3N253	1
	5100-09158-00		BRIDGE RECTIFIER	0
18	5520-09020-00	Y1	3.58 MHz CRYSTAL	1
19	5010-08991-00	R1,R18,R19,R21,R22, R27,R30,R31, R32	RESISTOR, FC, 4.7K OHM, 5% 1/4 WATT	9
20	5010-09036-00	R2 thru R10	RESISTOR, FC, 100 OHM, 5% 1/4W	9
21	5010-09358-00	R12,R15,R28,R36,R38	RESISTOR, FC, 1K OHM, 5% 1/4W	5
22	5010-09181-00	R14	RESISTOR, FC, 1 OHM, 10% 1/2 WATT	1
23	5010-09161-00	R16	RESISTOR, FC, 2.2 OHM, 5% 1/4 WATT	1
24	5010-09361-00	R17	RESISTOR, FC, 220 OHM, 5% 1/2 WATT	1
25				
26	5010-08983-00	R23, R24, R26	RESISTOR, FC, 3.3K OHM, 5% 1/4 WATT	3
27	5010-09179-00	R25	RESISTOR, FC, 3.3M OHM, 5% 1/4 WATT	1
28	5010-09035-00	R29	RESISTOR, FC, 47K OHM, 5% 1/4 WATT	1
29	5010-09034-00	R33, R35, R37	RESISTOR, FC, 10K OHM, 5% 1/4 WATT	3
30	5010-09039-00	R34	RESISTOR, FC, 10 OHM, 5% 1/4 WATT	1
31	5043-08980-00	C1, C16 thru C23, C31	CAPACITOR, CER. .01 MFD. 50V. +80%, -20%	10
32	5043-09065-00	C2 thru C10	CAPACITOR, CER. 470 PFD. 50V. +-20%	9
33	5043-09345-00	C11	CAPACITOR, CER. .001 MFD. +-20% 100V.	1
34	5040-09365-00	C12, C30, C36	CAPACITOR, ELECT. 1 MFD. 63V. -10 +50%	3
35	5043-08996-00	C13, C24, C35	CAPACITOR, CER. .1 MFD. 50V. +-20%	3
36	5040-09165-00	C14	CAPACITOR, ELECT. 1,000 MFD. 16V. +-20%	1
37	5040-09164-00	C15	CAPACITOR, ELECT. 47C MFD. 10V. +-20%	1
38	5040-08986-00	C25	CAPACITOR, ELECT. 100 MFD. 10V. +-20%	1
39	5040-08893-00	C26	CAPACITOR, ELECT. 1,000 MFD. 25V. +-20%	1
40	5040-09376-00	C27	CAPACITOR, ELECT. 4700 MFD. 16V. +-20%	1
41	5043-09180-00	C28	CAPACITOR, CER. 47 PFD. 1K V. +-20%	1
42	5040-09343-00	C29	CAPACITOR, ELECT. 10 MFD. 20V	1
43	5043-09169-00	C32, C33	CAPACITOR, CER. DISC. 27 PFD. 1KV. +-10%	2
44	5041-09163-00	C34	CAPACITOR, TANTALUM 2.2 MFD. 15V. +-20%	1
45	5041-09031-00	C37	CAPACITOR, TANTALUM 1 MFD. 25V. +-20%	1
46	5641-09658-00	SW1	MOMENTARY SWITCH SPDT	1
47	5645-09330-00	DS1	2 STD. DIP SWITCH	1
48	5731-06314-00	F1, F2	4 AMP SLOW BLOW FUSE	2
49	5732-09178-00		FUSEHOLDER	4
50	5705-09172-00		HEAT SINK THERMALLOY #6072B	1
51	5705-09173-00		HEAT SINK THERMALLOY #6071B	1
52	5705-09199-00		HEAT SINK THERMALLOY #6030	1
53	5700-09004-00		24 PIN SOCKET	1
54	5700-08985-00		40 PIN SOCKET	1
55	5791-09027-00	10J1, 10J3	9 PIN MALE CONNECTOR 09-65-1091	2
56	5791-09028-00	10J2, 10J4	4 PIN MALE CONNECTOR 09-65-1041	2
57				
58	4006-01003-06		6-32x3/8" P-PH-S	3
59	4406-01117-00		6-32 HEX NUT	3
60	5010-09534-00		0 OHM RESISTOR	A/R
61	5824-09248-00	TP1 THR TP4	TERMINAL #1502-1	4
62	5010-09363-00	R11	RESISTOR, FC, 5.6K OHM 5% 1/4 WATT	1
63				
64	5019-09362-00	SRI	RESISTOR, 4.7K OHM 10 PIN SIP	1
65	03-7520-1		TIE WRAP	1
66	4703-00007-00		#6 EXT. LOCKWASHER	3
67	20-9229		THERMAL COMPOUND	.01

NOTES:

1. USE THERMAL COMPOUND BETWEEN IC1 AND IC8, AND HEAT SINKS.

2. CAUTION: AVOID STATIC DISCHARGE DAMAGE TO MOS LOGIC.

3. SYMBOLS SHOWN ON COMPONENTS ARE FOR REFERENCE ONLY. DO NOT SCREEN OR STAMP.

4. OBSERVE INDEX MARK OF ALL INTEGRATED CIRCUITS;

DIODES D1, D2, AND ZR1;

CAPACITORS C12, C14, C15, C25, C26, C27;

CONNECTORS 10J1, 10J2, 10J4, 10J3, 10J5;

POSITION OF TRANSISTORS Q1, Q2, Q3, Q4.

5. JUMPERS

W2) W3)
W5) W4)
W9) IN W6)
W10) W11) OUT
W12)
W13)

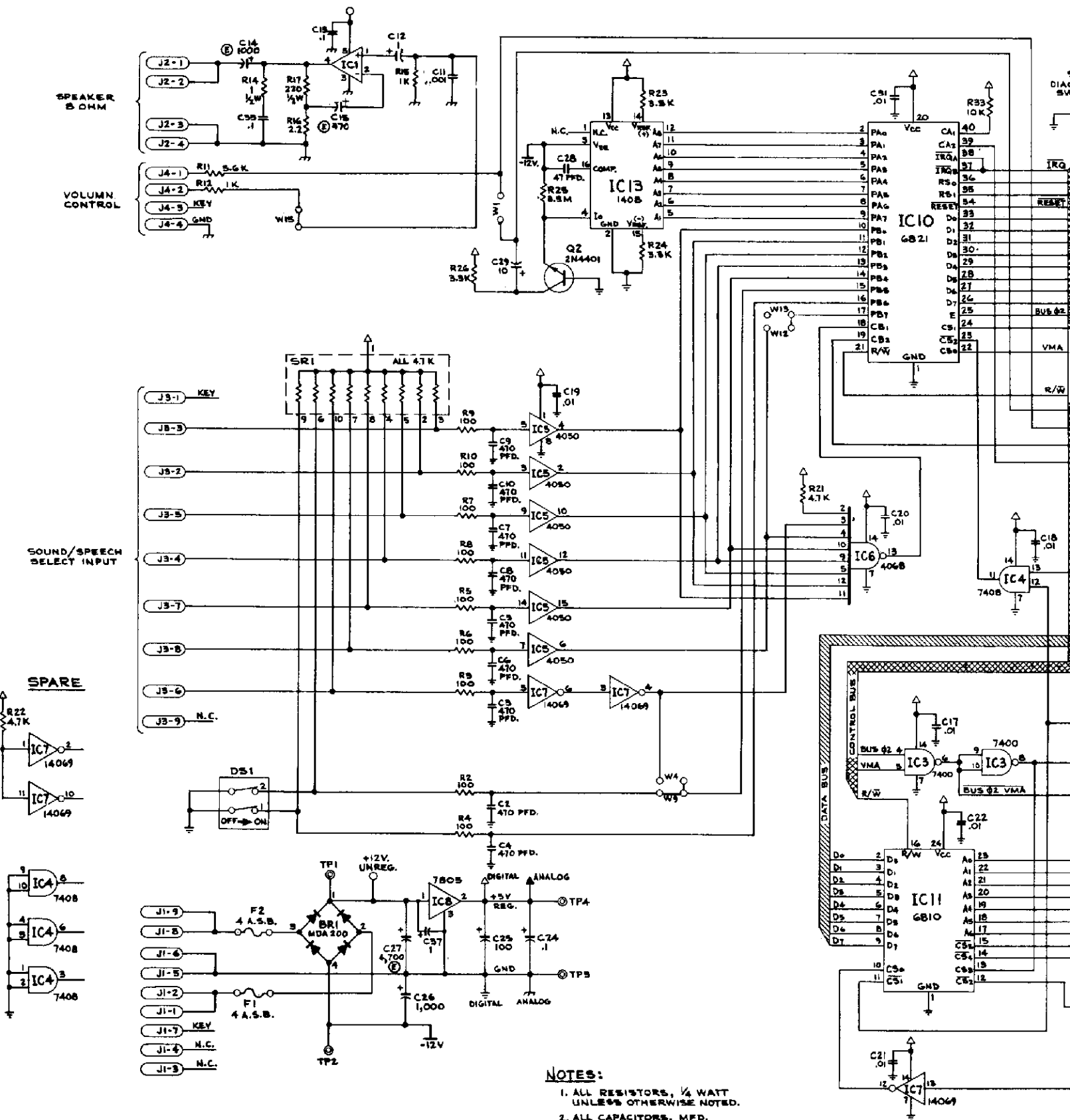

- NOTES:**
1. ALL RESISTORS, 1/4 WATT UNLESS OTHERWISE NOTED.
 2. ALL CAPACITORS, MFD. UNLESS OTHERWISE NOTED.

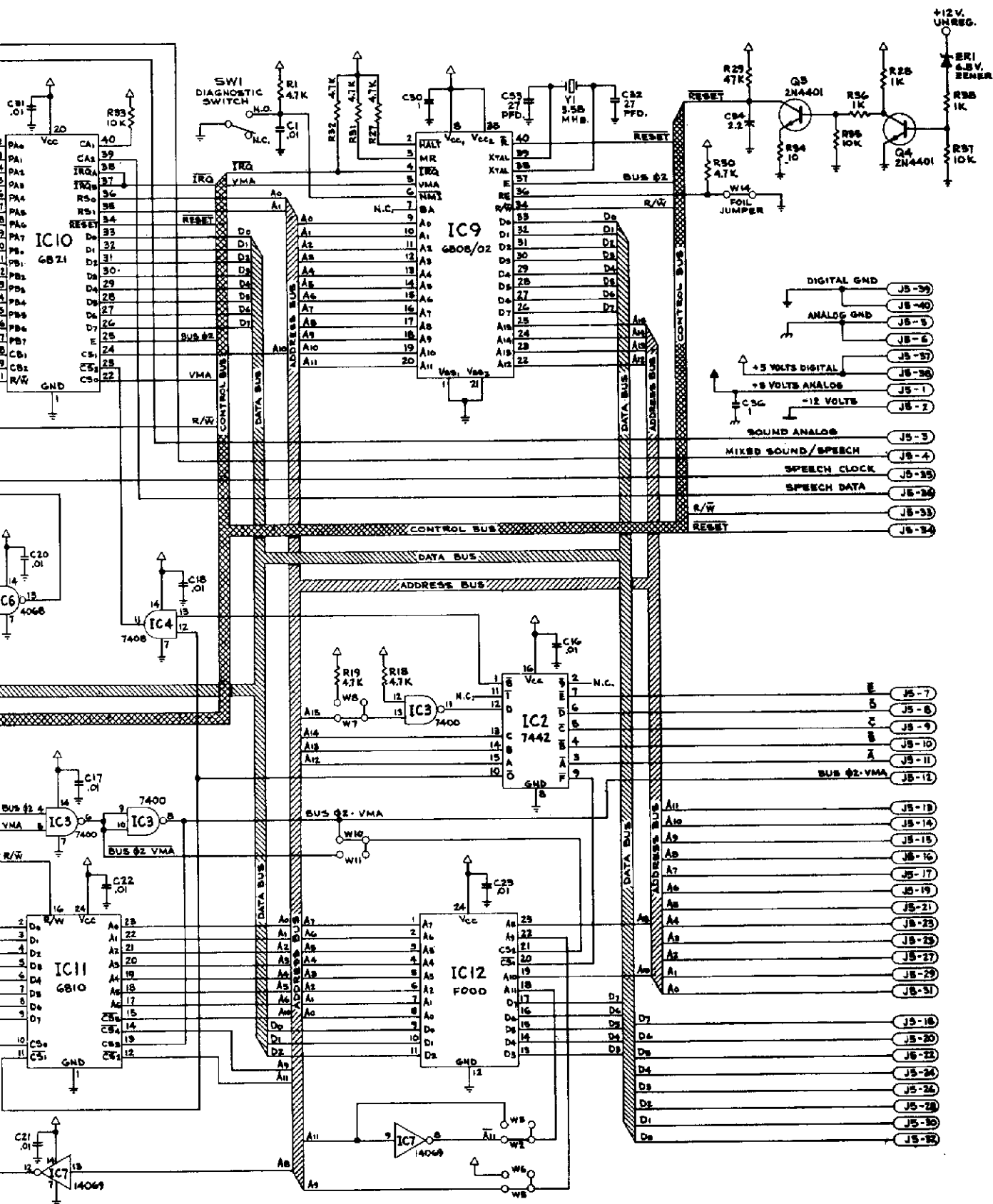

Sound Board Logic Diagram
23/24

PLAYERS *1 SCORE

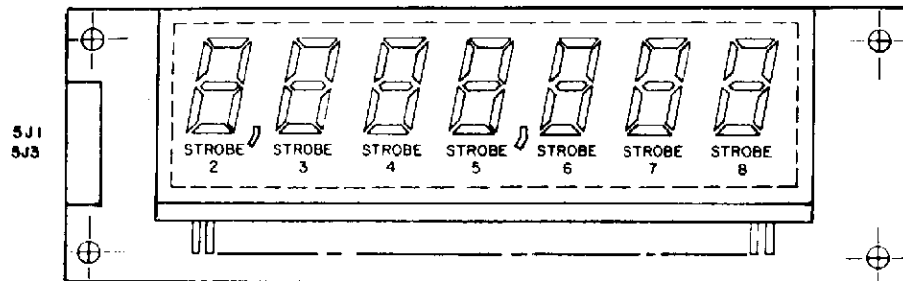

PLAYER #2 SCORE & CREDIT/BALL IN PLAY

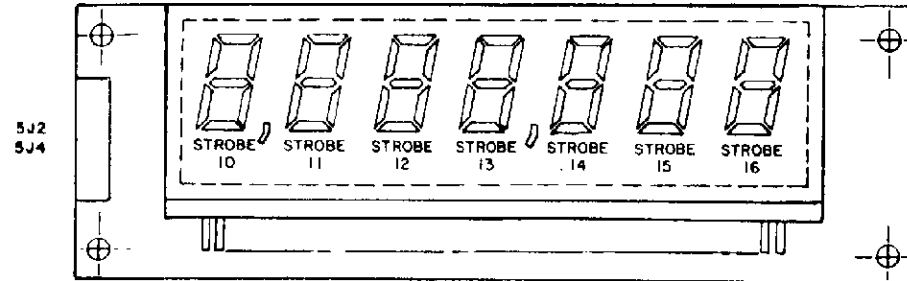

4J1/5J1 (PLAYER 1)

- 1 100,000's
- 2 -100V KEEP ALIVE
- 3 1,000,000's
- 4 f SEGMENT
- 5 N/C
- 6 g SEGMENT
- 7 +100V (N/C)
- 8 e SEGMENT
- 9 10,000's
- 10 d SEGMENT
- 11 1,000's
- 12 +100V KEEP ALIVE
- 13 100's
- 14 COMMA
- 15 10's
- 16 c SEGMENT
- 17 N/C
- 18 b SEGMENT
- 19 UNITS
- 20 a SEGMENT

4J2/5J2 (PLAYER 2)

- 1 100,000's
- 2 -100V KEEP ALIVE
- 3 1,000,000's
- 4 f' SEGMENT
- 5 N/C
- 6 g' SEGMENT
- 7 +100V (N/C)
- 8 e' SEGMENT
- 9 10,000's
- 10 d' SEGMENT
- 11 1,000's
- 12 +100V KEEP ALIVE
- 13 100's
- 14 COMMA
- 15 10's
- 16 c' SEGMENT
- 17 N/C
- 18 b' SEGMENT
- 19 UNITS
- 20 a' SEGMENT

4J8/5J5 (CREDIT/MATCH)

- 1 f' Segment (Credit)
 - 2 -100V Keep Alive
 - 3 e' Segment
 - 4 g' Segment
 - 5 c' Segment
 - 6 d' Segment
 - 7 b' Segment
 - 8 10's
 - 9 Units
 - 10 a' Segment
 - 11 e Segment
 - 12 f Segment
 - 13 10's
 - 14 d Segment
 - 15 +100V Keep Alive
 - 16 c Segment
 - 17 g Segment
 - 18 b Segment
 - 19 Units
 - 20 a Segment
- Groupings: Credit (Segments 4-7), Match (Segments 10-13), Match (Segments 16-19)

DETAIL A

4J1 - 4J4, 4J8
5J1 - 5J5
CONNECTORS

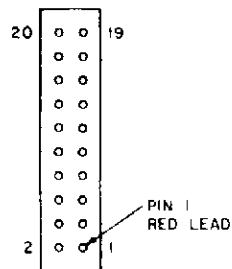

PLAYER 2 CREDIT/BALL IN PLAY

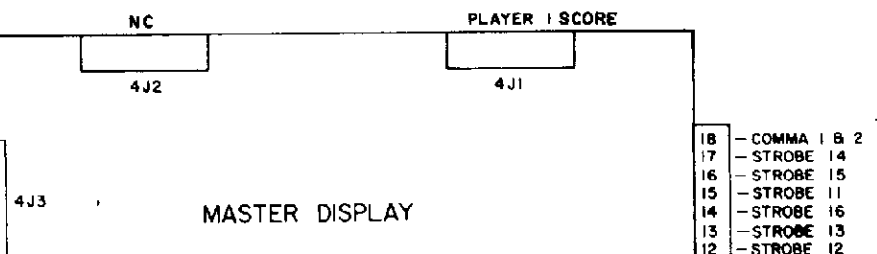

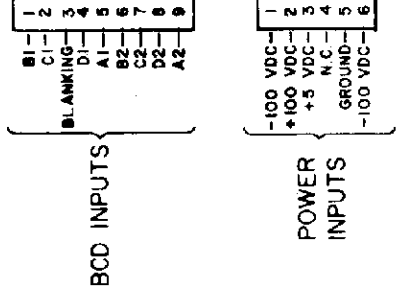
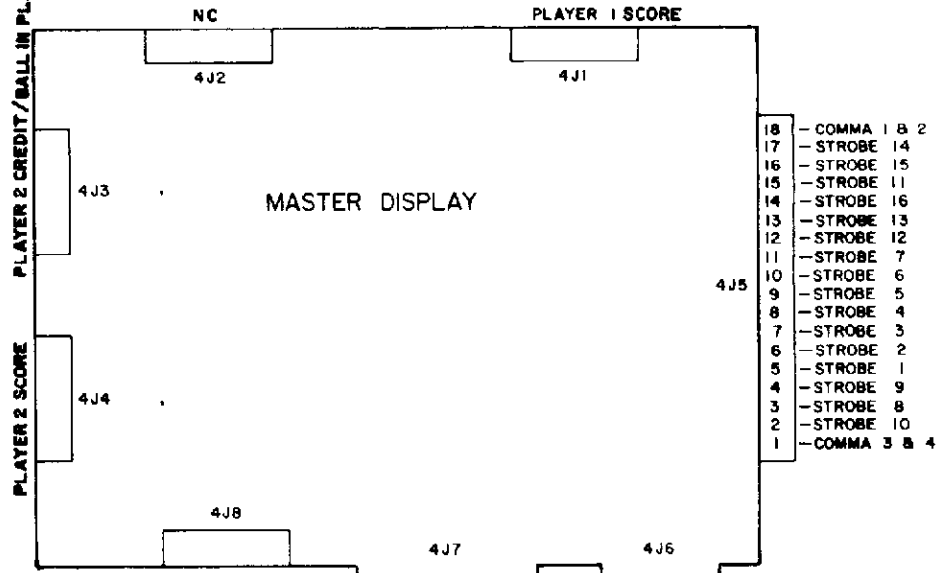

PLAYER 1 CREDITS / BALL IN PLAY

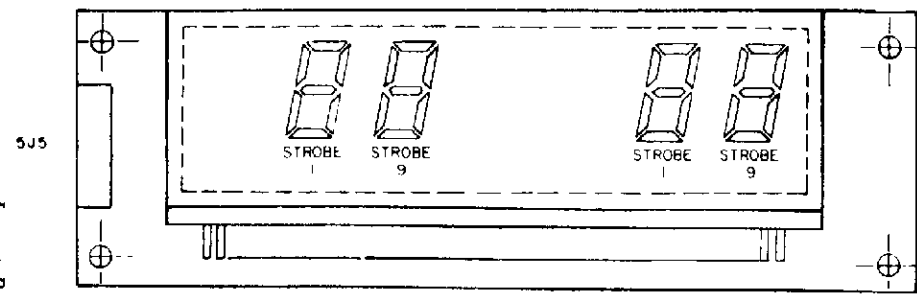

Insert Board Wiring

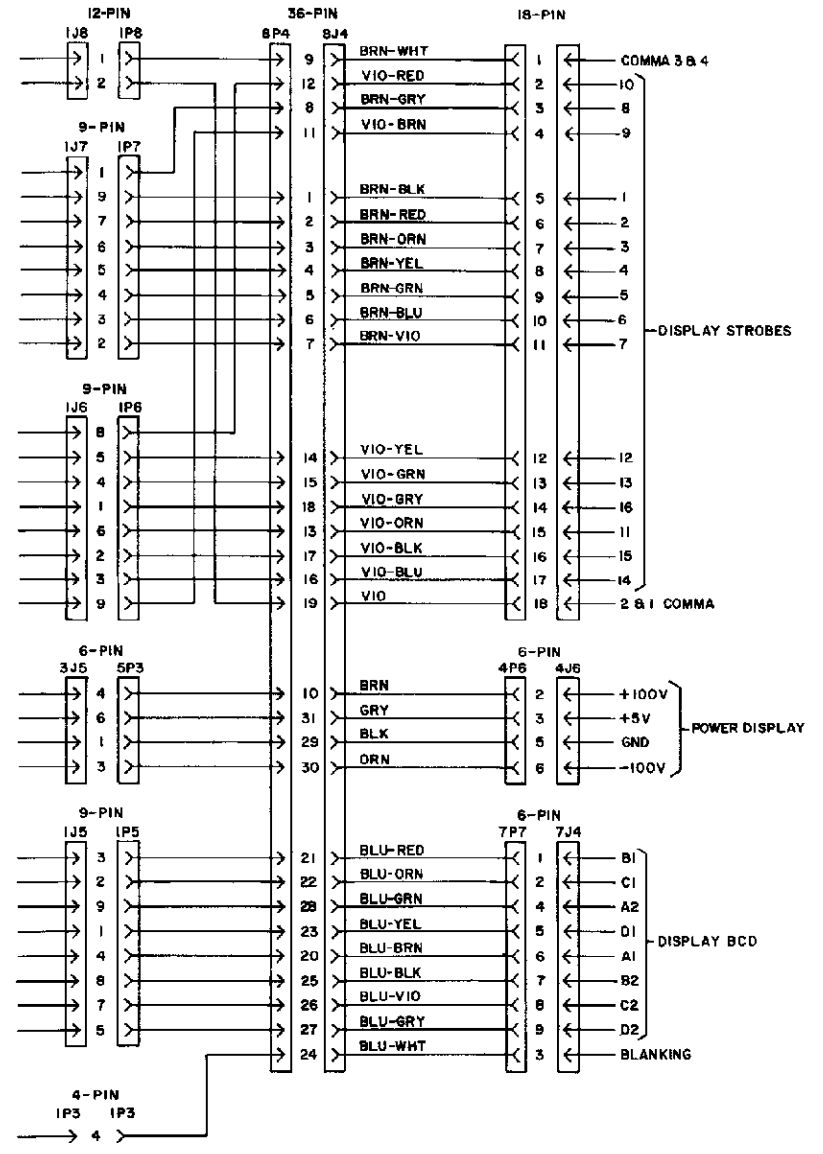

BILL OF MATERIAL

ITEM NO.	PART NO.	PART DESIGNATION	DESCRIPTION	REQ'D NO.
1	5760-09461		BARE P.C. BOARD	1
2	5310-08971	IC9, IC10, IC11	MC14069 HEX INVERTER	3
3	5310-08970	IC3, IC4	MC14543 BCD TO SEVEN SEGMENT LATCH/DECODER/DRIVER	2
4	5680-08969	IC1, IC2	UDN-7180 GAS DISCHARGE DISPLAY SEGMENT DRIVER	2
5	5680-08968	IC7, IC8, IC12, IC13	UDN-6184A OR UDN-6118A GAS DISCHARGE DISPLAY SEGMENT DR.	4
6	5310-09450	IC14	MC14081 QUAD 2-INPUT AND GATE	1
7	5010-08981	R1-R14	RESISTOR, FC, 10K OHM, 5%, 1/2 WATT	14
8	5075-09135	ØR1	IN4740A ZENER DIODE 10V, 5%, 1 WATT	1
9	5043-08980	C1, C2 C5 THRU C8	CAPACITOR, CERAMIC, 0.01 MFD., 50V, +80 -20%	6
10	5010-09035	R28, R29	RESISTOR, FC, 47K OHM, 5%, 1/4 WATT	2
11	5010-09086	R17	RESISTOR, FC, 6.8K OHM, 5%, 1/4 WATT	1
12	5010-08982	R18 THRU R27	RESISTOR, FC, 3 MEG. OHM, 5%, 1/4 WATT	10
13	5791-09437	J1 THRU J4, J8	20 PIN RIBBON HEADER	5
14	5010-09149	R15, R16	RESISTOR, FC, 15K OHM, 5%, 1/2 WATT	2
15	5010-09534	W1, W3	RESISTOR, 0 OHM	2

DIGIT CROSS REFERENCE

DIGIT	7-SEGMENT DECODER/DRIVER	STROBE (DRIVER)
Credit 10's	IC4/IC2	1 (IC13)
Credit Units	IC4/IC2	9 (IC12)
Match 10's	IC3/IC1	1 (IC7)
Match Units	IC3/IC1	9 (IC8)
#1 1,000,000's	IC3/IC1	2 (IC13)
#1 100,000's	IC3/IC1	3 (IC13)
#1 10,000's	IC3/IC1	4 (IC13)
#1 1,000's	IC3/IC1	5 (IC13)
#1 100's	IC3/IC1	6 (IC13)
#1 10's	IC3/IC1	7 (IC13)
#1 Units	IC3/IC1	8 (IC13)
#2 1,000,000's	IC3/IC1	10 (IC12)
#2 100,000's	IC3/IC1	11 (IC12)
#2 10,000's	IC3/IC1	12 (IC12)
#2 1,000's	IC3/IC1	13 (IC12)
#2 100's	IC3/IC1	14 (IC12)
#2 10's	IC3/IC1	15 (IC12)
#2 Units	IC3/IC1	16 (IC12)
#3 1,000,000's	IC4/IC2	2 (IC8)
#3 100,000's	IC4/IC2	3 (IC8)
#3 10,000's	IC4/IC2	4 (IC8)
#3 1,000's	IC4/IC2	5 (IC8)
#3 100's	IC4/IC2	6 (IC8)
#3 10's	IC4/IC2	7 (IC8)
#3 Units	IC4/IC2	8 (IC8)
#4 1,000,000's	IC4/IC2	10 (IC7)
#4 100,000's	IC4/IC2	11 (IC7)
#4 10,000's	IC4/IC2	12 (IC7)
#4 1,000's	IC4/IC2	13 (IC7)
#4 100's	IC4/IC2	14 (IC7)
#4 10's	IC4/IC2	15 (IC7)
#4 Units	IC4/IC2	16 (IC7)
#1 Comma	-/IC1	2,5 (IC13)
#2 Comma	-/IC2	10,13 (IC12)
#3 Comma	-/IC1	2,5 (IC8)
#4 Comma	-/IC2	10,13 (IC7)

DIGIT INPUT

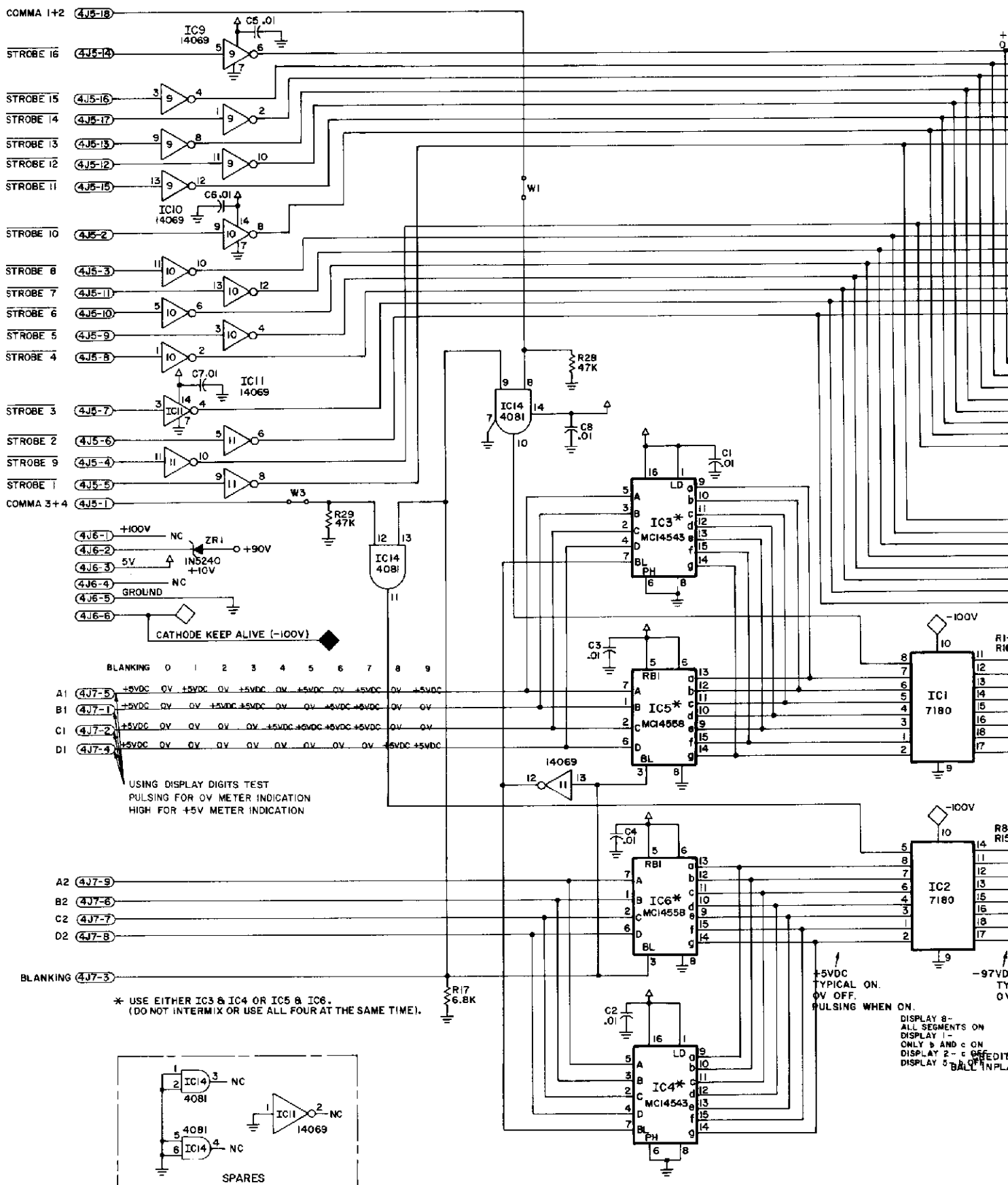

- COMMA 1+2 (4J5-18)
- STROBE 16 (4J5-14)
- STROBE 15 (4J5-16)
- STROBE 14 (4J5-17)
- STROBE 13 (4J5-13)
- STROBE 12 (4J5-12)
- STROBE 11 (4J5-15)
- STROBE 10 (4J5-2)
- STROBE 8 (4J5-3)
- STROBE 7 (4J5-11)
- STROBE 6 (4J5-10)
- STROBE 5 (4J5-9)
- STROBE 4 (4J5-8)
- STROBE 3 (4J5-7)
- STROBE 2 (4J5-6)
- STROBE 9 (4J5-4)
- STROBE 1 (4J5-5)
- COMMA 3+4 (4J5-1)

- (4J6-1) +100V NC
- (4J6-2) ZR1 +90V
- (4J6-3) 5V IN5240 +10V
- (4J6-4) NC
- (4J6-5) GROUND
- (4J6-6) CATHODE KEEP ALIVE (-100V)

	0	1	2	3	4	5	6	7	8	9
A1 (4J7-5)	+5VDC	0V	+5VDC	0V	+5VDC	0V	+5VDC	0V	+5VDC	0V
B1 (4J7-1)	+5VDC	0V	0V	+5VDC	0V	0V	+5VDC	+5VDC	0V	0V
C1 (4J7-2)	+5VDC	0V	0V	0V	+5VDC	+5VDC	+5VDC	+5VDC	0V	0V
D1 (4J7-4)	+5VDC	0V	0V	0V	0V	0V	0V	0V	+5VDC	+5VDC

USING DISPLAY DIGITS TEST
PULSING FOR 0V METER INDICATION
HIGH FOR +5V METER INDICATION

- A2 (4J7-9)
- B2 (4J7-6)
- C2 (4J7-7)
- D2 (4J7-8)

BLANKING (4J7-3)

* USE EITHER IC3 & IC4 OR IC5 & IC6.
(DO NOT INTERMIX OR USE ALL FOUR AT THE SAME TIME).

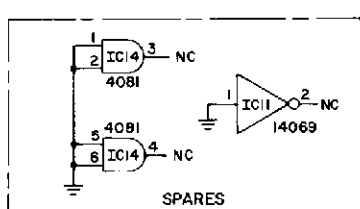

+5VDC TYPICAL ON.
0V OFF.
PULSING WHEN ON.
DISPLAY 8 - ALL SEGMENTS ON
DISPLAY 1 - ONLY b AND c ON
DISPLAY 2 - c OFF
DISPLAY 5 - BALL IN PL.

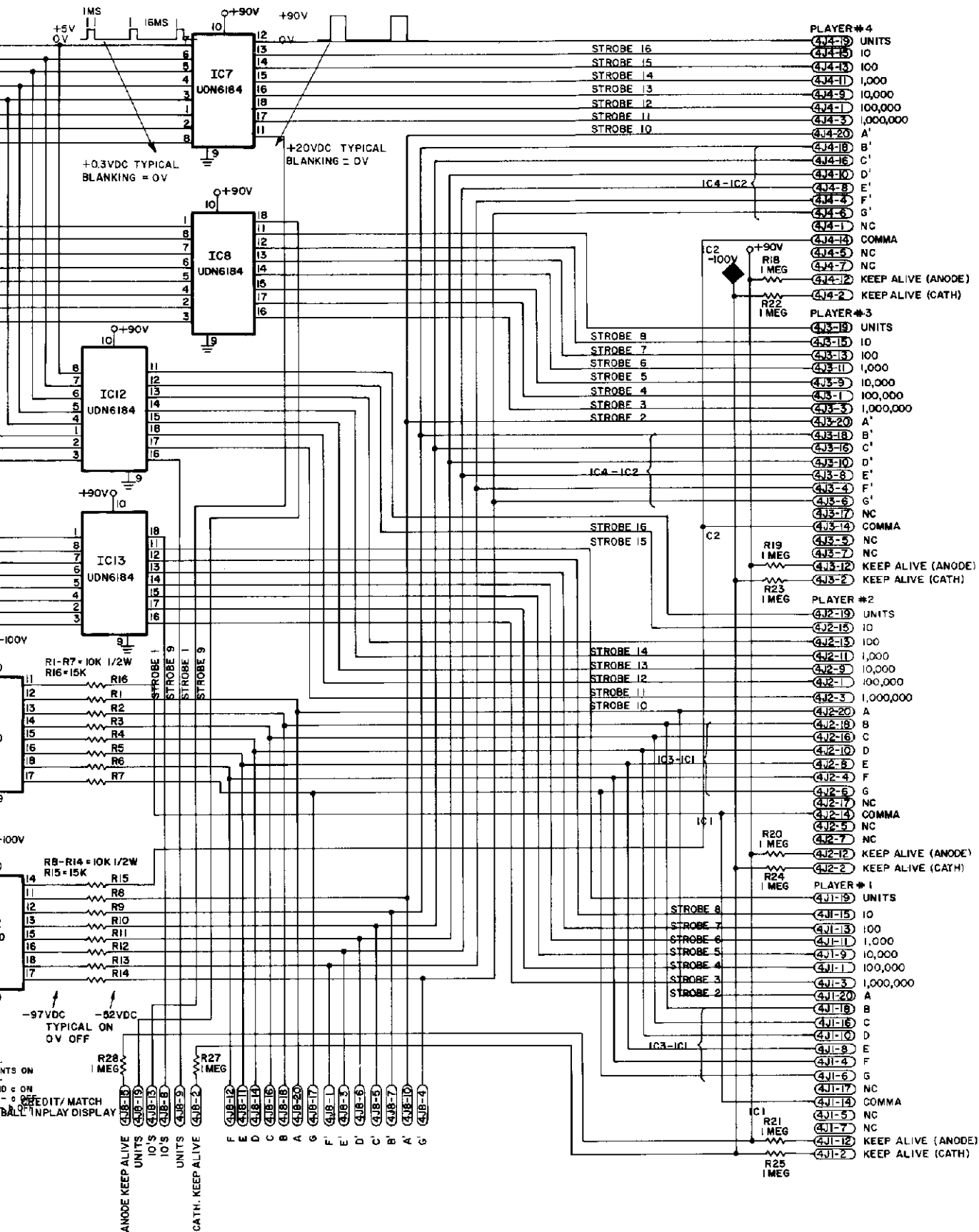

C 8363 Master Display Board Logic Diagram

BILL OF MATERIAL				
ITEM	PART NO.	PART DESIGNATION	DESCRIPTION	REQ'D.
1	5761-08458-XP		SLAVE DISPLAY P.C. BOARD	1
2	32-1645		DISPLAY MTG ADHESIVE FOAM	1
3	8470-08470-XA		7 DIGIT DISPLAY	1
4	5761-08458-XP	J1	20 PIN RIBBON HEADER	1
5	03-7613-2		CAPLUG	1

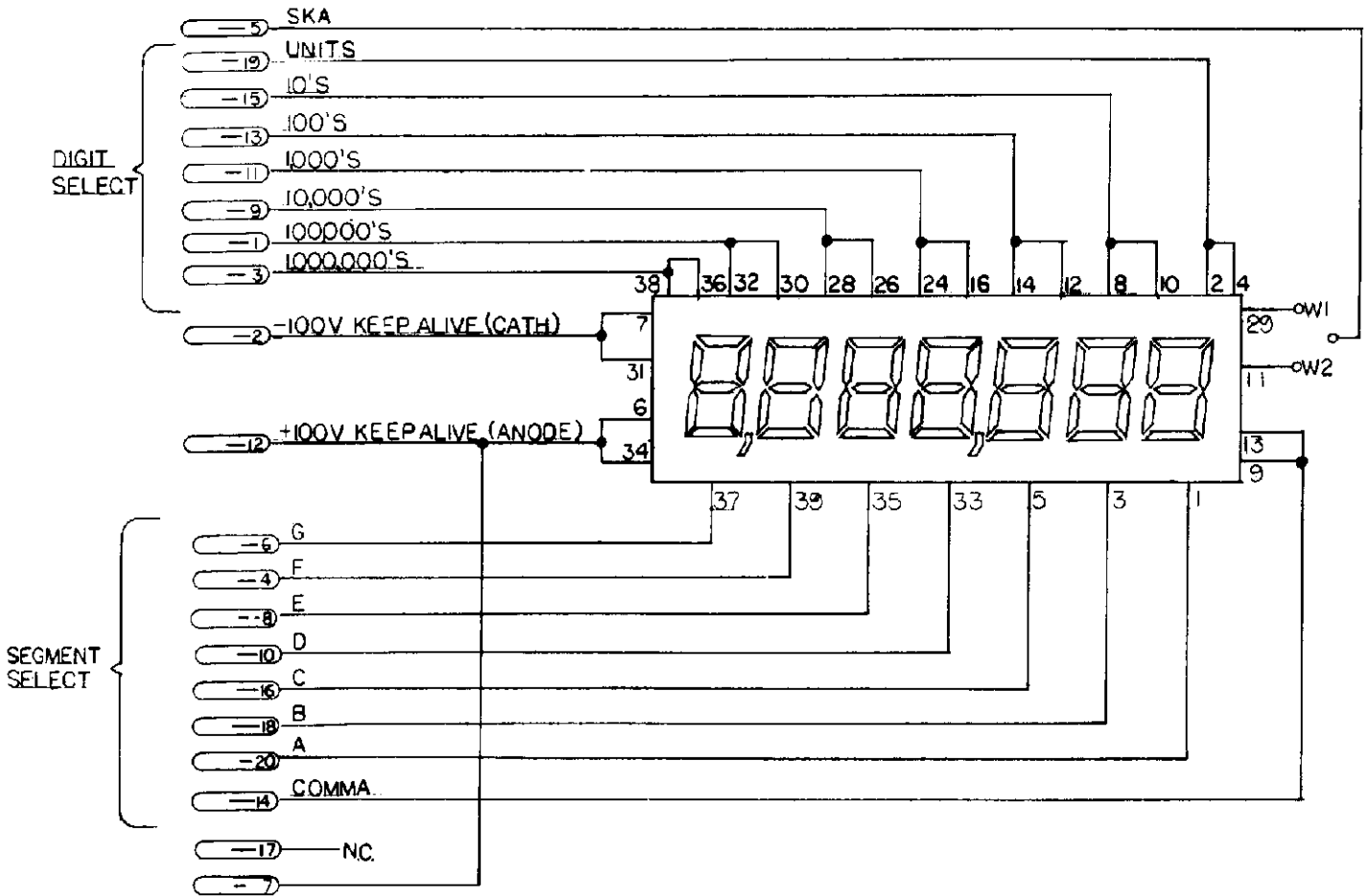
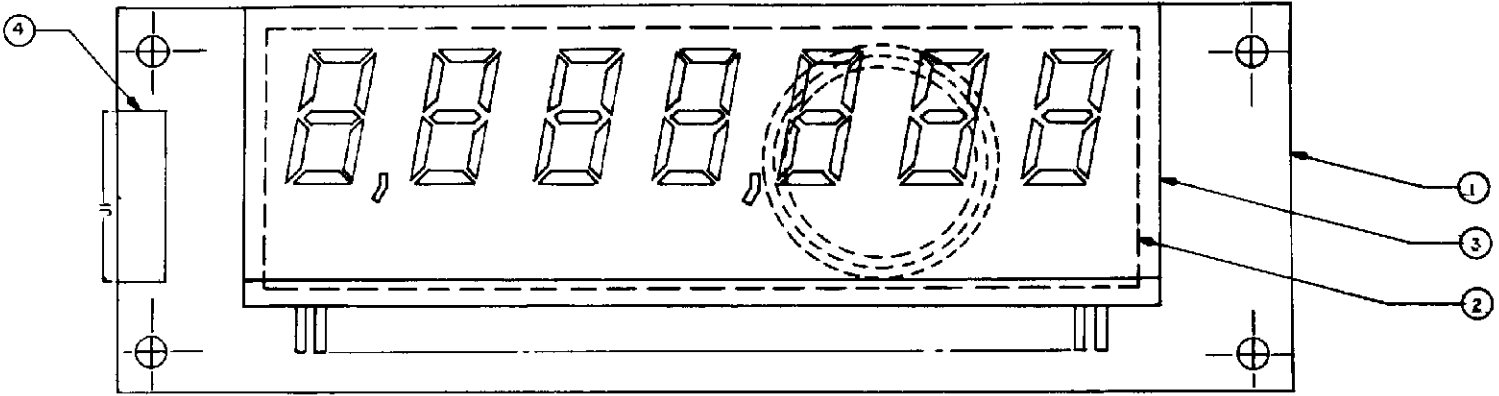

C 8364 PLAYER SLAVE DISPLAY

BILL OF MATERIAL				
ITEM	PART NO.	PART DESIGNATION	DESCRIPTION	REQ' D
1	57510246 B-00		CREDIT/MATCH SLAVE PC BOARD	1
2	23-6545		FOAM DISPLAY - BACK	1
3	5670-0844B-00		4 DIGIT DISPLAY	1
4	5751-0243B-00	J1	20 PIN RIBBON HEADER	1
5	23-6546		FOAM DISPLAY - FRONT	1
6	05-1573-2		CAP LUG	1

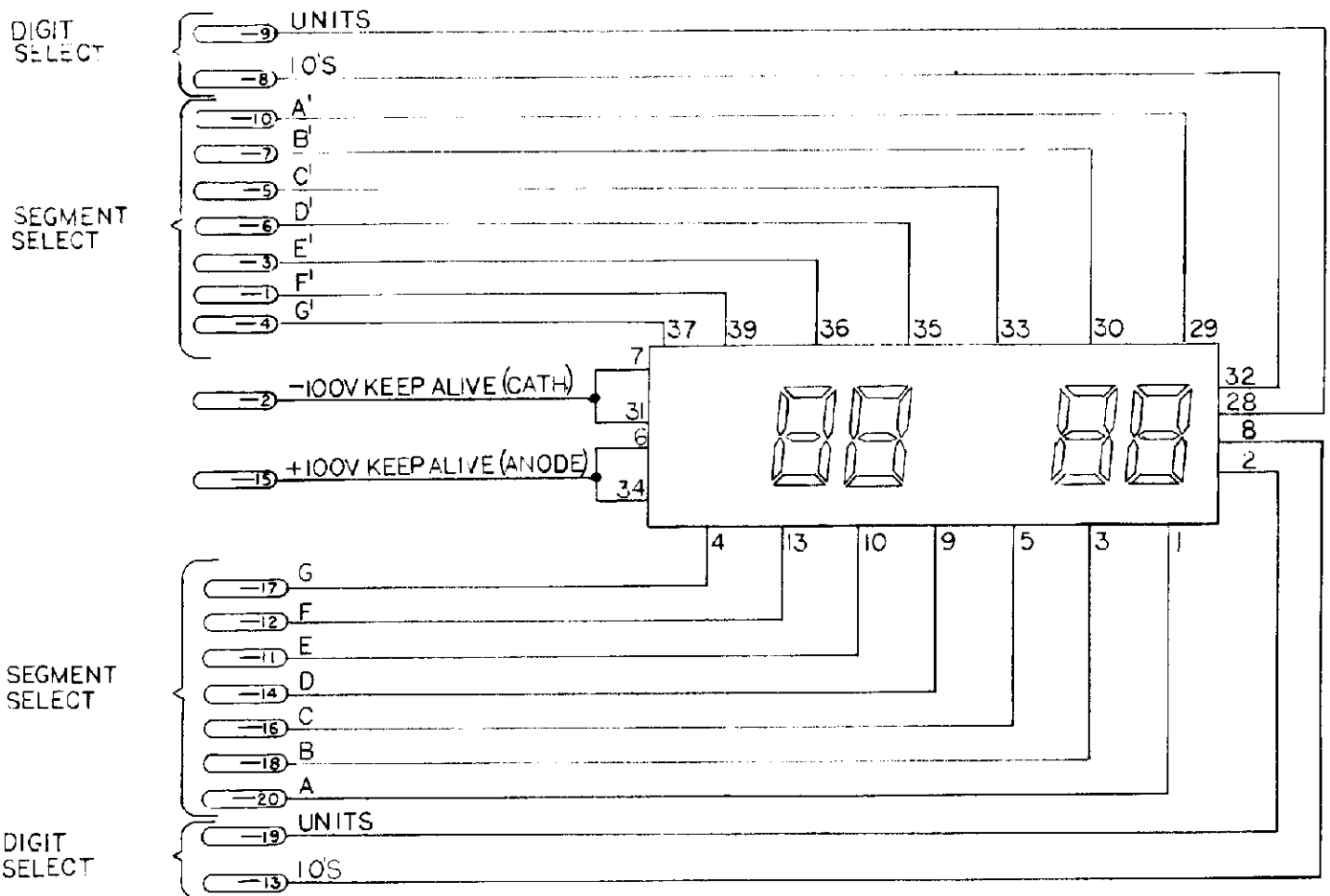
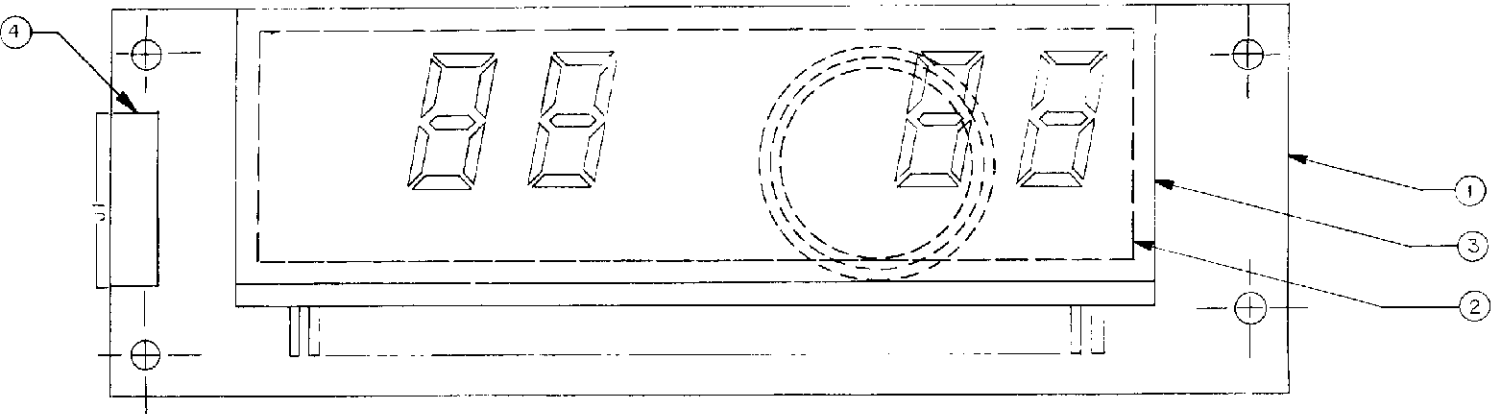

C 8365 CREDIT/MATCH SLAVE DISPLAY

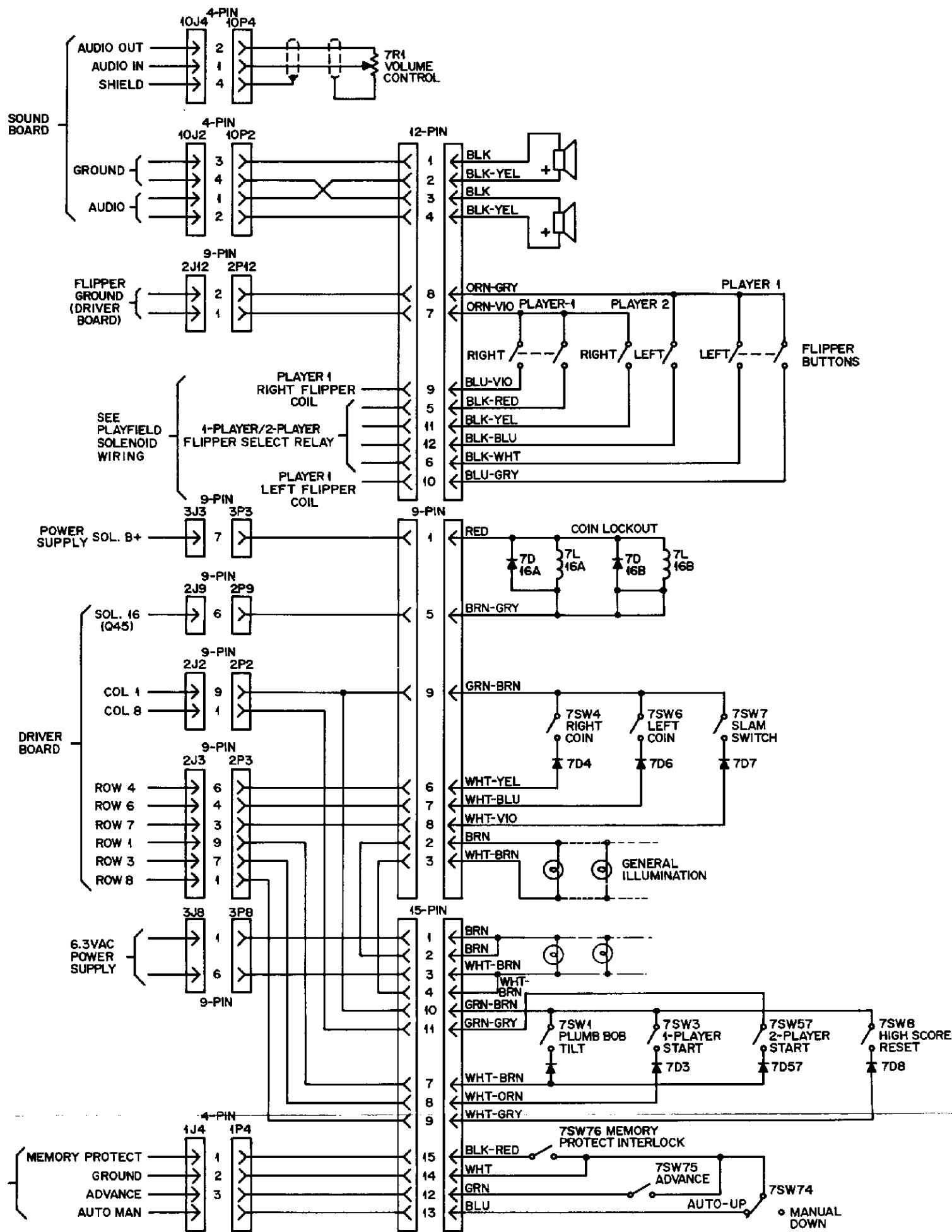

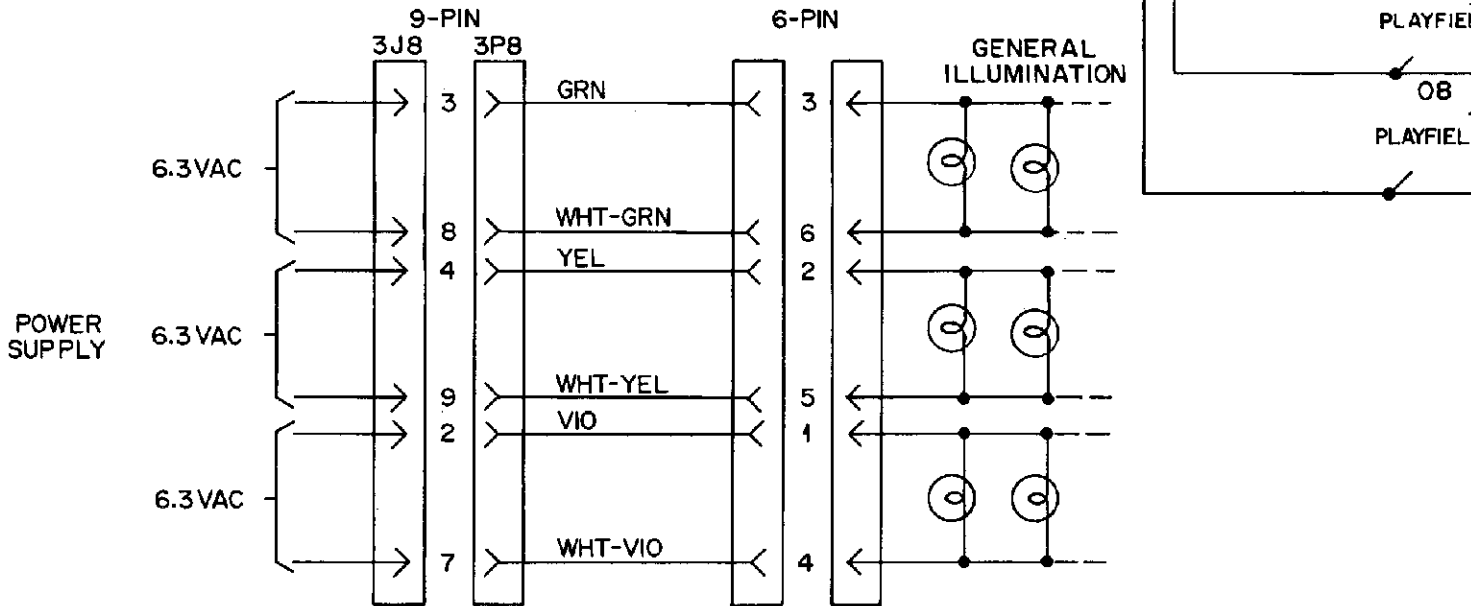
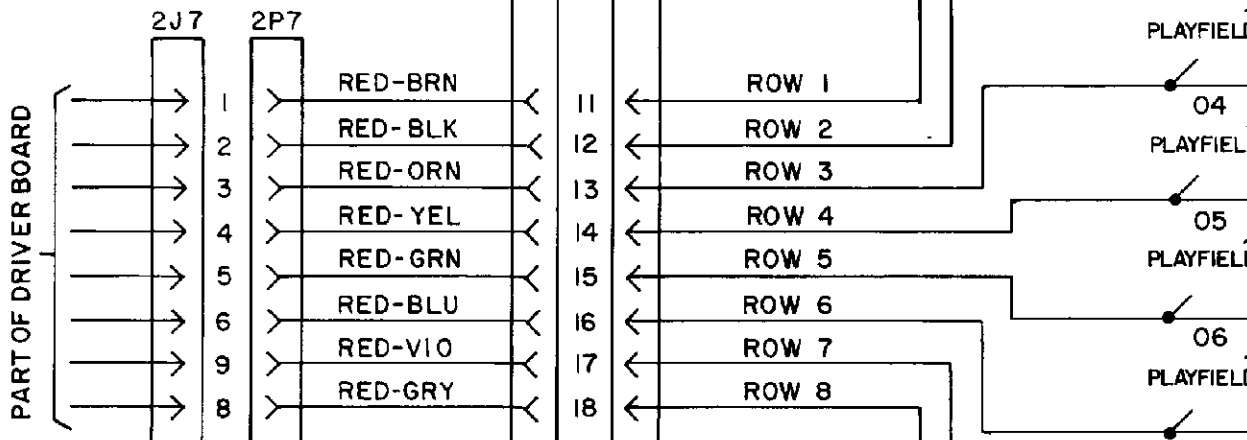
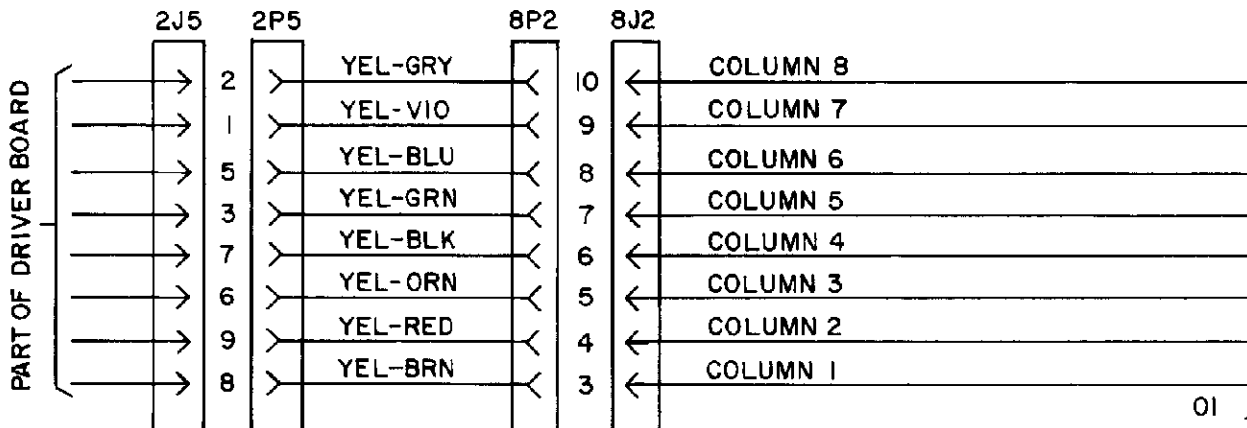

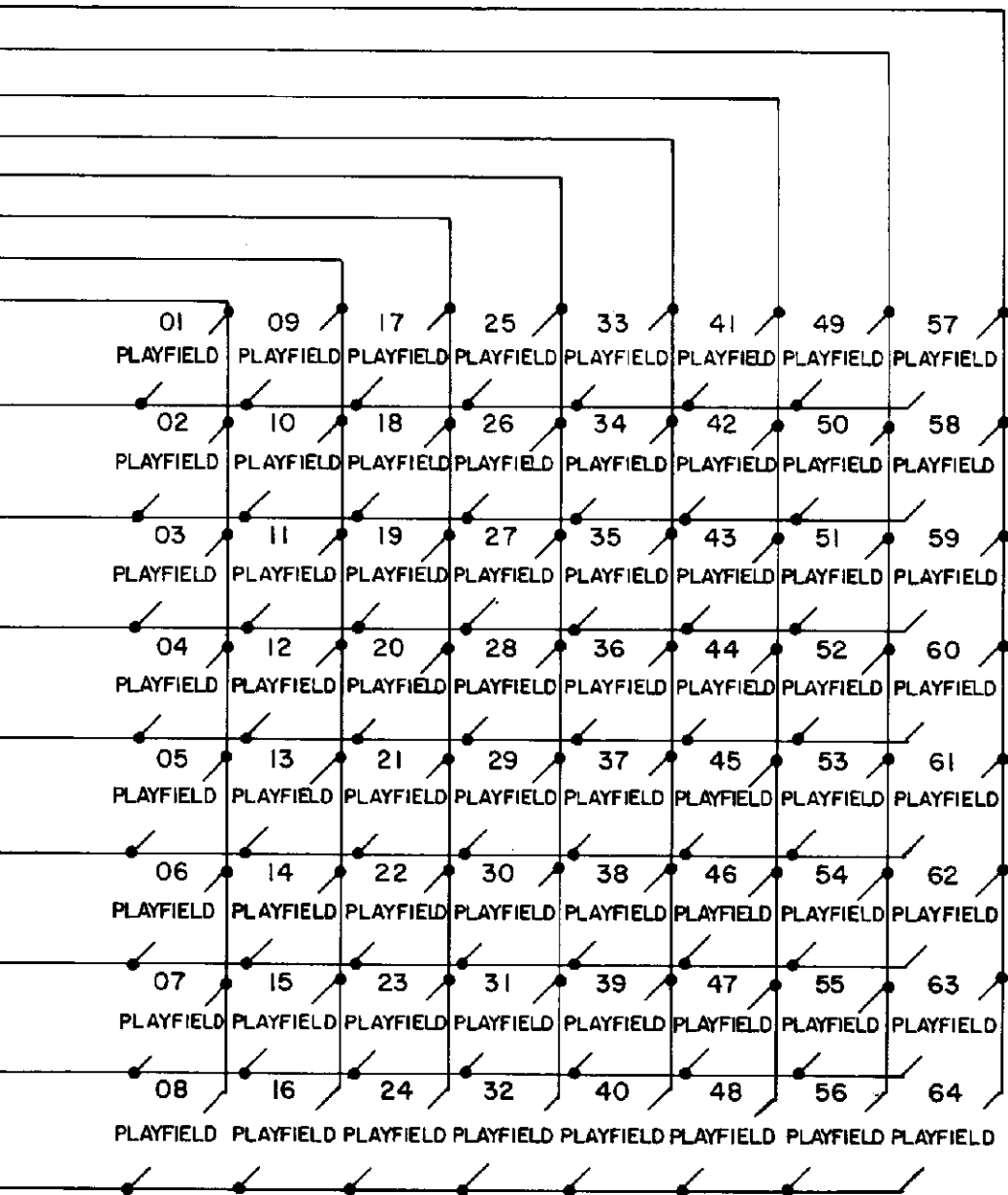
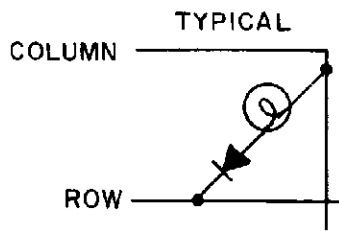

Lamp No.	Function
01	*Game Over
02	*Match
03	*Tilt
04	*HSTD
05	2x Bonus multiplier
06	3x Bonus multiplier
07	5x Bonus multiplier
08	Release
09	Right 3 Bank 50K
10	Right 3 Bank 100K
11	Right 3 Bank 150K
12	Right 3 Bank 200K
13	Disappearing target lane 40K
14	Disappearing target lane 80K
15	Disappearing target lane 160K
16	Disappearing target lane 320K
17	Hunter 1
18	Hunter 2
19	Hunter 3
20	Extra Ball
21	50K + 5 eggs
22	Eject 20K
23	Eject 30K
24	Eject 50K
25	Egg bonus 1
26	Egg bonus 2
27	Egg bonus 4
28	Egg bonus 8
29	Egg bonus 16
30	Egg bonus 32
31	Collect egg bonus
32	Spinner value 1K when lit
33	Spinner value 5K when lit
34	Unlimited balls
35	2x Bonus multiplier
36	3x Bonus multiplier
37	5x Bonus multiplier
38	Release
39	Right 3 Bank 50K
40	Right 3 Bank 100K
41	Right 3 Bank 150K
42	Right 3 Bank 200K
43	Disappearing target lane 40K
44	Disappearing target lane 80K
45	Disappearing target lane 160K
46	Disappearing target lane 320K
47	Hunter 1
48	Hunter 2
49	Hunter 3
50	Extra ball
51	50K + 5 eggs
52	Eject 20K
53	Eject 30K
54	Eject 50K
55	Egg bonus 1
56	Egg bonus 2
57	Egg bonus 4
58	Egg bonus 8
59	Egg bonus 16
60	Egg bonus 32
61	Collect egg bonus
62	Spinner value 1K when lit
63	Spinner value 5K when lit
64	Unlimited balls

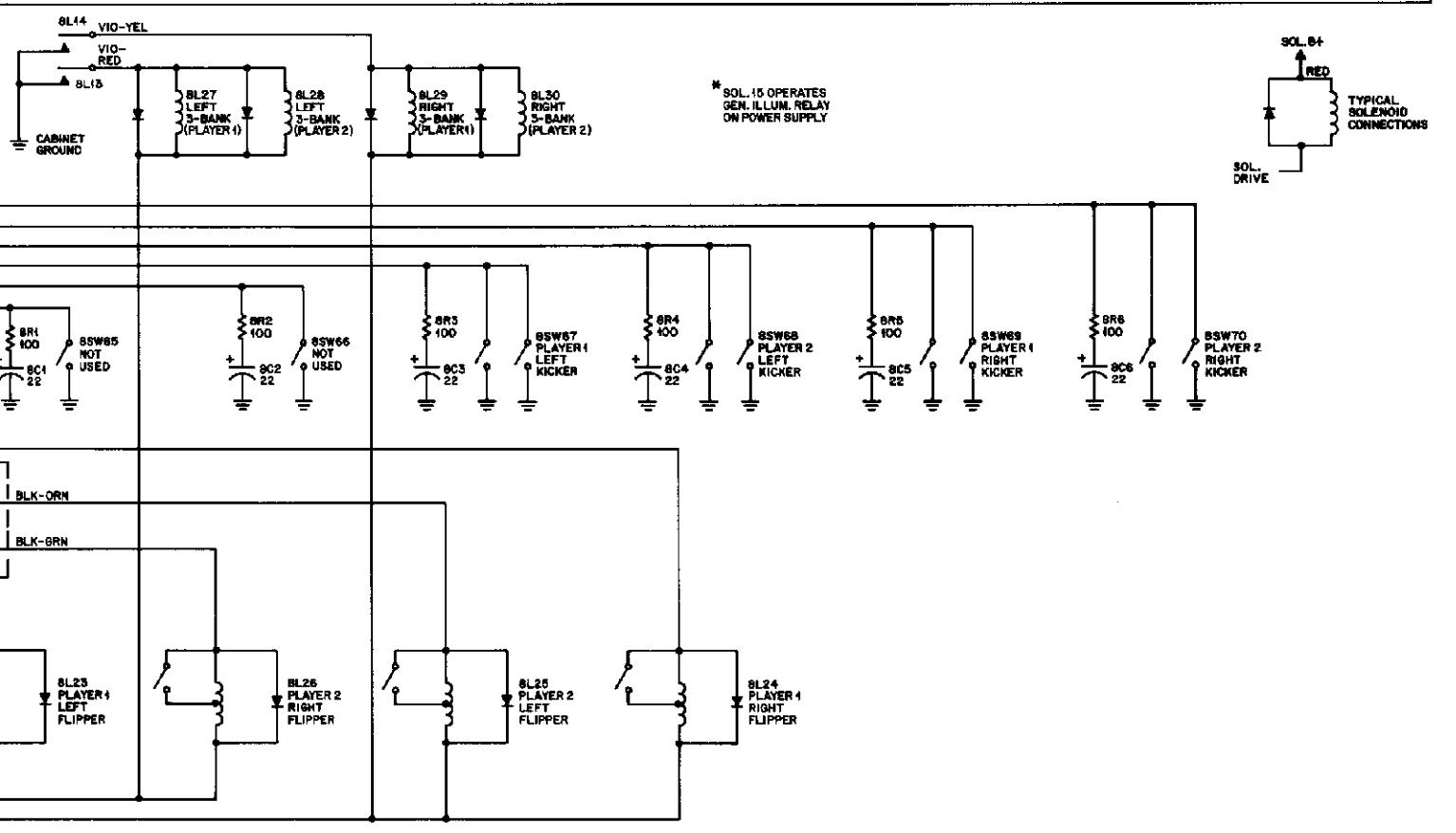
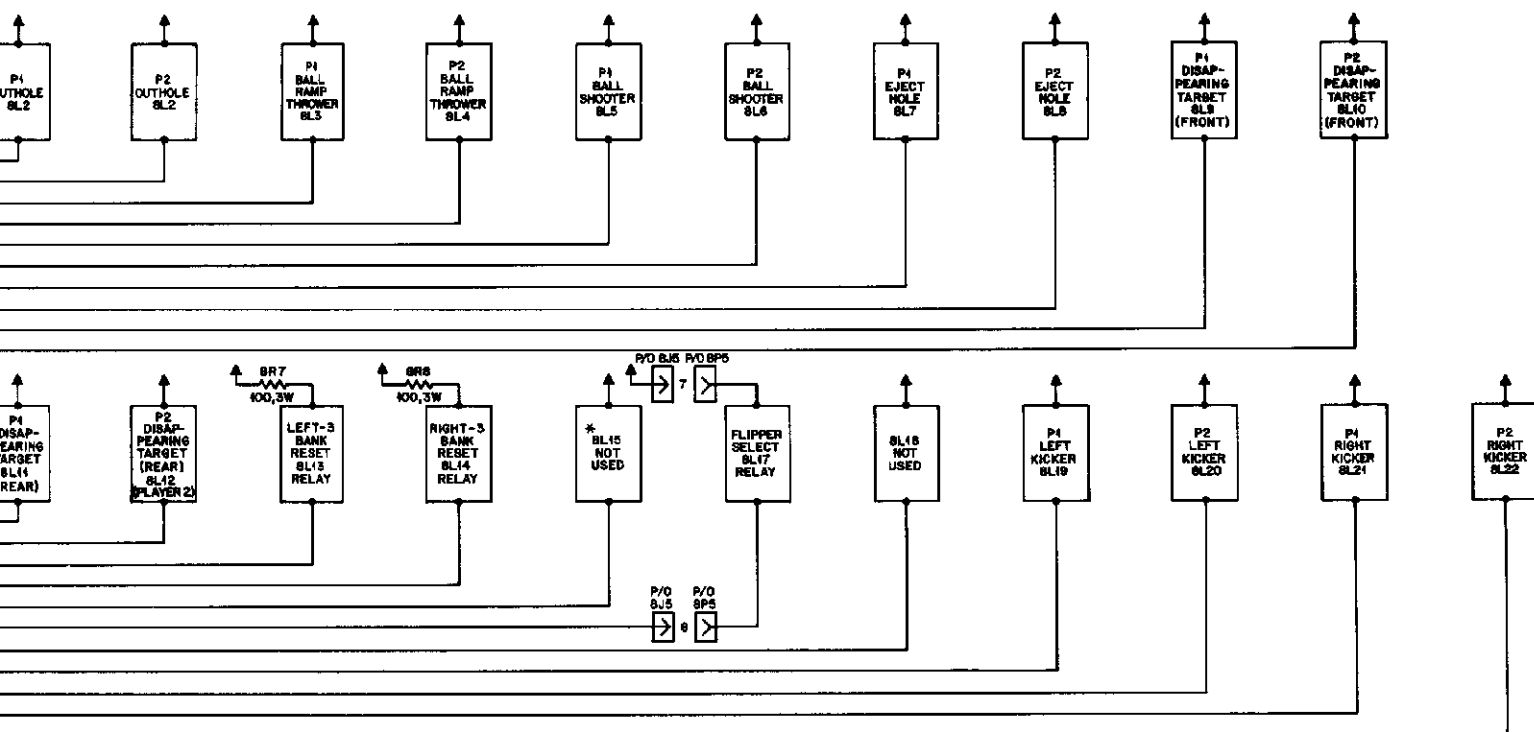

TYPIC
COLUMN

ROW

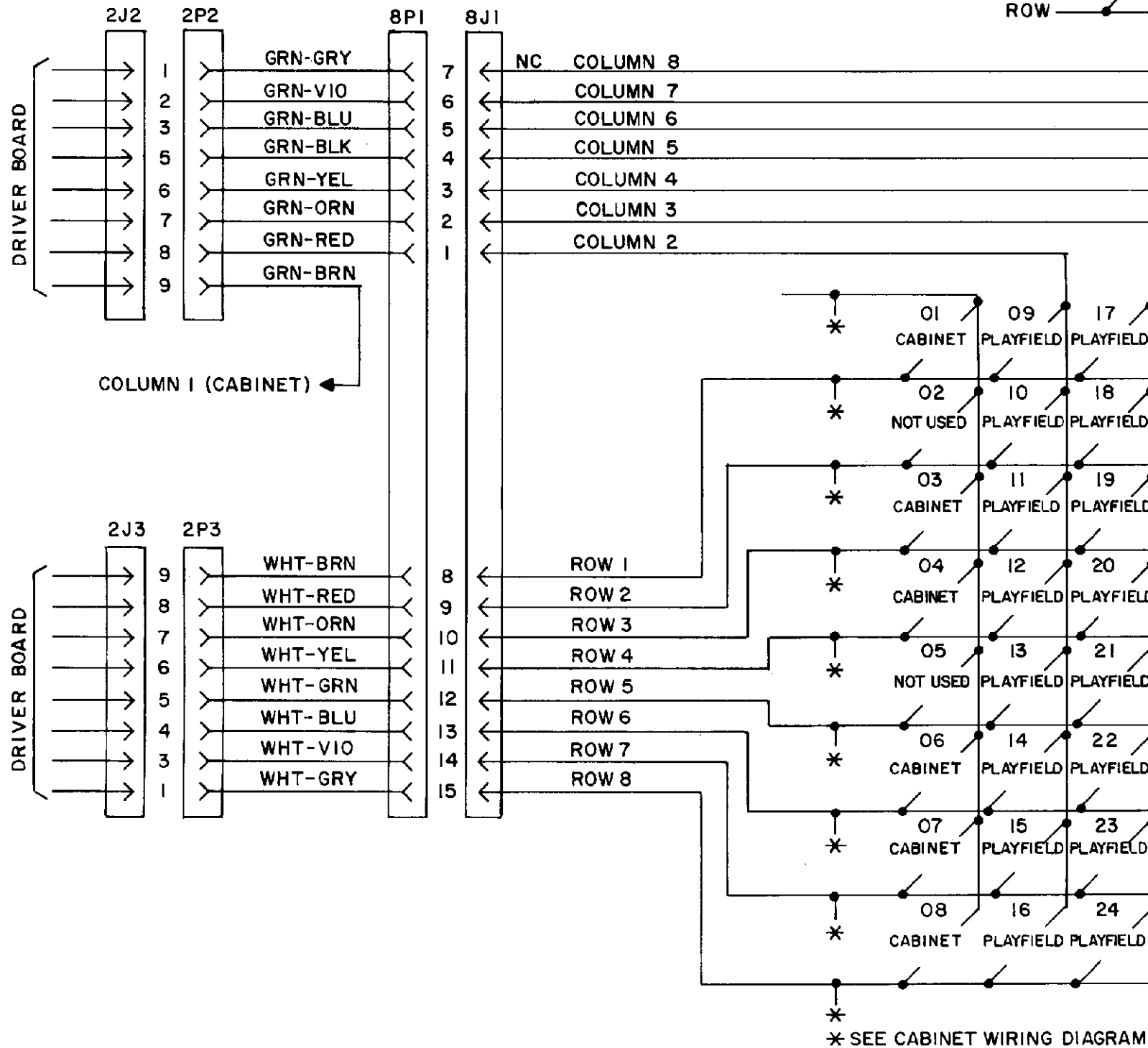

* SEE CABINET WIRING DIAGRAM

TYPICAL

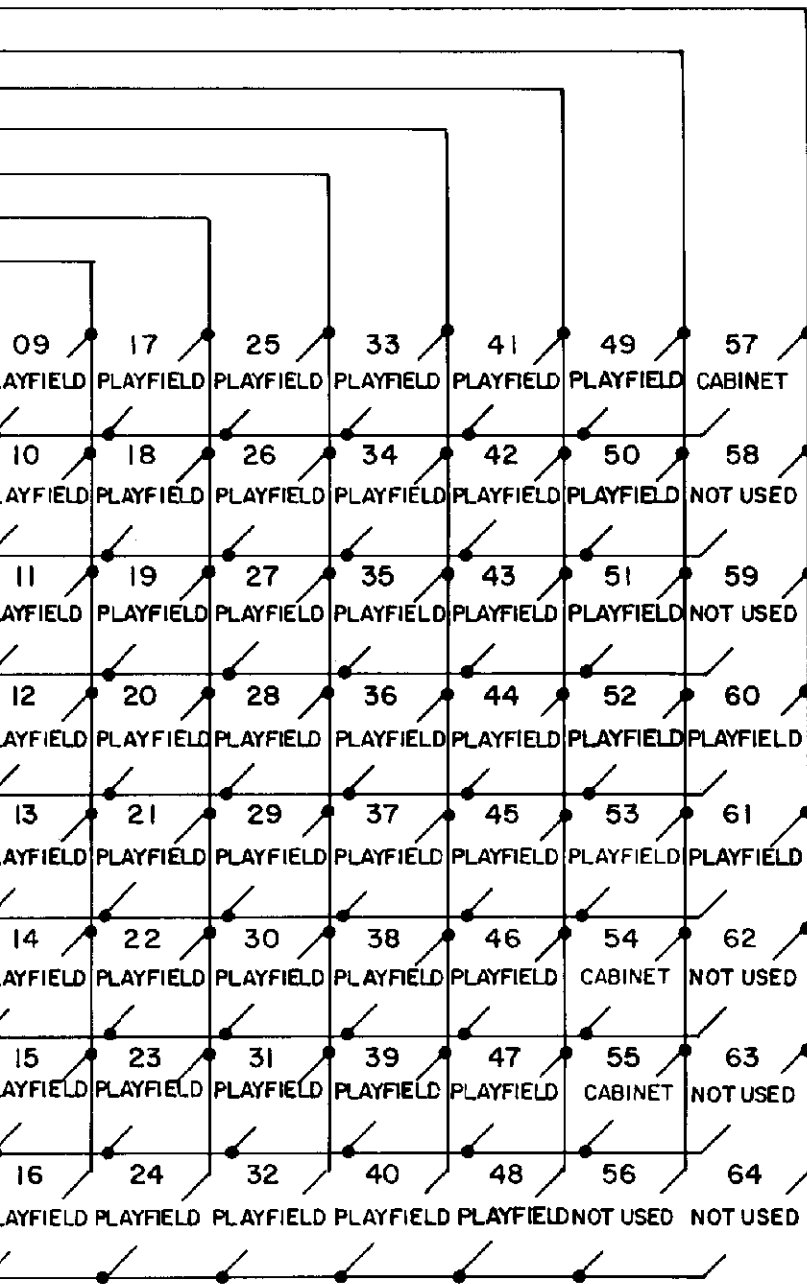
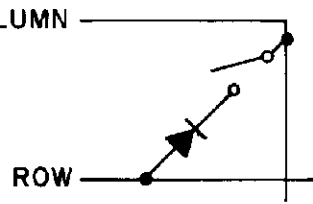

Switch

- | No. | Function* (Score) |
|-----|---|
| 01 | *Plumb bob tilt |
| 02 | Not Used |
| 03 | *1-Player Start |
| 04 | *Right coin chute |
| 05 | *Center coin chute |
| 06 | *Left coin chute |
| 07 | *Siam tilt |
| 08 | *High score reset |
| 09 | Outhole |
| 10 | Ball ramp 1 (Right) |
| 11 | Ball ramp 2 |
| 12 | Ball ramp 3 |
| 13 | Ball ramp 4 (Left) |
| 14 | Shooter lane |
| 15 | Eject Hole (5,000/lit value) |
| 16 | Spinner (100/lit value) |
| 17 | Disappearing target (Front) (3,000) |
| 18 | Disappearing target (Rear) (5,000) |
| 19 | Disappearing target rollover (8,000 + lit value) |
| 20 | Hunter rollover 1 (100) |
| 21 | Hunter bullseye 2 (100) |
| 22 | Hunter bullseye 3 (100) |
| 23 | Left 3 bank, Drop target (Left) (1,000) |
| 24 | Left 3 bank, Drop target (Center) (1,000) |
| 25 | Left 3 bank, Drop target (Right) (1,000) |
| 26 | Right 3 bank, Drop target (Left) (1,000) |
| 27 | Right 3 bank, Drop target (Center) (1,000) |
| 28 | Right 3 bank, Drop target (Right) (1,000) |
| 29 | Left kicker (10) |
| 30 | Right kicker (10) |
| 31 | Right drain rollover (10,000) |
| 32 | Not used |
| 33 | Outhole |
| 34 | Ball ramp 1 (Right) |
| 35 | Ball ramp 2 |
| 36 | Ball ramp 3 |
| 37 | Ball ramp 4 (Left) |
| 38 | Shooter lane |
| 39 | Eject Hole (5,000/lit value) |
| 40 | Spinner (100/lit value) |
| 41 | Disappearing target (Front) (3,000) |
| 42 | Disappearing target (Rear) (5,000) |
| 43 | Disappearing target rollover (8,000 + lit value) |
| 44 | Hunter rollover 1 (100) |
| 45 | Hunter rollover 2 (100) |
| 46 | Hunter rollover 3 (100) |
| 47 | Left 3 bank, Drop target (Left) (1,000) |
| 48 | Left 3 bank, Drop target (Center) (1,000) |
| 49 | Left 3 bank, Drop target (Right) (1,000) |
| 50 | Right 3 bank, Drop target (Left) (1,000) |
| 51 | Right 3 bank, Drop target (Center) (1,000) |
| 52 | Right 3 bank, Drop target (Right) (1,000) |
| 53 | Left kicker (10) |
| 54 | Right kicker (10) |
| 55 | Right drain rollover (10,000) |
| 56 | Not used |
| 57 | *2-Player Start |
| 58 | **P1 Left flap |
| 59 | **P1 Right flap |
| 60 | **P2 Left flap |
| 61 | **P2 Right flap |

PLAYER 1

PLAYER 2

Note: Score value in parenthesis

*Switches located in cabinet

**Switches located on flipper assemblies and only produce sounds.

WIRING DIAGRAM FOR CONNECTIONS FOR CABINET SWITCHES.