

*Bally*®

SEPTEMBER 1996  
16-50048-101  
FINAL

# SCARED STIFF™



**Operations Manual Includes:**

Operations & Adjustments • Testing & Problem Diagnosis • Parts Information  
Reference Diagrams & Schematics

Midway Manufacturing Company, 3401 North California Avenue, Chicago, Illinois 60618

# DIP SWITCH SETTINGS AND JUMPERS

EPROM Jumper Settings for G11	W1	W2
1MEG, 2MEG, 4 MEG EPROM	In	Out

## Dip Switch Chart

Country	SW1	SW2	SW3	SW4	SW5	SW6	SW7	SW8
America	Off	Off	On	On	On	On	On	On
European	Off	Off	On	On	On	Off	On	On
French	Off	Off	On	On	On	On	Off	Off
German	Off	Off	On	On	On	On	On	Off
Spain	Off	Off	On	On	Off	On	On	On

## SOLENOID/FLASHER TABLE

Sol. No.	Function	Solenoid Type	Voltage Connections			Drive Xister	Drive Connections			Drive Wire Color	Solenoid Part number	
			Playfield	Backbox	Cabinet		Playfield	Backbox	Cabinet		Flashlamp Type	Playfield
01	AUTO PLUNGER	High Power	J133-2			Q72	J116-1			Vio-Brn	AE-23-800	
02	LOOP GATE	High Power	J133-2			Q68	J116-2			Vio-Red	A-14406	
03	RIGHT POPPER	High Power	J133-2			Q71	J116-4			Vio-Org	AE-24-900	
04	COFFIN POPPER	High Power	J133-2			Q67	J116-5			Vio-Yel	AE-23-800	
05	COFFIN DOOR	High Power	J133-2			Q70	J116-6			Vio-Grn	AE-26-1500	
06	CRATE KICKOUT	High Power	J133-2			Q66	J116-7			Vio-Blu	AE-24-900	
07	*KNOCKER	High Power		J133-2		Q69		J116-8		Vio-Blk		AE-23-800
08	CRATE POST POWER	High Power	J133-2			Q65	J116-9			Vio-Gry	FL-11629	
09	TROUGH EJECT	Low Power	J133-3			Q44	J113-1			Brn-Blk	AE-26-1500	
10	LEFT SLING	Low Power	J133-3			Q48	J113-3			Brn-Red	AE-25-1000	
11	RIGHT SLING	Low Power	J133-3			Q43	J113-4			Brn-Org	AE-25-1000	
12	CENTER JET	Low Power	J133-3			Q47	J113-5			Brn-Yel	AE-26-1200	
13	UPPER JET	Low Power	J133-3			Q42	J113-6			Brn-Grn	AE-26-1200	
14	LOWER JET	Low Power	J133-3			Q46	J113-7			Brn-Blu	AE-26-1200	
15	UPPER SLINGSHOT	Low Power	J133-3			Q41	J113-8			Brn-Vio	AE-26-1200	
16	CRATE POST HOLD	Low Power	J133-2			Q45	J113-9			Brn-Gry	FL-11629	
17	TOP JET FLASHER	Flasher	J133-6	J134-5		Q28	J111-1	J112-1		Blk-Brn	24-8802	24-8704
18	MIDDLE JET FLASHER	Flasher	J133-6	J134-5		Q32	J111-2	J112-2		Blk-Red	24-8802	24-8704
19	LOWER JET FLASHER	Flasher	J133-6	J134-5		Q27	J111-3	J112-3		Blk-Org	24-8802	24-8704
20	PLAYFIELD BOLTS	Flasher	J133-6			Q31	J111-4			Blk-Yel	24-8704 (2)	
21	SKULL FLASHER LEFT	Flasher	J133-6			Q26	J111-5			Blu-Grn	24-8802	
22	UPPER RIGHT FLASHER	Flasher	J133-6			Q30	J111-6			Blu-Blk	24-8802	
23	LEFT RAMP FLASHER	Flasher	J133-6			Q25	J111-7			Blu-Vio	24-8802	
24	CENTER LEFT FLASHER	Flasher	J133-6			Q29	J111-8			Blu-Gry	24-8802	
25	SKULL FLASHER RIGHT	Gen. Purpose	J133-6			Q16	J109-1			Blu-Brn	24-8802	
26	CENTER TV	Gen. Purpose	J133-6	J134-5		Q15	J109-2	J107-3		Blu-Red	24-8802	24-8704
27	UPPER LEFT FLASHER	Gen. Purpose	J133-6			Q14	J109-3			Blu-Org	24-8802	
28	CENTER RIGHT FLASHER	Gen. Purpose	J133-6			Q13	J109-4			Blu-Yel	24-8802	
33	LEFT DIVERTER POWER	High Power	J119-6,7			Q84	J120-6			Yel-Vio	A-20099	
34	LEFT DIVERTER HOLD	Low Power	J119-6,7			Q86	J120-4			Org-Vio	A-20099	
35	LOWER LEFT FLASHER	High Power	J133-6			Q81	J120-3			Yel-Gry	24-8802	
36	LOWER RIGHT FLASHER	Low Power	J133-6			Q83	J120-1			Org-Gry	24-8802	
37	**AUX LAMP CLOCK	oL.P.D.C.	J141-2				J110-1			Brn-Wht	A-20781	
38	**AUX LAMP DATA	oL.P.D.C.	J141-2				J110-3			Org-Wht	A-20781	
39	*SPIDER WHEEL 1 (1.8V)	oL.P.D.C.		J141-2				J110-4		Yel-Wht		14-8024
40	*SPIDER WHEEL 2 (1.8V)	oL.P.D.C.		J141-2				J110-5		Grn-Wht		14-8024

### General Illumination

01	UPPER PLAYFIELD	G.I.	J105-1			Q5	J105-7			Wht-Brn	24-6549	
02	CENTER PLAYFIELD	G.I.	J105-2			Q4	J105-8			Wht-Org	24-6549	
03	LOWER PLAYFIELD	G.I.	J105-3			Q3	J105-9			Wht-Yel	24-6549	
04	† ILLUM. STRING 4	G.I.		J106-7		Q2		J106-10		Wht-Grn		24-6549
05	† ILLUM. STRING 5	G.I.		J106-6		Q1		J106-11		Wht-Vio		24-6549

### Flipper Circuits

		Voltage Connections		Drive Transistors		Drive Connectors		Drive Wire Colors		Coil Part No.	Coil Color
		Playfield	Power Hold	Power	Hold	Playfield	Power	Hold			
29		Lwr. Rt. Power	J119-1 (Red-Grn)	Q90		J120-13		Yel-Grn			
30	Lower Right Flipper	Lwr. Rt. Hold	J119-1 (Red-Grn)		Q92	J120-11		Org-Grn		FL-11629	BLUE
31		Lwr. Lt. Power	J119-4 (Red-Blu)	Q87		J120-9		Yel-Blu			
32	Lower Left Flipper	Lwr. Lt. Hold	J119-4 (Red-Blu)		Q89	J120-7		Org-Blu		FL-11629	BLUE
33		Upr. Rt. Power	J119-6 (Red-Vio)	Q84		J120-6		Yel-Vio		SEE	ABOVE
34	Upper Right Flipper	Upr. Rt. Hold	J119-6 (Red-Vio)		Q86	J120-4		Org-Vio		SEE	ABOVE
35		Upr. Lt. Power	J119-8 (Red-Gry)	Q81		J120-3		Yel-Gry		SEE	ABOVE
36	Upper Left Flipper	Upr. Lt. Hold	J119-8 (Red-Gry)		Q83	J120-1		Org-Gry		SEE	ABOVE

† ILLUM. = Power Driver Board; 24-6549=#44 bulb; 24-8704=#89 bulb; 24-8768=#555 bulb; 24-8802=#906 bulb oL.P.D.C. = Low Power Device Controls

† These G.I. strings do not brighten and dim, they are always ON. \* Located in Backbox \*\* Located under playfield

# DECLARATION OF CONFORMITY

**MIDWAY MANUFACTURING CO., INC.**

3401 N. CALIFORNIA AVE.  
CHICAGO, IL 60618  
U.S.A.

**WE, HEREBY DECLARE UNDER SOLE RESPONSIBILITY THAT**

**THE MODEL: "SCARED STIFF" 50248, 50348, 50448, 50748, 50948, 51048,  
51148, 51348, 51448, 51848, 52048, 52148, 52248, 52348, 57248 (PINBALL)**

**TO WHICH THIS DECLARATION RELATES IS IN CONFORMITY WITH THE  
FOLLOWING EUROPEAN PRODUCT SAFETY DIRECTIVES:**

**ELECTROMAGNETIC COMPATABILITY DIRECTIVE**  
**(89/336/EEC AND AMENDMENTS 91/C162/08, 92/31/EEC, 93/68/EEC**

**AS IS VERIFIED BY COMPLIANCE WITH THE FOLLOWING STANDARDS:**

EN 55014:1993 EN55104:1995 EN61000-4-2: 1995  
IEC 801-3: 1984 (EN61000-4-3 ) EN61000-4-4: 1995 EN61000-4-5: 1995  
ENV50141: 1993 (EN61000-4-6 ) EN61000-4-11: 1994

Date issued:

JULY 2, 1996

**MANUFACTURE'S SIGNATURE**

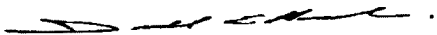

**DON HASSLER**

**V.P. MANUFACTURING**

# ATTENTION

This game uses a Security CPU Board that is not downward compatible to the CPU boards used in previous games. The board has an added security chip that can be interchanged between other Scared Stiff games and software revision levels. The CPU board itself is interchangeable with later model games, but must be equipped with the correct security chip and software for that specific game.

The games' electronic ID number is shown in the display during power-up. The number displayed is the same nine digit number printed on the security chip label. The first three digits are the project number without a country specific code. An example of the power-up display is shown below, the electronic ID number is bolded.

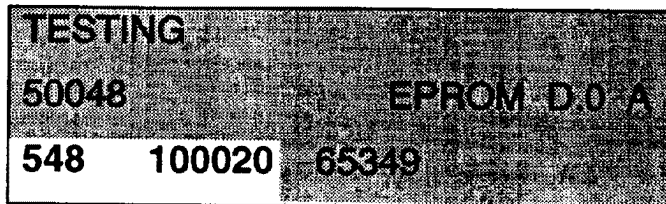

# IMPORTANT NOTICE

## PLEASE READ

This pinball game is equipped with a SAFETY FEATURE to prevent shocks from the solenoid circuit when the coin door is open. An interlock switch assembly (part no. A-18249-1), located at the left of the coin door opening, has been added to the game. This assembly is a bracket containing the existing memory protect switch on the bottom and a new interlock switch on the top. When the coin door is open, the new interlock switch opens, breaking the connection to the +50V and +20V winding of the transformer secondary.

A special tool called the Service Switch Actuator is provided for the serviceman/technician that repairs the game. This tool is painted yellow and located in a bag stapled inside the cabinet. The Service Switch Actuator slips over the interlock switch and holds it closed while the coin door is open, allowing the serviceman to test and repair the solenoid circuit.

Hold the top interlock switch in, then slide the short end of the Service Switch Actuator over the top of the interlock switch bracket and the long end over the center of the switch plunger to hold it in.

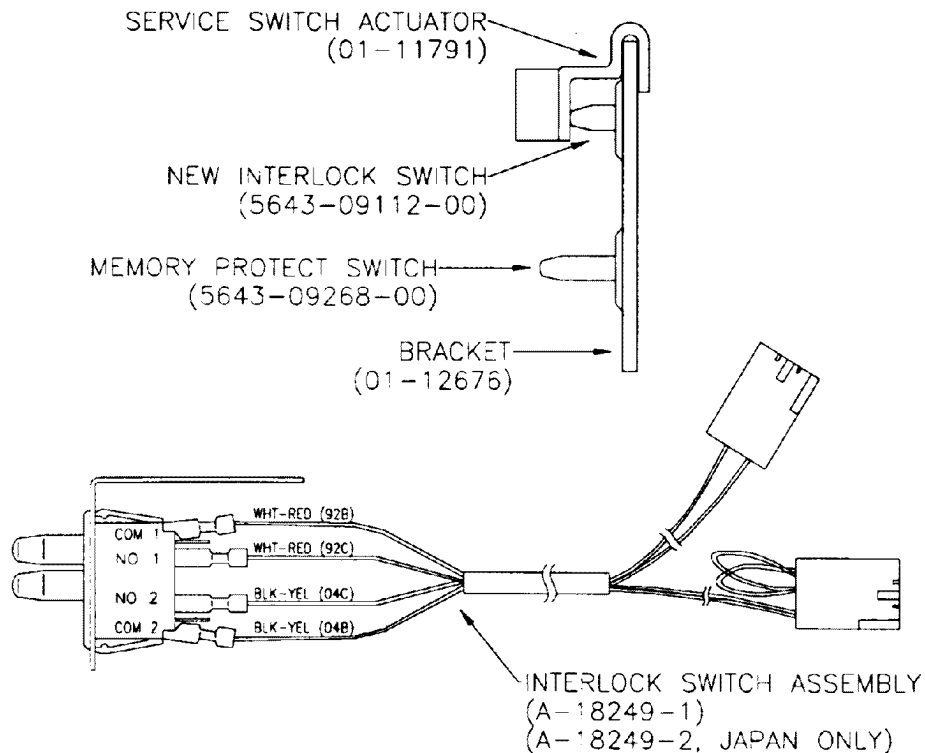

# SCARED STIFF™

Information current at time of release.

Fill out and mail in game registration card. Be sure to include the game serial number. For your records, write the game serial number in the manual.

PIC Number \_\_\_\_\_ Serial Number \_\_\_\_\_

Midway Manufacturing Company reserves the rights to make modifications and improvements to its products.

The specifications and parts identified in this manual are subject to change without notice.

# TABLE OF CONTENTS

<b>Game Rules</b> .....	<b>A-B</b>
<b>Section 1 - Game Operation &amp; Test Information</b> .....	<b>1-1</b>
(System WPC) ROM Summary .....	1-1
Pinball Game Assembly Instructions .....	1-2
Raising the Playfield .....	1-5
Game Control Locations .....	1-6
Game Operation .....	1-7
Menu System Operation and Main Menu .....	1-8
<b>Bookkeeping Menu</b> .....	<b>1-9</b>
B.1 Main Audits .....	1-9
B.2 Earnings Audits .....	1-9
B.3 Standard Audits .....	1-9
B.4 Feature Audits .....	1-10
B.5 Histograms .....	1-12
B.6 Time-Stamps .....	1-12
<b>Printouts Menu</b> .....	<b>1-13</b>
<b>Test Menu</b> .....	<b>1-14</b>
T.1 Switch Edges Test .....	1-14
T.2 Switch Levels Test .....	1-14
T.3 Single Switch Test .....	1-14
T.4 Solenoid Test .....	1-15
T.5 Flasher Test .....	1-15
T.6 G.I. Tests .....	1-15
T.7 Sound and Music Test .....	1-16
T.8 Single Lamp Test .....	1-16
T.9 All Lamps Test .....	1-16
T.10 Lamp and Flasher Test .....	1-16
T.11 Display Test .....	1-16
T.12 Flipper Coil Test .....	1-17
T.13 Ordered Lamp Test .....	1-17
T.14 Lamp Row-Col Test .....	1-17
T.15 Dip Switch Test .....	1-17
T.16 Wheel Test .....	1-17
T.17 Coffin Test .....	1-18
T.18 Crate Test .....	1-18
T.17 Empty Balls Test .....	1-18
<b>Utilities Menu</b> .....	<b>1-19</b>
U.1 Clear Audits .....	1-19
U.2 Clear Coins .....	1-19
U.3 Reset H.S.T.D. .....	1-19
U.4 Set Time & Date .....	1-19
U.5 Custom Message .....	1-19
U.6 Set Game I.D. .....	1-19
U.7 Factory Adjustment .....	1-19
U.8 Factory Reset .....	1-20
U.9 Presets .....	1-20
Game Difficulty Table for U.S./Canada/France .....	1-20
Game Difficulty Table for Germany/Europe .....	1-20
Preset Adjustments Table .....	1-21
U.10 Clear Credits .....	1-23

U.11 Auto Burn-In .....	1-23
<b>Adjustment Menu</b> .....	<b>1-24</b>
A.1 Standard Adjustments .....	1-24
A.2 Feature Adjustments .....	1-28
A.3 Pricing Adjustments .....	1-35
Pricing Table .....	1-43
A.4 H.S.T.D. Adjustments .....	1-44
A.5 Printer Adjustments .....	1-46
Error Messages .....	1-47
CPU Board, Sound Board Error Codes .....	1-48
Opto Theory .....	1-49
LED List .....	1-50
Fuse List .....	1-51
Maintenance Information .....	1-53
Notes .....	1-54

<b>Section 2 - Game Parts Information</b> .....	<b>2-1</b>
Backbox Assembly .....	2-2
Insert Panel Assembly .....	2-2
Cabinet Assembly .....	2-3
WPC '95 Audio Visual Board Assembly .....	2-4
WPC '95 Power Driver Board Assembly .....	2-6
WPC '95 CPU Board Assembly .....	2-8
WPC '95 CPU Board Assembly .....	2-10
Coin Door Interface Board Assembly .....	2-12
Flipper Opto P.C.B. Assembly .....	2-12
Trough IRED LED P.C.B. Assembly .....	2-13
Trough IRED TSTR P.C.B. Assembly .....	2-13
Crate LEDS P.C.B. Assembly .....	2-13
16 Opto P.C.B. Assembly w/brackets .....	2-14
16-LED Skull Driver P.C.B. Assembly .....	2-15
Generic Eddy Sensor P.C.B. Assembly .....	2-16
Stepper Motor Sub-Assembly .....	2-17
Flipper Assembly .....	2-18
Boogie Man Kicker Assembly .....	2-20
Kicker Arm (Slingshot) Assembly .....	2-21
Ball Trough Assembly .....	2-22
Shooter Lane Kicker Assembly .....	2-23
Jet Bumper Assembly .....	2-24
Jet Bumper Coil Assembly .....	2-25
Popper Assembly-Coffin Feed .....	2-26
Popper Assembly-Coffin Feed .....	2-27
Popper Assembly (Left) .....	2-28
Popper Assembly-Jet Exit .....	2-29
Diverter Drive Assembly (Left) .....	2-30
Crate Assembly .....	2-31
Power Interface Assembly .....	2-32
Power Interface/Cordset Application .....	2-33
Back Panel Assembly .....	2-34
Ball Gate Actuator Assembly .....	2-35
Tilt Mechanism Assembly .....	2-36
Knocker Assembly .....	2-36
Ramps .....	2-37



Upper Playfield Parts .....	2-38
Lower Playfield Parts .....	2-40
Rubber Rings .....	2-41
Lamp Matrix/Locations .....	2-42
Switch Matrix/Locations .....	2-44
Solenoid Matrix/Locations .....	2-46
Notes .....	2-48

<b>Section 3 - Wiring Diagrams and Schematics .....</b>	<b>3-1</b>
Connector & Component Identification .....	3-1
Switch Matrix .....	3-2
Switch Circuit Drawings .....	3-2
Lamp Matrix .....	3-4
Lamp Circuit Drawing .....	3-4
Solenoid/Flasher Table .....	3-5
Solenoid Wiring .....	3-6
Flasher Wiring .....	3-7
Solenoid/Flasher Circuit Drawings .....	3-8
Flipper Circuit Drawings .....	3-11
LED & Photo Transistor P.C.B. Assemblies .....	3-14
Flipper Opto Board .....	3-15
Trough IRED LED P.C.B. Assembly .....	3-16
Trough IRED Transistor P.C.B. Assembly .....	3-17
16 Opto P.C.B. ....	3-18
Eddy Sensor P.C.B. ....	3-20
Power Driver P.C.B. Interboard Wiring .....	3-21
Security CPU P.C.B. Interboard Wiring .....	3-25
Audio Visual P.C.B. Interboard Wiring .....	3-27
Coin Door Interface P.C.B. Interboard Wiring .....	3-28
Coin Door Interface P.C.B. Schematic .....	3-29
Notes .....	3-30

*Bally's*

# **SCARED STIFF™**

**Game Rules**

**Complete all 6 TALES OF TERROR for a chance to get...  
SCARED STIFF™**

***TERROR FROM THE CRATE:***

Knock on the Crate for chilling 2-Ball Multi-ball!

***THE MONSTER'S LAB:***

Visit the Jets for electrifying action!

***EYES of the BONY BEAST:***

Shoot the left ramp to complete the Hypnotic Stare!

***THE STIFF in the COFFIN:***

Lock 3 balls to unleash Monstrous Multi-ball!

***NIGHT of the LEAPERS:***

Complete all 3 leaping Frog Targets then Watch Where You Step!

***RETURN of the DEADHEADS:***

Shoot for the Skull Lanes to Wake the Deadheads!

**Explore the SPIDER'S WEB to Enhance Features, LIGHT EXTRA BALL, and Start Special Modes!**

**Get all 6 TALES OF TERROR to activate the STIFF-O-METER and shoot Lit Jackpots to see How Scared Stiff YOU Can Get!!!**

# SECTION ONE

## GAME OPERATION AND TEST INFORMATION

### (System WPC) ROM Summary

IC	TYPE	BOARD	LOCATION	PART NUMBER
Game 1	27c040	CPU	G11	A-5343-50048-1
Security Chip	PIC16C57	CPU	G10	A-5400-50048-1
Music/Speech	27c080	Audio	SU2	A-5343-50048-S2
Music/Speech	27c080	Audio	SU3	A-5343-50048-S3
Music/Speech	27c080	Audio	SU4	A-5343-50048-S4

### NOTICE

Order replacement ROM's from your authorized MIDWAY MANUFACTURING CO. Distributor. Specify:  
(1) Part Number (if available); (2) ROM Level (number on the label); (3) Game in which ROM is used.

# PINBALL GAME ASSEMBLY INSTRUCTIONS

## SCARED STIFF IS A 4 BALL GAME.

**Power:** Domestic 120V @ 60 Hz  
Foreign 230V @ 50 Hz  
Japan 100V @ 50 Hz

**Temp:** 32° F to 100° F  
(0° C to 38° C)

**Humidity:** Not to exceed 95% relative.

**Dimensions:** Width: 40" Approx.  
Depth: 48" Approx.  
Height: 77" Approx.

**Weight:** Approx. 325 Lbs. (crated)

1. Remove all cartons, parts, and miscellaneous items from the shipping container and set them aside.
2. Leg levelers and leg bolts are provided among the parts in the cash box. Install leg levelers on front and back legs (View 1). Place the cabinet on a support and attach rear legs using leg bolts (View 2).
3. Attach front legs using leg bolts (View 2).

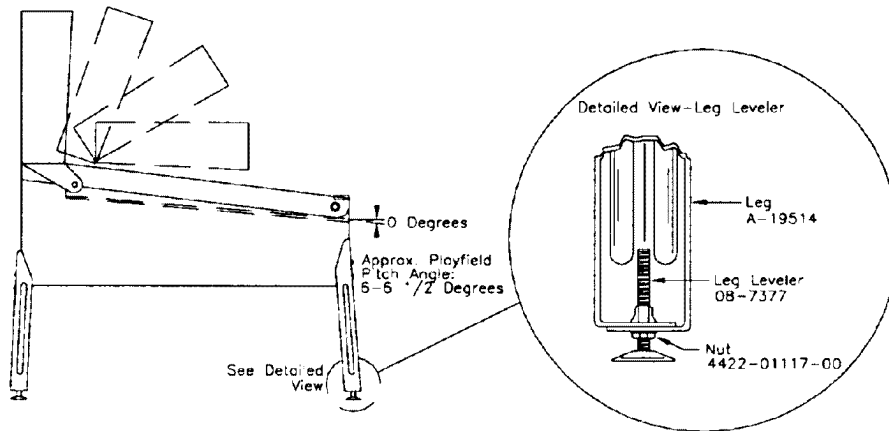

VIEW 1

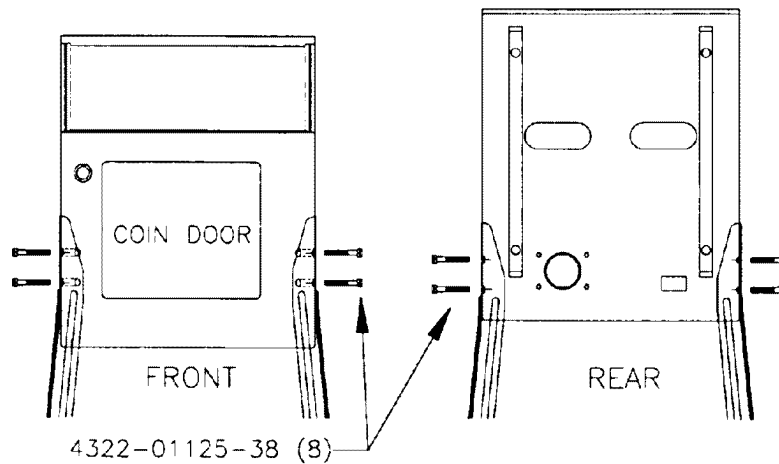

VIEW 2

4. Reach into the cabinet and backbox and ensure that the interconnecting cables are not kinked or pinched. Be careful to avoid damaging wires at any stage of the assembly process.
5. Raise the hinged backbox upright and latch it into position. Unlock the backbox and remove the backglass, storing it carefully to avoid damage. Remove the shipping screws holding the insert panel. Unlatch and open the insert panel. Carefully lift the speaker panel and lay it down on the playfield glass. Be careful not to damage the Dot Matrix Display/Driver Board. This allows access to the bolt holes used for securing the backbox upright. Install the washer-head mounting bolts through the bottom holes of the backbox into the threaded fasteners in the cabinet to secure the backbox. Close the insert panel and latch it into position. Replace the speaker panel. Reinstall the backglass and lock the backbox.



### CAUTION

**FAILURE TO INSTALL** the backbox mounting hardware properly can cause personal injury. **NEVER TRANSPORT** a pinball game with the hinged backbox erect. Always lower the backbox forward onto the playfield cabinet on a layer of protective material to prevent marring or damage and possible personal injury.

6. Extend each leg leveler slightly below the leg bottom, so that all four foot pads protrude approximately the same distance. Remove the cabinet from its support and place it on the floor.
7. Unlock and open the coin door. Move the front molding latch lever toward the left side of the game, to release the front molding. Lift the front molding off the playfield cover glass, return the latch lever to the right, and close the coin door. Carefully slide the glass downward, until it clears the grooves of the left and right side moldings. Lift the glass up and away from the game, storing it carefully to avoid breakage.
8. Place a level or an inclinometer on the playfield surface. Adjust the leg levelers for proper playfield level (side-to-side). NOTE: These measurements must be made ON the playfield, not the cabinet nor the playfield cover glass. Tighten the nut on each leg leveler shaft to maintain this setting.
9. The TRU-PITCH™ level is located on the right shooter rail. This allows the playfield pitch angle to be accurately adjusted WITHOUT REMOVING THE GLASS. The first line (closest to the front of the game) on the level is approximately 6 degrees. Every line thereafter is approximately another 1/2 degree of pitch. The recommended pitch is 6 1/2 degrees. The nose of the bubble should be between the first and second line on the level (see diagram below).

TRU-PITCH™ level 6 1/2 degrees.  
A-15802-P

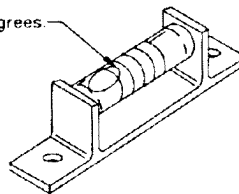

### CAUTION

*Playfield pitch angle adjustments can affect the operation of the plumb bob tilt, inside the cabinet. The plumb bob weight is among the parts in the cash box; the operator should install the weight and adjust this tilt mechanism for proper operation, after completion of the desired playfield pitch angle setting. The unit is factory installed for a 6 1/2 degree angle. If an adjustment is necessary, loosen screw at the bottom of the unit. Move the pointer, one groove at a time to the left or right, depending on the degree desired. Hold pointer in place and tighten screw.*

10. Verify that the **required number** of balls are installed in the game. This game uses 4 balls.
11. Install playfield mylars if desired.

**NOTE:** The **Scared Stiff™** playfield is coated with a special hardcoat surface and does not require a protective mylar. However, mylars can be purchased through your local Bally Distributor. Specify part number 03-9600-1 for the full playfield mylar.

12. Clean and reinstall the playfield cover glass.
13. To attach line cord, remove envelope stapled to the inside cabinet (near cashbox). Remove the four Phillips-head screws that mount the line cord cover plate to the rear cabinet. Match the prongs on the plug with the holes in the receptacle and push line cord securely into place. Make sure cord aligns with the indentation of plate (indentation should point toward bottom of cabinet). Remount line cord cover plate. If desired, tamper resistant screws are provided in an envelope marked "Security Screws" (located in cashbox) to remount cover plate.

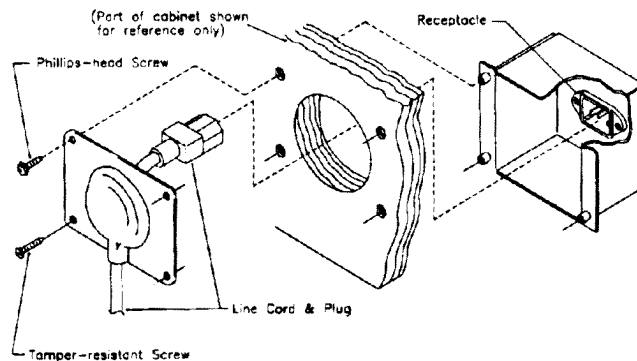

14. Move the game into the desired location; recheck the level and pitch angle of the playfield.
15. If a padlock is desired, install the security bar as shown below.

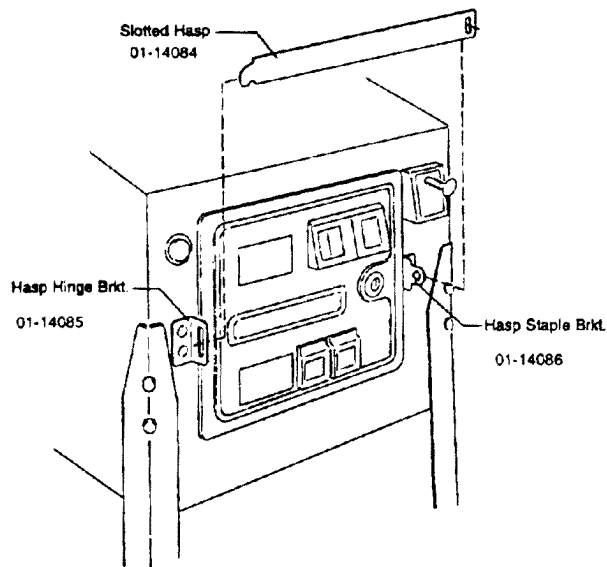

16. **IMPORTANT:** Fill out and return the registration card.

## RAISING THE PLAYFIELD

### CAUTION

Do not raise the playfield straight up! This game uses a slide assembly to raise and lower the playfield.

#### Before Raising the Playfield:

Make sure there are no balls present in the ball trough or any of the other ball-holding playfield devices (i.e. poppers). Raising the playfield with balls present in these locations may cause them to come loose and damage the playfield. Use "Empty Balls Test" to remove all of the balls from these locations.

#### To Raise Playfield:

1. Grasp bottom arch and carefully lift up playfield only high enough to clear safety brackets. Rear guide legs should not hit wood guide rails or be used to slide out playfield.

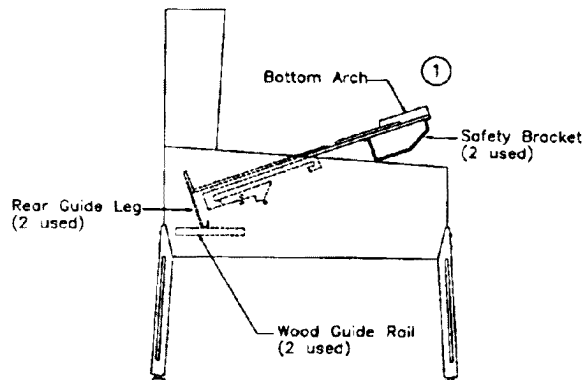

2. Pull the playfield out toward you until it stops (rest position) and raise it approximately 3".

Be sure playfield is in locked position and does not slide back into the cabinet. If it does, repeat Step 2 before proceeding to Step 3.

3. Rotate playfield to upright service position (lean on backbox) by pulling toward you and up. Listen for the sound of a click; this insures locking and pivoting sequence.

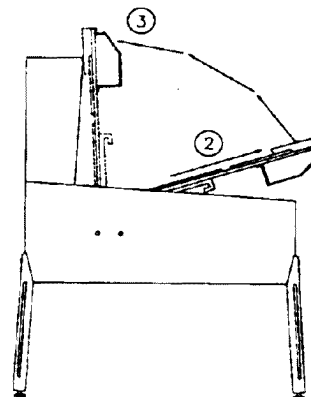

#### To Lower Playfield:

4. Rotate the playfield to the rest position. This unlocks the pivoting sequence.
5. Push back playfield into cabinet and into playing position.

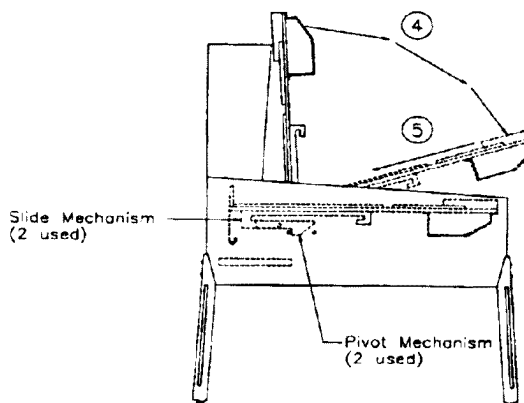



# GAME CONTROL LOCATIONS

## Cabinet Switches

The On-Off switch is located on the bottom of the cabinet near the right front leg.

The Start Button is the push-button to the left of the coin door on the cabinet exterior. Press the Start button to begin a game, or during the diagnostic mode, to ask for HELP.

## Coin Door Switches

The operator controls all game adjustments, obtains bookkeeping information, and diagnoses problems, using only four push-button switches mounted on the inside of the coin door. The Coin Door Switches have two modes of operation: Normal Function and Test Function.

### Normal Function

The Service Credits button puts credits on the game that are not included in any of the game audits.

The Volume Up (+) button raises the sound level of the game. Press and hold the button until the desired level is reached.

The Volume Down (-) button lowers the sound level of the game. Press and hold the button until the desired level is reached. See Adjustment A.1 28 to shut sound OFF completely.

The \*Begin Test button starts the Menu System Operation and changes the Coin Door Switches from Normal Function to Test Function.

### Test Function

The Escape button allows you to get out of a menu selection or return to the Attract Mode.

The Up (+) button allows you to cycle forward through the menu selections or adjustment choices.

The Down (-) button allows you to cycle backward through the menu selections or adjustment choices.

The \*Enter button allows you to get into a menu selection or lock in an adjustment choice.

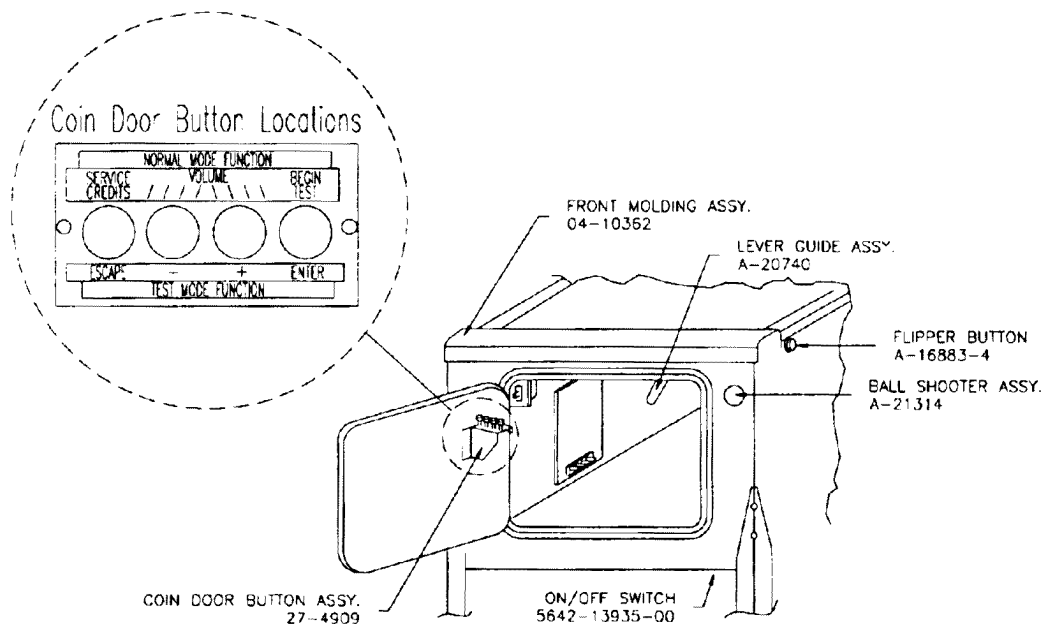

***\*To reset High Score, hold down the Begin Test/Enter switch for 5 seconds while in the Attract Mode.***

# GAME OPERATION

## CAUTION

After assembly and installation at the site location, this game must be plugged into a properly grounded outlet to prevent shock hazard, and to assure proper game operation. DO NOT use a 'cheater' plug to defeat the ground pin on the line cord. DO NOT cut off the ground pin.

**POWERING UP.** With the coin door closed, plug the game in and switch it On. In normal operation, testing will show in the display as the game performs Start-Up Tests. Once the Start-Up Tests have been successfully completed the last score is displayed. After which, the game goes into the Attract Mode.

**Note:** After the game has been on location for a period of time, the Start-Up Tests may contain messages concerning game problems. See 'Error Messages' for more detailed information regarding messages.

Open the coin door and press the Begin Test Switch. The display shows the game name, number, and software revision. The message changes. The display shows the sound software revision, revision level of the system software and date the game software was revised.

**Example: SCARED STIFF**  
50048 Rev. D.01R

**Sound Rev. D.41**  
Sy. 3.57 6/6/96

Press the Enter button to enter the WPC Menu System (refer to the section entitled 'Menu System Operation' for more information). Slide the Service Switch Actuator over the top interlock switch located in the bottom left corner of the coin door opening. Perform the entire Test Menu routine to verify the game is operating satisfactorily.

**ATTRACT MODE\*.** After completing the Test Menu routine, press the Escape button three times to enter the Attract Mode. During the Attract Mode the display shows a series of messages informing the player of the recent highest scores\*, "custom messages\*" and the score to achieve to obtain a replay award\*.

**CREDIT POSTING.** Insert coin(s). A sound is heard for each coin and the display shows the number of credits purchased. So long as the number of maximum allowable credits\* are NOT exceeded by coin purchase or high score, credits are posted correctly.

**STARTING A GAME.** Press the Start button once. A startup sound plays and the credit amount shown in the display decreases by one. The display flashes 00 (until the first playfield switch is actuated), and shows ball 1. If credits are posted, additional players may enter the game by pressing the Start button once for each player, before the end of play on the first ball.

**TILTS.** Actuating the cabinet tilt switch inside the cabinet ends the current game and proceeds to the Game Over Mode. With the third closure\* of the plumb bob tilt switch, the player loses the remaining play of that ball, but can complete the game.

**END OF GAME.** All earned scores and bonuses are awarded. If a player's final score exceeds the specified value, the player receives a designated award for achieving the current highest score. A random digit set\* appears in the display. Credit\* may be awarded when the last two digits of any player's score match the random digits. Match, high score, and game over sounds are made, as appropriate.

**GAME OVER MODE.** Game Over will show in the display. Afterward, the high scores flash on the display. The game proceeds to the Attract Mode.

\*Operator-adjustable feature.

## MENU SYSTEM OPERATION

The Main Menu allows you to choose from several categories, which in turn lead to other menus. To access the Main Menu, open the coin door and press the Begin Test button, then press the Enter button. Press the Up or Down buttons to cycle through the Main Menu. Press the Enter button to access a menu. Press the Escape button to return to the Main Menu. Press the Start button for HELP at any time.

### Main Menu

#### B. Bookkeeping Menu

B.1 Main Audits
B.2 Earnings Audits
B.3 Standard Audits
B.4 Feature Audits
B.5 Histograms
B.6 Time-Stamps

#### P. Printouts Menu

P.1 Earnings Data
P.2 Main Audits
P.3 Standard Audits
P.4 Feature Audits
P.5 Score Histograms
P.6 Game Time Histograms
P.7 Time-Stamps
P.8 All Data

#### T. Test Menu

T.1 Switch Edges
T.2 Switch Levels
T.3 Single Switches
T.4 Solenoid Test
T.5 Flasher Test
T.6 General Illumination
T.7 Sound & Music Test
T.8 Single Lamps
T.9 All Lamps
T.10 Lamp & Flasher Test
T.11 Display Test
T.12 Flipper Test
T.13 Ordered Lamp Test
T.14 Lamp Row-Col Test
T.15 Dip Switch Test
T.16 Wheel Test
T.17 Coffin Test
T.18 Crate Test
T.19 Empty Balls Test

#### U. Utilities Menu

U.1 Clear Audits
U.2 Clear Coins
U.3 Reset H.S.T.D.
U.4 Set Time & Date
U.5 Custom Message
U.6 Set Game I.D.
U.7 Factory Adjustments
U.8 Factory Resets
U.9 Presets
U.10 Clear Credits
U.11 Auto Burn-In

#### A. Adjustments Menu

A.1 Standard Adjustments
A.2 Feature Adjustments
A.3 Pricing Adjustments
A.4 H.S.T.D. Adjustments
A.5 Printer Adjustments

#### Press Escape

To move out of a menu selection.

#### Press Enter

To get into a menu selection.

#### Press Up

Increases sequence; Example A.1, A.2, A.3, A.4.

#### Press Down

Decreases Sequence; Example A.4, A.3, A.2, A.1.

Use Up and Down to cycle through the selections in a menu.

Use Escape and Enter to move into and out of the selected menu

Press the Up or Down buttons to cycle through the menu. Press the Enter button to access an audit menu. Press the Escape button to return to the Bookkeeping Menu.

## B. BOOKKEEPING MENU

### B.1 Main Audits

### B.2 Earning Audits

### B.3 Standard Audits

### B.4 Feature Audits

### B.5 Histograms

### B.6 Time-Stamps

**One Button Audit System.** The Bookkeeping Menu is obtainable directly from the Attract Mode. Repeatedly pressing the Enter button, while in the Attract Mode, will cycle through all of the game audits.

### B.1 Main Audits

B.1 01	Total Earnings	00	B.1 06	Total Plays	00
B.1 02	Recent Earnings	00	B.1 07	Replay Awards	00
B.1 03	Free Play Percent	00	B.1 08	Percent Replays	00
B.1 04	Average Ball Time	00	B.1 09	Extra Balls	00
B.1 05	Time Per Credit	00	B.1 10	Percent Extra Ball	00

### B.2 Earning Audits\*

B.2 01	Recent Earnings	00	B.2 08	Total Earnings*	00
B.2 02	Recent Left Slot	00	B.2 09	Total Left Slot*	00
B.2 03	Recent Center Slot	00	B.2 10	Total Center Slot*	00
B.2 04	Recent Right Slot	00	B.2 11	Total Right Slot*	00
B.2 05	Recent 4th Slot	00	B.2 12	Total 4th Slot*	00
B.2 06	Recent Paid Credits	00	B.2 13	Total Paid Credits*	00
B.2 07	Recent Service Credits	00	B.2 14	Total Service Credits*	00

\*These audits are NOT resettable. They are a record of the earnings of the game since the "CLOCK 1ST SET" Time-Stamp.

### B.3 Standard Audits

B.3 01	Games Started	00	B.3 18	Right Drains	00
B.3 02	Total Plays**	00	B.3 19	Average Ball Time	00
B.3 03	Total Free Play	00	B.3 20	Time Per Credit	00
B.3 04	Free Play Percent	00	B.3 21	Play Time	00:00:00
B.3 05	Replay Awards	00	B.3 22	Minutes On	00
B.3 06	Percent Replays	00	B.3 23	Balls Played	00
B.3 07	Special Awards	00	B.3 24	Tilts	00
B.3 08	Percent Special	00	B.3 25	Replay 1 Awards	00
B.3 09	Match Awards	00	B.3 26	Replay 2 Awards	00
B.3 10	Percent Match	00	B.3 27	Replay 3 Awards	00
B.3 11	H.S.T.D. Credits	00	B.3 28	Replay 4 Awards	00
B.3 12	Percent H.S.T.D	00	B.3 29	1 Player Games	00
B.3 13	Extra Balls	00	B.3 30	2 Player Games	00
B.3 14	Percent Extra Ball	00	B.3 31	3 Player Games	00
B.3 15	Tickets Awarded	00	B.3 32	4 Player Games	00
B.3 16	Percent Tickets	00	B.3 33	H.S.T.D. Reset Count	00
B.3 17	Left Drains	00	B.3 34	Burn-in Time †	00:00:00
B.3 18	Right Drains	00	B.3 35	1st Replay Level	00
B.3 19	Average Ball Time	00	B.3 36	Left Flipper	00
			B.3 37	Right Flipper	00

\*\* "Total Plays" only counts completed games. A game is considered complete when the final ball begins. Audit information from incomplete games is ignored, therefore test and servicing operations do not affect the Audits.

† This Audit is not resettable.

## **B.4 Feature Audits**

- B.4 01 This is the average time per credit.
- B.4 02 Number of ball saves.
- B.4 03 Number of total multi-balls.
- B.4 04 Number of coffin multi-balls played.
- B.4 05 Number of coffin multi-ball jackpots awarded.
- B.4 06 Number of crate multi-balls played.
- B.4 07 Number of games with 2 crate multi-balls.
- B.4 08 Number of games with 3 crate multi-balls.
- B.4 09 Number of crate multiball jackpots.
- B.4 10 Number of games in which multiball was NOT played.
- B.4 11 Number of Spider Game plays.
- B.4 12 Number of Spider Wheel time outs (Player did not choose any item).
- B.4 13 Number of Spider Web extra ball awards.
- B.4 14 Number of Right ramp extra balls lit.
- B.4 15 Number of Extra balls awarded from bonus multiplier.
- B.4 16 Number of Times Saved by the spell lamp has been lit.
- B.4 17 Number of Times Player was saved by the spell.
- B.4 18 Number of Times Player chose Skull item from spider wheel.
- B.4 19 Number of Times Player chose Jackpot item from spider wheel.
- B.4 20 Number of Times Player chose Double Trouble item from spider wheel.
- B.4 21 Number of Times Player chose an Eyeball item from spider wheel.
- B.4 22 Number of Times Player chose Beat the Crate item from spider wheel.
- B.4 23 Number of Times Player chose Coffin item from spider wheel.
- B.4 24 Number of Times Player chose Telepathic item from spider wheel.
- B.4 25 Number of Times Player chose Lab item from spider wheel.
- B.4 26 Number of Times Player chose Boogie Man item from spider wheel.
- B.4 27 Number of Times Player chose Crate item from spider wheel.
- B.4 28 Number of Times Player chose Leaper item from spider wheel.
- B.4 29 Number of Times Player chose Beast item from spider wheel.
- B.4 30 Crate Tale of terror completed.
- B.4 31 Lab Tale of terror completed.
- B.4 32 Beast Tale of terror completed.
- B.4 33 Coffin Tale of terror completed.
- B.4 34 Leaper Tale of terror completed.
- B.4 35 Deadhead Tale of terror completed.
- B.4 36 All Tales of terror completed.
- B.4 37 Stiff-o-meter mode started.
- B.4 38 Leaper mode started.
- B.4 39 Leaper mode completed.
- B.4 40 Leaper extra ball awarded.
- B.4 41 Boogie man mode started.
- B.4 42 Beat the crate mode started.
- B.4 43 Left Ramp made.
- B.4 44 Right Ramp made.
- B.4 45 Stiff-o-meter jackpots.
- B.4 46 Main Skill Shots.
- B.4 47 Spider Skill Shots.
- B.4 48 Left loop shots.
- B.4 49 Left loop to skulls ( Shot to skull lanes ).
- B.4 50 Telepathic standup hit.
- B.4 51 Total Telepathic Power awards.

- B.4 52 Number of Telepathic Power Extra ball awards.
- B.4 53 Number of Telepathic Power Special Awards.
- B.4 54 Number of Telepathic Power Lock Lit awards.
- B.4 55 Number of Telepathic Power "Spot Skull" Awards.
- B.4 56 Number of Telepathic Power Boogie man Boogie awards.
- B.4 57 Number of Telepathic Power Bonus Multiplier awards.
- B.4 58 Number of Telepathic Power 250K awards.
- B.4 59 Number of Telepathic Power 500K awards.
- B.4 60 Number of games with No Tales of terror completed.
- B.4 61 Number of games with 1 Tale of terror completed.
- B.4 62 Number of games with 2 Tales of terror completed.
- B.4 63 Number of games with 3 Tales of terror completed.
- B.4 64 Number of games with 4 Tales of terror completed.
- B.4 65 Number of games with 5 Tales of terror completed.
- B.4 66 Number of games with 6 Tales of terror completed.
- B.4 67 This is the number of times coffin multiball was extended.
- B.4 68 This is the number of times crate multiball was extended.
- B.4 69 Spider popper enter.
- B.4 70 Number of games in which the spider web was completed.
- B.4 71 Left Leaper standup hits.
- B.4 72 Center Leaper standup hits.
- B.4 73 Right Leaper standup hits.
- B.4 74 Number of games that used Buy-in.
- B.4 75 Games with 1 BUY-IN's.
- B.4 76 Games with 2 BUY-IN's.
- B.4 77 Games with 3 BUY-IN's.
- B.4 78 Games with 4 or more BUY-IN's.

## **B.5 Histograms**

B.5	01	1 - 4 Million Score	00%
B.5	02	5 - 9 Million Score	00%
B.5	03	10 - 19 Million Score	00%
B.5	04	20 - 29 Million Score	00%
B.5	05	30 - 39 Million Scores	00%
B.5	06	40 - 49 Million Score	00%
B.5	07	50 - 69 Million Score	00%
B.5	08	70 - 99 Million Score	00%
B.5	09	100 - 149 Million Scores	00%
B.5	10	150 - 199 Million Score	00%
B.5	11	200 - 299 Million Score	00%
B.5	12	300 - 499 Million Score	00%
B.5	13	Over 500 Million	00%
B.5	14	Game Time 0.0 - 1.0 Mins	00%
B.5	15	Game Time 1.0 - 1.5 Mins	00%
B.5	16	Game Time 1.5 - 2.0 Mins	00%
B.5	17	Game Time 2.0 - 2.5 Mins	00%
B.5	18	Game Time 2.5 - 3.0 Mins	00%
B.5	19	Game Time 3.0 - 3.5 Mins	00%
B.5	20	Game Time 3.5 - 4.0 Mins	00%
B.5	21	Game Time 4 - 5 Mins	00%
B.5	22	Game Time 5 - 6 Mins	00%
B.5	23	Game Time 6 - 8 Mins	00%
B.5	24	Game Time 8 - 10 Mins	00%
B.5	25	Game Time 10 - 15 Mins	00%
B.5	26	Game Time Over 15 Mins	00%

## **B.6 Time-Stamps**

The Time-Stamps Menu allows you to view dates and times that are important to game software.

B.6	01	Current Time
B.6	02	Totals Cleared
B.6	03	Clock Last Set
B.6	04	Audits Cleared
B.6	05	Coins Cleared
B.6	06	Factory Setting
B.6	07	Last Game Start
B.6	08	Last Replay
B.6	09	Last H.S.T.D. Reset
B.6	10	Champion Reset
B.6	11	Last Printout
B.6	12	Last Service Credit

Press the Up or Down buttons to cycle through the menu. Press the Enter button to access a menu. Press the Escape button to return to the Printouts Menu.

**P. PRINTOUTS MENU**  
(optional board required)

<b>P.1</b>	<b>Earnings Data</b>
<b>P.2</b>	<b>Main Audits</b>
<b>P.3</b>	<b>Standard Audits</b>
<b>P.4</b>	<b>Feature Audits</b>
<b>P.5</b>	<b>Score Histograms</b>
<b>P.6</b>	<b>Time Histograms</b>
<b>P.7</b>	<b>Time-Stamps</b>
<b>P.8</b>	<b>All Data</b>

The Printouts Menu is a combination of the other menus. This menu allows you to access and print information in the available menu selections.

If no printer is attached the message "Waiting for Printer" appears in the displays.

Note: Set print specification from the Adjustment Menu, A.5 Printer Adjustments.



**Use the Service Switch Actuator to hold in the top interlock switch located in the bottom left corner of the coin door opening. The actuator must be in place in order to activate the solenoids and flashlamps.**

Press the Up or Down buttons to cycle through the menu. Press the Enter button to access a test. Press the Escape button to return to the Test Menu.

**Note:** During any test, press the Start button to obtain the wire color, driver number, connector number and fuse location.

### **T. TEST MENU**

<b>T.1</b>	<b>Switch Edges</b>
<b>T.2</b>	<b>Switch Levels</b>
<b>T.3</b>	<b>Single Switch</b>
<b>T.4</b>	<b>Solenoid Test</b>
<b>T.5</b>	<b>Flasher Test</b>
<b>T.6</b>	<b>General Illumination</b>
<b>T.7</b>	<b>Sound &amp; Music Test</b>
<b>T.8</b>	<b>Single Lamps</b>
<b>T.9</b>	<b>All Lamps</b>
<b>T.10</b>	<b>Lamp &amp; Flasher Tests</b>
<b>T.11</b>	<b>Display Test</b>
<b>T.12</b>	<b>Flipper Test</b>
<b>T.13</b>	<b>Ordered Lamps Test</b>
<b>T.14</b>	<b>Lamp Row-Col Test</b>
<b>T.15</b>	<b>Dip Switch Test</b>
<b>T.16</b>	<b>Wheel Test</b>
<b>T.17</b>	<b>Coffin Test</b>
<b>T.18</b>	<b>Crate Test</b>
<b>T.19</b>	<b>Empty Balls Test</b>

The switch matrix, on the left side of the display, shows the state of all switches. A dot indicates the switch is open, and a square indicates the switch is closed. The numbers assigned to each switch indicate where the switch is located in the matrix. The number on the left indicates the column, and the number on the right indicates the row. Example: Switch 23 is 2nd column, 3rd row.

A short to ground, on either the row or column wire, appears as a shorted row(s). However, a column wire shorted to ground disappears when all the indicated row switches are open. A row wire shorted to ground does not disappear.

A shorted diode in the switch matrix can cause other switches to appear closed. These "phantom" switches (though not actually closed) complete a rectangle in the switch matrix. Therefore, if two switches in the same column are closed (example; #22 and #24), and a third switch is pressed in another column but in the same row as one of the first two (example; #32), the "phantom" switch #34 is falsely indicated as closed. The switch with the shorted diode is diagonally opposite the "phantom" switch (in this case #22).

**T.1 Switch Edges** Press each switch one at a time. The name and number of the switch is shown in the display. If a switch other than the one pressed, or no switch at all is indicated, the system has detected a problem with the switch circuit.

**T.2 Switch Levels** This test automatically cycles through all switches that are detected closed. The name and number of each switch that is detected is shown in the display. A filled square indicates the switch's position in the matrix.

**T.3 Single Switches** The Single Switch Test isolates a particular switch by blocking signals from all other switches. Use the Up or Down buttons to select the switch to be tested.

**T.4 Solenoid Test** The Solenoid Test has three modes: Repeat, Stop, and Run. Only one solenoid should pulse at a time. The system has detected a problem if; more then one solenoid pulses, a solenoid comes On and stays On, or no solenoids pulse during the Repeat or Run modes.

- Repeat - The Repeat Mode pulses a single solenoid. After entering this test, Solenoid 1 shows in the display. and the corresponding solenoid activates. Press the Up or Down button to cycle through the solenoids, one at a time. The same solenoid pulses until the Up or Down button is pressed. Either press the Escape button to return to the Test Menu, or press the Enter button to advance to the next mode.
- Stop - The Stop Mode halts the Solenoid Test. Press Enter during the Repeat mode and the Solenoid Test Stops. No solenoids should be activated while the test is stopped. Either press the Escape button to return to the Test Menu, or the Enter button to advance to the next mode.
- Run - The Run Mode cycles through the solenoids automatically. The display shows the name and number of the solenoid currently being pulsed. Either press the Escape button to return to the Test Menu, or the Enter button to advance to the next mode.

**T.5 Flasher Test** This tests the flashlamp part of the solenoid circuit exclusively. This, like the Solenoid Test has three test modes: Repeat, Stop, and Run. During this test, only one flashlamp circuit should pulse at a time. The system has detected a problem if more than one circuit pulses, a circuit stays On, or no circuits pulse during the Repeat or Run modes.

- Repeat - The Repeat mode pulses a single flashlamp. After entering this test, the name and number of the first flashlamp circuit will show in the display and the corresponding bulb(s) flash. Press the Up or Down button to cycle through all of the flashlamp circuits one at a time. The same circuit pulses until the Up or Down button is pressed. Either press the Escape button to return to the Test Menu, or press the Enter button to advance to the next mode.
- Stop - The Stop Mode halts the Flasher Test. No flashlamp circuit should be active during this mode. Either press the Escape button to return to the Test Menu, or the Enter button to advance to the next mode.
- Run - The Run Mode cycles through the flashlamps automatically. The display shows the name and number of the flashlamp circuit currently being pulsed and the corresponding bulb(s) flash. Either press the Escape button to return to the Test Menu, or the Enter button to advance to the next mode.

**T.6 General Illumination** This test checks all of the General Illumination circuits. There are two modes of operation: Stop and Run. **Note: G.I strings 4 and 5 do not dim and brighten, they are always ON.**

- Stop - Press the Up or Down buttons to cycle through the General Illumination Test manually. All illumination is tested first, followed by an individual circuit test. The circuit name and number will show in the display while the corresponding lamps light. If any other results occur the system has detected an error.
- Run - Press the Enter button any time during Stop mode and the General Illumination Test cycles through automatically. For each circuit shown in the displays the corresponding bulbs should light. If any other results occurs the system has detected a problem.

**T.7 Sound and Music Test** The Sound and Music Test allows you to check the audio circuits. This test has three modes for testing the sound and music circuits: Run, Repeat, and Stop.

- Run - The Run Mode steps through a sequence of sounds and music. Pressing the Up or Down button during this portion of the Sound and Music test advances to a particular sound/tune without having to wait for the program to play all the sounds available in the test. A sound/tune should be heard for each name and number that appears in the display. Any other results indicate the system has detected a problem.
- Repeat - Press the Enter button at any time during the Run Mode to cause the program to stop and repeat a particular sound/tune. The same sound should repeat continuously until the Up or Down button is pressed. Any other results indicates the system has detected a problem.
- Stop - Press the Enter button at any time during the Repeat Mode to stop this test altogether. No sound/tune should be heard. Any other results indicates the system has detected a problem.

**T.8 Single Lamp Test** The number assigned to each lamp indicates the lamp's position in the matrix. The number on the left indicates the column. The number on the right indicates the row. Example: Lamp 23 means 2nd column, 3rd row.

This test checks each lamp circuit individually. Press the Up or Down button to cycle through this test. For each name and number that is shown in the display the corresponding lamp should light. Any other results indicate the system has detected a problem.

**T.9 All Lamps Test** This test causes all the controlled lamps to flash at the same time. Every controlled lamp should flash. Any other results indicate the system has detected a problem.

**T.10 Lamp and Flasher Test** This test causes all the flashlamps and the controlled lamps to flash at the same time. The controlled lamps blink, while the flashlamps cycle from highest to lowest. Any other results indicates the system has detected a problem.

**T.11 Display Test** This test automatically lights every dot in the Dot Matrix Display. A series of patterns appear in sequence. Each pattern turns On and Off a section of dots. Every dot on the display should be turned On and Off during this test.

**T.12 Flipper Coil Test** The Flipper Coil Test has three modes: Repeat, Stop, and Run. Only one flipper should pulse at a time. The system has detected a problem if more than one flipper pulses, a flipper comes On and stays On, or no flippers pulse during the Repeat or Run modes.

- Repeat - The Repeat Mode pulses a single flipper. After entering this test, coil 01 shows in the display and the corresponding flipper activates. Press the Up or Down button to cycle through the flipper coils, one at a time. The same flipper coil pulses until the Up or Down button is pressed. Either press the Escape button to return to the Test Menu, or press the Enter button to advance to the next mode.
- Stop - The Stop Mode halts the Flipper Coil Test. Press Enter during the Repeat mode and the Flipper Coil Test stops. No flipper coil should be activated while the test is stopped. Either press the Escape button to return to the Test Menu, or the Enter button to advance to the next mode.
- Run - The Run Mode cycles through the flippers automatically. The display shows the name and number of the flipper coil currently being pulsed. Either press the Escape button to return to the Test Menu, or the Enter button to advance to the next mode.

**T.13 Ordered Lamp Test** The number assigned to each lamp indicates the lamp's position in the matrix. The number on the left indicates the column. The number on the right indicates the row. Example - Lamp 23 means 2nd column, 3rd row.

This test checks each lamp circuit individually. Press the Up or Down button to cycle through the lamps. Lamps light in a clock-wise or counter clock-wise direction starting from the bottom of the playfield. Direction depends on which button, Up or Down, is pressed. For each name and number that is shown in the display the corresponding lamp should light. Any other results indicates the system has detected a problem.

**T.14 Lamp Row-Col Test** This test allows individual rows and columns in the lamp matrix to be operated. This is useful for trouble-shooting wiring and driver problems.

Press the UP or DOWN buttons to cycle trough the different rows and columns.

**T.15 Dip Switch Test** This test is used to show the positions of the dip switches on the CPU board (U27).

**T.16 Wheel Test** Advance to test T.16 and press the Enter Button.

The Spider wheel will initialize while displaying the status of the Wheel Index Opto and the current wheel position. The wheel will then stop. Pressing enter will cause the wheel to free spin, while displaying the index opto status and current wheel position. Pressing enter again will stop the wheel. While the wheel is stopped, pressing "+" will advance the wheel one step at a time.

**T.17 Coffin Test** Advance to test T.17 and press the Enter Button.

The coffin diverter will open and the display will show the status of each of the coffin lockup switches. If a ball is placed in the coffin diverter entrance the operator can verify the correct function of each of the coffin device opto's. The coffin lid will then open and the ball will be ejected from the coffin. (After 30 seconds with no activity, the coffin test will automatically close the diverter and exit. )

**T.18 Crate Test** - Advance to test T.18 and press the Enter Button.

The crate test display will appear, showing the status of the crate switches. Passing a ball over the sensor in front of the crate will cause the crate to unlock for approximately 5 seconds. A ball can then be thrown into the crate to verify the correct function of the crate entrance opto. The ball will be ejected from the crate and the crate will lock.

**T.19 Empty Balls Test** This test kicks out all balls loaded in troughs, lockups, poppers, and kickouts until no balls remain in those locations.

Note: As the trough kicks out balls, they will stack up in the shooter groove, which may require manual clearing in order to allow further balls to be kicked out.

Press the Up or Down buttons to cycle through the menu. Press the Enter button to access a utility. Press the Up or Down buttons to see the setting choices. Press the Enter button to lock in a choice. If a mistake is made, press Escape while "Saving Adjustment Value" is in the display. The original settings is retained and the new settings is ignored. Press the Escape button to return to the Utility Menu.

## **U. UTILITIES MENU**

**U.1 Clear Audits**

**U.2 Clear Coins**

**U.3 Reset H.S.T.D.**

**U.4 Set Time & Date**

**U.5 Custom Message**

**U.6 Set Game I.D.**

**U.7 Factory Adjustments**

**U.8 Factory Resets**

**U.9 Presets**

**U.10 Clear Credits**

**U.11 Auto Burn-In**

**U.1 Clear Audits** Press the Enter button to clear the Standard Audits (except Burn-In Time), Feature Audits, and Histograms.

**U.2 Clear Coins** Press the Enter button to clear the Earnings Audits.

**U.3 Reset H.S.T.D.** Press the Enter button to clear the High Score to Date Table and the Grand Champion.

**U.4 Set Time and Date** Press the Enter button to activate the time and date. Use the Up or Down button to change the value, then press the Enter button to lock in that value. If a mistake is made, press the Escape button while "Saving New Date And Time" is displayed. The new value is ignored and the original value is retained.

**U.5 Custom Message** Set A.1 20 to ON before writing a Custom Message. Press the Enter button to begin entry of the custom message. Use the Up or Down button to cycle through letters. Use the Start button to cycle through punctuation marks. Press the Enter button to lock in the desired letter and punctuation. If you make a mistake, use Up and Down to select the "back-arrow" character. The "back-arrow" character is located before the space character and after the number nine. Press Enter while the back-arrow shows to erase the previously entered character. Once your message is complete, press and hold the Enter button until "Message Stored" is displayed.

Press the Escape button to cancel the new message. The message "Press Enter to Reset" appears. If you press Enter, the custom message is cleared and no message is displayed. If Escape is pressed, the original message remains intact.

**U.6 Set Game I.D.** This utility allows the operator to install a message, such as game location, that only appears on printouts . Press the Enter button to activate Set Game I.D.. Use the Up or Down button to cycle through letters. Use the Start button to cycle through punctuation marks. Press the Enter button to lock in the desired letter and punctuation.

**U.7 Factory Adjustment** Press the Enter button to restore the adjustments to factory settings.

**U.8 Factory Reset** Press the Enter button to restore the adjustments to their factory setting, clear the Audits, H.S.T.D Table, and Custom Message/Game I.D.

**U.9 Presets** Use the Up or Down buttons to cycle through the available Presets. When the desired Preset is displayed, press the Enter button to lock in that Preset. If a mistake is made, press the Escape button while "Executing..." is displayed. The new value is ignored and the original value is retained.

**Game Difficulty Levels** The game play difficulty adjustments can be changed to a combination that is MUCH LESS to MUCH MORE difficult than Factory Settings. The Game Difficulty Setting Table lists the adjustments and settings that comprise the individual groups.

**U.9 01 Install Extra Easy** MUCH LESS difficult than factory setting.

**U.9 02 Install Easy** Somewhat LESS difficult than factory setting.

**U.9 03 Install Medium** About the SAME as factory setting.

**U.9 04 Install Hard** Somewhat MORE difficult than factory setting.

**U.9 05 Install Extra Hard** MUCH MORE difficult than factory setting.

**Game Difficulty Setting Table for U.S./Canadian/French/German/European Games**

Adj. No.	Adjustment Description	Extra Easy U.9 01	Easy U.9 02	Medium U.9 03	Hard U.0 04	Extra Hard U.9 05
A.2 02	BUY-IN COUNT	1	1	1	1	1
A.2 07	BALL SAVES	3	2	1	OFF	OFF
A.2 08	BALL SAVE TIME	8	6	4	OFF	OFF
A.2 09	COFFIN BALL SAVE	10	8	6	4	2
A.2 10	CRATE BALL SAVE	10	8	6	4	2
A.2 11	EXTRA BALL PERCENTAGE	35	30	20	15	5
A.2 12	RAMP EXTRA BALL START	4	6	8	10	12
A.2.13	RAMP EX. BALL 2	ON	ON	ON	OFF	OFF
A.2 14	AUTO-FIRE LOCKS	NO	NO	NO	NO	YES
A.2 15	COFFIN MULTIBALL	EX. EASY	EASY	MEDIUM	HARD	EX. HARD
A.2 16	CRATE MULTIBALL	EX. EASY	EASY	MEDIUM	HARD	EX. HARD
A.2 17	RAMP EXTRA BALL MEMORY	YES	YES	YES	NO	NO
A.2 18	SPIDER EX BALL MEMORY	YES	YES	YES	NO	NO
A.2 19	MYSTERY EX BALL MEMORY	YES	YES	YES	NO	NO
A.2 20	STIFF MODE TIMER	60	40	30	20	15
A.2 21	BOOGIE MODE TIME	40	35	20	15	15
A.2 22	2X MODE TIME	45	30	20	15	15
A.2 23	LEAPER MODE TIME	40	30	20	15	15
A.2 24	BEAT MODE TIMER	40	30	20	15	15

**U.9 06 Install 5 Ball****U.9 07 Install 3 Ball**

Adjustments U.9 06 and U.9 07 can be used to change a game to 3 or 5 ball play, including the changing of certain features to the recommended 3- and 5-ball level. The Preset Game Adjustments Table for U.S./Canadian Games lists the adjustments and settings that comprise the individual groups.

**Preset Game Adjustments Table**

Adjustment Number	Adjustment Description	Install 3-Ball U.9 07 (factory)	Install 5 Ball U.9 06
A.2 02	BUY-IN COUNT	1	1
A.2 07	BALL SAVES	1	1
A.2 08	BALL SAVE TIME	4	OFF
A.2 09	COFFIN BALL SAVE	6	4
A.2 10	CRATE BALL SAVE	6	4
A.2 11	EXTRA BALL PERCENTAGE	20	15
A.2 12	RAMP EXTRA BALL START	8	10
A.2.13	RAMP EXTRA BALL 2	ON	OFF
A.2 14	AUTO-FIRE LOCKS	NO	NO
A.2 15	COFFIN MULTI-BALL	MEDIUM	HARD
A.2 16	CRATE MULTI-BALL	MEDIUM	HARD
A.2 17	RAMP EXTRA BALL MEMORY	YES	NO
A.2 18	SPIDER EXTRA BALL MEMORY	YES	NO
A.2 19	MYSTERY EXTRA BALL MEMORY	YES	NO
A.2 20	STIFF MODE TIMER	30	20
A.2 21	BOOGIE MODE TIME	20	15
A.2 22	2X MODE TIME	20	15
A 2 23	LEAPER MODE TIME	20	20
A.2 24	BEAT MODE TIMER	20	15

**U.9 08 Install Add-A-Ball** This option deletes all Free Play awards and replaces them with Extra Ball awards. Individual adjustments are affected, as follows:

<u>Adjustment</u>	<u>Name</u>	<u>New Setting</u>
A.1 13	Replay Boost	Off
A.1 14	Replay Award	Extra Ball
A.1 15	Special Award	Extra Ball
A.1 17	Extra Ball Ticket	No
A.1 19	Match Feature	Off
A.4 04	Champion Credits	00
A.4 05	High Score 1 Credits	00
A.4 06	High Score 2 Credits	00
A.4 08	High Score 3 Credits	00
A.4 07	High Score 4 Credits	00
A.4 20	Alien Champion Credits	00



**U.9 09 Install Ticket** This option deletes Credit awards and replaces them with Ticket awards. Individual adjustments are affected, as follows:

<u>Adjustment</u>	<u>Name</u>	<u>New Setting</u>
A.1 14	Replay Award	Ticket
A.1 15	Special Award	Ticket
A.1 16	Match Award	Ticket
A.1 17	Extra Ball Ticket	Yes
A.1 31	Ticket Expansion Board	Yes
A.4 02	H.S.T.D. Award	Ticket

**U.9 10 Install Novelty** This option removes all Free Play and Extra Ball awards. Individual adjustments are affected, as follows:

<u>Adjustment</u>	<u>Name</u>	<u>New Setting</u>
A.1 04	Max. Extra Ball	Off
A.1 05	Replay System	Fixed
A.1 09	Replay Level 1	Off
A.1 10	Replay Level 2	Off
A.1 11	Replay Level 3	Off
A.1 12	Replay Level 4	Off
A.1 15	Special Award	Points
A.1 19	Match Feature	Off
A.4 01	Highest Score	On
A.4 04	Champion Credits	00
A.4 05	High Score 1 Credits	00
A.4 06	High Score 2 Credits	00
A.4 07	High Score 3 Credits	00
A.4 08	High Score 4 Credits	00
A.4 20	Alien Champion Credits	00

**U.9 11 Not Used**

**U.9 12 Serial Capture** This sets up the printer adjustments for serial transmission to a laptop computer (9600 baud, 40 column, no page breaks, serial printer). This option requires the installation of the optional printer kit, part number 63110.

**U.9 13 thru U.9 16 Not Used**

**U.9 17 Install German 1•**

**U.9 18 Install German 2•**

**U.9 19 Install German 3•**

**U.9 20 Install German 4•**

**U.9 21 Install German 5•**

**U.9 22 Install German 6•** Adjustments U.9 17 through U9 22 are used to modify game pricing and type of game play. The Preset Game Adjustments Table for German/European Games lists the adjustments and settings that comprise the individual groups.

- U.9 23 Install French 1\***
- U.9 24 Install French 2\***
- U.9 25 Install French 3\***
- U.9 26 Install French 4\***
- U.9 27 Install French 5\***
- U.9 28 Install French 6\***

Adjustments U.9 23 through U.9 28 are used to modify game pricing and type of play. The Preset Game Adjustments Table for French Games lists the adjustments and settings that comprise the individual groups.

\* The French DIP Switch Settings are:

<u>SW4</u>	<u>SW5</u>	<u>SW6</u>	<u>SW7</u>	<u>SW8</u>
On	On	On	Off	Off

**U.10 Clear Credits** Press the Enter button to clear the game Credits.

**U.11 Auto Burn-in** Press the Enter button to activate Auto Burn-in. This utility automatically cycles through several tests. This will help in find intermittent problems. The tests that Auto Burn-in cycle through are: the Display Test, Sound and Music Test, All Lamps Test, Solenoid Test, Flashers Test, General Illumination Test, and the Flipper Coil Test. All of the tests are run concurrently. The time spent on the current burn-in cycle, and the total time the game has spent in burn-in are displayed.

Press the Up or Down buttons to cycle through the menu. Press the Enter button to access an adjustment. Press the Up or Down buttons to see the setting choices. Press the Enter button to lock in a choice. If a mistake is made, press Escape while "Saving Adjustment Value" is in the display. The original settings is retained and the new value is ignored. Press the Escape button to return to the Adjustment Menu.

## **A. ADJUSTMENTS MENU**

**A.1 Standard Adjustments**

**A.2 Feature Adjustments**

**A.3 Pricing Adjustments**

**A.4 H.S.T.D Adjustments**

**A.5 Printer Adjustments (optional board required)**

### **A.1 Standard Adjustments**

#### **A.1 01 Balls Per Game**

A "game" is defined by specifying the number of balls to be played.

Range: 1-10

#### **A.1 02 Tilt Warnings**

The number of total actuation's of the plumb bob mechanism that can occur before the game is "tilted".

Range: 1-10

#### **A.1 03 Maximum Extra Balls**

The number of extra balls that a player may accumulate.

Range: 1-10

NO EXTRA BALL: - No Extra Balls may be accumulated.

#### **A.1 04 Maximum Extra Balls/Ball in Play**

The number of extra balls to be awarded per ball in play.

OFF - No maximum number of Extra Balls per ball in play.

1-10 - 1 through 10 Extra Balls per ball in play.

#### **A.1 05 Replay System**

The type of replay system to be used.

Fixed - Replay value is set and does not change during game play.

Auto % - Replay starting value is set and changes every 50 games to comply with the percentage of replays desired.

#### **A.1 06 Replay Percent\***

The percentage of replays the players are able to earn when Auto Replay is used.

Range: 5-50%

#### **A.1 07 Replay Start\***

The replay start value when Auto % Replay is used. The range of this setting is 500,000,000 to 9,500,000,000.

#### **A.1 08 Replay Levels\***

The number of replay levels used by the Auto % Replay mode. The range of this setting is 1 to 4. When two replay levels are chosen, the second replay level is automatically adjusted to twice the starting replay level value. When three of four replay levels are chosen, their values are automatically adjusted to three or four times the starting replay level.

\*For Auto % Replay.

#### **A.1 13 Replay Boost**

The replay score can be temporarily boosted by the selected amount EACH time the player reaches or exceeds the replay score. This temporary boost is canceled when credits equal 0, the player inserts another coin, or Begin Test is pressed.

Range: - Score is boosted between 200,000,000 and 2,500,000,000 points.  
OFF - Replay score is not boosted.  
AUTO - Replay score is boosted by ½ of the base replay score.

#### **A.1 14 Replay Award**

For the form of award automatically provided when the player exceeds any replay level for either Auto % Replay, or Fixed Replay.

Credit - Reaching each Replay level awards credit.  
Ticket - Reaching each Replay level awards a ticket.  
Audit - Reaching each Replay level awards nothing to the player; it does increase the entry value of the Audit Item(s) maintaining a tally of these awards.

#### **A.1 15 Not Used**

#### **A.1 16 Match Award**

The award automatically provided when the player wins a match.

Credit - Winning a Match awards a Credit.  
Token - Winning a Match awards a Token.

#### **A.1 17 Extra Ball Ticket**

A Ticket is awarded when the player earns an Extra Ball.

YES - The player is awarded a Ticket in addition to an Extra Ball.  
NO - The player is not awarded a Ticket.

#### **A.1 18 Maximum Ticket/Player**

The amount of Tickets each player can earn.

Range 00 - 100

#### **A.1 19 Match Feature**

The desired percentage for the Match Feature occurring at the end of the game.

OFF - Match Feature is not available.  
1 -50% - 1% is 'hard'; 50% is 'extremely easy'. The Match Feature selects a random two-digit number at the end of the game and compares each players score for an identical two digits in the rightmost two positions. A matching of these two digits results in an award of a Credit or a Ticket.

**A.1 20 Custom Message**

The message displayed during the Attract Mode.

- YES - A message is displayed
- NO - A message is not displayed.

**A.1 21 Language**

The language the game uses: English, German, French or Spanish.

**A.1 22 Clock Style**

The style of clock the game uses: A.M./P.M., or 24 Hours.

**A.1 23 Date Style**

The style of date the game uses: Month/Date/Year, or Date/Month/Year.

**A.1 24 Show Date and Time**

The date and time show in the Attract Mode.

- YES - Show date and time in status report, or Attract Mode.
- NO - Do Not show date and time in status report or Attract Mode.

**A.1 25 Allow Dim Illumination**

The game program dims the General Illumination for special effects and during the Attract Mode.

- YES - Dim General Illumination for special effects and Attract Mode.
- NO - Do Not dim General Illumination.

**A.1 26 Tournament Play**

Equalize random game features and global score values during multi-player games.

- YES - Equalize random game features and global score values.
- NO - Do Not equalize random game features and global score values.

**A.1 27 Euro. Scr. Format**

Use either commas or dots between digits when numbers are displayed.

- YES - Dots instead of commas, (example 1.000.000).
- NO - Commas instead of dots, (example 1,000,000).

**A.1 28 Minimum Volume Override**

The volume can be turned Off.

- YES - Volume can be turned Off.
- NO - Volume can be turned Down but not Off.

**A.1 29 General Illumination Power Saver**

This allows the general illumination and controlled lamps to be dimmed following a time interval after a game is played. Power Saver Level (A.1 30) determines dimness of the lamps. Using this feature will substantially increase the life of the lamps.

- Setting: - Off, 2-60 Minutes

**A.1 30 Power Saver Level**

When General Illumination Power Saver (A.1 29) is set to On, this controls the intensity of the G.I. and controlled lamps once the game has been idle for a specified period of time.

Range: 4-7 (4 = dimmest, 7 = brightest)

**A.1 31 Ticket Expansion Board**

When a Ticket Expansion Board is connected, full control of the ticket dispenser is available. This includes a ticket low/error lamp, resume on ticket jam switch, and manual ticket dispense switch.

- Yes - Ticket Expansion Board is connected.
- No - Ticket Expansion Board is NOT installed in the game.

**A.1 32 No Bonus Flips**

The activation of flippers during the end of ball "bonus" sequence. Setting this to "YES" may extend the life of the flipper mechanisms.

**A.1 33 Game Restart**

When the start button is pressed during or after the 2nd ball, the game in progress will end and a new game will begin. This adjustment has 3 settings to determine how this is handled.

- Never: - Do not allow a new game to start until the current game is over.
- Slow: - Restart if the start button is pressed continuously for over 1/2 second. This helps to prevent the unintended restart of game in progress.
- Instantly: - Restart as soon as the start button is pressed.

When the start button is pressed during game over, or during the 1st ball (to add a player), it is always handled instantly.

## **A.2 Feature Adjustments**

### **A.2 01 Buy Extra Ball - Buy In Feature**

This determines whether each player may buy 1 extra ball for 1 credit at the end of the game.

Settings :       1 CREDIT  
                  OFF

Factory Default: OFF

### **A.2 02 Buy-In Count**

If A.2 01 (BUY EXTRA BALL) is set to "1 CREDIT". This determines the number of Extra Balls that may be purchased at the end of the game. The choices are 1-3 or Unlimited.

### **A.2 03 Attract Mode Sounds**

The operator can select whether or not the game will play music and speech during the attract mode to attract players. The choices are:

ON = The attract mode does have Sound and Music.

OFF = The attract mode does not have Sound OR Music.

Factory Default: OFF

### **A.2 04 Flipper Sounds**

The operator can select whether or not the attract mode has sound on the flipper and launch buttons to attract players. The choices are:

ON = The attract mode does have sound on buttons

OFF = The attract mode does not have sound on buttons

Factory Default: ON

### **A.2.05 Attract Spider**

The operator chooses if the Spider Device will be activated in the attract mode. The choices are:

YES = The Spider device will be activated from time to time during the attract mode.

NO = The Spider device will NOT be activated during the attract mode.

Factory Default: YES

### **A.2 06 Timed Plunger**

The ball launch plunger automatically shoots for the player after specified amount of time.

Setting: ON = After 30 - 90 Seconds, the plunger will kick automatically.

          OFF = The plunger will NOT kick automatically.

Factory Default: OFF

**A.2 07 Flipper Plunger**

Pressing the flipper button will fire the launch plunger. (Turn this adjustment on ONLY if the Launch button does not function properly.) The choices are:

NO = Pressing the right flipper does not launch the ball.

YES = Pressing the right flipper will launch the ball.

Factory Default: NO

**A.2 08 Ball Saves**

Maximum number of ball saves a player is allowed.

Setting: 1-5 Balls.

Factory Default: 1 Ball

**A.2 09 Ball Save Time**

Sets the amount of time a player has Ball Save active at the start of each ball.

Setting: 3-15 seconds. OFF

Factory Default: 6 Seconds.

**A.2 10 Coffin Ball Save**

Sets the amount of time a player has Ball Save active at the start of Coffin Multiball. (This is the Main Multiball.)

Setting: 2-10 seconds. OFF

Factory Default: 6 Seconds.

**A.2 11 Crate Ball Save**

Sets the amount of time a player has Ball Save active at the start of Crate Multiball. (This is the 2-Ball Multiball.)

Setting: 2-10 seconds. OFF

Factory Default: 6 Seconds.



#### **A.2 12 Extra Ball Percentage**

The operator selects the percentage of Extra Balls desired. The game will try to match this percentage by:

- 1) Increasing or decreasing the number of right ramp shots needed to light extra ball.
- 2) Increasing or decreasing the number of times the Telepathic power award will give extra ball.
- 3) Increasing or decreasing the difficulty of getting extra ball from the spider wheel.

The setting range is OFF-35 percent.

Factory Default: 20 percent.

#### **A.2 13 Ramp Extra Ball Start**

This is the number of Right Ramp shots ( High Speed Laps ) needed to light extra ball. The machine will start at this value, and modify it as needed to achieve the percentage specified in A.2.12

Setting: 4 - 12

Factory Default: 8 Ramp shots.

#### **A.2. 14 Ramp Extra Ball 2**

Determines if a second Extra ball will be awarded from the right ramp at 30 ramp shots. The choices are:

ON = Making 30 ramp shots will light extra ball.

OFF = There is NOT a second ramp extra ball.

#### **A.2 15 Auto-fire Locks**

The operator selects whether or not the ball will auto-fire onto the playfield when a coffin multiball lock is made. \*Note: This also turns off the skill shot on locked balls. The choices are:

YES = Balls will be auto-fired when a lock is made.

NO = Balls will not be auto-fired when a lock is made, the player must press launch button to launch ball.

Factory Default: NO

#### **A.2 16 Coffin Multiball**

This adjustment controls the difficulty of starting coffin multiball (3-Ball Multiball). The choices are:

Extra Easy, Easy, Medium, Hard, Extra Hard

Each choice makes the coffin multiball progressively more difficult to achieve.

Factory Default: Medium

**A.2 17 Crate Multiball**

This adjustment controls the difficulty of starting crate multiball (2-Ball Multiball). The choices are:

Extra Easy, Easy, Medium, Hard, Extra Hard

Each choice makes the crate multiball progressively more difficult to achieve.

Factory Default: Medium

**A.2 18 Ramp Extra Ball Memory**

The operator selects whether or not Extra Balls awarded from the right ramp will remain lit from ball to ball. Choices are:

YES = An extra ball lit from the right ramp will remain lit from ball to ball.

NO = An extra ball lit from the right ramp will be turned off at the end of each ball.

Factory Default: YES

**A.2 19 Spider Extra Ball Memory**

The operator selects whether or not Extra Balls awarded from the Spider game will remain lit from ball to ball. Choices are:

YES = An extra ball lit from the Spider Game will remain lit from ball to ball.

NO = An extra ball lit from the Spider Game will be turned off at the end of each ball.

Factory Default: YES

**A.2 20 Mystery Extra Ball Memory**

The operator selects whether or not Extra Balls awarded from the Telepathic Power feature will remain lit from ball to ball. Choices are:

YES = An extra ball lit from Telepathic Power will remain lit from ball to ball.

NO = An extra ball lit from Telepathic Power will be turned off at the end of each ball.

Factory Default: YES

**A.2 21 Leaper Extra Ball Memory**

The operator selects whether or not Extra Balls awarded from the Leaper mode feature will remain lit from ball to ball. Choices are:

YES = An extra ball lit from Leaper mode will remain lit from ball to ball.

NO = An extra ball lit from Leaper mode will be turned off at the end of each ball.

Factory Default: YES

**A.2 22 Stiff Mode Timer**

Determines the maximum amount of time a player has to complete the stiff-o-meter mode.

Setting: 15 - 60 seconds.

Factory Default: 30 seconds.

**A.2 23 Boogie Mode Time**

The operator selects the amount of time that the Boogie Man Boogie Mode is active once started (setting range 15-40 seconds).

Setting: 15 - 40 seconds.

Factory Default: 20 seconds.

**A.2 24 2x Mode Time**

The operator selects the amount of time that the 2X playfield mode is active once started (setting range 15-45 seconds)

Factory Default: 20 seconds

**A.2 25 Leaper Mode Time**

The operator selects the amount of time that the Leaper mode is active once started (setting range 20-40 seconds)

Factory Default: 20 seconds.

**A.2 26 Beat Mode Timer**

The operator selects the amount of time that Beat the Crate mode is active once started (setting range 15-40 seconds)

Factory Default: 20 seconds.

**A.2 27 Player Tournament**

The operator chooses if holding both flipper buttons for approximately 5 seconds will allow the player to play a game in tournament mode. Choices are:

YES = If player holds both flippers for approximately 5 seconds, they will be allowed to play a game with tournament mode settings.

NO = Tournament mode is NOT available from the flippers. (Tournament mode is still available using the adjustment.)

Factory Default: YES

**A.2 28 Disable Coffin**

The operator chooses if the Coffin Device and the Coffin Diverter device will be utilized. Choices are:

YES = The Coffin Lockup Device AND the Coffin Diverter will NOT be used during game play.

NO = The Coffin Lockup Device AND the Coffin Diverter will be used during game play.

Factory Default: NO

**A.2 28 Disable Crate**

The operator chooses if the Crate device will be utilized. Choices are:

YES = The Crate device will NOT be opened during game play.

NO = The Crate device will be utilized during game play.

Factory Default: NO

**A.2 29 Disable Crate**

The operator chooses if the Crate device will be utilized. Choices are:

YES = The Crate device will NOT be opened during game play.

NO = The Crate device will be utilized during game play.

Factory Default: NO

**A.2 30 Disable Spider**

The operator chooses if the Spider device in the backbox will be utilized. Choices are:

YES = The Spider device will not be utilized. Awards are given randomly.

NO = The Spider device will be utilized during game play.

Factory Default: NO

**A.2 31 Family Mode**

The operator chooses if discretion will be used when playing certain sounds and speech.

OFF = All speech and sounds will be played.

ON = Discretion will be used when playing sounds and speech.

Factory Default: OFF

**A.2 32 Boogie Dancers**

The operator can activate the boogie man dancers feature if available.

OFF = No boogie man dancers.

ON = Boogie man dancers will dance during boogie man mode.

Factory Default: OFF

## **A.3 Pricing Adjustments**

### **A.3 01 Game Pricing (If set to custom, then 02 to 09 are available).**

The cost of a game is selected here, from the Standard Pricing Table or by using the Custom Pricing Editor (A.3 27).

### **A.3 02 thru A.3 09 Not Used**

### **A.3 10 Coin Door Type (If set to custom, then 11 to 15, 20 and 25 are available)**

This adjustment is used to preset adjustments 11 through 15, 20 and 25, based on standard coin doors (U.S.A., German, Etc.).

### **A.3 11 Collection Text**

The coin system used to display the Earning Audits.

### **A.3 12 Left Slot Value**

### **A.3 13 Center Slot Value**

### **A.3 14 Right Slot Value**

### **A.3 15 4th Slot Value**

These are the values for the coins for these respective coin slots. These values are used for determining collection totals. The corresponding adjustments A.3 28 (Left Slot Credit Value) through A.3 31 (4th Slot Credit Value) typically contain the same values and are used to determine the number of credits awarded for the coin slot. Whenever these values are changed, the new value is copied to the corresponding A.3 28 through A.3 31 adjustment. If a bonus is desired for a particular coin (such as 3 credits for dollar coin) then the corresponding A.3 28 through A.3 31 "Credit Value" adjustment should be modified to award the bonus. See "Bonus for Special Coin" section for more information.

### **A.3 16 Maximum Credits**

The maximum number of credits the game can accumulate, either through game play awards or coin purchases. The range of this setting is 5 through 99. Reaching the specified setting prevents the award of any credits. The factory default is 10.

### **A.3 17 Free Play**

The player can operate the game without a coin (free play) or with a coin.

NO - A coin is necessary for game play.  
YES - Game play is free; no coin required.

### **A.3 18 Hide Coin Audits**

The coin audits may, or may not be displayed.

YES - The coin audits are not displayed.  
NO - The coin audits are displayed.  
HIDE NAMES - The coin audit value is shown but not the audit name.

### **A.3 19 Not Used**

### **A.3 20 Base Coin Size**

This is the smallest unit of coin that may be used when creating a custom pricing mode using the Pricing Editor (A.3 27). For example, in the USA this is typically \$0.25. All pricing levels are then specified in 25 cent (or greater) increments.

### A.3 21 Coin Meter Units

This adjustment determines the value of each coin unit on the coin meter. For example, to show the total amount of money collected as "total quarters", set this adjustment to "0.25". To show the total amount of money collected as "total dollars", set this adjustment to "1.00". Setting this adjustment to anything other than OFF establishes the coin unit for the meter install on the Coin Door Interface Board. *Note: All WPC games are cable ready to operate a coin meter mounted to the Coin Door Interface Board. Boards without a meter can use the parts listed below to take advantage of the coin meter feature. The coin meter and spacer may be purchased from you distributor.*

Coin Meter +6V	20-9302-3
Spacer	20-9914

### A.3 22 Dollar Bill Slot

The system normally requires 150 microseconds between coin pulses. This is too long a delay for a fast-pulsing dollar bill validator. This adjustment may be used to tell the game that there is a fast pulsing dollar bill validator connected to one of the coin switches. The options are:

NONE	=	No validator connected.
LEFT	=	Validator connected to left slot.
CENTER	=	Validator connected to center slot.
RIGHT	=	Validator connected to right slot.
FOURTH	=	Validator connected to fourth slot.

### A.3 23 Minimum Coin Milliseconds

This is the minimum width required for coin pulses to be accepted as valid coins. This may be changed to prevent certain kinds of cheating.

### A.3 25 Allow Hundredths

This is used for a custom door specifier. If set to "YES", then the values for A.3 12-15 are specified in units and hundredths (such as dollars and quarters). If set to "NO", then all values are in units (such as Francs and Lire).

### A.3 26 Credit Fraction

This determines the smallest fraction used for credits. It must always be even to accommodate the extra ball buy-in option of 1/2 credit, and is typically 1/2 but may need to be a different value for modes requiring more coins per credit.

### A.3 27 Pricing Editor

This function is now used to enter information for a custom pricing mode. The adjustment A.3 26 (Credit Fraction) may need to be set before entering the Custom Pricing Editor. This specifies the smallest fraction available for partial credits.

Because of the availability of an extra ball (buy-in) for 1/2 credit, this value is always even (1/2, 1/4, 1/6 etc.). The typical setting for A.3 26 is 1/2 (such that there are only full credits and half credits) but you may need to use a different value for other pricing modes.

Please note that formerly, the coin values specified by custom coin door adjustments A.3 12-15 only affected audit totals that showed collection totals. In the 10/94 pricing system, these coin values are added up for each coin received and credits are awarded based on pricing levels being reached. The pricing editor described here allows you to set these levels, however, it may be necessary for you to set A.3 10 (Coin Door Type) to "CUSTOM" and then change A.3 11-15, 20 and 25 to reflect the value of the coins being used. This is usually NOT NECESSARY, but must be done BEFORE using the custom pricing editor when it is necessary.

Begin the custom pricing function by pressing the "Enter" button while A.3 27 "PRICING EDITOR" is showing on the display.

The pricing editor will now show the data for the currently selected pricing mode. If this is the 1st use of the pricing editor then this will show the last built-in pricing that was selected. Otherwise it will be the last custom mode created by this function. (Note that A.3 01 will display "Custom" any time a non-standard pricing has been used.)

Assuming that last mode installed was 1/\$0.50 2/\$0.75 3/\$1.00 the display will appear as follows:

Custom Pricing Editor		
1)	\$0.25	1/2 cred.
2)	\$0.50	1 cred.
3)	\$0.75	2 cred.
4)	\$1.00	3 cred.

Display View

The "\$0.25" field will be flashing. You may now use the test mode buttons to perform the following functions:

- Escape:* Undo any changes to the current field and move to the previous field.
- "-" (Down):* Make the current field lower.
- "+" (Up):* Made the current field higher.
- Enter:* Save any change to the current field and move to the next field. Note that there are two columns of fields. Price levels are in the left column and credit levels are in the right column. Pressing "Enter" will move from the left column to the right column before moving to the next line.
- Start:* Save the current custom price mode or start over.

By using the above functions, simply enumerate each pricing level and the number of credits that should be awarded at that level. Please note that you must specify each fractional level in the sequence.

Example:	1/\$0.50	2/\$1.00	4/\$1.50	6/\$2.00
	1)	\$0.25	1/2 cred.	
	2)	\$0.50	1 cred.	
	3)	\$0.75	1 1/2 cred.	
	4)	\$1.00	2 cred.	
	5)	\$1.25	2 1/2 cred.	
	6)	\$1.50	4 cred.	
	7)	\$1.75	4 1/2 cred.	
	8)	\$2.00	6 cred.	



Also note that once the value of the coins repeat that no further specification is necessary.

Example:      1/\$0.50      2/\$1.00  
                      1)      \$0.25      1/2 cred.

In the above example, only one line needs to be specified, indicating that 1/2 credit is awarded for each \$0.25 received.

**Special Features:**

There are some special features available by pressing the “-” (Down) button while in the left column. The following words will be displayed instead of a pricing level:

*End*  
*Delete*  
*Insert*  
*Clear*  
*Repeat 1*  
*Repeat 2*  
*Repeat 3*  
*Repeat 4*  
*Repeat 5*  
*Repeat 6*  
*Repeat 7*  
*Repeat 8*  
*Repeat 9*  
*Repeat 10*  
*Repeat 11*  
*Repeat 12*  
*Repeat 13*  
*Repeat 14*  
*Repeat 15*  
*Repeat 16*  
*Repeat 17*  
*Repeat 18*  
*Repeat 19*  
*Repeat 20*

Pressing “Enter” with the above words selected will activate the following functions:

**End** This is the same as pressing the start button. A menu of choices will be provided (see “Start Button” below).

**Delete** This will delete the current level from the pricing mode.

**Insert** This will insert a new pricing level ABOVE the current level. The current level will be unaffected. There must be room for at least 1 coin between the current level and the previous level, and at least one fractional credit unit between the current level and the previous level.

Example: Inserting a new pricing level.

Custom Pricing Editor		
1)	\$0.50	1 cred.
2)	\$1.00	2 cred.
3)	\$1.50	4 cred.
4)	\$2.00	6 cred.

Display View

Use the "Enter" button to move to the \$1.50 field. Now press the "-" button once to create the following display:

Custom Pricing Editor		
1)	\$0.50	1 cred.
2)	\$1.00	2 cred.
3)	INSERT	4 cred.
4)	\$2.00	6 cred.

Display View

Now press the "Enter" button. The display will now show:

Custom Pricing Editor		
1)	\$0.50	1 cred.
2)	\$1.00	2 cred.
3)	\$1.25	2 1/2 cred.
4)	\$1.50	4 cred.

Display View

Note that the line "5) \$2.00 6 cred." no longer fits on the display. Whenever there are more than 4 pricing levels the display will scroll up and down as "Enter" and "Escape" are used to move from field to field. If you repeatedly press "Enter" the display will then show:

Custom Pricing Editor		
2)	\$1.00	2 cred.
3)	\$1.25	2 1/2 cred.
4)	\$1.50	4 cred.
5)	\$2.00	6 cred.

Display View

**Clear** This will clear out the current entries to allow a new price mode to be entered.

**Repeat (1-20)** This will cause all entries above the current line to be repeated the number of times specified. This is only available when there are no pricing levels below the current line.

Example: 1/\$0.50      2/\$1.00      15/\$5.00

Use the "Edit New Pricing Mode" feature described below to clear out the current levels.

Use "+" and "Enter" to specify 1/2 credit for \$0.25:

Custom Pricing Editor		
1)	\$0.25	1/2 cred.

Display View

Now, use "-" until the display shows "Repeat 20". The display will show the following:

Custom Pricing Editor		
1)	\$0.50	1 cred.
2)	REPEAT 20	

Display View

Press "Enter" and the display will show the following:

Custom Pricing Editor		
1)	\$0.25	1/2 cred.
2)	\$0.50	1 cred.
3)	\$0.75	1 1/2 cred.
4)	\$1.00	2 cred.

Display View

Actually, by repeating the 1st line 20 times the pricing mode is currently set up as follows, but only the 1st 4 lines are displayed.

Custom Pricing Editor		
1)	\$0.25	1/2 cred.
2)	\$0.50	1 cred.
3)	\$0.75	1 1/2 cred.
4)	\$1.00	2 cred.
5)	\$1.25	2 1/2 cred.
6)	\$1.50	3 cred.
7)	\$1.75	3 1/2 cred.
8)	\$2.00	4 cred.
9)	\$2.25	4 1/2 cred.
10)	\$2.50	5 cred.
11)	\$2.75	5 1/2 cred.
12)	\$3.00	6 cred.
13)	\$3.25	6 1/2 cred.
14)	\$3.50	7 cred.
15)	\$3.75	7 1/2 cred.
16)	\$4.00	8 cred.
17)	\$4.25	8 1/2 cred.
18)	\$4.50	9 cred.
19)	\$4.75	9 1/2 cred.
20)	\$5.00	10 cred.

Now, repeatedly press "Enter" to move to the right hand column of the 20th level. The display will show (with "10 cred." blinking):

Custom Pricing Editor		
17)	\$4.25	8 1/2 cred.
18)	\$4.50	9 cred.
19)	\$4.75	9 1/2 cred.
20)	\$5.00	10 cred.

Display View

Now, press "+" repeatedly until the right hand column of line 20) reads "15 cred."

**Start Button:** Once the pricing mode has been specified, exit the custom pricing editor by pressing the "Start" button. This will bring up a menu with (some or all of) the following choices:

Choose an Option:
Return to Editor
Clear Pricing
Ignore Changes
Save Changes

Display View

Use the "+" and "-" button to select your choice and press the "Enter" button to activate. The selections cause the following actions:

**Return to Editor:** This option will allow you to continue to edit the pricing information.

**Clear Pricing:** This option will clear out all pricing levels and bring you back to the pricing editor to create a pricing mode from scratch.

**Ignore Changes:** This option will discard the work done in the pricing editor and leave the previously installed pricing mode in the game.

**Save Changes:** Press "Enter" to save your custom edited pricing mode and install it as the pricing for the game. Note that this choice will not be displayed if there is not at least one pricing level specified in the pricing editor, or if no changes have been made.

**Exit Pricing Editor:** This option will appear if no changes have been made. It will exit the Pricing Editor leaving the pricing as is.

## Bonus for Special Coins

For most coin modes, the system allows the mixing of any combination of any size coin and awards credits as each appropriate amount is accumulated. With A.3 10 (Coin Door Type) set to "custom", the value of each coin slot may be entered for adjustments A.3 12 (Left slot value) through A.3 15 (4th slot value). Whenever these values are changed, the new values are copied to A.3 28 (Left Slot Credit Value) through A.3 31 (4th Slot Credit Value) respectively. To give a bonus for a particular coin, you need to modify the "Credit Value" adjustment to specify the value to be given for the bonus coin.

For example, in a game with a Left Coin Slot that takes quarters and a center coin slot that takes dollars, if you wish to charge 50 cents for 1 play and \$1.00 for 2 plays, you setup the pricing editor to show:

- |    |        |            |
|----|--------|------------|
| 1) | \$0.25 | 1/2 Cred   |
| 2) | \$0.50 | 1 Cred     |
| 3) | \$0.75 | 1 1/2 Cred |
| 4) | \$1.00 | 2 Cred     |

If you set A.3 10 (Coin Door Type) to "custom" you will see the following coin door specifier adjustments:

A.3 12	Left Slot Value	0.25
A.3 13	Center Slot Value	1.00
A.3 28	Left Slot Credit Value	0.25
A.3 29	Center Slot Credit Value	1.00

To change the pricing to 1 play for \$0.50, 2 plays for \$1.00 and 3 plays for a dollar coin, you change A.3 29 (Center Slot Credit Value) to 1.50. This will result in the following settings:

A.3 12	Left Slot Value	0.25
A.3 13	Center Slot Value	1.00
A.3 28	Left Slot Credit Value	0.25
A.3 29	Center Slot Credit Value	1.50

This will cause \$1.50 worth of credits (3) to be awarded for each coin inserted in the center coin slot (dollar coin). This is due to the \$1.50 setting of A.3 29 (Center Slot CREDIT VALUE). Note that the 1.00 setting of A.3 13 tells the game that each coin in the center slot adds \$1.00 to the total collection.

### **A.3 28 Left Slot Credit Value**

### **A.3 29 Center Slot Credit Value**

### **A.3 30 Right Slot Credit Value**

### **A.3 31 4th Slot Credit Value**

This adjustment specifies the value to be used for awarding credits. It is typically the same value as the corresponding A.2 12 (Left Slot Value) through A.2 15 (4th Slot Value) adjustment.

The A.3 12 through A.3 15 values are used to determine the auditing value of each coin (for collection totals) while the A.3 28 through A.3 31 value determine the coin value for awarding credits. By making this "Credit Value" adjustment higher than the A.3 12 through A.3 15 "Value" adjustment, a bonus may be given for a specific call (see "Bonus for Special Coin" section for more information).

### Pricing Table

Country	Coin Chutes				Game/Coins	Display	Pricing Adjustments A3 02 03 04 05 06 07 08 09
	Left	Center	Right	4th Chute			
USA	25c	\$1.00*	25c	\$1.00	1/50c, 2/75c, 3/\$1 <sup>2</sup>	50c, 75c, \$1.00	
	25c	\$1.00*	25c	\$1.00	1/75c, 2/\$1.50, 3/\$2.00 <sup>2</sup>	1/75, 3/2.00	
	25	\$1.00	25c	\$1.00	1/3X25c <sup>2</sup>	USA1 1/\$0.75	
	25	\$1.00	25c	\$1.00	1/50c, 2/\$1 <sup>2</sup>	USA 2/\$1.00	
	25	\$1.00	25c	\$1.00	1/50c, 3/\$1.00 <sup>2</sup>	USA 3/\$1.00	
	25	\$1.00	25c	\$1.00	1/2x25c, 2/\$1.00, 3/\$1.50, 6/\$2.00 <sup>2</sup>	USA 6/\$2.00	
	25	\$1.00	25c	\$1.00	1/2x25c, 2/\$1.00, 3/\$1.50, 5/\$2.00 <sup>1,2</sup>	USA 5/\$2.00	
	25	\$1.00	25c	\$1.00	1/3X25c, 2/\$1.50, 4/\$2.00 <sup>2</sup>	1/75, 4/\$2.00	
	25	\$1.00	25c	\$1.00	1/2x25c, 2/\$1.00, 4/\$1.50, 6/\$2.00 <sup>2</sup>	6/\$2.00 4/\$1.50	
	25c	25c	25c	-	1/4x25c, 6/\$5.00 <sup>2</sup>	1/1, 6/5	
	25c	25c	25c	-	1/4x25c <sup>2</sup>	1/\$1.00	
Canada	25c	-	\$1.00*	-	1/50c, 2/75c, 3/\$1 <sup>2</sup>	CAN. 50-75-1	
	25c	-	\$1.00	-	1/50c, 2/\$1 <sup>2</sup>	CAN. 2/\$1.00	
	25c	-	\$1.00	-	1/50c, 2/\$1.00, 3/\$1.00 <sup>2</sup>	CAN. 3/\$1.00	
	25c	-	\$1.00	-	1/2x25c, 2/4x25c, 3/\$1.00 <sup>2</sup>	3/\$1.00 Coin	
	25c	-	\$1.00	-	1/2x25c, 2/\$1.00, 3/\$1.50, 6/\$2.00 <sup>2</sup>	CAN. 6/\$2.00	
	25c	-	\$1.00	-	1/2x25c, 2/\$1.00, 3/\$1.50, 5/\$2.00 <sup>1,2</sup>	CAN. 5/\$2.00	
	25c	-	\$1.00	-	1/2x25c, 2/\$1.00, 4/\$1.50, 6/\$2.00 <sup>2</sup>	6/\$2 4/1.50	
	25c	-	\$1.00	-	1/3X25c, 2/\$1.50, 4/\$2.00 <sup>2</sup>	1/75, 4/2.00	
	25c	-	\$1.00*	-	1/75c, 2/\$1.50, 3/\$2.00 <sup>2</sup>	1/75, 3/2.00	
	25c	-	\$1.00	-	1/3X25c <sup>2</sup>	CAN. 1/\$0.75	
Austria	5sch	10sch	10sch	-	1/2x5sch, 3/2x10sch <sup>2</sup>	AUSTRIA	
Australia	5sch	-	10sch	-	2/5sch, 5/10sch	CUSTOM	02 00 05 00 01 00 01 00
Australia	20c	\$1	\$1	\$2	1/\$1, 3/\$2 <sup>2</sup>	AUSTRALIA 1	
Australia	20c	\$1	\$1	\$2	1/\$1, 2/\$2	AUSTRALIA 2	
U.K.	£1.00	50P	20P	10P	1/3x10P, 2/50P, 4/£1 <sup>2</sup>	U. KINGDOM	
Switzerland	1Fr	2Fr	5Fr	-	1/1Fr, 3/2Fr, 7/5Fr <sup>2</sup>	SWISS 1	
	1Fr	2Fr	5Fr	-	1/2Fr, 2/3Fr, 3/4Fr, 5/5Fr	SWISS 2	
	1Fr	2Fr	5Fr	-	1/1Fr, 5/5Fr	SWISS 3	
	1Fr	2Fr	5Fr	-	1/1Fr, 2/2Fr, 6/5Fr	SWISS 4	
	1Fr	1Fr	1Fr	-	1/1Fr (All Slots = 1Fr) <sup>1</sup>	SWISS 5	
Belgium	5Fr	20Fr	50Fr	-	1/4x5Fr, 1/20Fr, 3/50Fr <sup>2</sup>	BELGIUM 1	
	5Fr	20Fr	50Fr	-	1/20Fr, 3/50Fr, 3/50Fr	BELGIUM 2	
Germany	1DM	2DM	5DM	-	1/2DM, 2/3DM, 3/4DM, 4/5DM <sup>1,2</sup>	GER. 4/5DM	
					1/2DM, 2/3DM, 3/4DM, 5/5DM <sup>1,2</sup>	GER. 1/2DM	
					1/1DM, 2/2DM, 5/5DM <sup>2</sup>	GER. 1/1DM	
					1/1DM, 2/2DM, 6/5DM <sup>2</sup>	GER. 6/5DM	
Holland	1G	-	1G	-	1/1G <sup>2</sup>	HOLLAND	
Sweden	1Kr	5Kr	10Kr	1Kr	1/10Kr, 2/15Kr, 3/20Kr <sup>1,2</sup>	SWEDEN 1	
	1Kr	5Kr	10Kr	1Kr	1/5Kr <sup>2</sup>	SWEDEN 2	
France	1Fr	5Fr	10Fr	20Fr	1/3x1Fr, 2/5Fr, 5/10Fr, 10/20Fr <sup>2,3</sup>	TARIF 1	
	1Fr	5Fr	10Fr	20Fr	1/2x1Fr, 3/5Fr, 7/10Fr, 14/20Fr <sup>2,3</sup>	TARIF 2	
	1Fr	5Fr	10Fr	20Fr	1/5Fr, 3/10Fr, 7/2x10Fr, 7/20Fr <sup>1,2,3</sup>	TARIF 3	
	1Fr	5Fr	10Fr	20Fr	2/5Fr, 4/10Fr, 9/2x10Fr, 9/20Fr <sup>2,3</sup>	TARIF 4	
	1Fr	5Fr	10Fr	20Fr	2/5Fr, 5/10Fr, 11/2x10Fr, 11/20Fr <sup>2,3</sup>	TARIF 5	
	1Fr	5Fr	10Fr	20Fr	1/5Fr, 3/10Fr, 8/20Fr <sup>2,3</sup>	TARIF 6	
Italy	500L	500L	500L	-	1/500L <sup>2</sup>	ITALY 1	
	500L	500L	500L	-	1/2x500L, 3/4x500L <sup>1,2</sup>	ITALY 2	
	500L	500L	500L	-	1/2x500L, 2/4x500L <sup>2</sup>	ITALY 3	
Spain	100P	-	500P	-	1/100P, 8/500P <sup>2</sup>	SPAIN	
	25P	-	100P	-	1/25P, 5/100P	CUSTOM	01 00 04 00 01 04 01 00
	25P	-	100P	-	1/25P, 4/100P	CUSTOM	01 00 04 00 01 00 01 00
	25P	-	100P	-	1/2x25P, 2/100P	CUSTOM	01 00 04 00 02 00 01 00
Japan	100Y	-	100Y	-	1/2x25P, 3/100P	CUSTOM	03 00 12 00 04 00 01 06
Japan	100Y	-	100Y	-	1/100Y <sup>2</sup>	JAPAN	
Chile	Token	-	Token	-	1/1Token <sup>2</sup>	CHILE	
Denmark	1Kr	5Kr	10Kr	20Kr	1/2x1kr, 3/5kr, 7/10kr <sup>2</sup>	DENMARK 1	
	1Kr	5Kr	10Kr	20Kr	1/5kr, 3/10kr, 8/20kr <sup>1,2</sup>	DENMARK 2	
Finland	1Mka	-	5Mka	-	1/2x1Mka, 3/5Mka <sup>2</sup>	FINLAND 1	
	1Mka	-	5Mka	-	1/3x1Mka, 2/5Mka <sup>2</sup>	FINLAND 2	
New Zealand	\$1.00	-	\$2.00	-	1/\$1, 3/\$2 <sup>2</sup>	NEW ZEALAND 1	
	\$2.00	-	\$1.00	-	1/\$1, 3/\$2, (\$2-\$1 door)	NEW ZEALAND 2	
Norway	5Kr	-	10Kr	-	1/5Kr, 2/10Kr, 5/20Kr <sup>2</sup>	NORWAY	
Argentina	10c	10c	10c	-	1/1Token <sup>2</sup>	ARGENTINA	
Greece	10D	20D	50D	-	1/2x10D, 1/20D, 3/50D	GREECE	
Antilles	25c	25c	1G	-	1/25c, 4/1G	ANTILLES	
Netherlands	1Hfl	2.5Hfl	2.5Hfl	-	1/1Hfl, 3/2.5Hfl	NETHERLANDS 1	
	1Hfl	2.5Hfl	2.5Hfl	-	1/1Hfl, 3/3Hfl, 3/2.5Hfl	NETHERLANDS 2	
Hungary	20 Old	20 New	50F	-	1/40F, 2/60F, 4/100F <sup>2</sup>	HUNGARY	

Note: 1. Factory Default. 2. Standard Setting - Change by pressing Enter button. 3. Other functions are also affected.

\* Only if Bill Acceptor and Center Coin Chute are available.

## **A.4 H.S.T.D. Adjustments**

### **A.4 01 Highest Scores**

The game maintains a record of the four highest scores achieved to date.

- OFF - No high scores are recorded, or displayed.
- ON - The four highest scores are stored in memory and displayed in the Attract Mode.

### **A.4 02 H.S.T.D. Award**

The award given for achieving the High Score To Date, or the Champion H.S.T.D: Credit or Token.

### **A.4 03 Champion H.S.T.D.**

The "Highest" High Score is displayed in the Attract Mode. This score is not cleared when "High Score Reset Every" occurs.

- ON - The "Highest" High Score is retained in memory and is displayed.
- OFF - The "Highest" High Score is not retained.

### **A.4 04 Champion Credits**

The operator chooses the number of credits or tickets awarded for a Grand Champion Score.

Range: 00 - 10.

### **A.4 05 H.S.T.D. 1 Credits**

### **A.4 06 H.S.T.D. 2 Credits**

### **A.4 07 H.S.T.D. 3 Credits**

### **A.4 08 H.S.T.D. 4 Credits**

The number of credits or tickets to be awarded whenever a player exceeds the 1st, 2nd, 3rd, and 4th highest scores.

Range: 00 - 10.

### **A.4 09 High Score Reset Every**

The number of games to be played before an automatic reset of the displayed "Highest Score" occurs. The values provided upon reset are those selected by the operator in the Back-up High Scores.

Range: OFF (disabled); 250 to 20,000.

### **A.4 10 Backup Champion**

The Back-up Grand Champion Score.

Range: 00 - 9,500,000,000.

**A.4 11 Backup H.S.T.D. 1**

**A.4 12 Backup H.S.T.D. 2**

**A.4 13 Backup H.S.T.D. 3**

**A.4 14 Backup H.S.T.D. 4**

The first through the fourth Back-up High Score values. The game automatically restores this value when the High Score Reset Every value is reached.

Range: 00 - 9,500,000,000.



## **A.5 Printer Adjustments** (optional board required)

### **A.5 01 Column Width**

The column width to be printed. Range: 22 - 80.

### **A.5 02 Lines Per Page**

The amount of lines per page. Range: 20 - 80.

### **A.5 03 Pause Every Page**

Choose whether the printer pauses at the end of a page.

YES - The printer does pause.

NO - The printer does not pause.

### **A.5 04 Printer Type**

Select the type of printer. Choices: Parallel, Serial, ADP., Mini-Drucker, or NSM.

### **A.5 05 Serial Baud Rate**

The baud rate used for Serial or ADP communications (bit rate). Choices: 300, 600, 1200, 2400, 4800, or 9600.

### **A.5 06 Serial D.T.R. (Data Terminal Ready)**

When a Serial Printer is used, this line may be connected to a printer output line signaling that the printer is busy.

Normal - Normal D.T.R. signal goes low to indicate the printer is not ready.

Inverted - Inverted D.T.R. (busy) signal goes high to indicate printer is not ready.

Ignore - D.T.R. signal is ignored.

### **A.5 07 Auto Printout**

With the optional printer board installed, this adjustment allows the initiation of printouts whenever the game detects a printer connected to the game. Parallel printers are detected automatically by plugging them in and putting them on-line. Serial printers (or computers) are detected by sending a carriage return (ASCII 0x0D) or XON (ASCII 0x11).

This adjustment has the following settings:

OFF	Disable automatic printouts
MAIN AUDES	Main Audit table (B.1)
EARNINGS	Earning Audits (B.2)
STD. AUDITS	Standard Audits (B.3)
FEATURES	Feature Audits (B.4)
HISTOGRAMS	Histograms (B.5)
TIMESTAMPS	Time Stamps (B.6)
ALL DATA	All of the above data

The table specified above will automatically be printed when a printer (or computer) is detected.

If the printer is detected during game over or test mode, the printout will take place right away.

If the printer is connected while a game is being played, it will take up to 10 seconds to be detected, after which the printout will occur. The game will resume after the printout is complete.

Automatic printout will only take place if the coin door is open.

After an automatic printout has been generated, a second automatic printout will not be possible until a new game has started, or test mode begins.

## ERROR MESSAGES

The WPC game program has the capability to aid the operator and service personnel. At game turn-on, or after pressing the Begin Test switch, once the game has been operating for an extended period, the display may signal with a message, "Press ENTER for Test Report". This indicates the game program has detected a possible problem with the game.

To obtain details of the problem open the coin door and press the Begin Test switch. Press the Enter button to begin displaying the message(s). The following messages apply to your game.

### **Check Switch ##.**

This message indicates that at least one switch was stuck 'On' at game turn-on or has NOT been actuated during ball play (for 60 balls or approximately 20 games). The game program compensates the game play requirements affected by each disabled switch to allow 'nearly normal' play. This helps keep your game earning, until the service technician can repair the problem. To verify the problem, refer to the Test Menu text describing Switch Testing, and check each reported switch using applicable switch tests. Always check switch operation using a ball, to simulate game conditions. Switch problems may often be resolved by adjusting the wire switch actuators, fixing switch circuitry problems, securing loose connectors, etc. Mechanisms using 'opto switches' (ball poppers, etc.) need to be checked for proper power connections (+12V dc and ground).

### **Check Fuses F101 and F106 and Opto 12V Supply**

This message will be displayed if the game senses that all optical switches are not functioning. This usually occurs when there is no 12V supply to the playfield optics.

The problem is likely to be a blown fuse (F109), or at connectors J138, J139, J140 or J141 on the power driver board.

### **Opto Trough Bad Check Connectors, Wires and 12V Supply.**

This message will be displayed if all of the optics in the playfield ball trough are not functioning. This is usually caused by a problem with a ball trough connector supplying 12V and ground for the optical circuits.

### **Pinball Missing.**

This game normally uses four balls, however, it will operate with less. This message announces that a ball is missing or stuck. When the ball is located, return it to the Ball Trough. Other possibilities for this problem could be malfunctions of the Ball Trough switches or the Ball Shooter switch.

### **xxxxx Sw. Is Stuck On.**

This message indicates that a switch, which is not usually On, remains in the On position after the game is switched On. The stuck switch is essential for game play (for example, a coin chute switch, the slam tilt switch, the plumb bob tilt switch), and should be cleared to permit proper game operation.

**Ground Short Row - N, Wht - xxx.**

This message indicates that the switch wires being called out are touching a grounded part on the playfield or coin door. The following should be checked:

1. Slam tilt (or other coin door switch) touching the grounded coin door.
2. A leaf-type, playfield switch touching a grounded part.
3. Players poking metallic objects (wires, coat hangers, etc.) into the game.
4. Switch cable insulation pierced or damaged allowing bare wire contact with a grounded part.
5. All switches in a row closing at the same time. **Note:** This is NOT a switch problem; however, for most games it is a very rare possibility.

**G10 Error**

The security chip is incorrect or faulty. If this occurs, replace the security chip.

**G11 Checksum Error.**

The game ROM checksum is invalid. If this occurs replace the game ROM.

**Time and Date Not Set.**

The real time clock is not set. Go to U.4 of the Utilities Menu and set the time and date.

**Factory Settings Restored.**

This message indicates that the CMOS RAM (U8) no longer retains any custom Pricing or Game Adjustment settings and has reverted to factory default settings. Generally, the following CPU checks will isolate the cause of the CMOS RAM memory failure. The voltages at pin 28 and pin 26 of U8 should be +5V (game turned On) and at least +4V (game turned Off). When the voltage drops below +4V, memory reset occurs. Check the batteries and battery holder. Be sure that the batteries are good and that there is no contamination on the battery holder terminals. Turn the game OFF, and use an ohmmeter to check diodes D1 and D2 on the CPU Board. D1 should read 0 ohms when forward-biased and infinite ohms when reverse-biased. D2 should read 15 ohms when forward-biased and infinite ohms when reverse-biased. (Readings taken with an analog meter.) This message can also indicate that there is an open diode on a 50V coil circuit and noise is entering the circuit.

**CPU and Audio Visual Board Error Codes**

The CPU has three LED's, 201, 202, and 203. At game turn-on, LED 201 and LED 202 are on, LED 203 is off. During normal operation LED 201 is off, LED 202 is on, and LED 203 is flashing. If the system detects an error the following happens:

<b><u>CPU BOARD</u></b>	Center LED blinks once	= G11 ROM Failure
<b><u>LED ERROR CODES</u></b>	Center LED blinks twice	= U8 RAM Failure
	Center LED blinks three times	= G10 Security Chip Failure

Upon game turn-on you will hear one of the following.

<b><u>AUDIO VISUAL BOARD</u></b>	1 Beep	= Audio Visual Board is O.K.
<b><u>BEEP ERROR CODES</u></b>	2 Beeps	= S2 Failure
	3 Beeps	= S3 Failure
	4 Beeps	= S4 Failure
	5 Beeps	= S5 Failure
	6 Beeps	= S6 Failure
	7 Beeps	= S7 Failure
	10 Beeps	= Audio Static RAM Failure

### Opto Theory

The opto receiver (Photo Transistor) should be approximately 0.1 - 0.7 volts when the opto beam is unblocked and approximately 11 - 13 volts when the opto beam is blocked. The opto transmitter (LED) should always be approximately 1.4 volts. **Note:** The transmitter (LED) is larger than the receiver (Photo Transistor); it protrudes further from its case.

LED Board (A-16908)  
Transmitter  
1.0-1.1 Volts

Photo Transistor Board (A-16909)  
Receiver  
0.1-0.7V Unblocked  
11-13V Blocked

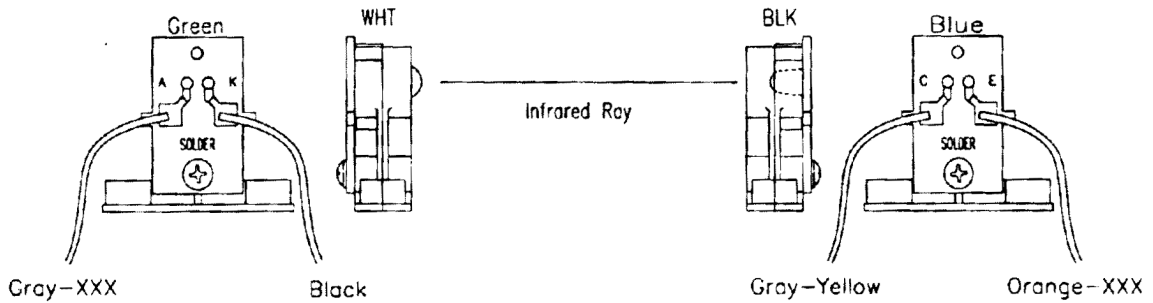

## LED LIST

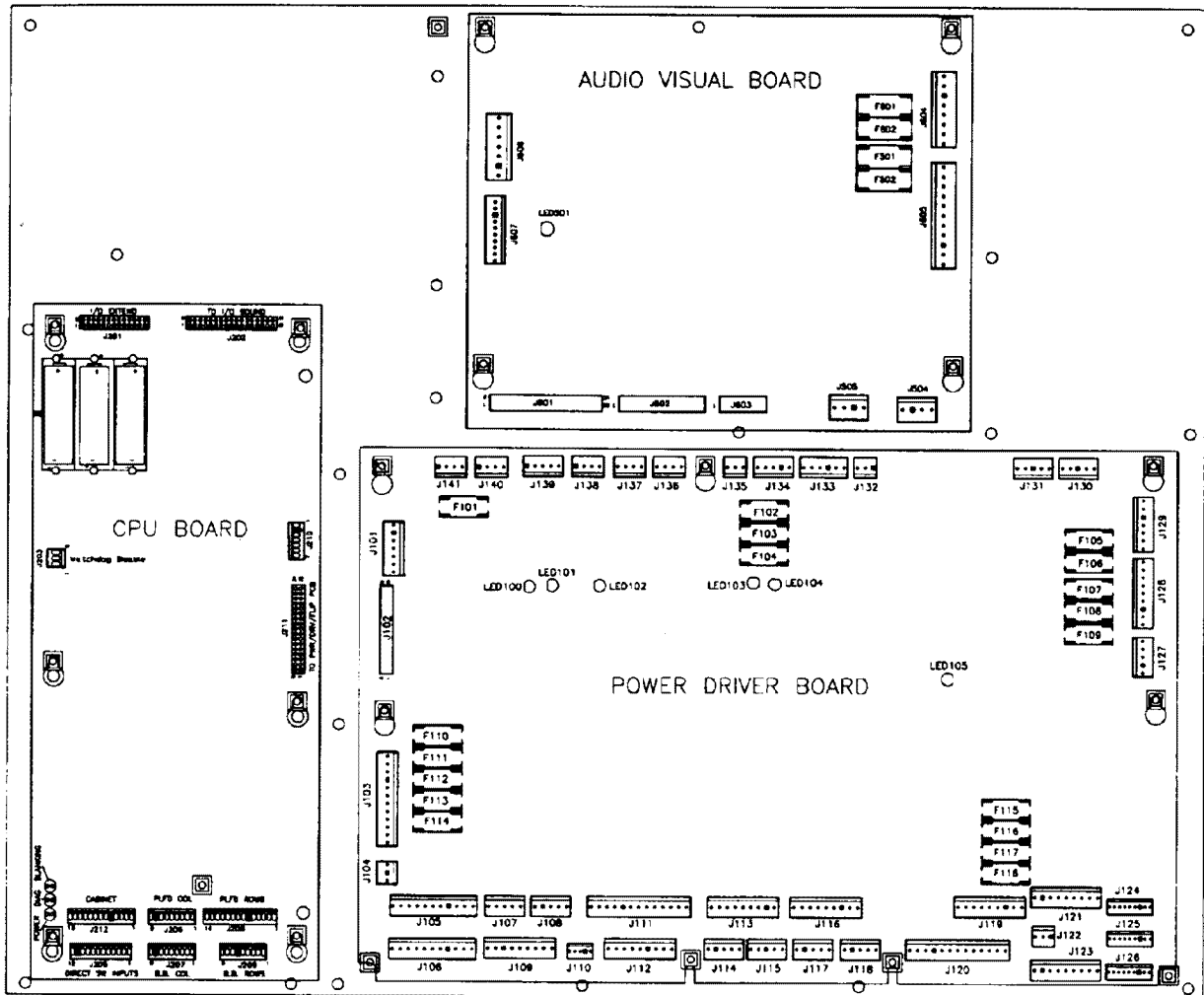

### CPU BOARD

- LED 201      Blanking
- LED 202      Power
- LED 203      Diagnostics

At game turn-on, LED 201 and LED 202 are on, LED 203 is off.  
 During normal operation LED 201 is off, LED 202 is on, and LED 203 is flashing.

### AUDIO VISUAL BOARD

- LED 501      +5VDC, Normally Flashing at a slower rate than LED 203.

### POWER DRIVER BOARD

- LED 100      +12VDC Regulated, Normally On
- LED 101      +5VDC Digital, Normally On
- LED 102      +18VDC Lamps, Normally On
- LED 103      +12VDC Unregulated, Normally On
- LED 104      +20VDC Flashlamps, Normally On
- LED 105      +50VDC Coils, Normally On

## FUSE LIST

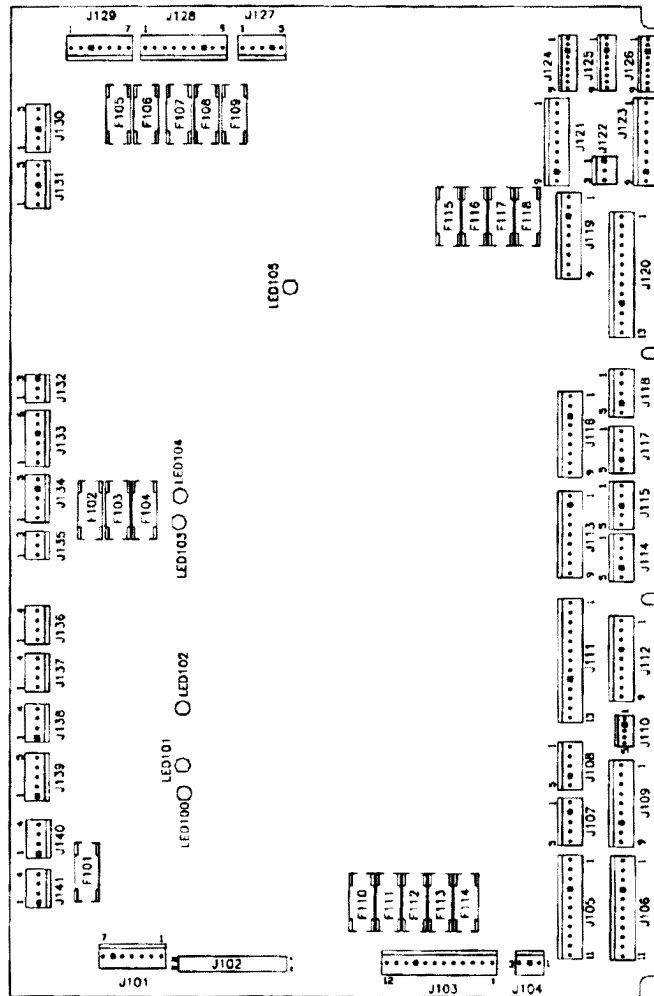

### POWER DRIVER BOARD

Loc.	Description	Part Number	Value
F101	Regulated 12V	5731-14531-00	T0.63A, 250v
F102	Solenoids #9 to #16	5731-14530-00	T4.0A, 250V
F103	Solenoids #1-#8	5731-14530-00	T4.0A, 250V
F104	Solenoids #25 to #28	5731-14530-00	T4.0A, 250V
F105	+5V Logic	5731-14530-00	T4.0A, 250V
F106	+18V Lamp Matrix	5731-14046-00	T5.0A, 250V
F107	Flasher Secondary	5731-14530-00	T4.0A, 250V
F108	Solenoid Secondary	5731-14529-00	T6.3A, 250V
F109	Unregulated 12V	5731-14530-00	T4.0A, 250V
F110	G.I. #5 White-Violet	5731-14530-00	T4.0A, 250V
F111	G.I. #4 White-Green	5731-14530-00	T4.0A, 250V
F112	G.I. #3 White-Yellow	5731-14530-00	T4.0A, 250V
F113	G.I. #2 White-Orange	5731-14530-00	T4.0A, 250V
F114	G.I. #1 White-Brown	5731-14530-00	T4.0A, 250V
F115	+50V Flippers	5731-14530-00	T4.0A, 250V
F116	+50V Flippers	5731-14530-00	T4.0A, 250V
F117	+50V Flippers	5731-14530-00	T4.0A, 250V
F118	+50V Flippers	5731-14530-00	T4.0A, 250V

## FUSE LIST

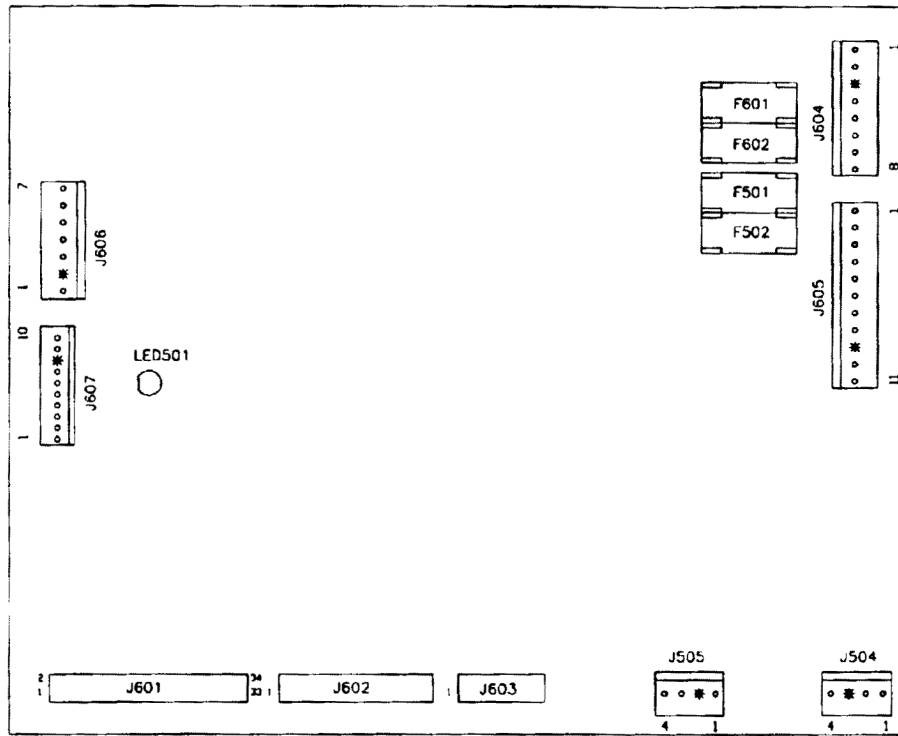

### AUDIO VIDEO BOARD

Loc.	Description	Part Number	Value
F501	-15V	5731-14532-00	T2.5A, 250V
F502	+15V	5731-14532-00	T2.5A, 250V
F601	+62V	5731-14840-00	T0.315A, 250V
F602	-113V & -125V	5731-14840-00	T0.315A, 250V

### LINE FILTER

Loc.	Part Number	Value
Foreign	5731-14530-00	T4.0A, 250V
Domestic	5731-14046-00	T5.0A, 250V

## MAINTENANCE INFORMATION

### LUBRICATION

The two main lubrication points of the Ball Eject mechanism\* are the pivots for the arm. The mechanisms of other playfield devices are somewhat similar and have the same lubrication requirements. A medium viscosity oil (switch target grease) is satisfactory for these devices. Also, regularly lubricate the slide-mechanism rails and the leg levers.

Because of the functional design (arm-actuated via solenoid plunger operation), the pivot points of the Left and Right Kickers ("Slingshots") all require lubrication as a regular servicing procedure.

Lubrication to ensure proper operation also applies to the target blades of Drop Targets. MBI Instrument Grease, also known as Drop Target Switch Lubricant, (Bally part number of EI 165), is a recommended lubricant.

### SWITCH CONTACTS

#### Playfield Switches

For proper game operation, switch contacts should be free of dust, dirt, contamination, and corrosion. Blade switch contacts are plated to resist corrosion. Cleaning blade switch contacts requires gentle closing of the contacts on a clean business card or piece of paper, and then pulling the paper about 2 inches, which should restore the clean contact surface. Adjust the switch contacts to a 1/16-inch gap.

#### Flipper Switches

This game uses the new Fliptronic II Electronic Flipper System. The end-of-stroke switches are NORMALLY OPEN and should close when the flipper is energized. All end-of-stroke switches are gold flashed computer grade leaf switches. Only low computer current is carried through these switches. DO NOT FILE or abrasively clean these switches! DO NOT REPLACE these switches with the old style tungsten high current type switches, as intermittent operation could occur. Please note that unlike the old style of flipper, an end-of-stroke switch failure will not harm the flipper. The game will notify the operator of a misadjusted switch in the test report, but will continue to play. The end-of-stroke switches are a means by which the new electronic flippers feel and play with all of the subtleties of the old flippers.

### CLEANING

Good game action and extended playfield life are the results of regular playfield cleaning. During each collection stop, the playfield glass should be removed and thoroughly cleaned and the playfield should be wiped off with a clean, lint-free cloth. The game balls should be cleaned and inspected for any chips, nicks, or pits. Replace any damaged balls to prevent playfield damage.

Regular, more extensive, playfield cleaning is recommended. However, avoid excessive use of water and caustic or abrasive cleaners because they tend to damage the playfield surface. Playfield wax (or any carnauba based wax), or polish may be used sparingly, to prevent a buildup on the playfield surface. Do not use cleaners containing petroleum distillates on any playfield plastics because they may dissolve the plastic material or damage the artwork.

\*May not be used on all games.





# **SECTION TWO**

## **GAME PARTS INFORMATION**

## 50048-BB Backbox Assembly

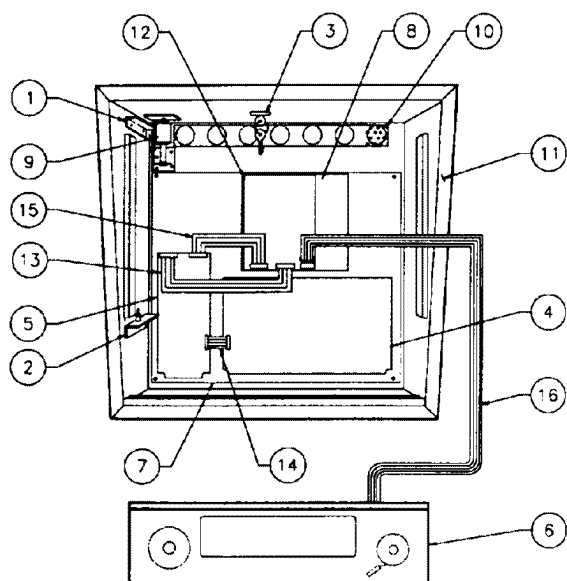

Item	Part Number	Description
1	A-12497	Insert Hinge Assy., Upper
2	A-12498	Insert Hinge Assy., Lower
3	A-13379	Lock & Plate Assembly
4	A-20028	WPC'95 Power Driver Assy.
5	<b>A-21377-50048</b> <b>A-20119-50048</b>	WPC'95 CPU PCB Assy.-(USA, Japan) WPC'95 CPU PCB Assy.-(International)
6	A-20796	Speaker Display Assembly
a)	5555-12924-00	Speaker 4Ω, Tweeter 15w
b)	5555-12856-00	Speaker 4Ω, 5-1/4", 25w
c)	5901-12784-00	Dot Matrix Display
d)	5556-13957-00	Ferrite Bead, 2-piece 3/4 Sq.
7	A-14092-7	WPC '95 Mounting Plate Assy.
8	A-20516-50048	WPC '95 Audio Visual PCB Assy.
9	B-10686-1	Knocker Assembly
10	01-6645	Vent Screen
11	04-10508	Backbox
12	01-14480	Shield-Audio Visual

### Backbox Cables:

13	5795-10938-19	Ribbon Cable, 26-pin 19"
14	<b>5795-12653-03</b> <b>04-10396</b>	Ribbon Cable, 34-pin 3"- (USA, Japan) Ribbon Cable, 34-pin w/Ferrite-(Internatio
15	5795-12653-15	Ribbon Cable, 34-pin 15"
16	5795-13434-25	Ribbon Cable 14-pin w/Ferrite

### Ribbon Cables:

H-20477	Logic Power Cable
H-20478	Secondary Cable
H-20479	Dot Matrix Power Cable

## 50048-IN Insert Panel Assembly

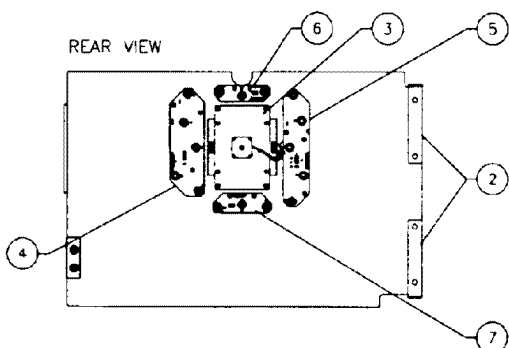
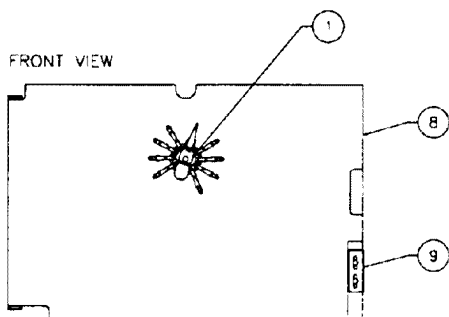

Item	Part Number	Description
1	A-21023	Spider Assembly
2	01-6571	Hinge Mounting Bracket
3	A-21248	Spin Drive Assembly
4	A-21302	5-Lamp PCB Assembly
5	A-21303	5-Lamp PCB Assembly
6	A-21304	3-Lamp PCB Assembly
7	A-21305	3-Lamp PCB Assembly
8	11-50048.1-IN	Insert Panel, Wood
9	01-6655	Insert Latch

*Note: For clarity purposes, only main sub-assemblies are shown.*

# 50048-CAB Cabinet Assembly

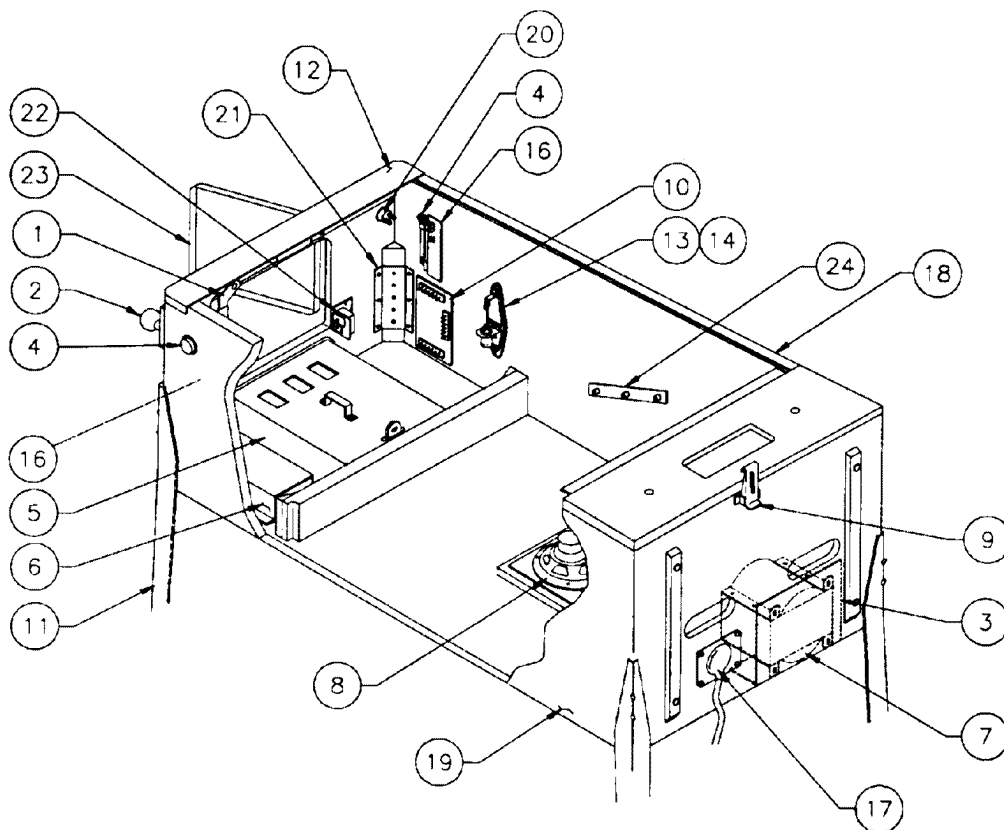

### Miscellaneous Parts (Not Shown)

Item	Part Number	Description
1	A-16773-1	Lever Guide Assembly
2	A-21314	Ball Shooter Assembly
3	01-13936	Drip Plate - Narrow
4	A-16883-4	Flipper Button w/Spring, Red (2)
5	A-20729-5	4-Ball Cashbox Assembly
6	A-20871	Power Interface Assy.
7	5610-14515-00	WPC Transformer
8	5555-12929-00	Speaker, 4Ω, 6", 25w
9	20-9347	Toggle Latch
10	A-20580	Coin Door Interface Board
11	A-19514	Leg Assembly, Chrome (4)
12	D-12615	Front Molding Assembly
13	20-6502-A	Plumb Bob
14	04-10346	Tilt Mechanism Assembly
15	*	Cordset
16	A-17316	Opto Flipper Assembly (2)
17	01-10714	Line Cord Cover
18	A-12359-3	Side Molding Assembly (2)
19	11-1335	Wood Cabinet
20	20-9663-16	Push Button w/Sw., Start (Yellow)
21	01-11400	Leg Plate (4)
22	A-18249-1	Cable & Interlock Switch Assy.
23	09-61000-1	Coin Door-U.S.A.
24	01-11408	Plate Spacer (2)

Part Number	Description
A-17195	Tilt Switch Assy. w/Cable
A-19562.1	Stay Arm Assembly
01-12352	Clip Bracket
01-9011.1-L	Backbox Mtg. Bracket, Left
01-9011.1-R	Backbox Mtg. Bracket, Right
01-6389-1	Cashbox Lock Bracket
08-7028-T	Playfield Glass
08-7377	Leg Leveler Adjuster, 3"
20-6500	Steel Ball, 1-1/16" (6)
01-3535	Rod Mounting Plate

### Cabinet Cables

A-20201	Cable & Jumper Assy., Coin Door
H-17217.1	Plumb/Bob Mech. Protect Cable
H-17837-2	Voltage Program Jumper Cable
H-20599-1.1	WPC '95 Cabinet Cable
H-19601-1	Power Extension Cable
H-20856	Cabinet Switch/Lamp Cable
H-21281	Skull Mounting Cable

\* See Application Chart p.2-31.

# A-20516-50048

## WPC '95 Audio Visual PCB Assembly

Part Number	Designator	Description	Part Number	Designator	Description
4004-01005-06	-	Mach. Screw, 4-40 x 3/8"	5048-13172-00	C78	Cap., 47pf, 50v, 20% Ax.
4404-01119-00	-	Nut 4-40 ESN	5048-13418-00	C4 - C6	Cap., .047m, 50v, 5% Ax.
5010-08774-00	R2, R17, R22, R23, R35, R36, R40, R42, R87	Resistor, 22K $\Omega$ , 1/4w, 5%	5048-13609-00	C9, C12, C15	Cap., 3900pf, 50v, 5% Ax.
5010-08991-00	R20, R46-R48, R50, R72, R76, R77, R80, R107	Resistor, 4.7K $\Omega$ , 1/4w, 5%	5048-13610-00	C8, C10, C11, C13, C14	Cap., 1000pf, 50v, 5% Ax.
5010-09034-00	R21	Resistor, 10K $\Omega$ , 1/4w, 5%	5048-13611-00	C16, C17, C20, C21	Cap., 680pf, 50v, 5% Ax.
5010-09036-00	R19	Resistor, 100 $\Omega$ , 1/4w, 5%	5048-14563-00	C29-C31, C81, C82	Cap., .01 $\mu$ f, 200v, 10% Axial
5010-09134-00	R32-R34	Resistor, 150K $\Omega$ , 1/4w, 5%	5070-09045-00	D19-D22	Diode MR501, 3.0A
5010-09219-00	R1, R3	Resistor, 8.2K $\Omega$ , 1/4w, 5%	5070-09054-00	D4, D6-D17, D23	Diode 1N4004, 1.0A
5010-09416-00	R73, R74, R82, R88, R105, R106	Resistor, 470 $\Omega$ , 1/4w, 5%	5075-12823-00	D1, D18	Zener, 1N4758A 56v, 1w
5010-09807-00	R30, R31, R67-R69, R102	Resistor, 120 $\Omega$ , 1/4w, 5%	5075-12824-00	D3, D5	Zener, 1N4742A 12v, 1w
5010-10171-00	R24	Resistor, 56 $\Omega$ , 1/4w, 5%	5075-12826-00	D2	Zener, 1N4759, 62v, 1w
5010-10258-00	R86	Resistor, 1M $\Omega$ , 1/4w, 5%	5160-08938-00	Q13-Q15	Transistor, 2N4401 NPN
5010-10983-00	R53, R75, R79, R84, R85, R89, R90	Resistor, 1.8K $\Omega$ , 1/4w, 5%	5164-09056-00	Q2, Q3	Transistor, MPSD02 NPN
5010-12832-00	R25, R26, R27, R29	Resistor, 47K $\Omega$ , 1/4w, 5%	5164-12154-00	Q1, Q7	Transistor, MJE15030 NPN
5010-13215-00	R78, R97-R101	Resistor, 200K $\Omega$ , 1/4w, 5%	5194-09055-00	Q4, Q5	Transistor, MPSD52 PNP
5010-13372-00	R91-R96, R103, R104	Resistor, 220 $\Omega$ , 1/8w, 5%	5194-12155-00	Q6	Transistor, MJE15031 PNP
5010-13420-00	R37, R41	Resistor, 680 $\Omega$ , 1/4w, 5%	5250-13302-00	U7	Reg. 78L05T 5v
5010-13517-00	R38, R39	Resistor, 15 $\Omega$ , 1/4w, 5%	5250-13303-00	U8	Reg. 79L05T 5v
5010-13607-00	R4, R5, R7-R15	Resistor, 6.19K $\Omega$ , 1/8w, 1%	5311-12538-00	U4	IC 74HC14 Hex. S-T
5012-14558-00	R44	Resistor, 1.8K $\Omega$ , 5w vertical	5317-12211-00	U12-U14	IC Octal Buffer 74ALS541
5012-14559-00	R43	Resistor, 4.7K $\Omega$ , 5w vertical	5340-12278-00	U25	S/Ram 2064 160NS
5012-14560-00	R28	Resistor, 120 $\Omega$ , 5w vertical	5370-12687-00	U27	IC MC 340640Reset Chp
5013-13661-00	R16	Resistor, 9.09K $\Omega$ , 1/4w, 1%	5349-14351-00	U9-U11	SRAM 8Kx8-35ms, 28pdlp
5013-14456-00	R6, R18	Resistor, 3.32K $\Omega$ , 1/4w, 1%	5370-12730-00	U1, U2	IC Op Amp TL084
5040-14569-00	C35	Cap., 100mf, 25v, Axial	5370-13419-00	U5, U6	IC TDA 2030AV 18w, Audio Amp
5040-09365-00	C38, C39, C43, C44	Cap., 1m, 63v(+50,-10%)Ax.	5371-13299-00	U3	IC Ad-1851 16bit mono
5040-12750-00	C48, C52, C73	Cap., 22m, 35v Radial	5520-14561-00	X2	Crystal 20mHz, parallel 20pf
5040-13098-00	C18, C67, C68	Cap., 4.7 $\mu$ , 35v ( $\pm$ 20%)	5671-14516-00	LED 501	Led-Display Red T 1-3/4
5040-13417-00	C36, C37	Cap., 10000 $\mu$ f, 35v Radial	5700-08985-00	U24	Socket IC 40-pin. 6
5040-14564-00	C28, C42	Cap., 150 $\mu$ f, 160v, 20%Rad.	5700-12047-00	U22	Socket IC 24.3P
5043-08996-00	C2, C3, C19, C22-C24, C26, C32, C34, C45, C46, C49, C50, C53-C66, C69, C72, C74-C76, C79, C80	Cap., 0.1 $\mu$ f, 50v ( $\pm$ 20%) Ax.	5700-12088-00	S2-S7	Socket Dip 32.6P"
5043-10267-00	C47, C51	Cap., 150pf, 100v Cer. Ax.	5705-12638-00	U5, U6	Heatsink 5298B
5048-10992-00	C27	Cap., .0047m, 50v, 10% Ax.	5705-14562-00	Q1, Q6, Q7	Heatsink 10-220 wave sol 287
5048-11028-00	C77	Cap., 22p, 50v, Axial	5733-14528-00	F501, F502, F601, F602	Fuse Holder 5x20mm 10A.
5048-11029-00	C25	Cap., 100p, 50v, 5% Axial	5731-14532-00	F501, F502	Fuse 5x20mm T2.5A., 250V
5048-11030-00	C7	Cap., 470p, 50v, Axial	5731-14840-00	F601, F602	Fuse 5x20mm T0.315A., 250V
5048-11033-00	C1	Cap., .022m, 50v, 10% Ax.	5791-10850-00	J602	Connector, 26-pin Header Str.
5048-12036-00	C40, C41	Cap., .22m, 50v, Axial	5791-10862-04	J504, J505	Connector, 4-pin Header Str.
			5791-10862-07	J606	Connector, 7-pin Header Str.
			5791-10862-08	J604	Connector, 8-pin Header Str.
			5791-10862-11	J605	Connector, 11-pin Header Str.
			5791-12516-00	J601	Connector, 34 hdr 2 x 17. 100
			5791-12827-00	J603	Connector, 14 Hen 7x2 Str.
			5791-13830-10	J607	Connector, 10-pin Str. Sq.
			5010-09534-00	W0, W1, W12-W17, R49	Resistor, 0 $\Omega$ , 0w
			A-5343-50048-S2	S2	E-PROM Assembly
			A-5343-50048-S3	S3	E-PROM Assembly
			A-5343-50048-S4	S4	E-PROM Assembly

# A-20516-50048 WPC '95 Audio Visual PCB Assembly

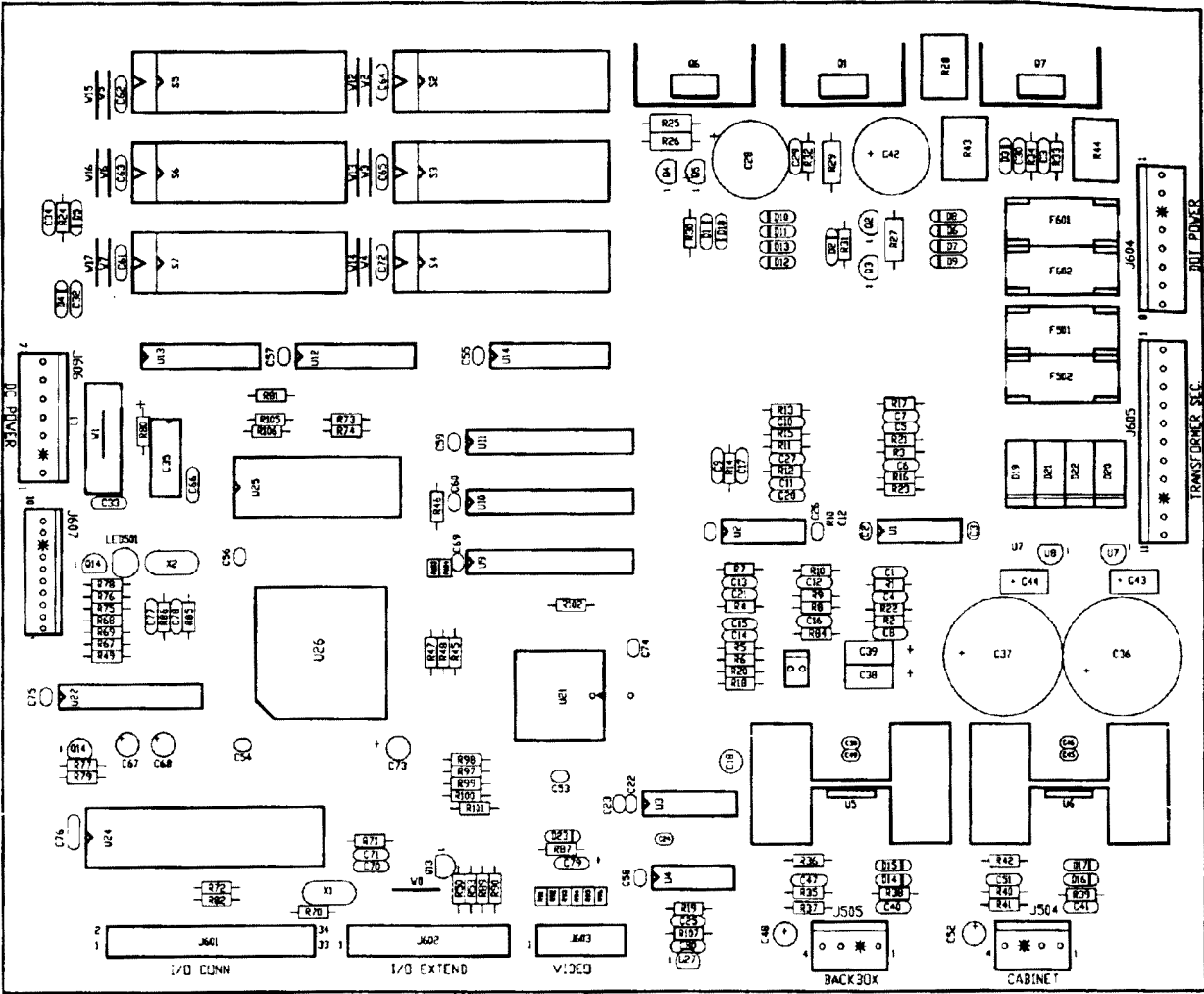

# A-20028

## WPC '95 Power Driver PCB Assembly

Part Number	Designator	Description	Part Number	Designator	Description
5040-14569-00	C1, C40	Capacitor, 100µF, 25v, Ax.	5010-09999-00	R3, R4, R6-R8, R43, R44, R81-R83, R190	Resistor, 2KΩ, 1/4w, 5%
5043-08996-00	C2, C4, C5, C7, C13, C16-C21, C24-C39, C41-C43	Capacitor, 0.1m, 50v (±20%) Ax.	5010-09224-00	R5, R14 - R17	Resistor, 270Ω, 1/4w, 5%
5040-13417-00	C8 - C12	Capacitor, 10000µf, 35v Radial	5012-12632-00	R9	Resistor, 12Ω, 10w, 5%
5048-11031-00	C14, C15	Capacitor, .001m, 50v, 10% Ax.	5010-09324-00	R10	Resistor, 27KΩ, 1/4w, 5%
5040-09537-00	C22, C23	Capacitor, 100µ, 100v (±20%) Radial	5010-09358-00	R11, R157, R159, R161, R163, R165, R167, R169, R171, R216-R224	Resistor, 1KΩ, 1/4w, 5%
5070-09054-00	D1, D2, D23, D24, D33 - D100, D103	Diode 1N4004 1.0A.	5010-09036-00	R247	Resistor, 100Ω, 1/4w, 5%
5070-14526-00	D3-D22, D25-D32	Diode P600G 6A 400 PIV	5010-09034-00	R12, R13, R189, R208-R215, R248	Resistor, 10KΩ, 1/4w, 5%
5070-08919-00	D101, D102	Diode, 1N4148 150mA.	5010-08992-00	R18, R21, R24, R192, R194, R196, R198, R200, R202, R204, R206	Resistor, 560Ω, 1/4w, 5%
5731-14531-00	F101	Fuse 5 x 20mm T.63A., 250V	5010-08991-00	R19, R22, R25, R28, R30, R32, R34, R50, R52, R54, R56, R58, R60, R62, R64, R84, R86, R88, R90, R92, R94, R96, R98, R116, R119, R122, R125, R128, R131, R134, R137, R246	Resistor, 4.7KΩ, 1/4w, 5%
5731-14530-00	F102-F105, F107, F109-F118	Fuse 5 x 20mm T 4A, 250V	5010-11079-00	R20, R23, R26, R254-R256	Resistor, 51Ω, 1/4w, 5%
5731-14046-00	F106	Fuse S-B, 5A, 5x20mm	5010-09416-00	R27, R29, R31, R33, R45-R49, R51, R53, R55, R57, R59, R61, R63, R85, R87, R89, R91, R93, R95, R97, R99, R117, R120, R123, R126, R129, R132, R135, R138, R156, R158, R160, R162, R164, R166, R168, R170, R245, R250-R253, R257	Resistor, 470Ω, 1/4w, 5%
5731-14529-00	F108	Fuse 5 x 20mm T 6.3A, 250V	5010-08993-00	R35, R37, R39, R41, R65-R72, R100-R107, R140-R147	Resistor, 68Ω, 1/4w, 5%
5733-14528-00	F101-F118	Fuse Holder 5 x 20mm10A	5010-08997-00	R36, R38, R40, R42, R73-R80, R108, R109, R110-R115, R118, R121, R124, R127, R130, R133, R136, R139	Resistor, 2.7kΩ, 1/4w, 5%
5705-14724-00	Q1	Heat Sink TO-3 5.1DEG/W	5010-09361-00	R148-R155, R184-R187	Resistor, 220Ω, 1/4w, 5%
5701-09652-00	Q1	Thermal Pad TO-3	5011-12956-00	R172, R173, R178-R183	Resistor, 2.7KΩ, 1/4w, 5%
4406-01128-00	Q1	Nut 6-32 KEPS	5010-10171-00	R174-R177, R241-R244	Resistor, 56Ω, 1/4w, 5%
4006-01005-06	Q1	Mach. Screw, 6-32 x 3/8"	5010-14711-00	R188	Resistor, 10KΩ, 1/4w, 5%
5705-14562-00	Q2	Heat Sink 10-220 Wave Sol 287	5010-09314-00	R191, R193, R195, R197, R199, R201, R203, R205	Resistor, 1.2kΩ, 1/4w, 5%
4004-01005-06	Q2-Q5	Mach. Screw, 4-40 x 3/8"	5010-09086-00	R207	Resistor, 6.8kΩ, 1/4w, 5%
4404-01119-00	Q2-Q5	Nut 4-40 ESN	5010-12427-00	R225, R228, R231, R234, R237-R240	Resistor, .22kΩ, 1/4w, 5%
5705-12638-00	Q3-Q5	Heat Sink 5298B	5010-08998-00	R226, R227, R229, R230, R232, R233, R235, R236	Resistor, 2.2kΩ, 1/4w, 5%
5791-10862-07	J101, J129	Connector, 7-pin Header Str.	5010-13517-00	R249	Resistor, 150Ω, 1/4w, 5%
5791-12516-00	J102	Connector, 34 Hdr 2x17	5019-10143-00	SRI	SiP RES 470 x 9R
5791-10862-12	J103	Connector, 12-pin Header Str.	5824-09248-00	TP100-TP107	Test Point #1502-1
5791-10862-03	J104, J122, J132, J135	Connector, 3-pin Header Str.	5370-12272-00	U1, U16, U17	I.C. LM339 Quad Comp
5791-10862-11	J105, J106	Connector, 11-pin Header Str.	5281-09486-00	U2, U4-U8, U10	I.C. 74LS374 8dttf
5791-10862-05	J107, J108, J114, J115, J117, J118, J127, J130, J131, J134, J139	Connector, 5-pin Header Str.	5162-12422-00	U3, U11	Trans uln 2803 Oc-drl
5791-10862-09	J109, J112, J113, J116, J119, J121, J123, J128	Connector, 9-pin Header Str.	5281-10182-00	U9	I.C. 74LS240 Vdrrr
5791-10862-13	J111, J120	Connector, 13-pin Header Str.	5281-09487-00	U12 - U15	I.C. 74LS74 Dual d t/f
5791-13830-09	J124-J126	Connector, 9-pin Header Str.	5791-13830-05	J110	Connector, 5-pin Header
5791-10862-06	J133	Connector, 6-pin Header Str.			
5791-10862-04	J136-J138, J140, J141	Connector, 4-pin Header Str.			
5671-14516-00	LED100-LED105	LED Dspl Red T-1			
5250-14527-00	Q1	Regulator Voltage LM317K			
5460-12423-00	Q2	I.C. LM7812			
5131-12725-00	Q3-Q5	Triac BT138E			
5194-09055-00	Q6-Q12, Q17-Q24, Q33-Q40, Q49-Q56, Q109	Transistor, MPSD52 PNP			
5162-12635-00	Q13-Q16, Q25-Q32, Q41-Q48, Q57-Q64, Q82, Q83, Q85, Q86, Q88, Q89, Q91, Q92, Q101-Q108	Transistor, TIP102			
5191-12179-00	Q65-Q72, Q81, Q84, Q87, Q90	Transistor, TIP36C			
5190-09016-00	Q73 - Q80	Transistor, 2N4403 PNP			
5192-12428-00	Q93 - Q100	Transistor, TIP107			
5160-10269-00	Q110	Transistor, 2N3904			
5013-14535-00	R1	Resistor, 750Ω, 1/4w, 1%			
5013-14534-00	R2	Resistor, 243Ω, 1/4w, 1%			

# A-20028 WPC '95 Power Driver PCB Assembly

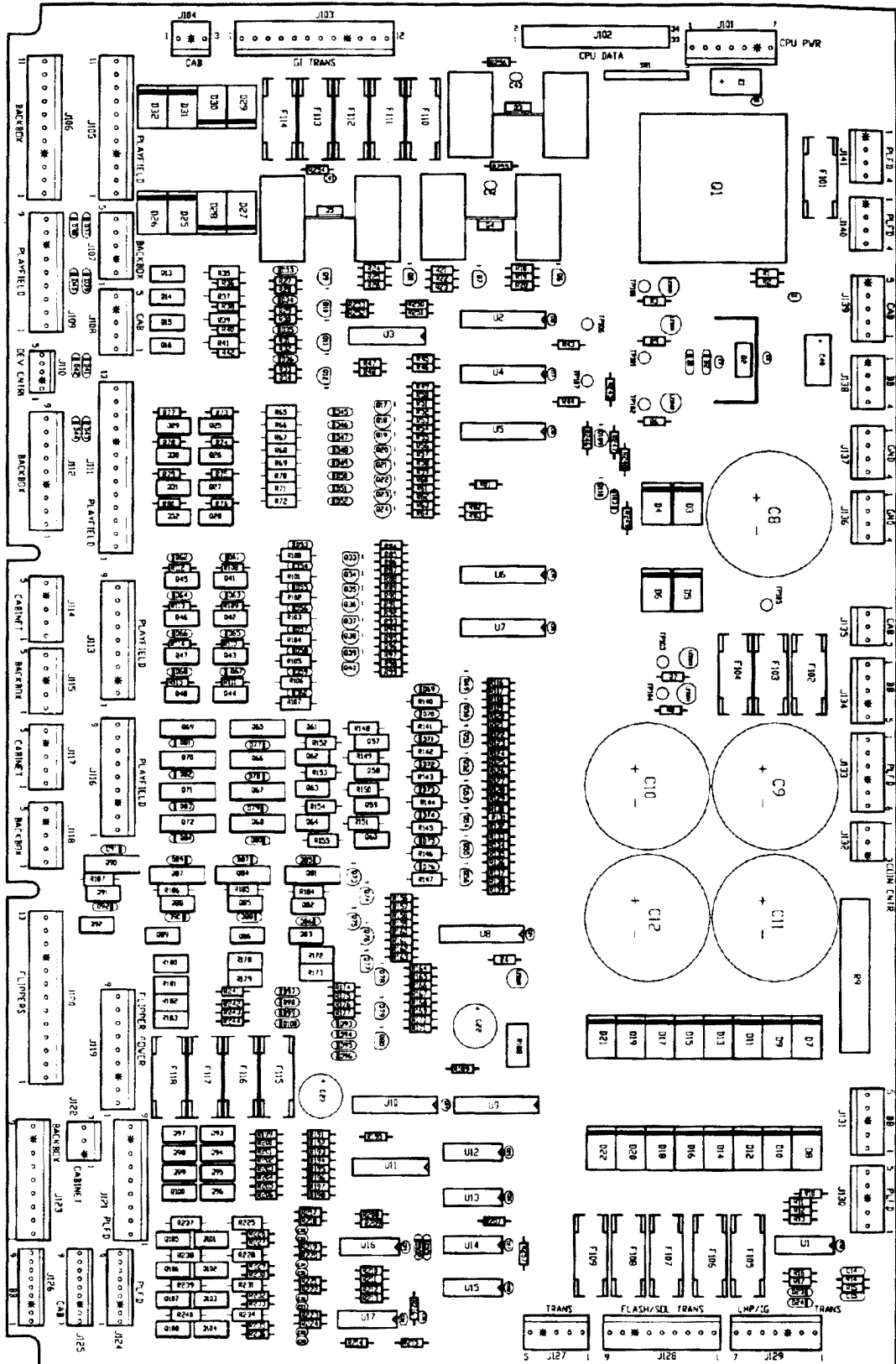



# A-21377-50048

## WPC '95 CPU PCB Assembly

Part Number	Designator	Description
A-15814	B1	Battery Holder
5048-11033-00	C1, C42	Capacitor, .022m, 50v, 10% Axial
5048-11030-00	C3-C26, C34-C41	Capacitor, 470p, 50v, Axial
5043-09030-00	C27	Capacitor, .047m, 50v (±20%) Axial
5048-13375-00	C28	Capacitor, 100p, 50v (10%) Axial
5048-11028-00	C29, C30, C34, C44	Capacitor, 22p, 50v Axial
5040-14569-00	C31, C77	Capacitor, 100mf, 25v Axial
5048-11031-00	C32	Capacitor, .001m, 50v, 10% Axial
5043-08996-00	C45-C70, C74-C76	Capacitor, 0.1m, 50v (±20%) Axial
5040-13098-00	C73	Capacitor, 4.7µF, @35v (±20%)
5645-09025-00	DIPSW1	Switch Dip 8 Pos
5070-09266-00	D1, D25	Diode 1N5817 1.0A.
5070-08919-00	D2-D24, D26, D27	Diode 1N4148 150ma
5700-10176-00	G10A	Socket Dip 28.6
5700-12088-00	G11	Socket Dip 32.6p"
5700-08985-00	U4	Socket I C 40PIN .6
5700-12424-00	U9	socket 84 PIN PL CC
5700-10389-00	U20	Socket I C 18 PIN 3"
5791-10650-00	J201	26H STR SQ. .100
5791-12516-00	J211, J202	34 HDR 2x17 .100
5791-13830-12	J205	12H STR SQ PIN .100 Solid Tab
5791-13830-09	J206, J207, J209	9H STR SQ PIN .100 Solid Tab
5791-13830-14	J208	14H STR SQ PIN .100 Solid Tab
5791-10862-07	J210	7H STR SQ PIN .156
5791-13830-13	J212	13H STR SQ PIN .100 Solid Tab
5671-14516-00	LED201, LED202, LED203	LED DSPL RED T-1 3/4
5160-10269-00	Q1	Trans 2N3904 NPN
5019-09669-00	RP1	SIP 1K 9R 10 5%
5010-09358-00	R1, R2, R3, R4, R9, R10, R11, R23, R24, R25, R26, R43, R44, R45, R46, R47, R48, R49, R50, R51, R52, R53, R54, R55, R56, R57, R58, R59, R60, R61, R62, R63, R64, R65, R66, R67, R68, R69, R70, R71, R72, R73, R74, R75, R76, R77, R78, R79, R80, R81, R82, R83, R84, R93, R95, R96, R97, R99, R100, R101, R102, R103, R104, R105, R106, R107, R108, R109, R110, R111, R112, R113, R114, R117	RES 1K 1/4w 5%
5010-09416-00	R5, R6, R7, R8, R12, R13, R87, R88, R89	RES 470 1/4w 5%
5010-09034-00	R14, R15, R16, R17, R18, R19, R20, R21, R22, R27, R28, R29, R30, R31, R32, R33, R34, R35, R36, R37, R38, R39, R40, R41, R42, R86, R90, R94, R98	RES 10K 1/4w 5%
5010-12104-00	R91	RES 22M 1/4w 5%
5010-10989-00	R92	RES 470K 1/4w 5%
5010-09187-00	R118, RR119, R120, R121, R122, R123, R128, R130	RES 150 1/4w 5%
5010-09534-00	W3, W4, W7, R124, R125	RES 0, 0w
5010-10258-00	R126	RES 1M 1/4w 5%
5010-09040-00	R127	RES 33 1/4w 5%
5281-09867-00	U1, U2	I C 74LS244 OCT BUF
5281-09308-00	U3	I C 74LS245 TRNC
5281-09851-00	U5	I C 74LS14 SMT/TRG
5315-12031-00	U7	I C 74HCT244
5340-13062-00	U8	IC RAM 32K x8 Static Cmos 100ns
5370-12687-00	U10	I C MC 34064 Reset CHP
5281-10182-00	U11, U12, U13, U15	I C 74LS240 L/DRVR
5311-14068-00	U14, U24	I C 74HC574 OCTAL D-L atch
5370-12272-00	U16, U17, U18, U19, U25, U26	I C LM339 Quad Comp
5284-12651-00	U21	I C 4584 Hex Schmitt
5311-14554-00	U23	U I C 74HC237 3 to 8 NON I NV DE
5281-09247-00	U27	I C 74LS02 Quad Nor
5520-12084-00	X1	Crystal 32. 768 KHZ
5520-14761-00	X2	XTL 8MHz Anti-Res Parallel Cut

# A-21377-50048 WPC '95 CPU PCB Assembly

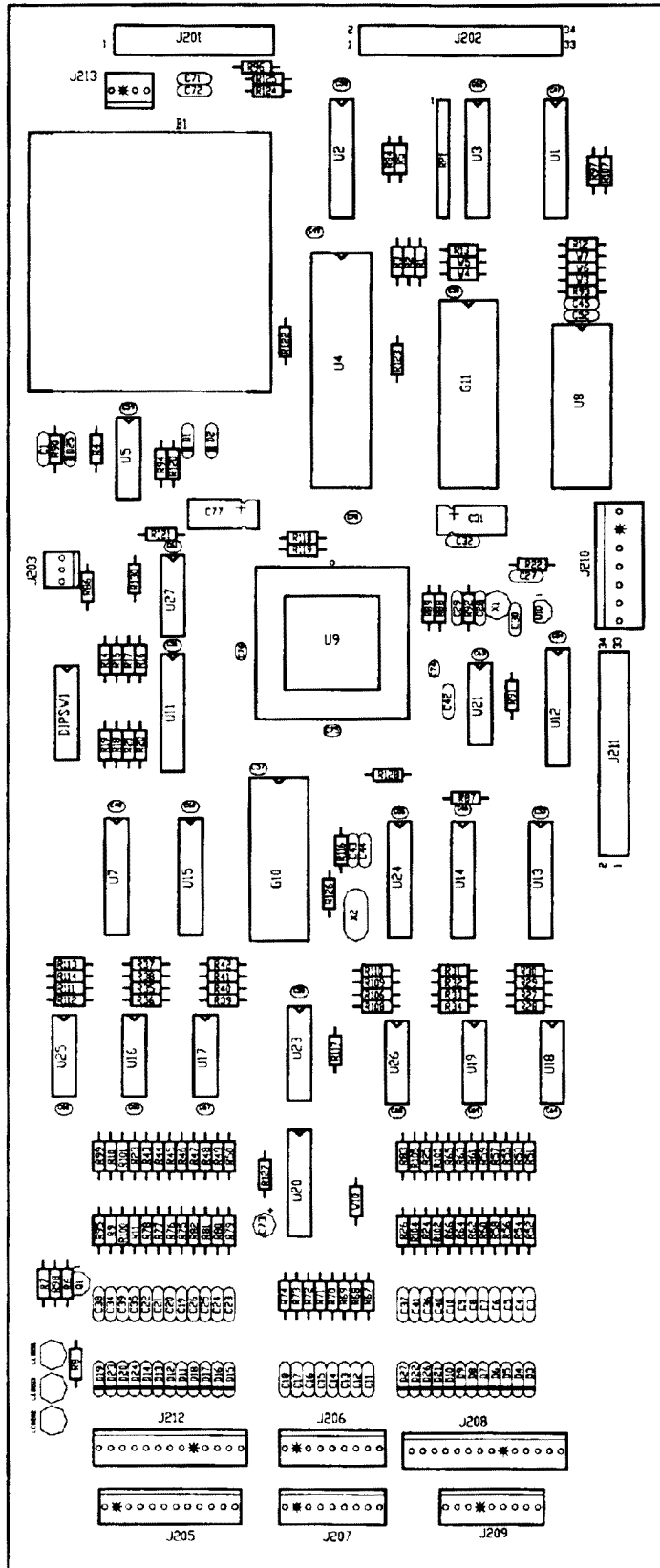

# A-20119-50048

## WPC '95 CPU PCB Assembly

Part Number	Designator	Description
A-15814	B1	Battery Holder
5048-11033-00	C1, C42	Cap., .022 $\mu$ , 50v, 10% Ax.
5048-11030-00	C3-C26, C34-C41	Cap., 470p, 50v Axial
5043-09030-00	C27	Cap., .047m, 50v ( $\pm$ 20%) Ax.
5048-13375-00	C28	Cap., 100p, 50v, 10% Axial
5048-11028-00	C29, C30, C43, C44	Cap., 22p, 50v Axial
5040-14569-00	C31	Cap., 100 $\mu$ , 25v, Axial
5048-11031-00	C32	Cap., .001 $\mu$ , 50v, Axial
5043-08996-00	C45 - C70	Cap., 0.1 $\mu$ , 50v ( $\pm$ 20%) Ax.
5040-13098-00	C73	Cap., 4.7 $\mu$ F, 35v ( $\pm$ 20%)
5645-09025-00	DIPSW1	Switch Dip 8-Position
5070-09266-00	D1, D25, D28	Diode 1N5817 1.0A.
5070-08919-00	D2 - D24, D26, D27	Diode 1N4148 150mA.
5700-10176-00	G10	Socket Dip 28.6
5700-12088-00	G11	Socket Dip 32.6p"
5700-08985-00	U4	IC Socket 40-pin
5700-12424-00	U9	Socket 84-pin
5700-10389-00	U20	IC Socket 18-pin 3"
5791-10850-00	J201	Connector, 26-pin Header
5791-12516-00	J202, J211	Connector, 34-pin Hdr. 2x17
5791-13830-12	J205	Connector, 12-pin Header Str.
5791-13830-09	J206, J207, J209	Connector, 9-pin Header
5791-13830-14	J208	Connector, 14-pin Header
5791-10862-07	J210	Connector, 7-pin Header
5791-13830-13	J212	Connector, 13-pin Header
5671-14516-00	LED201 - LED203	LED Dspl. Red T-1-3/4
5160-10269-00	Q1	Transistor, 2N3904 NPN
5019-09669-00	RP1	SIP 4.7K, 9R, 10 (5%)
5010-09358-00	R1-R4, R9-R11, R23-R26, R43-R84, R93, R95-R97, R99-R114, R117	Resistor, 1k $\Omega$ , 1/4W, 5%
5010-08774-00	R129	Resistor, 22K $\Omega$ , 1/4w, 5%
5010-09416-00	R5-R8, R12, R13, R87-R89	Resistor, 470 $\Omega$ , 1/4w, 5%
5010-09034-00	R14-R22, R27-R42, R86, R90, R94, R98	Resistor, 10K $\Omega$ , 1/4w, 5%
5010-12104-00	R91	Resistor, 22M, 1/4w, 5%
5010-10989-00	R92	Resistor, 470K $\Omega$ , 1/4w, 5%
5010-09187-00	R118 - R123, R128	Resistor, 150 $\Omega$ , 1/4w, 5%
5010-09040-00	R127	Resistor, 33 $\Omega$ , 1/4w, 5%
5010-09534-00	W3, W4, W7, R124, R125	Resistor, 0 $\Omega$
5010-10258-00	R126	Resistor, 1M, 5% 1/4w
5281-09867-00	U1, U2, U7	I.C. 74HCT244
5281-09851-00	U5	I.C. 74LS14 SMT/TRG
5281-09308-00	U3	IC 74LS245 Trnc
5340-13062-00	U8	IC RAM 32k x 8 Static
5370-12687-00	U10	I.C. MC 34064 Reset Chp.
5281-10182-00	U11-U13, U15	I.C. 74LS240 V/dvr
5311-14068-00	U14, U24	I.C. 74HC574 Octal d-latch
5370-12272-00	U16-U19, U25, U26	I.C. LM339 Quad Comp.
5284-12651-00	U21	I.C. 4584 Hex Schmitt
5311-14554-00	U23	I.C. 74HC237 3 to 8 non inv
5281-09743-00	U27	I.C. 74LS08 Quad.
5520-12084-00	X1	Crystal 32.768KHz
5520-14761-00	X2	Xtal-8M Anti Res Parallel Cut
A-5400-50048-1	G10	PIC16C57 Assembly
5880-09022-00	B1	Battery 1.5v AA Alkaline
5400-10320-00	U4	I.C. MPU68B09E
5410-12426-00	U9	I.C. WPC-89 ASIC
5162-12422-00	U20	Trans uln 2803 Oc-Drf
A-5343-50048-1	G11	Game ROM Assembly

# A-20119-50048 WPC '95 CPU PCB Assembly

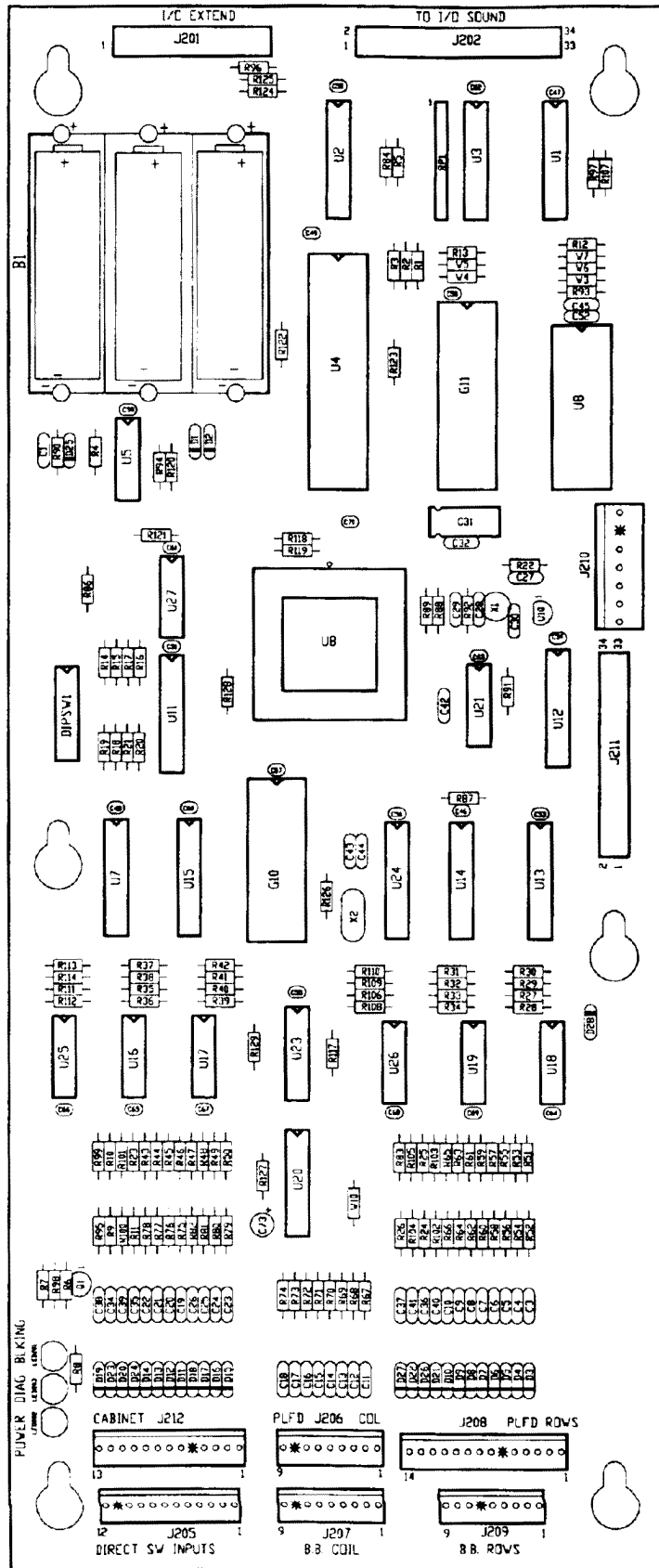

# A-20580 Coin Interface PCB Assembly

*(This board does not contain optional items such as the coin counter and printer interface.)*

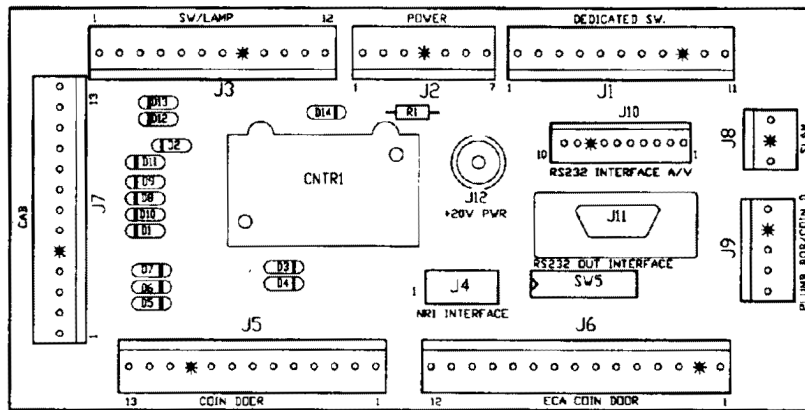

Part Number	Designator	Description
5070-09054-00	D1-D14	Diode 1N4004 1.0A.
5791-10862-11	J1	Connector, 11-pin Header Str. Sq.
5791-10862-07	J2	Connector, 7-pin Header Str. Sq.
5791-10862-12	J3	Connector, 12-pin Header Str. Sq.
5791-11000-10	J4	Connector, 10-pin Header Str. Sq.
5791-10862-13	J5, J7	Connector, 13-pin Header Str. Sq.
5791-10862-15	J6	Connector, 15-pin Header Str. Sq.
5791-10862-03	J8	Connector, 3-pin Header Str. Sq.
5791-10862-05	J9	Connector, 5-pin Header Str. Sq.
5791-12462-10	J10	Connector, 10-pin Header Str. Sq.
5010-13517-00	R1	Resistor, 15Ω, 1/4w, 5%
5645-09025-00	SW5	Switch DIP 8 Pos.

# A-17316 Flipper Opto PCB Assembly

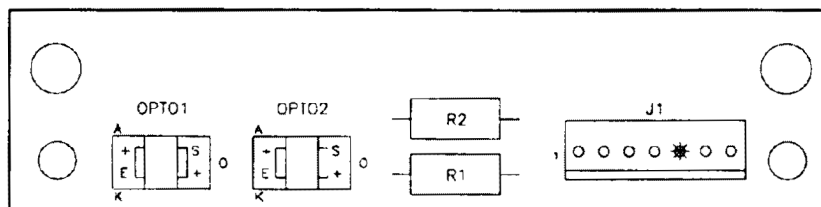

Part Number	Designator	Description
A-20207.1	-	Flipper Opto Switch PCB
5010-09061-00	R1, R2	Resistor, 680Ω, 1/2w, 5%
5490-14575-00	OPTO1, OPTO2	IC Opto Integ Schmitt 10mA.
5791-13830-07	J1	Connector, 7-pin Header Solid Sq.
03-9001.1	-	Interrupter Flip-Opto
01-14348	-	Flipper Switch Spring

## A-18617-1 Trough IR LED PCB Assembly

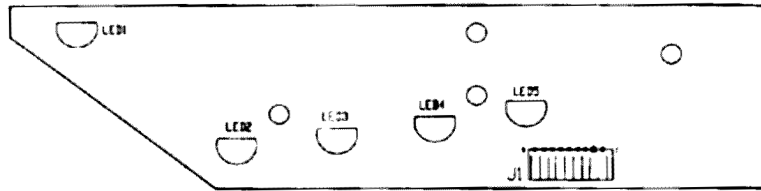

Part Number	Designator	Description
5671-12731-00	LED1 - LED5	Infra Red Diode
5791-12622-09	J1	Connector, 9-pin Header Sq.

## A-18618-1 Trough IR Photo Transistor PCB Assembly

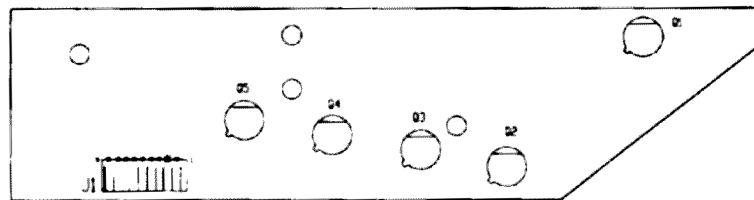

Part Number	Designator	Description
5671-14114-00	Q1 - Q5	Infra Red Photo Transistor
5791-12622-09	J1	Connector, 9-pin Header Sq.

## A-21379.1 Crate LEDS PCB Assembly

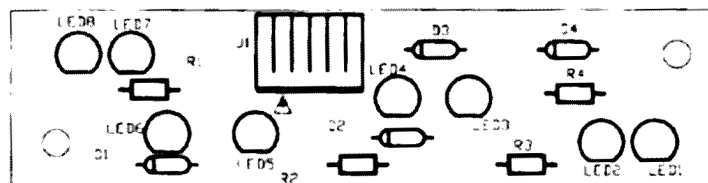

Part Number	Designator	Description
5671-09019-00	LED1-LED8	LED Display RED
5070-09054-00	D1-D4	Diode 1N4004 1.0A.
5791-12622-06	J1	Connector, 6-pin Header
5010-09036-00	R1-R4	Resistor, 100Ω, ¼ w

# A-16998.2

## 16-Opto PCB Assembly

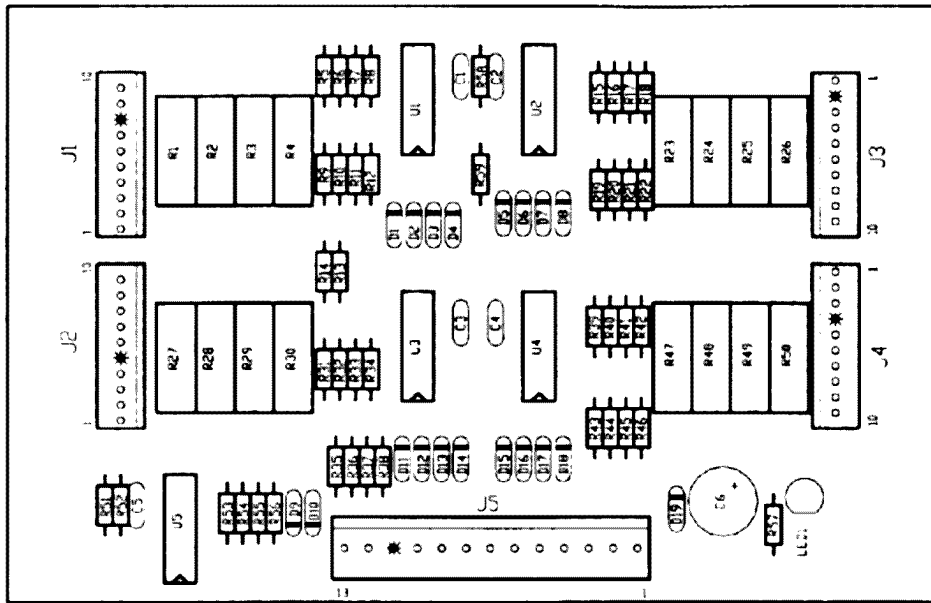

Part Number	Designator	Description
5043-08996-00	C1 - C5	Cap., 0.1m, 50v ( $\pm 20\%$ ) Ax.
5040-13102-00	C6	Cap., 470 $\mu$ f, @ 35v ( $\pm 20\%$ )
5070-09054-00	D1 - D19	Diode 1N4004 1.0A.
5791-13830-10	J1 - J4	Connector, 10-pin Header
5791-10862-13	J5	Connector, 13-pin Header
5671-14516-00	LED1	LED Display Red T-1 $\frac{3}{4}$
5010-12928-00	R1-R4, R23-R30, R47-R50	Resistor, 270 $\Omega$ , 2w, 5%
5010-09999-00	R5-R12, R15-R22, R31-R46, R57	Resistor, 2K $\Omega$ , $\frac{1}{4}$ , 5%
5010-08774-00	R13, R14, R51, R53, R55	Resistor, 22K $\Omega$ , $\frac{1}{4}$ w, 5%
5010-09162-00	R52, R54, R56, R58, R59	Resistor, 100K $\Omega$ , $\frac{1}{4}$ w, 5%
5370-12272-00	U1 - U5	IC LM339 Quad Comp

# A-20781

## 16-LED Skull Driver PCB Assembly

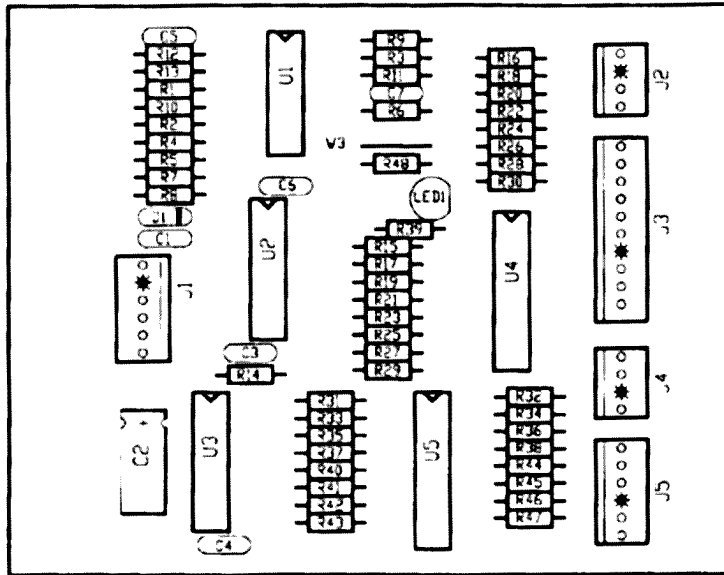

Part Number	Designator	Description
5043-08996-00	C1, C3, C4, C6, C7	Capacitor, 0.1 $\mu$ , 50v ( $\pm$ 20%) Ax.
5040-09343-00	C2	Capacitor, 10 $\mu$ , 20v ( $\pm$ 20%) Ax.
5048-10994-00	C5	Capacitor, 0.33 $\mu$ fd, 50v ( $\pm$ 20%) Ax.
5070-09054-00	D1	Diode 1N4004 1.0A.
5791-13830-06	J1, J5	Connector, 6-pin Header
5791-13830-04	J2, J4	Connector, 4-pin Header
5791-13830-10	J3	Connector, 10-pin Header
5671-14516-00	LED1	LED Display Red
5010-09358-00	R1, R2, R4, R5, R7, R8, R10, R48	Resistor, 1K $\Omega$ , 1/4w, 5%
5010-09034-00	R3, R6, R9, R12, R13, R14	Resistor, 10K $\Omega$ , 1/4w, 5%
5010-08774-00	R11	Resistor, 22K $\Omega$ , 1/4w, 5%
5010-08998-00	R15, R17, R19, R21, R23, R25, R27, R29, R31, R33, R35, R37, R40-R43	Resistor, 2.2K $\Omega$ , 1/4w, 5%
5010-09416-00	R16, R18, R20, R22, R24, R26, R28, R30, R32, R34, R36, R38, R39, R44-R47	Resistor, 470 $\Omega$ , 1/4w, 5%
5370-12272-00	U1	IC LM339 Quad Comp
5310-14760-00	U2, U3	IC 4094 Parallel Out Shift Reg.
5162-12422-00	U4, U5	Trans Uln 2803 Oc-Drl
5010-09534-00	W2	Resistor, 0 $\Omega$ , 0w



## A-18543.1-2 Generic Eddy Sensor PCB Assembly

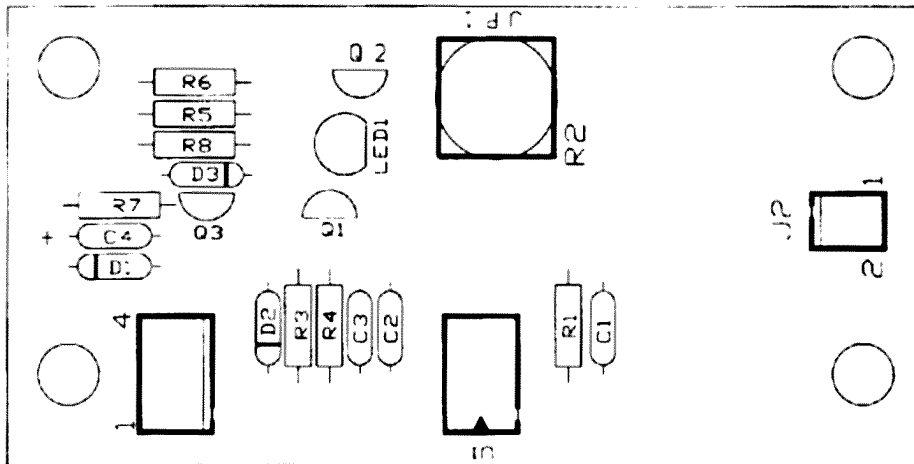

Part Number	Designator	Description
5370-13452-00	U1	IC Proximity Sensor
5190-10270-00	Q2	Trans 2N3906 PNP
5160-10269-00	Q1, Q3	Trans 2N3904 NPN
5010-08992-00	R4	Resistor, 560Ω, ¼w, 5%
5010-09807-00	R3	Resistor, 120Ω, ¼w, 5%
5010-09034-00	R7	Resistor, 10KΩ, ¼w, 5%
5010-09999-00	R1, R5, R6, R8	Resistor, 2KΩ, ¼w, 5%
5671-13732-00	LED1	Display LED Red
5070-08919-00	D1 - D3	Diode 1N4148 150mA
5791-13830-04	J1	Connector, 4-pin Header
5791-13830-02	J2	Connector, 2-pin Header
5041-09031-00	C4	Capacitor, 1M, 25v (±20%) Ax.
5014-10261-00	R2	Pot 10K, ¼w (±20%)
5043-10267-00	C2	Capacitor, 150pF 100v, Ceramic Axial
5043-09065-00	C1	Capacitor, 470p 50V (±20%)

# D-12046 Stepper Motor Sub-Assembly

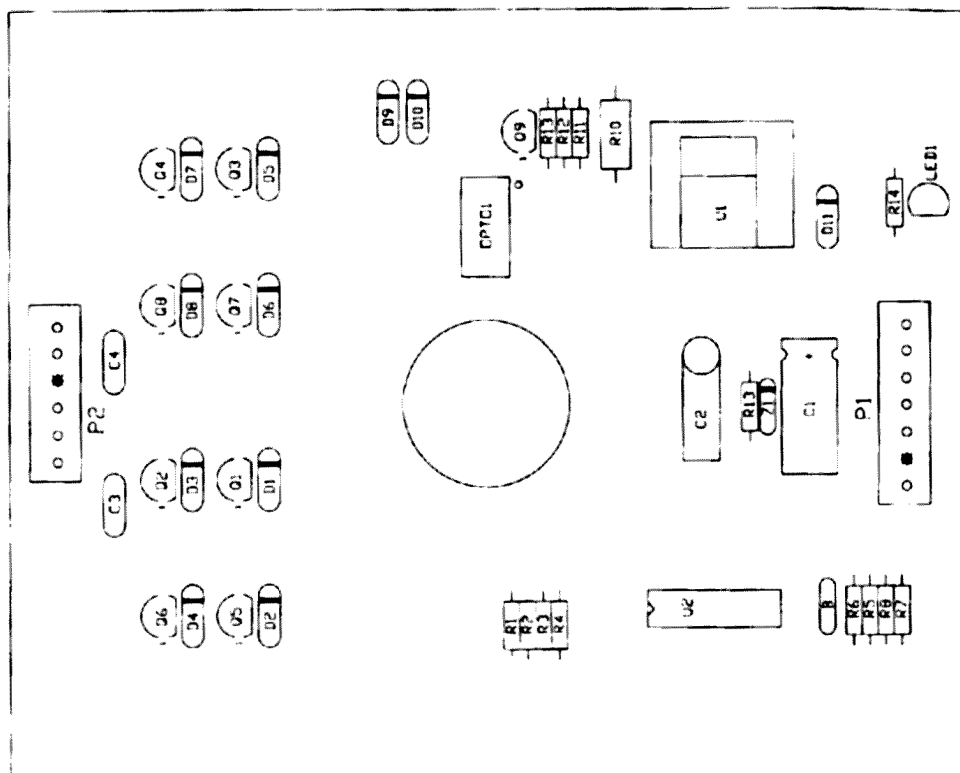

Part Number	Designator	Description
5043-08980-00	C3, C4, B	Capacitor, 0.01 $\mu$ , 50v (+80, -20%) Ax.
5040-12298-00	C1	Capacitor, 100M, 40v (-10, +50) Ax.
5040-09365-00	C2	Capacitor, 1M, 63v (+50, -10) Ax.
5070-09054-00	D1-D10	Diode 1N4004 1.0A.
5070-08919-00	D11	Diode 1N4148 150MA
5075-09059-00	D12	Zener 1N5990 3.9v 1/2w
5791-10871-07	P1	Connector, 7-pin Header
5791-10871-06	P2	Connector, 6-pin Header
5671-13732-00	LED1	Display LED Red
5160-08938-00	Q1-Q4	Trans 2N4401 NPN
5190-09016-00	Q5-Q8	Trans 2N4403 PNP
5190-10270-00	Q9	Trans 2N3906 PNP
5010-08998-00	R1-R4	Resistor, 2.2K $\Omega$ , 1/4w, 5%
5010-09034-00	R5, R6, R9	Resistor, 10K $\Omega$ , 5%, 1/4w
5010-08991-00	R7, R8	Resistor, 4.7K $\Omega$ , 5%, 1/4w
5010-08930-00	R10	Resistor, 470 $\Omega$ , 5%, 1/4w
5010-09324-00	R11	Resistor, 27K $\Omega$ , 5%, 1/4w
5010-09356-00	R12	Resistor, 820 $\Omega$ , 5%, 1/4w
5010-09162-00	R13	Resistor, 100K $\Omega$ , 5%, 1/4w
5010-09999-00	R14	Resistor, 2K $\Omega$ , 5%, 1/4w
5250-09157-00	U1	Reg 7805 1.0A. 5v
5370-12272-00	U2	IC LM339 Quad Comp
5490-10159-00	OPTO1	Opto Inter MDL L/G
5705-09042-00	U1	Heat Sink
20-9229	U1	Heat Sink Compound
4406-01128-00	U1	Hex Nut #6-32 KEPS
4006-01003-06	U1	Screw #6-32 3/8 P-PH-S

# A-14876-R-3 Flipper Assembly

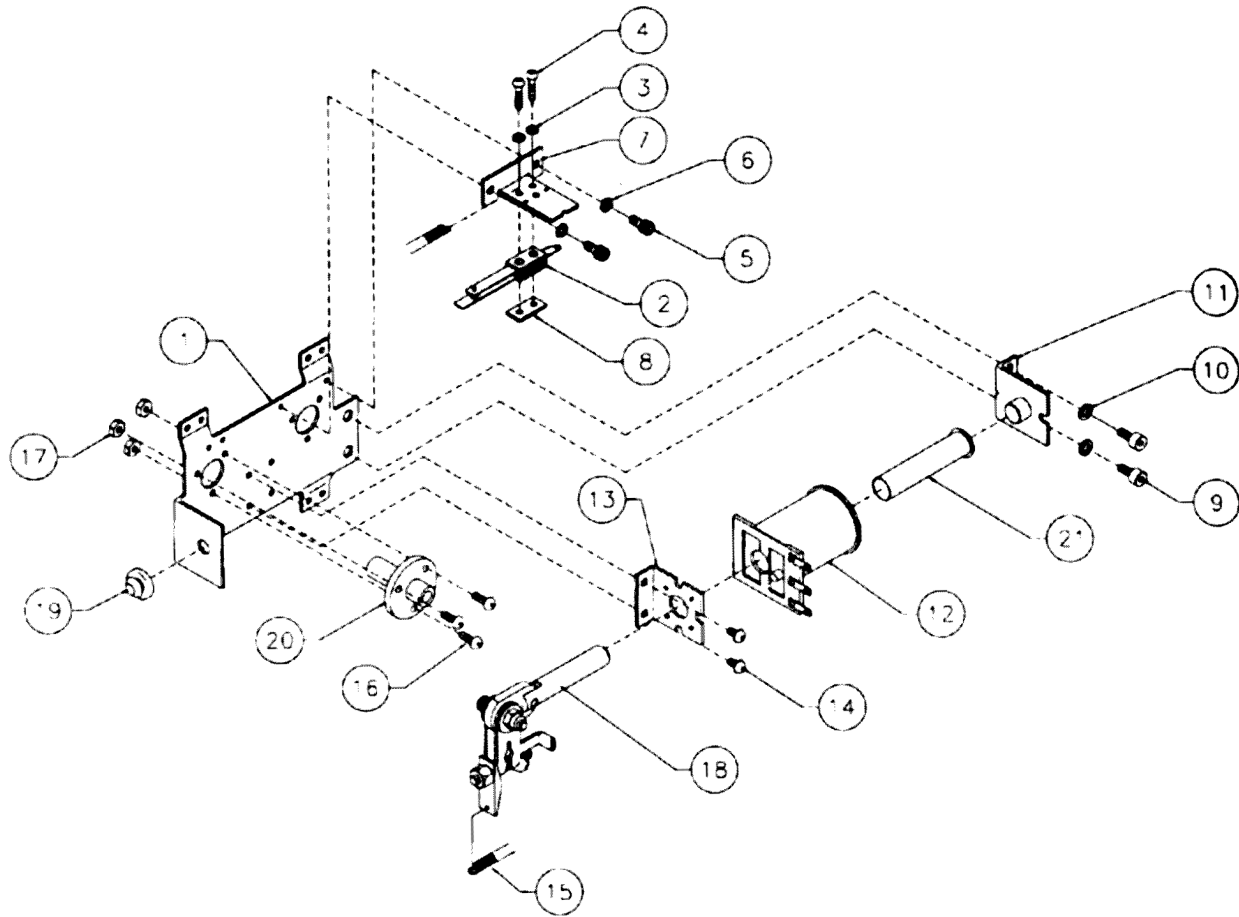

Item	Part Number	Description	Item	Part Number	Description
1	A-14877-R	Flipper Base Assembly, Right	18	A-15848-R	Crank Link Assembly, Right
2	SW-1A-194	Switch Assembly	a)	A-17050-R	Flipper Crank Assembly, Right
3	4701-00002-00	Lock Washer #6 Split	b)	A-15847	Flipper Link Assembly
4	4105-01019-10	Sh. Metal Screw, #5 x 5/8"	c)	02-4676	Link Spacer Bushing
5	4008-01079-05	Mach. Screw, 8-32 x 5/16"	d)	4010-01086-14	Cap Screw, 10-32 x 7/8"
6	4701-00003-00	Lock Washer #8 Split	e)	4700-00023-00	Flat Washer, 5/8 x 13/64 x 16ga.
7	01-9375	Switch Mounting Bracket	f)	4701-00004-00	Lock Washer #10 Split
8	20-6516	Speednut, Tinnerman	g)	4410-01132-00	Nut 10-32 ESN
9	4010-01066-06	Cap Screw, 10-32 x 3/8"	19	23-6577	Bumper Plug, 5/8"
10	4701-00004-00	Lock Washer #10 Split	20	03-7568	Flipper Bushing
11	A-12390	Flipper Stop Assembly	21	03-7066-5	Coil Tubing
12	FL-11629	Flipper Coil, Blue	<b>Associated Parts:</b>		
13	01-7695-1	Solenoid Bracket	(Not Shown)		
14	4006-01017-04	Mach. Screw, 6-32 x 1/4"	21	23-6695	Flipper Ring
15	10-364	Spring	22	20-10343	Flipper & Shaft
16	4006-01005-06	Mach. Screw, 6-32 x 3/8"			
17	4406-01117-00	Nut 6-32 Hex.			

### Flipper Notes...

1. Each Flipper Assembly is mounted beneath the playfield, in conjunction with the Plastic Flipper & Shaft, and Flipper Rubber on the upper side of the playfield.
2. With the flipper, in the non-activated position, the E.O.S. Switch contacts must have a gap of .062 ( $\pm$  .015) inch. When flipper is activated switch must close.
3. Any adjustment of the E.O.S. switch must be made at a minimum distance of 0.25 inch from the switch body.
4. Longer blade of E.O.S. switch must be made straight. Gap adjustment is done by adjusting shorter blade.
5. All moving elements of the assembly must operate freely without any evidence of binding.
6. Apply Loctite™ 245 when reattaching screws to the Flipper Stop Assembly, the Solenoid Bracket, and the Flipper Bushing.

# A-15849-L-2 Flipper Assembly

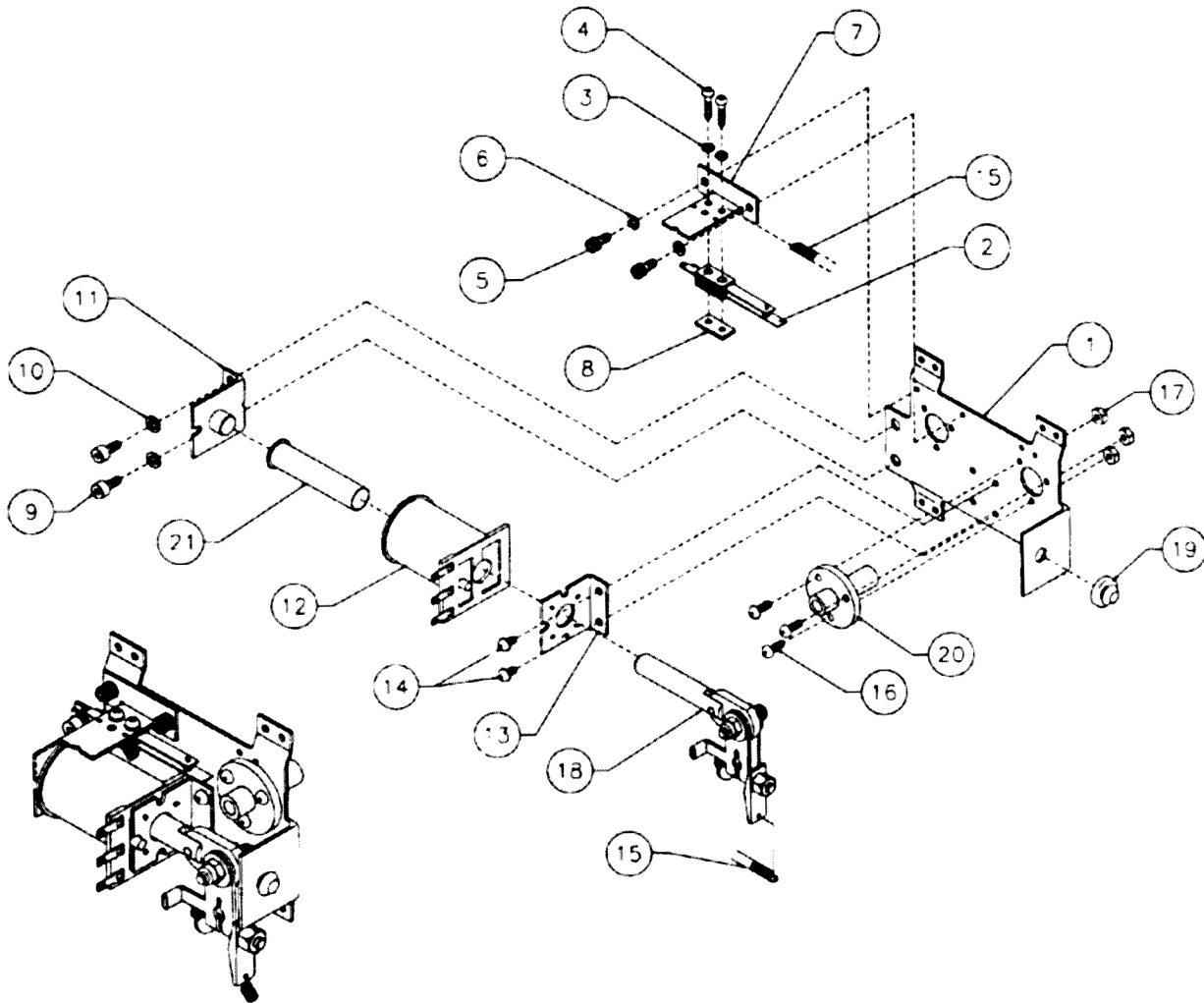

Item	Part Number	Description	Item	Part Number	Description
1	B-13104-L	Flipper Base Assembly, Left	18	A-15848-L	Crank Link Assembly, Left
2	SW-1A-194	Switch Assembly	a)	A-17050-L	Flipper Crank Assembly, Left
3	4701-00002-00	Lock Washer #6 Split	b)	A-15847	Flipper Link Assembly
4	4105-01019-10	Sh. Metal Screw, #5 x 5/8"	c)	02-4676	Link Spacer Bushing
5	4008-01079-05	Mach. Screw, 8-32 x 5/16"	d)	4010-01086-14	Cap Screw, 10-32 x 7/8"
6	4701-00003-00	Lock Washer #8 Split	e)	4700-00023-00	Flat Washer, 5/8 x 13/64 x 16ga.
7	01-9375	Switch Mounting Bracket	f)	4701-00004-00	Lock Washer #10 Split
8	20-6516	Speednut, Tinnerman	g)	4410-01132-00	Nut 10-32 ESN
9	4010-01066-06	Cap Screw, 10-32 x 3/8"	19	23-6577	Bumper Plug, 5/8"
10	4701-00004-00	Lock Washer #10 Split	20	03-7568	Flipper Bushing
11	A-12390	Flipper Stop Assembly	21	03-7066-5	Coil Tubing
12	FL-11629	Flipper Coil, Blue			
13	01-7695-1	Solenoid Bracket			
14	4006-01017-04	Mach. Screw, 6-32 x 1/4"	<b>Associated Parts:</b>		
15	10-364	Spring	(Not Shown)		
16	4006-01005-06	Mach. Screw, 6-32 x 3/8"	21	23-6695	Flipper Ring
17	4406-01117-00	Nut 6-32 Hex.	22	20-10343	Flipper & Shaft

# A-20910 Boogie Man-Kicker Assembly

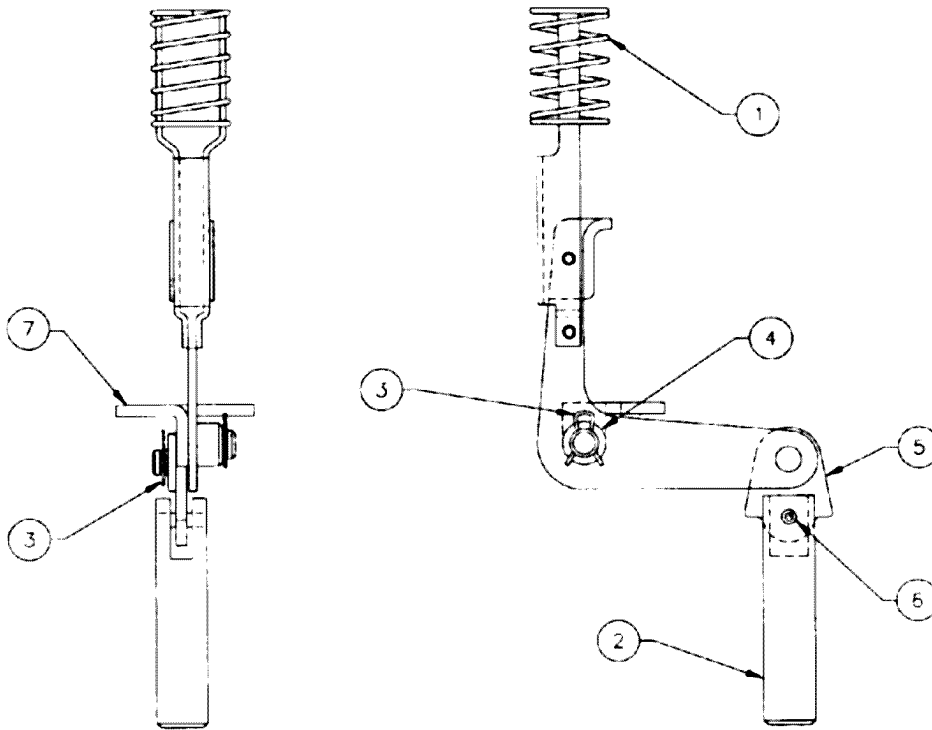

**Associated Assemblies:**  
(Not Shown)

Item	Part Number	Description	Item	Part Number	Description
1	04-10409	Boogie Man Crank Assy.	8	B-9362-L-4	Coil & Bracket Assembly, L.
2	02-2364	Coil Plunger	9	B-9362-R-5	Coil & Bracket Assembly, R.
3	12-6227	Hair Pin Clip	a)	AE-25-1000	Coil Assembly
4	4700-00030-00	Washer, 17/64 x 1/2 x 15ga.	b)	A-17808	Bracket & Stop Assembly
5	03-8085	Armature Link	c)	01-8-508-S	Coil Retainer Bracket
6	20-8716-5	Roll Pin, 1/8 x 7/16"	d)	03-7066	Coil Tubing
7	A-17810	Kicker Mounting Bracket Assy.	e)	4006-01017-06	Mach. Screw, 6-32 x 3/8"
			f)	4406-01119-00	Nut 6-32 ESN
			g)	H-19523	Mini Solenoid Cable
			10	23-6639	Boogie Man
			11	10-128	Spring

# A-17811 Kicker Arm (Slingshot) Assembly

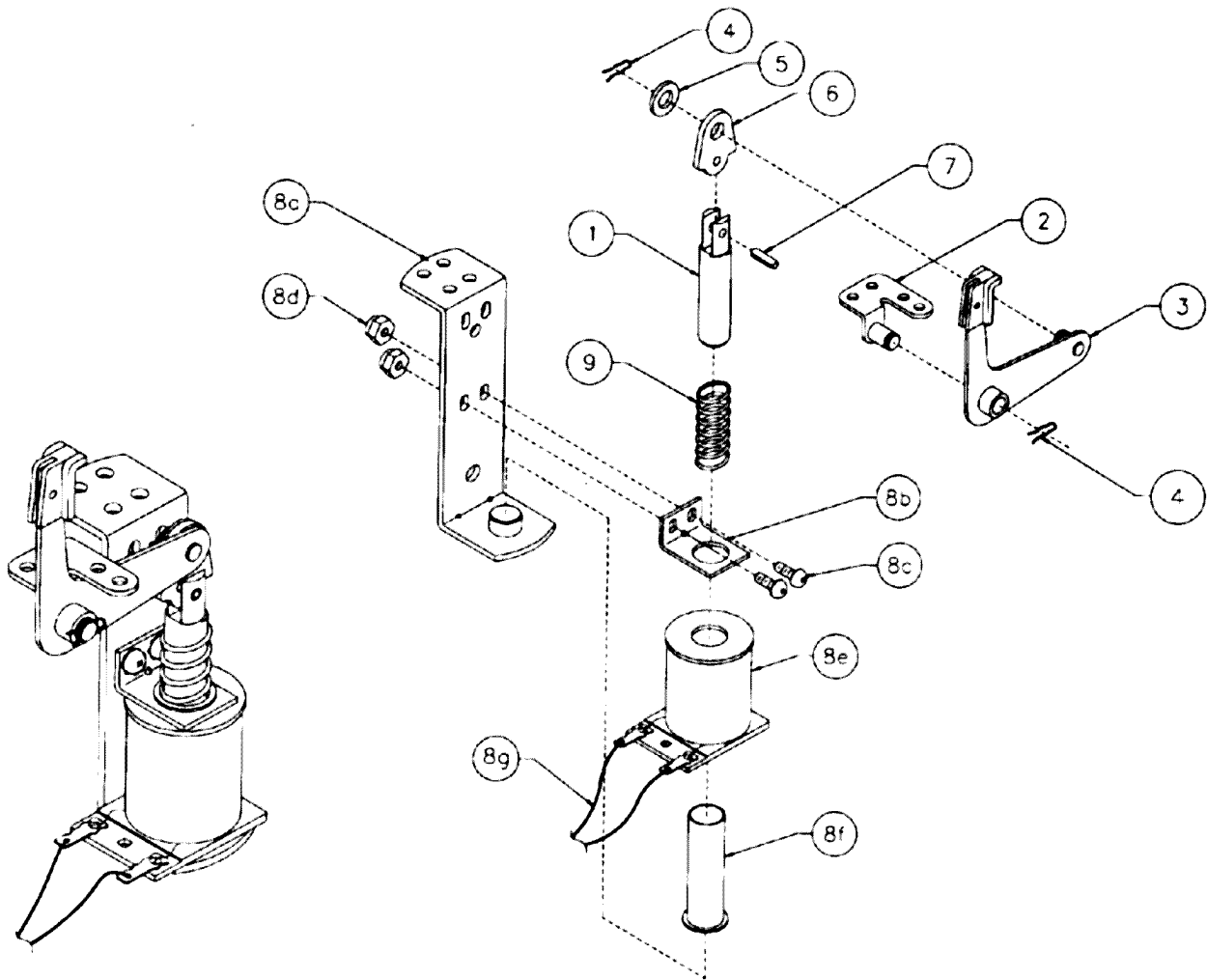

### Associated Parts for Right & Left Kickers:

Item	Part Number	Description	Item	Part Number	Description
1	02-2364	Coil Plunger	8	A-21333-2	Coil & Bracket Assembly, L.
2	A-17810	Mounting Bracket Assembly	a)	A-17808	Bracket & Stop Assembly
3	A-12664	Kicker Crank Assembly	b)	01-8-508-S	Coil Retaining Bracket
4	12-6227	Hairpin Clip	c)	4006-01017-06	Mach. Screw, 6-32 x 3/8"
5	4700-00030-00	FW, 17/64 x 1/2 x 15ga.	d)	4406-01119-00	Nut, 6-32 ESN
6	03-8085	Armature Link	e)	AE-26-1200	Coil Assembly
7	20-8716-5	Roll Pin, 1/8 x 7/16"	f)	03-7066	Coil Tubing
			g)	H-19523	Mini Solenoid Cable
			9	10-128	Spring

# A-19963-1 Ball Trough Assembly Complete

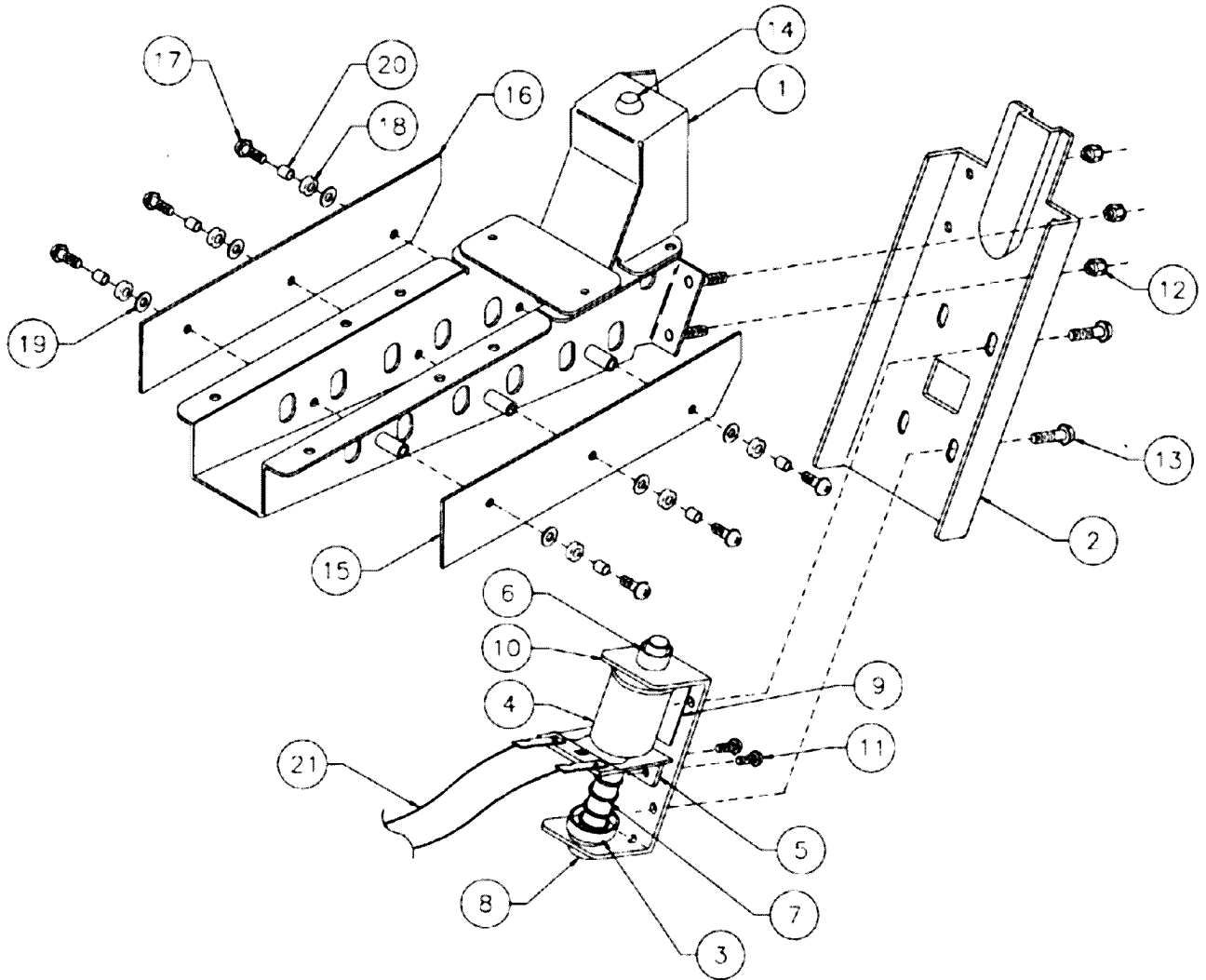

Item	Part Number	Description	Item	Part Number	Description
1	A-16809-2	Ball Trough Welded Assy.	12	4408-01119-00	Nut 8-32 ESN
2	01-11587	Ball Trough Front	13	4008-01017-06	Mach. Screw, 8-32 x 3/8"
3	A-6306-2	Bell Armature Assembly	14	23-6702	Bumper Plug
4	AE-26-1500	Coil Assembly	15	A-18617-1	Trough IRED LED PCB Assembly
5	01-8-508-T	Solenoid Assembly	16	A-18618-1	Trough IRED Transistor PCB Assy.
6	03-7067-5	Coil Tubing	17	4006-01003-10	Mach. Screw, 6-32 x 5/8" SEMS
7	10-135	Spring	18	23-6626	Rubber Grommet
8	23-6420	Rubber Grommet	19	4700-00004-00	Flat Washer, 9/64 x 7/16 x 21ga.
9	03-8523	Insulator	20	02-4975	Bushing
10	01-11586	Coil Mounting Bracket	21	H-19523	Mini Solenoid Cable
11	4008-01017-05	Mach. Screw, 8-32 x 5/16"			

# A-21022 Shooter Lane Kicker Assembly

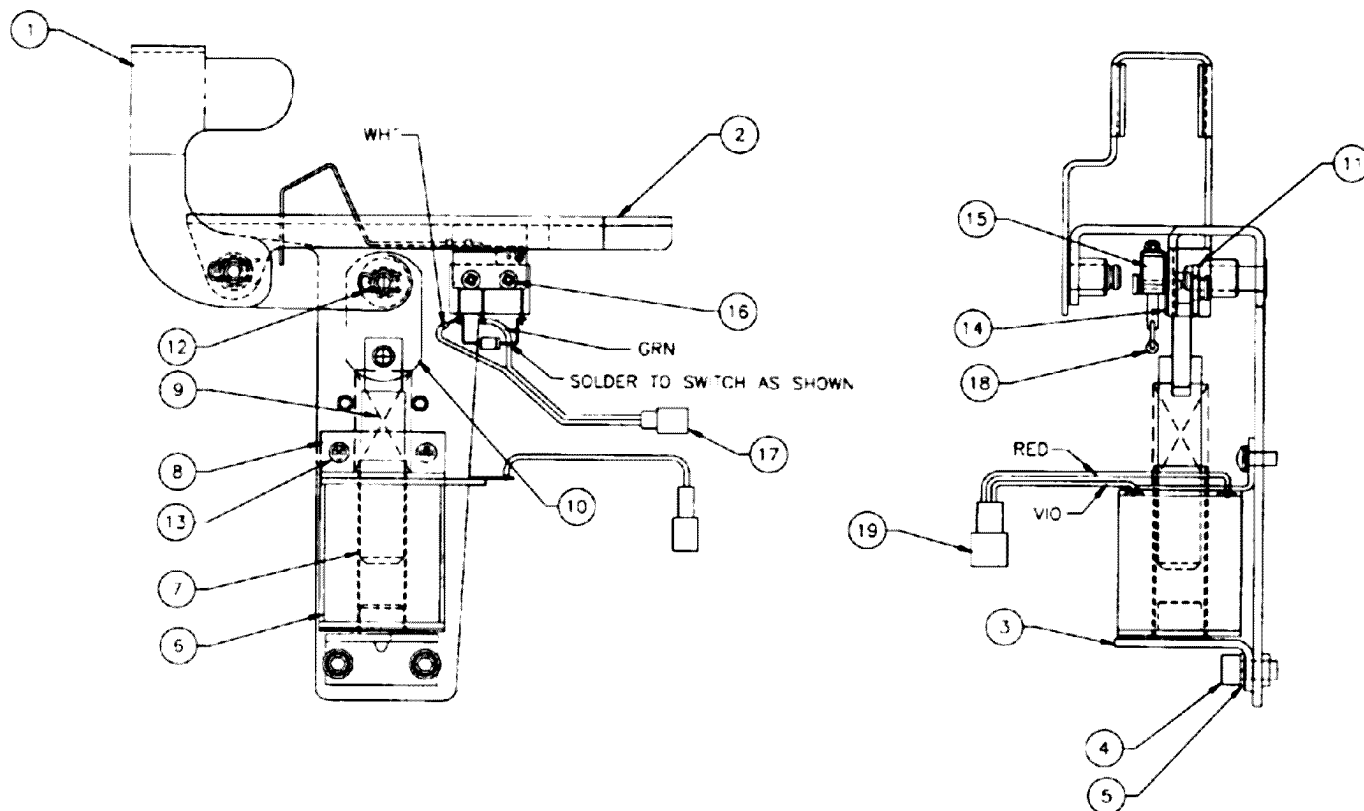

Item	Part Number	Description
1	04-10210.4	Kicker Crank
2	04-10211.5	Coil Mounting Bracket
3	04-10461	Flipper Stop Bracket Assembly
4	4010-01066-06	Cap Screw, #10 x 3/8"
5	4701-00004-00	Lock Washer #10 Split
6	AE-23-800	Coil Assembly
7	03-7066	Coil Tubing
8	01-8413	Coil Mounting Bracket
9	10-128	Spring
10	A-15847	Flipper Link Assembly
11	4700-00104-00	Flat Washer, 23/64 x 1/2 x 16ga.
12	12-6227	Hair Pin Clip
13	4006-01003-05	Mach. Screw, 6-32 x 5/16"
14	01-8600	Insulator
15	5647-12693-65	Mini-Micro Switch
16	4002-01105-08	Mach. Screw, 2-56 x 1/2"
17	H-16437	Cable
18	5070-09054-00	Diode
19	H-19523	Cable



# A-20432-6 Jet Bumper Assembly

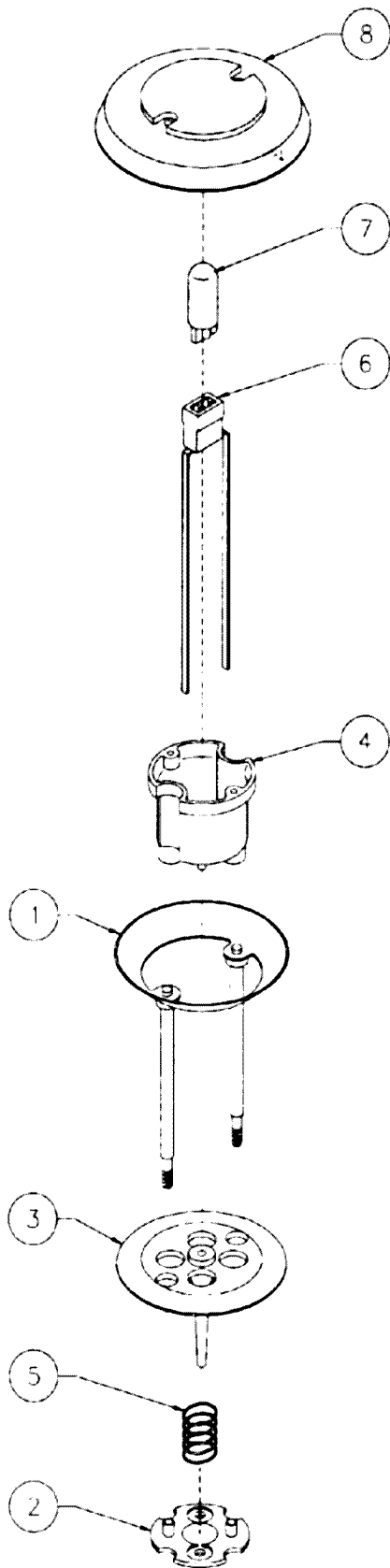

Item	Part Number	Description
1	A-4754	Bumper Ring Assembly
2	03-6009-A5	Bumper Base, White
3	03-6035-7	Bumper Wafer, Black
4	03-7443-5	Bumper Body, White
5	10-7	Spring
6	24-8776	Socket-Wedge Base
7	24-8802	Bulb #906(13v., 0.69A.)

**Associated Parts:**

8	03-9266-10	Jet Bumper Cap, Blue (3)
*9	03-9267-10	Jet Bumper Dome, Blue (3)

\* Not Shown.

# A-9415-2 Jet Bumper Coil Assembly

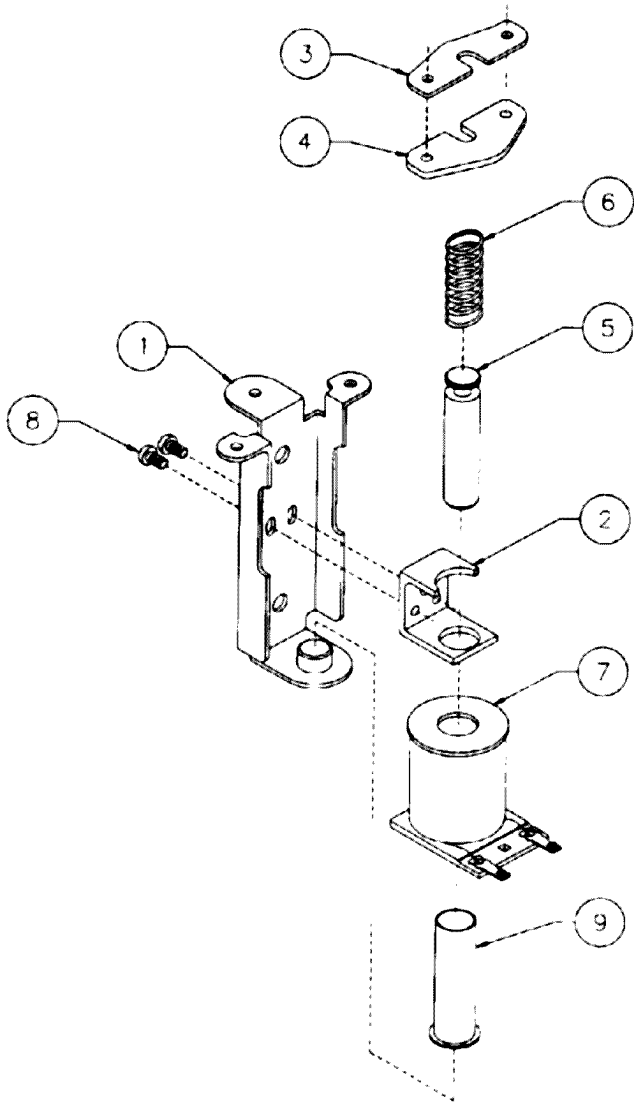

Item	Part Number	Description
1	B-7417	Bracket & Stop Assembly
2	01-1747	Coil Retaining Bracket
3	01-5492	Armature Link, Steel
4	01-5493	Armature Link, Bakelite
5	02-3406-1	Coil Plunger
6	10-326	Armature Spring
7	AE-26-1200	Coil Assembly
8	4006-01017-04	Mach. Screw, 6-32 x 1/4"
9	03-7066	Coil Tubing

**\*Associated Parts:  
(Not Shown)**

10	B-12030-2	Leaf Switch Assembly
a)	A-16443	Switch & Diode Assembly
b)	01-1168	Switch Mounting Bracket
c)	01-3670	Switch Plate
d)	03-7395	Switch Actuator
e)	4005-01003-12	Mach. Screw, 5-40 x 3/4"
f)	4405-01117-00	Nut 5-40 Hex.

## A-20717

### Popper Assembly - Coffin Feed

Item	Part Number	Description
1	04-10349	Popper Assembly
2	4008-01017-03	Mach. Screw, 8-32 x 3/16"
3	A-16908	LED Assembly, RTV
4	A-16909	Photo Trans. Assembly, RTV
5	23-6420	Rubber Grommet
6	01-9794	Mounting Bracket
7	04-10322-2	Coil Retainer Bracket
8	10-135	Spring
9	03-7067-5	Coil Tubing
10	A-17767	Bell Armature Assembly
11	4106-01013-06	Sh. Metal Screw, #6 x 3/8"
12	AE-23-800	Coil Assembly
13	03-7066	Coil Tubing
14	4408-01119-00	Nut 8-32 ESN
15	04-10419	Shaft Assembly
16	H-21283	Coffin Cable
17	AE-26-1500	Coil Assembly
18	12-7342.1	Hinge Pin - Coffin Cover
19	10-513	Spring - Coffin Cover
20	04-10420	Body Plate Assembly
21	12-7343	Hinge Pin - Body Plate
22	A-21308	Coffin Cover Assembly
23	4004-01003-03	Mach. Screw, 4-40 x 3/16"
* 24	31-2589-1	Decal - Coffin
* 25	31-2589-2	Decal - Coffin

---

\* Not available for individual sale. Order Decal Set 31-2589.

# A-20717 Popper Assembly - Coffin Feed

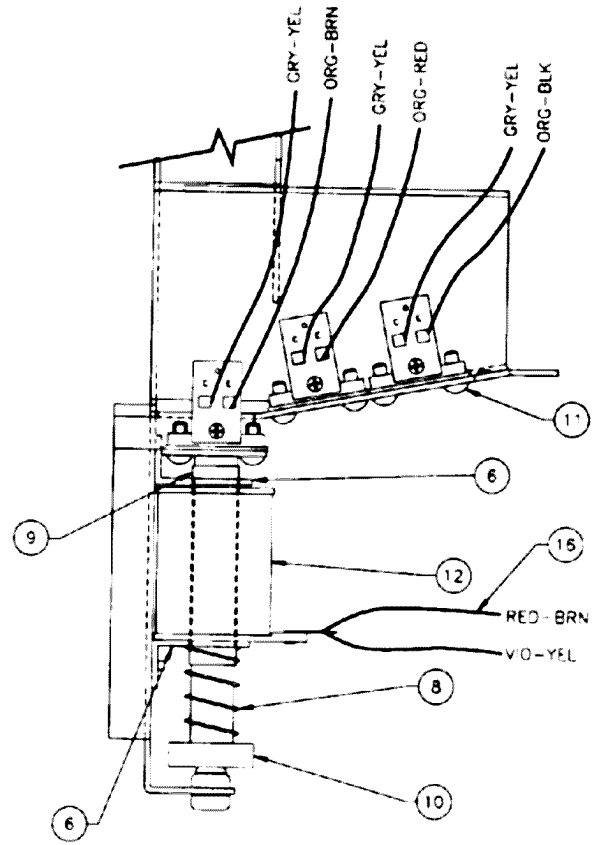
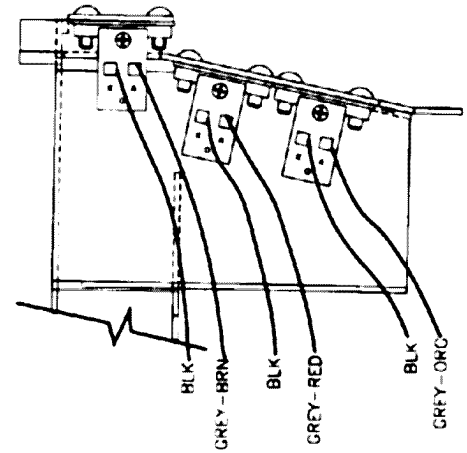
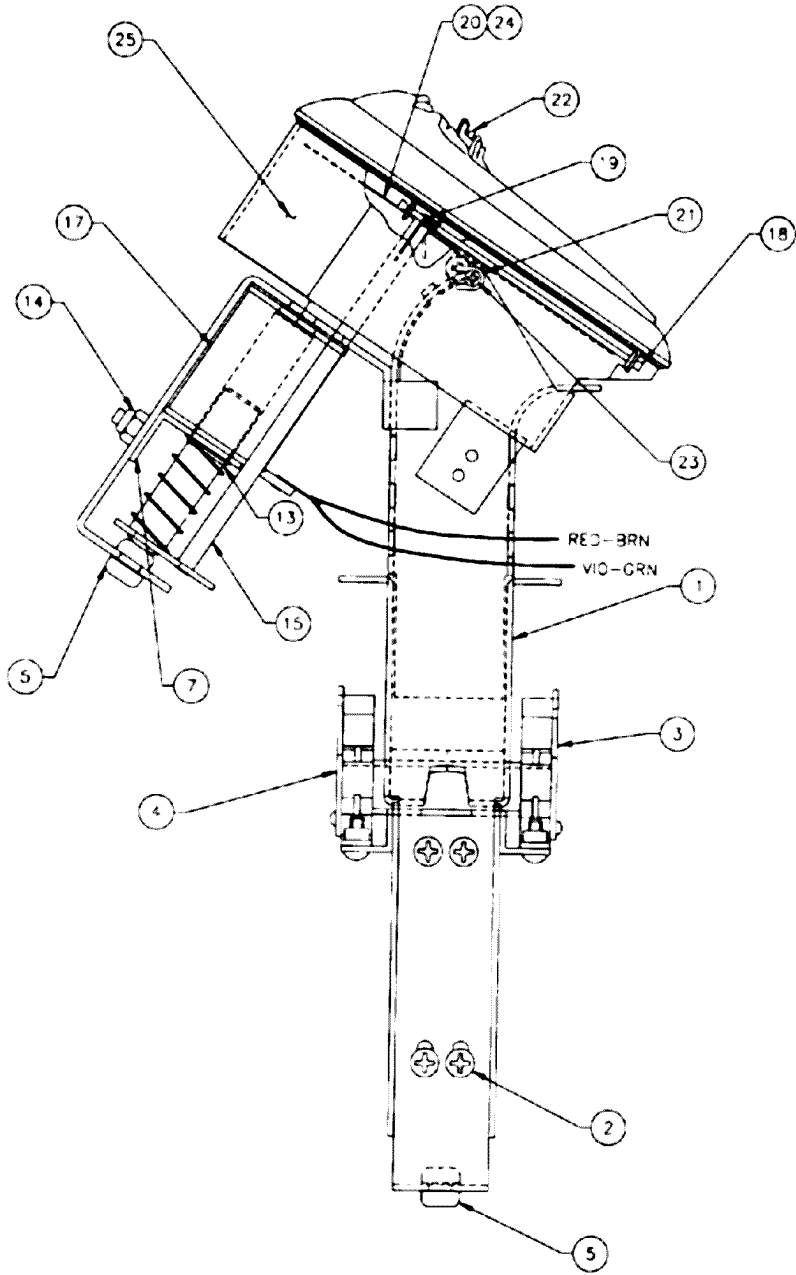

# A-20788 Popper Assembly (Left)

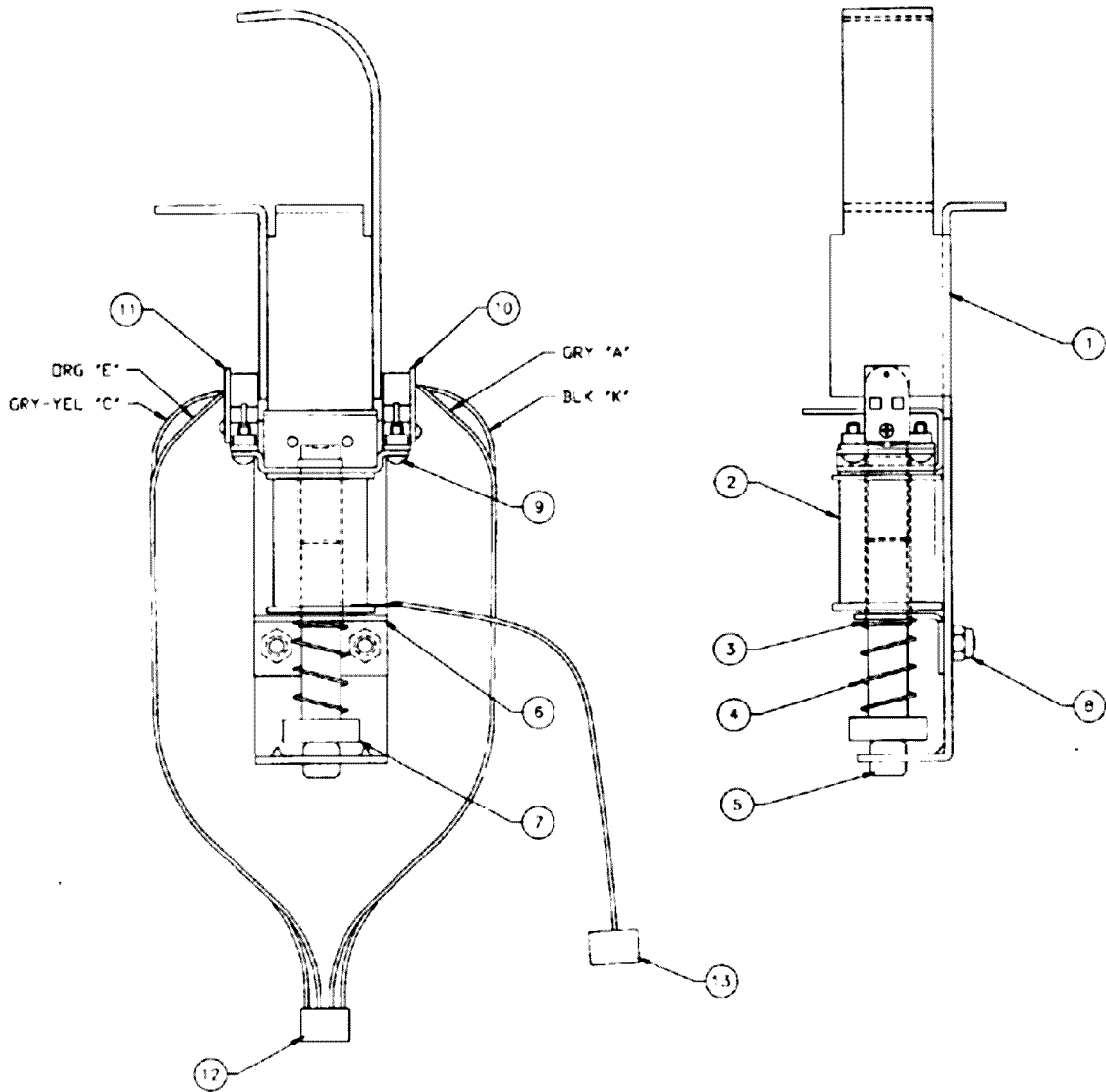

Item	Part Number	Description
1	04-10369	Popper Bracket
2	AE-24-900	Coil Assembly
3	03-7067	Coil Tubing
4	10-135	Solenoid Spring
5	23-6420	Rubber Grommet
6	A-16858	Coil Bracket
7	A-17767	Bell Armature Assembly
8	4408-01119-00	Nut, 8-32 ESN
9	4106-01013-06	Sh. Metal Screw, 6-32 x 3/8"
10	A-16908	LED Assembly, RTV
11	A-16909	Photo Transistor Assy., RTV
12	H-17609-5	Opto Cable, Square
13	H-19523	Mini Coil Cable

# A-20716 Popper Assembly - Jet Exit

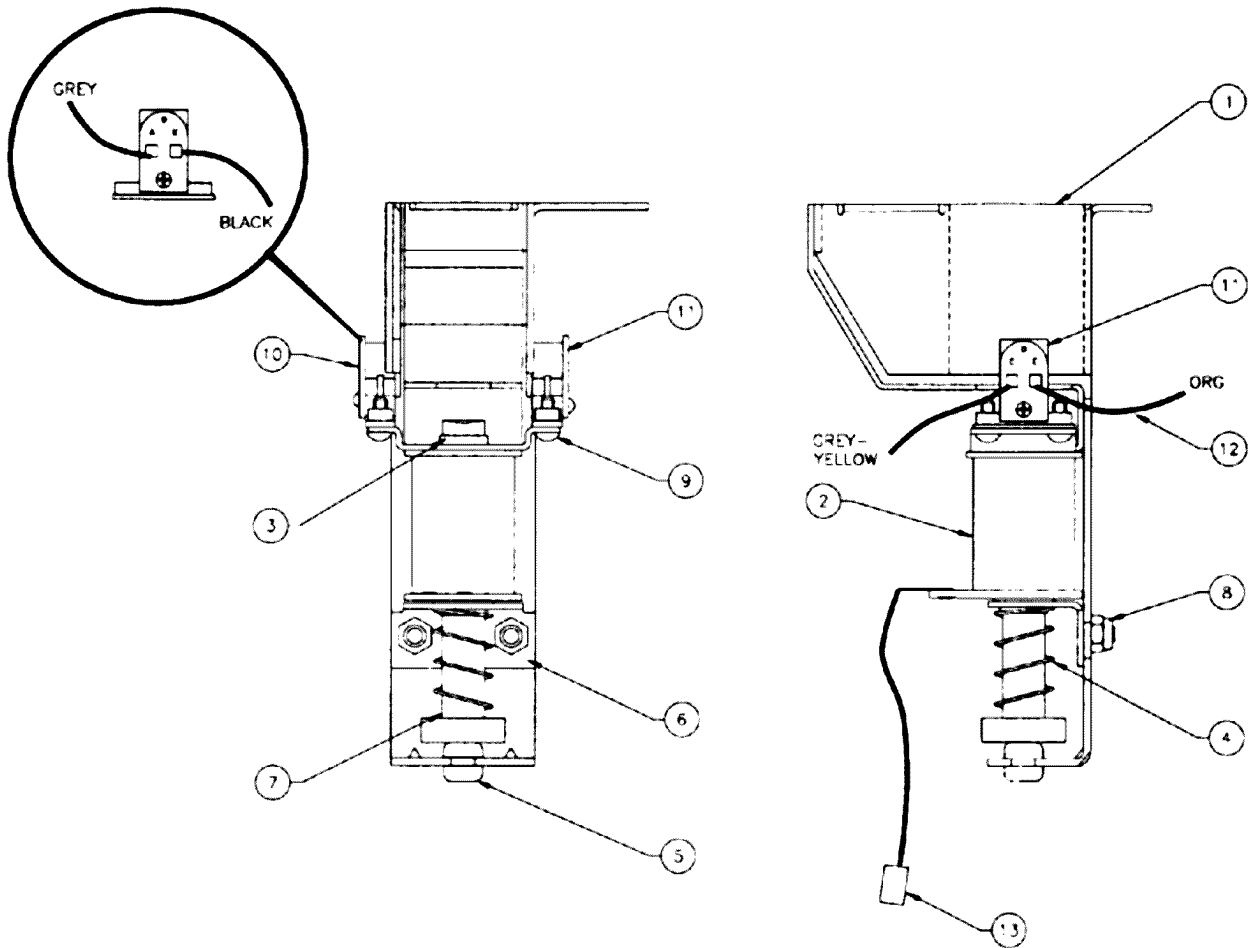

Item	Part Number	Description
1	04-10348	Right Popper
2	AE-24-900	Coil Assembly
3	03-7067	Coil Tubing
4	10-135	Solenoid Spring
5	23-6420	Rubber Grommet
6	04-10086.1	Mounting Bracket
7	A-17767	Bell Armature Assembly
8	4408-01119-00	Nut, 8-32 ESN
9	4106-01013-06	Sh. Metal Screw, #6 x 3/8"
10	A-16908	LED Assembly, RTV
11	A-16909	Photo Trans. Assembly, RTV
12	H-17609-5	Opto Cable, Square
13	H-19523-1	Mini Solenoid Cable

## A-20769 Diverter Drive Assembly (Left)

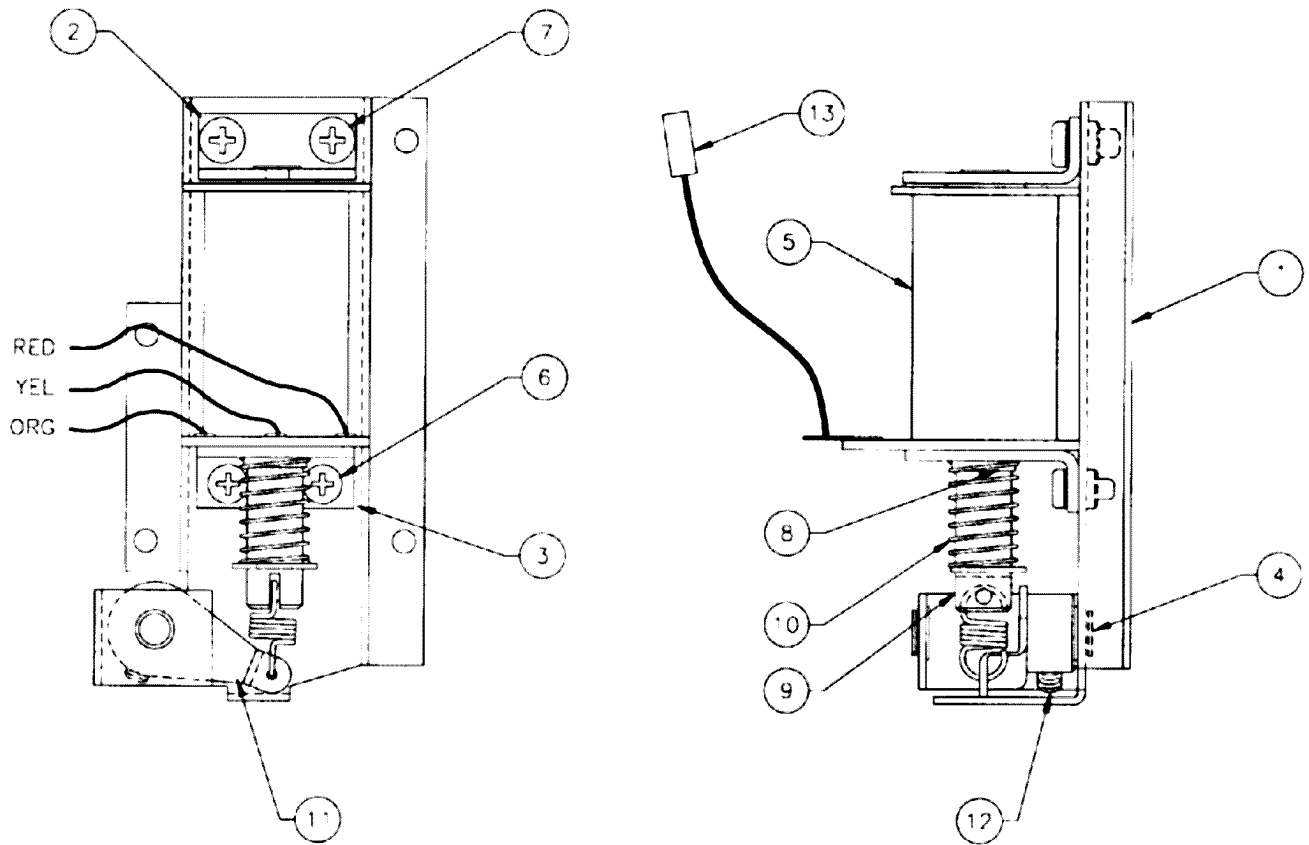

Item	Part Number	Description
1	04-10364.1	Diverter Bracket Assy. (Left)
2	A-12390	Flipper Stop Bracket Assy.
3	01-7695-1	Solenoid Bracket
4	20-8790	Nyliner Bearing
5	A-20099	Coil Assembly
6	4008-01003-06	Mach. Screw, 8-32 x 3/8"
7	4010-01006-05	Mach. Screw, 10-32 x 5/16"
8	03-7066-5	Coil Tubing
9	A-16636	Diverter Plunger Assembly
10	10-303	Spring, Master
11	04-10459	Drive Arm Assembly
12	4010-01169-04	Set Screw, 10-32 x 1/4"
13	H-21008-1	Mini Diverter Cable

# A-20850 Crate Assembly

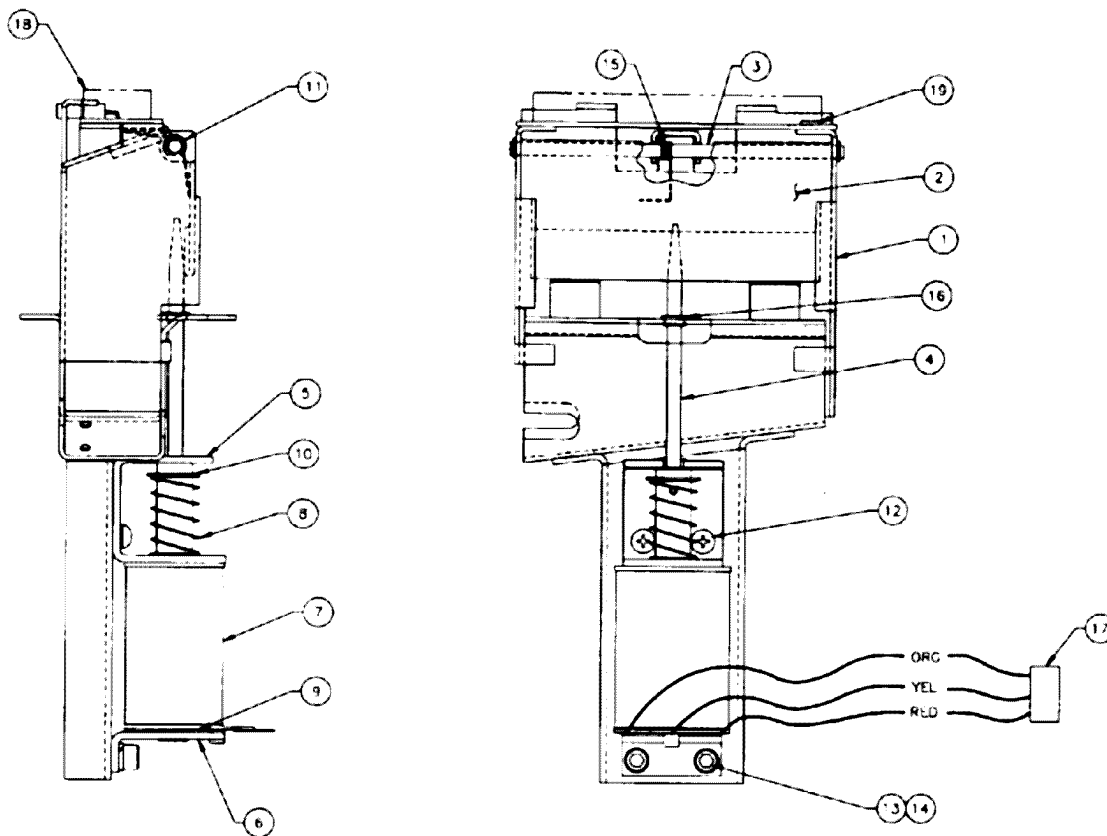

Item	Part Number	Description
1	04-10413.2	Crate Housing Bracket
2	A-21336	Door & Decal Assembly
3	02-5259	Shaft
4	04-10493	Plunger, Door Top
5	01-14277	Coil Mounting Bracket
6	A-12390	Flipper Stop Bracket
7	FL-11629	Flipper Coil Assembly
8	10-395	Plunger Spring
9	03-7066-5	Coil Tubing
10	20-8712-43	Truarc "E" Retaining Ring
11	20-8712-15	Truarc "E" Retaining Ring
12	4008-01017-04	Mach. Screw, 8-32 x 1/4"
13	4010-01066-06	Cap Screw, 10-32 x 3/8"
14	4701-00004-00	Lock Washer #10 Split
15	10-511	Torsion Spring
16	20-8790-1	Nyliner Bearing .188"
17	H-21008-1	Mini Diverter Cable
18	A-21379.1	Crate LED PCB Assembly
19	4006-01003-03	Mach. Screw, 6-32 x 3/16"



# A-20871 Power Interface Assembly

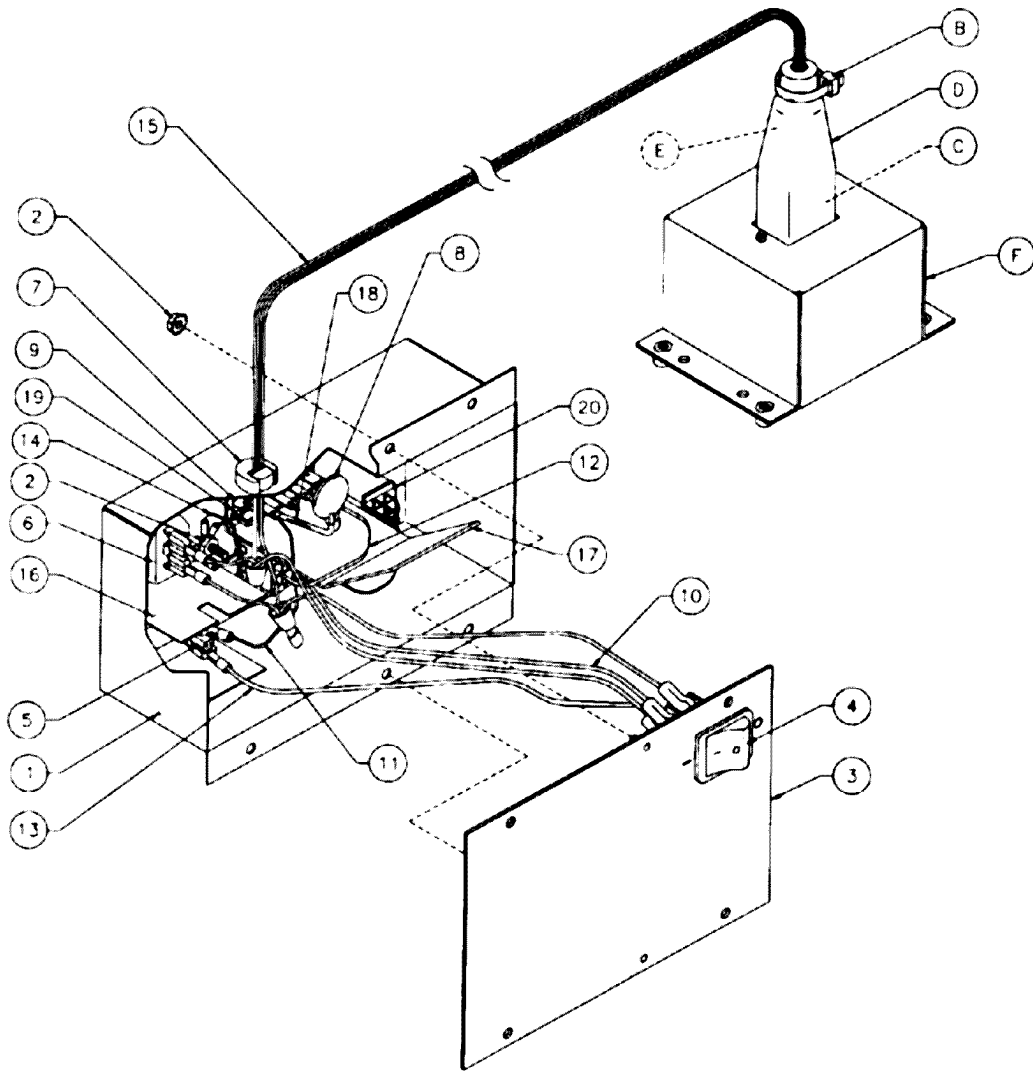

Item	Part Number	Description	Item	Part Number	Description
A	A-20872	Power Control Chassis Assembly	14)	H-17542	Ground Jumper Grn/Yel Cable
1)	04-10292	Power Control Chassis Box	15)	5797-13940-01	Jumper Cable
2)	4406-01128-00	Nut #6-32 KEPS (3)	16)	01-10623	Insulator, Thermistor
3)	01-12294	Switch Mounting Plate Assembly	17)	01-12299	Insulator, Terminal Strip
4)	5642-13935-00	Power Switch	18)	RM-21-06	#18 Vinyl Fgls
5)	5733-14734-00	Fuse Holder Panel (5x20mm)	19)	5822-13865-00	Terminal Strip 3-CKT 2-Mtg.
6)	5851-13867-00	Outlet-IEC Conn. 237 Socket	20)	H-18050	Jumper Cable, Transformer Prog.
7)	03-8712	Strain Relief Bushing	B	03-7933	Ty-Wrap Nylon
8)	5016-12978-00	Thermistor 8A., 2.5R25	C	5045-14007-00	Capacitor, 1µF 275v
9)	4006-01003-10	Mach. Screw, #6-32 x 5/8"	D	23-6776-4	Heat Shrink
10)	H-17992	Jumper Cable Neutral Sw/1FC	E	RM-21-06	#18 Vinyl Sleeving
11)	H-17543	Hot Jumper Black Cable	F	A-20873	Line Filter Entry Chassis
12)	H-17546	Jumper Interface Hot Black Cable			
13)	H-17545	Jumper Switch/Fuse Black Cable			

## Power Interface/Cordset Application

COUNTRY	UNIVERSAL PWR INTERFACE ASSEMBLY	VOLTAGE PROGRAMMING JUMP CABLE				5AMP FUSE/ LABEL	8AMP FUSE/ LABEL	LABEL HIGH VOLTAGE CAUTION	POWER ADAPTER CORD	CORDSET										
		H-17837-1	H-17837-2	H-17837-3	H-17837-4					5731-09651-00 FUSE 16-9668 LABEL	5730-09252-00 FUSE 16-9670 LABEL	15-9669	5850-14052-00	5850-13271-00	5850-13272-00	5850-13273-00	5850-13274-00	5850-13275-00	5850-13276-00	5850-13277-00
UNITED STATES	X		X				X X		X	X										
CANADA	X	X					X X			X										
TAIWAN	X		X				X X			X										
MEXICO	X		X				X X			X										
CENTRAL AMERICA	X		X				X X			X										
SOUTH KOREA	X		X				X X			X										
PUERTO RICO	X		X				X X			X										
AUSTRIA	X			X	X X			X			X									
BELGIUM	X			X	X X			X			X									
FINLAND	X			X	X X			X			X									
FRANCE	X			X	X X			X			X									
GREECE	X			X	X X			X			X									
HOLLAND	X			X	X X			X			X									
HUNGARY	X			X	X X			X			X									
NETHERLANDS	X			X	X X			X			X									
NETH ANTILLES	X			X	X X			X			X									
NORWAY	X			X	X X			X			X									
POLAND	X			X	X X			X			X									
PORTUGAL	X			X	X X			X			X									
SPAIN	X			X	X X			X			X									
SWEDEN	X			X	X X			X			X									
TURKEY	X			X	X X			X			X									
WEST GERMANY	X			X	X X			X			X									
UNITED KINGDOM	X			X	X X			X				X								
IRELAND	X			X	X X			X				X								
HONG KONG	X			X	X X			X				X								
DENMARK	X			X	X X			X					X							
ITALY	X			X	X X			X						X						
CHILE	X			X	X X			X							X					
PEOPLE'S REP. OF CHINA	X			X	X X			X							X					
SWITZERLAND	X			X	X X			X								X				
AUSTRALIA	X			X	X X			X											X	
NEW ZEALAND	X			X	X X			X											X	
ARGENTINA	X			X	X X			X											X	
JAPAN	X				X		X X												X	X

# A-20835 Back Panel Assembly

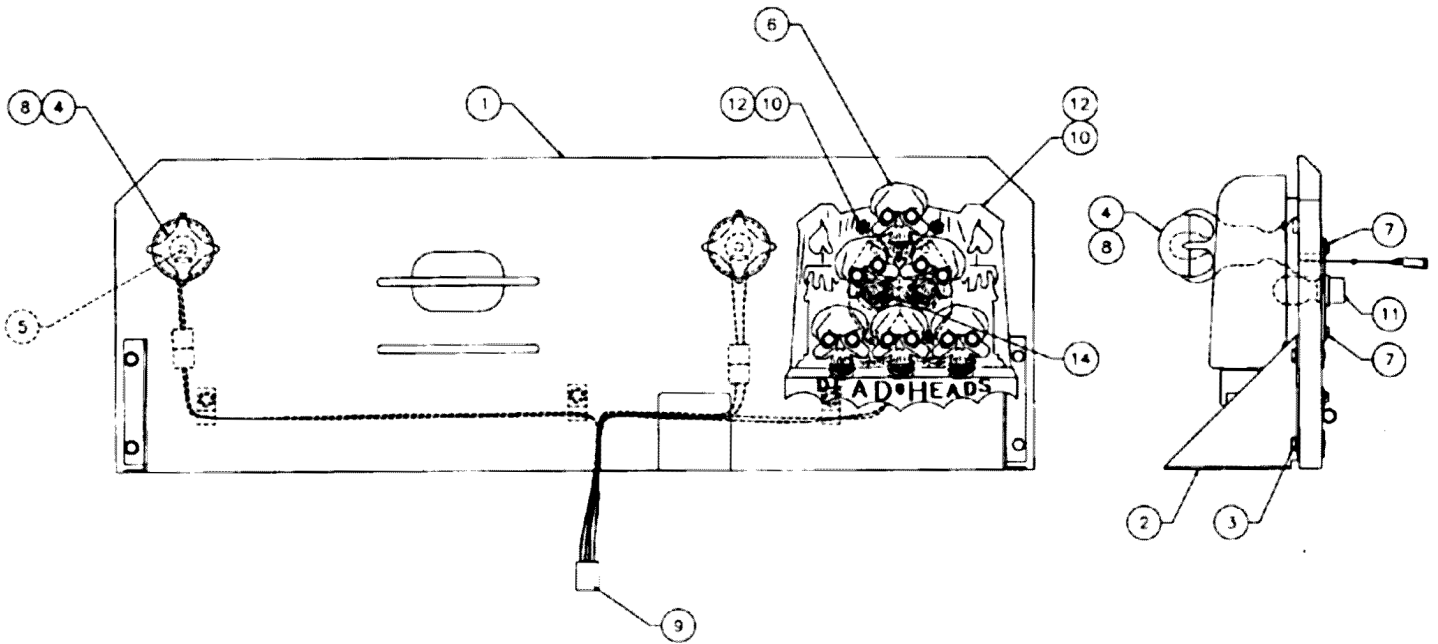

Item	Part Number	Description
1	04-10384.2	Back Panel
2	01-12569	Gusset - Back Panel
3	4008-01168-10	Mach. Screw, 8-32 x 5/8"
4	A-20844	Claw Flasher Assembly
5	4008-01113-12	Mach. Screw, 8-32 x 3/4"
6	31-2572.1	Skull Pile
7	4808-01175-07Y	E-P #8 x 7/16"
8	03-9441-9	Globe Light - Trans. Red
9	H-21276.1	Back Panel Cable
10	03-6047-7	Spacer 1/8" Long
11	A-20158	Single Flasher Lamp Assy.
12	4105-01019-10	Sh. Metal Screw, #5 x 5/8"
13	03-7655-4	Wire Harness Clip, .25"
14	03-9575-1	Lite Sleeve, Large

# A-17796 Ball Gate Actuator Assembly

Item	Part Number	Description
1	01-12348	Ball Gate Coil Assembly
2	A-14406	Coil Assembly
3	A-11146	Armature Assembly
4	A-6892	Frame & Eyelet Assembly
5	10-120	Spring
6	4701-00003-00	Lock Washer #8 Split
7	4700-00089-00	FW, 11/64 x 7/16 x 16ga.
8	4008-01021-07	Mach. Screw, 8-32 x 7/16"
9	10-194	Extension Spring

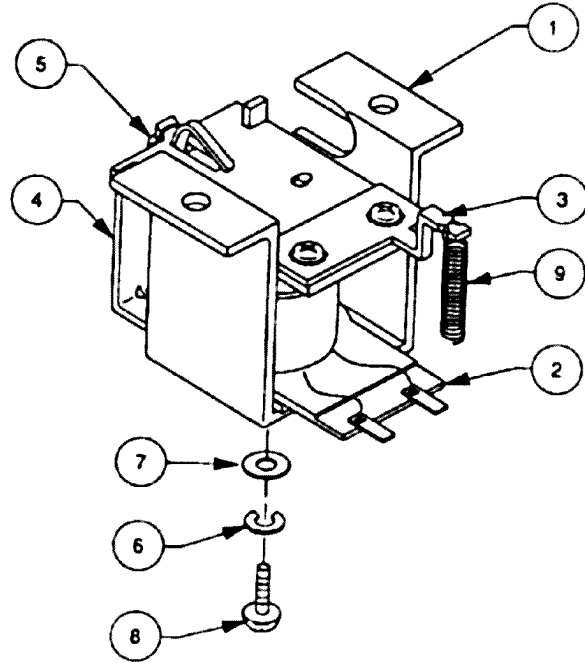

## 04-10346 Tilt Mechanism Assembly

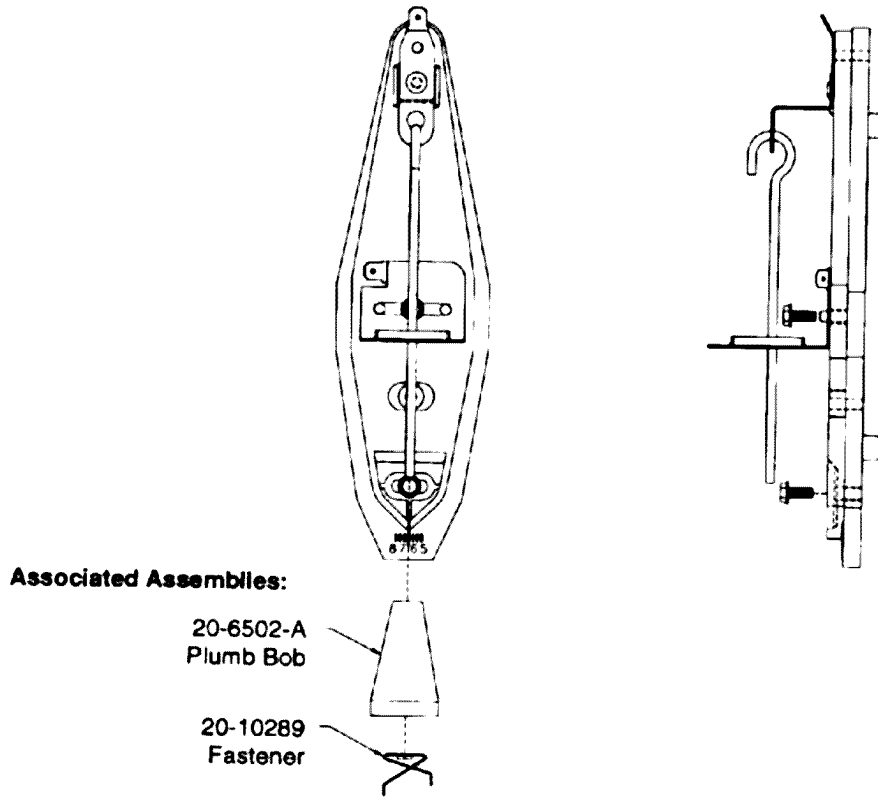

## B-10686-1 Knocker Assembly

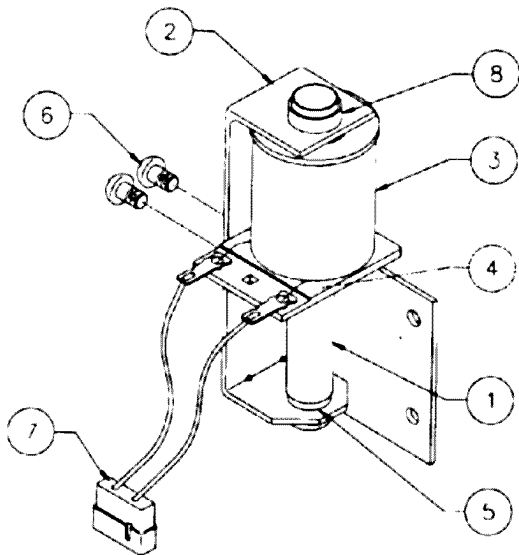

Item	Part Number	Description
1	A-5387	Coil Plunger Assembly
2	01-11273	Mounting Bracket Assembly
3	AE-23-800	Coil Sub-Assembly
4	01-8-508-T	Coil Retaining Bracket
5	23-6420	Rubber Grommet
6	40008-01017-04	Mach. Screw, 8-32 x 1/4"
7	H-11835	Knocker Cable
8	03-7067-5	Coil Tubing

# Ramps

Item	Part Number	Description
1	A-20753	Left Plastic Ramp Assy.
a)	31-2577	Skull
b)	A-20947	Skull Mtg. Bracket Assy.
c)	31-2571	Skeleton Rib
2	A-20754	Right Plastic Ramp Assy.
a)	A-20844	Claw Flasher Assy.
b)	03-9441-9	Globe Light-Transp. Red

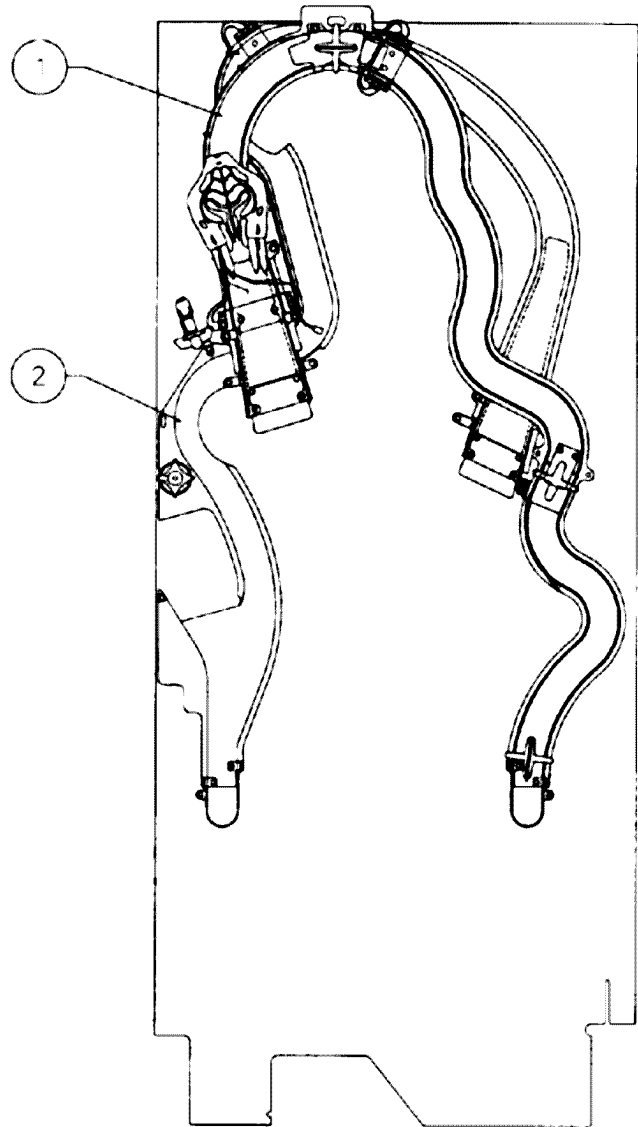

# Upper Playfield Parts

Item No.	Part Number	Description	NOT SHOWN:	
2	20-10343	Flipper & Shaft	36-50048	† Screened Playfield
3	03-9216-13	Flipper Return Guide, Clear	01-12624	Lwr Bottom Arch Mtg. Brkts. (2)
	03-9613-2	Flipper Ball Guide Bone, Left	12-7210	Rebound Wire (2)
4	A-20910	Kicker Assembly	A-21334-1	Playfield Plastic Assembly
	23-6639	Boogie Man	A-21334-2	Playfield Plastic Assembly
	10-128	Spring	A-21334-3	Playfield Plastic Assembly
5	31-2568-2	Slingshot Bone, Left	A-21334-4	Playfield Plastic Assembly
7	A-20717	Coffin Feed Popper Assembly	A-21334-5	Playfield Plastic Assembly
	31-2589-1	Coffin Decal	A-21334-6	Playfield Plastic Assembly
	31-2589-2	Coffin Decal	A-21334-7	Playfield Plastic Assembly
8	A-20783-7	Stationary Pop Target	A-21334-8	Playfield Plastic Assembly
	A-20782	Pop Target Assembly	A-13204-50048	Bottom Arch Assembly
	04-10510	Frog Assembly	20-6500-1	1/16" Steel Ball (4)
9	01-14255	Ball Guide	03-9600-1	Full Playfield Mylar
10	01-14248	Ball Catcher Bracket	03-9600-2	Playfield Mylar
11	A-20769	Diverter Drive Assembly	03-9600-3	Playfield Mylar
	04-10367.1	Diverter Blade Assembly	03-9600-4	Playfield Mylar
12	01-14336	Ball Guide	03-9600-5	Playfield Mylar
13	01-14254	Ball Guide	03-9600-6	Playfield Mylar
14	12-6466-9	Ball Guide Wire 2 ½"		
15	12-7349	Ball Guide Wire	* Not Shown	
16	12-7350	Ball Guide Wire	** Located Under Playfield	
17	01-14253	Ball Guide	† The <b>Scared Stiff</b> hardcoat playfield does not require a full mylar. However, mylars can be purchased through your local Bally Distributor.	
18	03-8318-9	Lite Hood, Red (4)		
19	A-12120	Ball Gate & Bracket Assembly		
20	A-17797-1	Ball Gate Special Assy., Right		
21	A-20835	Back Panel Assembly		
22	01-14249	Ball Guide		
23	12-7351	Ball Guide Wire		
24	A-9465-R	Ball Gate & Wire Assembly		
25	01-14252	Ball Guide		
26	01-14251	Ball Guide		
27	B-9414-6	Jet Bumper Assembly, Black		
	03-9266-10	Jet Bumper Cap, Blue		
	03-9267-13	Jet Bumper Dome, Clear		
28	A-21335	Crate Assembly		
29	01-14256	Ball Guide		
30	A-21263	Switch Gate Assembly		
31	A-21032	Gate & Trap Door Assembly		
32	01-14257	Ball Guide		
33	A-21339	Ball Gate & Wire Assembly		
34	01-14416	Ball Guide		
35	31-2568-1	Slingshot Bone, Right		
36	A-20910	Kicker Assembly		
	10-128	Kicker Spring		
	23-6639	Boogie Man		
37	03-9216-13	Flipper Return Guide, Clear		
	03-9613-1	Flipper Ball Guide Bone, Right		
38	A-15802-P	Level		
39	01-10621	Strike Plate		
40	A-21022	Shooter Lane Auto Kicker Assy.		
41	A-12120-1	Ball Gate & Wire Assembly		

# Upper Playfield Parts

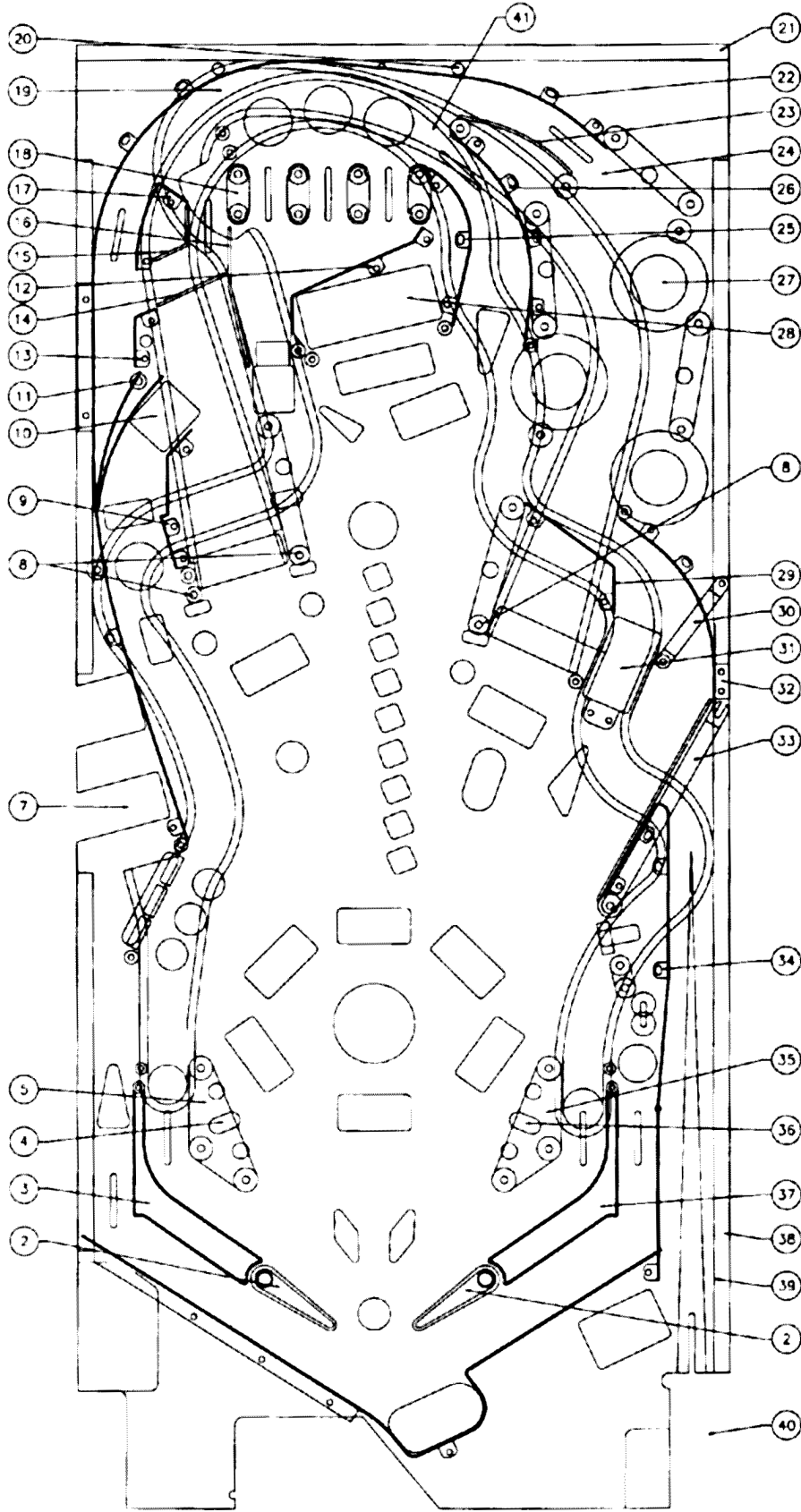



# Lower Playfield Parts

Item	Part Number	Description
1	A-19963-1	Ball Trough Assembly w/Cable
2	01-11781	Support Bracket Assembly (2)
3	A-21022	Shooter Lane Auto Kicker Assy.
4	A-14876-R-3	Flipper Assembly
5	B-9362-R-5	Coil & Bracket Assembly
	* A-20910	Kicker Assembly-Boogie Man
6	A-21287-1	6-Lamp/Flasher Assembly
7	A-20781-1	16-LED Skull Driver PCB Assy.
8	A-17223	16-Opto PCB Assy. w/Bracket
9	A-20716	Jet Exit Popper Assembly
10	A-21277	4-Lamp PCB Assembly
11	A-9415-2	Jet Bumper Coil Assembly (3)
	* A-20432-6	Jet Bumper Assembly (3)
12	A-17749-1-2	Pfkd. Slide Mechanism Assy., R.
13	A-18535-2	Eddy Sensor PCB Assembly
14	A-21289	3-Lamp PCB Assembly
15	A-17796	Ball Gate Actuator
16	A-21305	3-Lamp PCB Assembly
17	A-20850	Crate Assembly
18	A-17749-1-1	Pfkd. Slide Mechanism Assy., L.
19	A-20769	Diverter Assembly, Left
	* 04-10367	Diverter Blade Assembly, Left
20	A-20788	Left Popper Assembly
21	01-14248	Ball Catch Bracket
22	A-21290	3-Lamp PCB Assembly
23	A-21333-2	Coil & Bracket Assembly
	* A-17811	Kicker Arm (Slingshot) Assy.
24	A-21254	Under Playfield Trough
25	A-20717	Coffin Feed Popper Assembly
26	A-21292	11-Lamp PCB Assembly
27	A-21291	3-Lamp PCB Assembly
28	B-9362-L-4	Coil & Bracket Assembly
	* A-20910	Kicker Assembly-Boogie Man
29	A-15849-L-2	Flipper Assembly

**Note:**

\* Denotes item located on top of playfield.

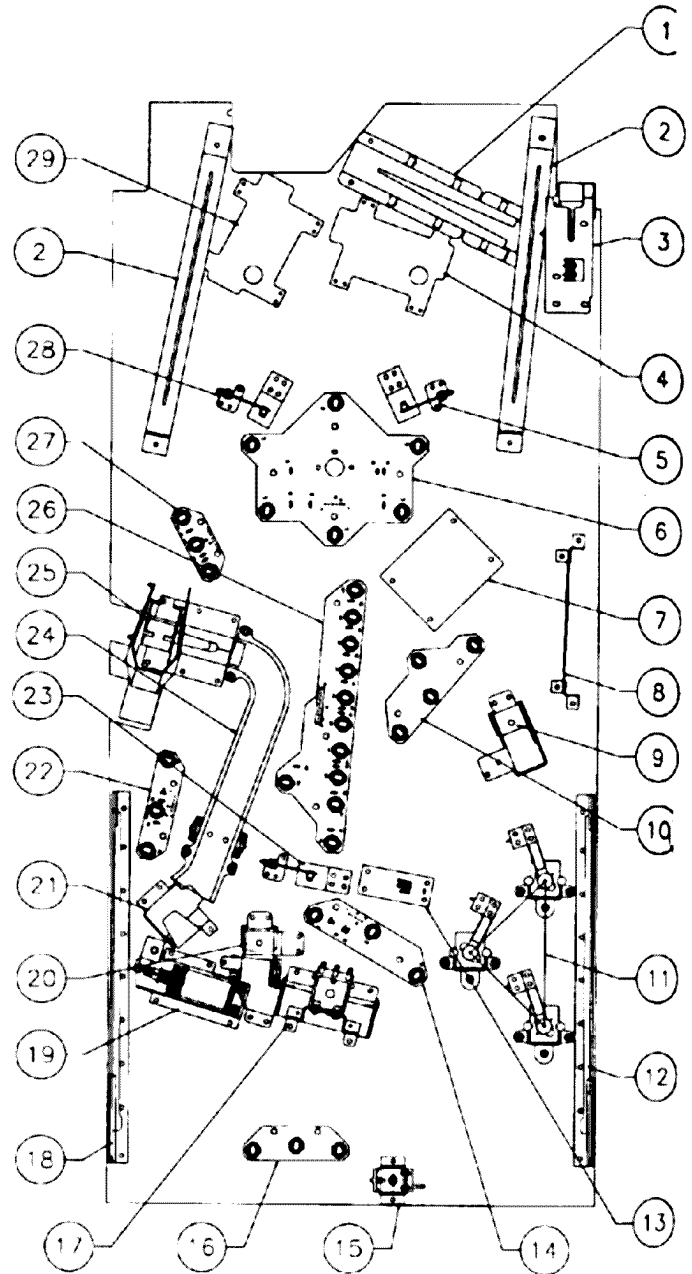

# Rubber Rings

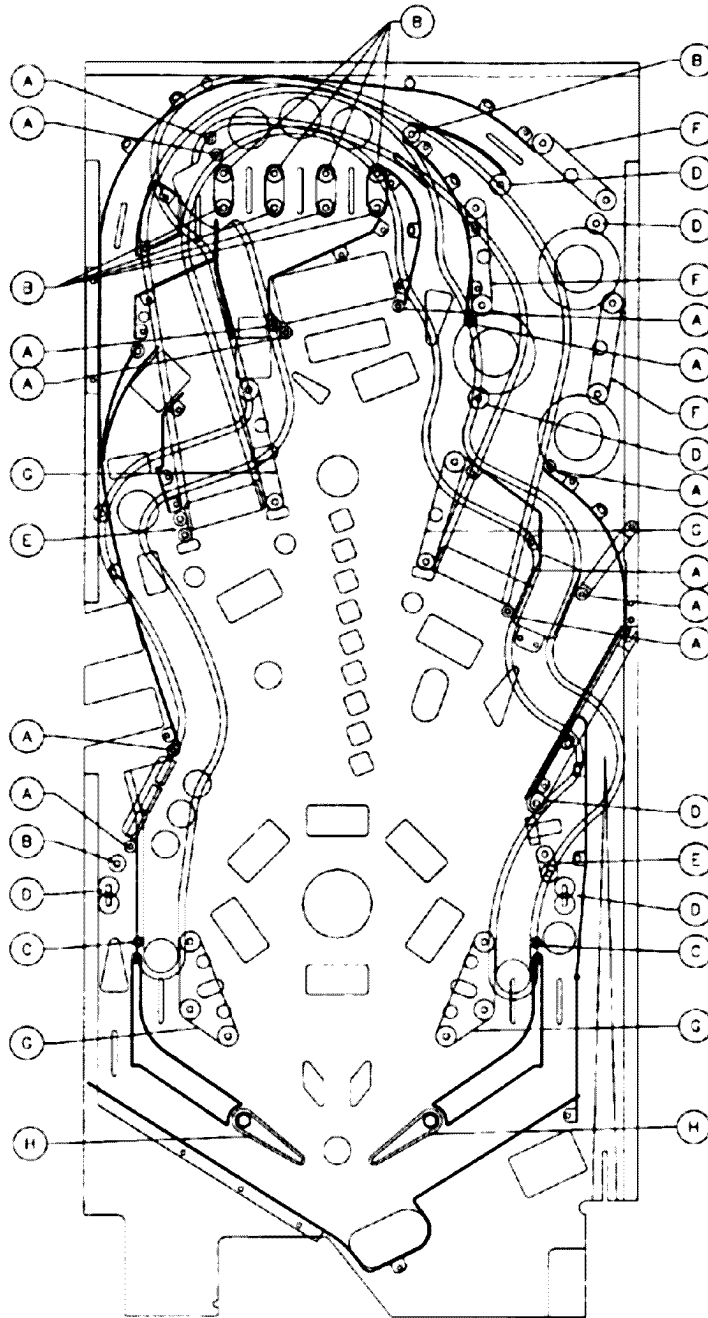

Item No.	Part Number	Description.	Qty	Item No.	Part Number	Description.	Qty
A	23-6556	Rubber Bumper Sleeve	12	E	23-6694-4	Rubber Bumper 7/16"	2
B	23-6641	Rubber Bumper .64 OD	10	F	23-6694-9	Rubber Bumper 2"	6
C	23-6694-1	Grommet	2	G	23-6694-10	Rubber Bumper 2 1/2"	4
D	23-6694-3	Rubber Bumper 5/16"	8	H	23-6695	Flipper Ring	2
				I	23-6327	*Ball Shooter Tip	1

\*Not Shown

# LAMP MATRIX

Yellow (B+) 0 Red

Column \ Row	1 Yellow-Brown J121-1 Q98	2 Yellow-Red J121-2 Q100	3 Yellow-Orange J121-3 Q95	4 Yellow-Black J121-4 Q99	5 Yellow-Green J121-5 Q94	6 Yellow-Blue J121-6 Q98	7 Yellow-Violet J121-7 Q93	8 Yellow-Gray J121-9 Q97
1 Red-Brown J125-1 Q104	STIFF LEVEL 7 <small>11</small>	STIFF LEVEL 8 <small>21</small>	CRATE LEFT EYE <small>31</small>	LEFT LEAPER <small>41</small>	RAMP ITEM <small>51</small>	LABORATORY ITEM <small>61</small>	WEB AWARD 7 <small>71</small>	WEB AWARD 15 <small>81</small>
2 Red-Black J125-2 Q108	STIFF LEVEL 6 <small>12</small>	STIFF LEVEL 9 <small>22</small>	CRATE CENTER LEFT <small>32</small>	LEFT RAMP JACKPOT <small>42</small>	COFFIN MULTIBALL ITEM <small>52</small>	CRATE ITEM <small>62</small>	WEB AWARD 8 <small>72</small>	WEB AWARD 16 <small>82</small>
3 Red-Orange J125-4 Q103	STIFF LEVEL 5 <small>13</small>	SCARED STIFF <small>23</small>	CRATE CENTER RIGHT <small>33</small>	LIGHT LOCK <small>43</small>	LEAPER ITEM <small>53</small>	SKULL ITEM <small>63</small>	WEB AWARD 9 <small>73</small>	WEB AWARD 1 <small>83</small>
4 Red-Yellow J125-5 Q107	STIFF LEVEL 4 <small>14</small>	CENTER LEAPER <small>24</small>	CRATE RIGHT EYE <small>34</small>	RAMP RIGHT EYE <small>44</small>	COFFIN SPOTLIGHT <small>54</small>	WEB AWARD 2 <small>64</small>	WEB AWARD 10 <small>74</small>	LEFT SKULL LANE <small>84</small>
5 Red-Green J125-6 Q102	STIFF LEVEL 3 <small>15</small>	THREE BANK LOWER <small>25</small>	LEFT OUTLANE <small>35</small>	RIGHT OUTLANE <small>45</small>	SHOOT AGAIN <small>55</small>	WEB AWARD 3 <small>65</small>	WEB AWARD 11 <small>75</small>	CENTER SKULL LANE <small>85</small>
6 Red-Blue J125-7 Q106	STIFF LEVEL 2 <small>16</small>	THREE BANK MIDDLE <small>26</small>	RIGHT LEAPER <small>36</small>	SKILL SHOT <small>46</small>	LOCK LAMP <small>56</small>	WEB AWARD 4 <small>66</small>	WEB AWARD 12 <small>76</small>	RIGHT SKULL LANE <small>86</small>
7 Red-Violet J125-8 Q101	STIFF LEVEL 1 <small>17</small>	THREE BANK UPPER <small>27</small>	RIGHT RAMP JACKPOT <small>37</small>	CRATE JACKPOT <small>47</small>	LEFT LOOP CENTER <small>57</small>	WEB AWARD 5 <small>67</small>	WEB AWARD 13 <small>77</small>	BUY IN <small>87</small>
8 Red-Gray J125-9 Q105	RAMP LEFT EYE <small>18</small>	SPIDER POPPER <small>28</small>	LIGHT SPIN SPIDER <small>38</small>	EXTRA BALL <small>48</small>	LEFT LOOP UPPER <small>58</small>	WEB AWARD 6 <small>68</small>	WEB AWARD 14 <small>78</small>	START BUTTON <small>88</small>

J1XX = Power Driver Board

## LAMP LOCATIONS

Item No.	Bulb No.	Lamp Assy. No.	Description	Item No.	Bulb No.	Lamp Assy. No.	Description
11	24-8768	A-21292	Stiff Level 7	41	24-6549	A-17835	Left Leaper
12	24-8768	A-21292	Stiff Level 6	42	24-6549	A-20507	Left Ramp Jackpot
13	24-8768	A-21292	Stiff Level 5	43	24-6549	A-20507	Light Lock
14	24-8768	A-21292	Stiff Level 4	44	24-6549	04-10514	Ramp Right Eye
15	24-8768	A-21292	Stiff Level 3	45	24-6549	A-17807	Right Outlane
16	24-8768	A-21292	Stiff Level 2	46	24-8768	A-21289	Skill Shot
17	24-8768	A-21292	Stiff Level 1	47	24-8768	A-21289	Crate Jackpot
18	24-6549	04-10514	Ramp Left Eye	48	24-6549	A-17808	Extra Ball
21	24-8768	A-21292	Stiff Level 8	51	24-6549	A-17835	Ramp Item
22	24-8768	A-21292	Stiff Level 9	52	24-6549	A-17835	Coffin Multiball Item
23	24-8768	A-21292	Scared Stiff	53	24-6549	A-17835	Leaper Item
24	24-8768	A-21292	Center Leaper	54	24-8768	04-10094	Coffin Spotlight
25	24-8768	A-21291	Three Bank Lower	55	24-6549	A-17808	Shoot Again
26	24-8768	A-21291	Three Bank Middle	56	24-8768	A-21290	Lock Lamp
27	24-8768	A-21291	Three Bank Upper	57	24-8768	A-21290	Left Loop Center
28	24-8768	A-21288	Spider Popper	58	24-8768	A-21290	Left Loop Upper
31	---	A-21379	Crate Left Eye	61	24-6549	A-17835	Laboratory Item
32	---	A-21379	Crate Center Left	62	24-6549	A-17835	Crate Item
33	---	A-21379	Crate Center Right	63	24-6549	A-17835	Skull Item
34	---	A-21379	Crate Right Eye	64	24-8768	A-21302	*Web Award 2
35	24-6549	A-17835	Left Outlane	65	24-8768	A-21302	*Web Award 3
36	24-8768	A-21288	Right Leaper	66	24-8768	A-21302	*Web Award 4
37	24-8768	A-21288	Right Ramp Jackpot	67	24-8768	A-21302	*Web Award 5
38	24-8768	A-21288	Light Spin Spider	68	24-8768	A-21302	*Web Award 6

\* Located in backbox

# Lamp Locations (continued)

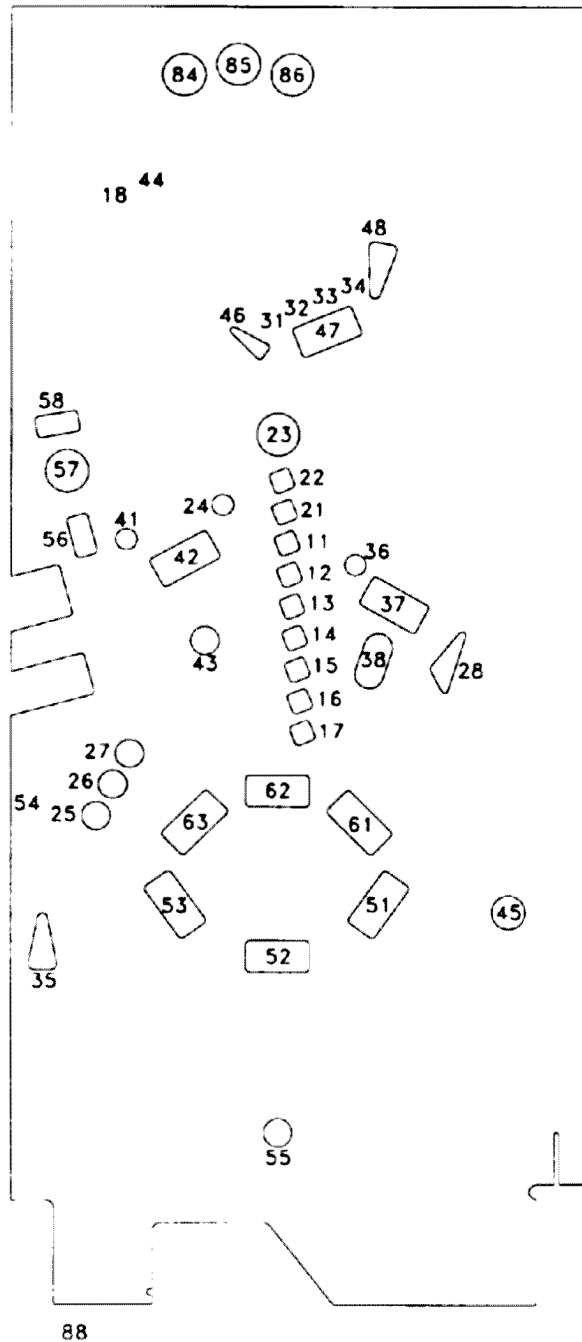

Item No.	Bulb No.	Lamp Assy. No.	Description
71	24-8768	A-21305	*Web Award 7
72	24-8768	A-21305	*Web Award 8
73	24-8768	A-21305	*Web Award 9
74	24-8768	A-21303	*Web Award 10
75	24-8768	A-21303	*Web Award 11
76	24-8768	A-21303	*Web Award 12
77	24-8768	A-21303	*Web Award 13
78	24-8768	A-21303	*Web Award 14
81	24-8768	A-21304	*Web Award 15
82	24-8768	A-21304	*Web Award 16

Item No.	Bulb No.	Lamp Assy. No.	Description
83	24-8768	A-21304	*Web Award 1
84	24-8768	A-21305	Left Skull Lane
85	24-8768	A-21305	Center Skull Lane
86	24-8768	A-21305	Right Skull Lane
87	---	---	Buy-In (Option)
88	---	20-9663-16	Start Button

\* Located in backbox  
 24-8768 = #555 Bulb  
 24-6549 = #44 Bulb

# SWITCH MATRIX

White Green

Dedicated Grounded Switches	Column										Flipper Grounded Switches
	Row	1 Green-Brown J206-1 U20-18	2 Green-Red J206-2 U20-17	3 Green-Orange J206-3 U20-16	4 Green-Yellow J206-4 U20-15	5 Green-Black J206-5 U20-14	6 Green-Blue J206-6 U20-13	7 Green-Violet J206-7 U20-12	8 Green-Gray J206-9 U20-11		
Orange-Brown J205-1 U17-6 Left Coin Chute D1	1 White-Brown J208-1 U18-11	NOT USED	SLAM TILT	TROUGH EJECT	COFFIN LEFT	LEFT SLUNGSHOT	THREE BANK UPPER	LEFT SKULL LANE	NOT USED	Black-Green J208-13 Lower Right Flipper EOS F1	
Orange-Red J205-2 U17-7 Center Coin Chute D2	2 White-Red J208-2 U18-9	WHEEL INDEX	COIN DOOR CLOSED	TROUGH BALL 1	COFFIN CENTER	RIGHT SLUNGSHOT	THREE BANK MIDDLE	CENTER SKULL LANE	NOT USED	Blue-Violet J212-12 Lower Right Flipper Opto F2	
Orange-Black J205-3 U17-11 Right Coin Chute D3	3 White-Orange J208-3 U18-5	START BUTTON	BUY IN BUTTON	TROUGH BALL 2	COFFIN RIGHT	UPPER JET	THREE BANK LOWER	RIGHT SKULL LANE	NOT USED	Black-Blue J208-12 Lower Left Flipper EOS F3	
Orange-Yellow J205-4 U17-9 4th Coin Chute D4	4 White-Yellow J208-4 U18-7	PLUMB BOB TILT	ALWAYS CLOSED	TROUGH BALL 3	LEFT RAMP ENTER	CENTER JET	LEFT LEAPER	SECRET PASSAGE	NOT USED	Blue-Gray J212-11 Lower Left Flipper Opto F4	
Orange-Green J205-6 U16-9 Normal Function Ser Credits Test Function Esc D5	5 White-Green J208-5 U19-11	NOT USED	EXTRA BALL LANE	TROUGH BALL 4	RIGHT RAMP ENTER	LOWER JET	CENTER LEAPER	NOT USED	NOT USED	Black-Violet J208-11 Upper Right Flipper EOS F5	
Orange-Blue J205-7 U16-11 Normal Function Vol Down Test Function Down D6	6 White-Blue J208-7 U19-9	KICKBACK	LEFT FLIPPER LANE	RIGHT POPPER	LEFT RAMP MADE	UPPER SLUNGSHOT	RIGHT LEAPER	NOT USED	NOT USED	Black-Yellow J212-10 Upper Right Flipper Opto F6	
Orange-Violet J205-8 U16-7 Normal Function Vol Up Test Function Up D7	7 White-Violet J208-8 U19-5	RIGHT FLIPPER LANE	RIGHT OUTLANE	LEFT KICKOUT	RIGHT RAMP MADE	CRATE SENSOR	LEFT RAMP POINT 10	NOT USED	NOT USED	Black-Gray J208-10 Upper Left Flipper EOS F7	
Orange-Gray J205-9 U16-5 Normal Function Begin Test Test Function Enter D8	8 White-Gray J208-9 U19-7	SHOOTER LANE	SINGLE STANDUP	CRATE ENTRANCE	COFFIN ENTRANCE	LEFT LOOP	RIGHT LOOP	NOT USED	NOT USED	Black-Blue J212-9 Upper Left Flipper Opto F8	

J2XX = CPU Board;

= Opto, Typically Closed

## SWITCH LOCATIONS

Item No. Switch Part No.

F1	SW-1A-194	Lower Right Flipper EOS
F2	A-17316	*Lower Right Flipper Cabinet
F3	SW-1A-194	Lower Left Flipper EOS
F4	A-17316	*Lower Left Flipper Cabinet
F5	---	Not Used
F6	---	Not Used
F7	---	Not Used
F8	---	Not Used
11	---	Not Used
12	D-12046	*Wheel Index
13	20-9663-16	Start Button
14	04-10346	*Plumb Bob Tilt
15	---	Not Used
16	5647-12693-19	Kickback
17	5647-12693-19	Right Flipper Lane
18	5647-12693-65	Shooter Lane
21	A-17195	*Slam Tilt
22	5643-09288-00	*Coin Door Closed
23	---	Buy-In Button (Option)
24	5643-09112-00	*Always Closed
25	5647-12693-19	Extra Ball Lane
26	5647-12693-19	Left Flipper Lane
27	5647-12693-19	Right Outlane
28	A-12912-23	Single Standup
31	A-18617-1	Trough Eject (LED)
	A-18618-1	(Trans.)

\*Not Shown

† Located Under Playfield

Item No. Switch Part No.

32	A-18617-1	Trough Ball 1 (LED)
	A-18618-1	(Trans.)
33	A-18617-1	Trough Ball 2 (LED)
	A-18618-1	(Trans.)
34	A-18617-1	Trough Ball 3 (LED)
	A-18618-1	(Trans.)
35	A-18617-1	Trough Ball 4 (LED)
	A-18618-1	(Trans.)
36	A-16908	Right Popper (LED)
	A-16909	(Trans.)
37	A-16908	Left Kickout (LED)
	A-16909	(Trans.)
38	A-16908	Crate Entrance (LED)
	A-16909	(Trans.)
41	A-16908	Coffin Left (LED)
	A-16909	(Trans.)
42	A-16908	Coffin Center (LED)
	A-16909	(Trans.)
43	A-16908	Coffin Right (LED)
	A-16909	(Trans.)
44	A-16908	Left Ramp Enter (LED)
	A-16909	(Trans.)
45	A-16908	Right Ramp Enter (LED)
	A-16909	(Trans.)
46	A-16908	Left Ramp Made (LED)
	A-16909	(Trans.)

## Switch Locations (continued)

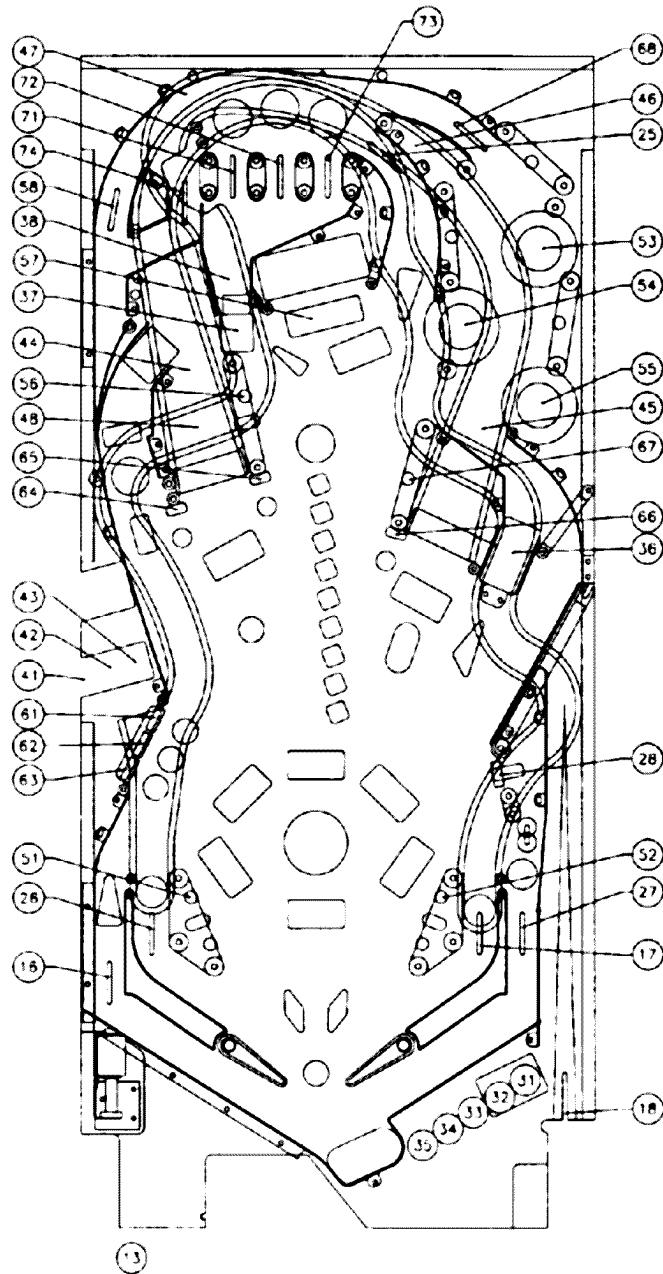

Item No.	Switch Part No.	Description
47	A-16908	Right Ramp Made (LED)
	A-16909	(Trans.)
48	A-16908	Coffin Entrance (LED)
	A-16909	(Trans.)
51	SW-1A-114	Left Slingshot (Kicker)
	SW-1A-120	(Score)
52	SW-1A-114	Right Slingshot (Kicker)
	SW-1A-120	(Score)
53	SW-11A-37	Upper Jet
54	SW-11A-37	Center Jet
55	SW-11A-37	Lower Jet
56	SW-1A-120	Upper Slingshot
57	A-19237	Crate Sensor
58	5647-12693-19	Left Loop

Item No.	Switch Part No.	Description
61	A-12912-23	Three Bank Upper
62	A-12912-23	Three Bank Middle
63	A-12912-23	Three Bank Lower
64	A-20783-7	Left Leaper
65	A-20783-7	Center Leaper
66	A-20783-7	Right Leaper
67	SW-1A-120	Left Ramp 10 Point
68	5647-12693-19	Right Loop
71	5647-12693-19	Left Skull Lane
72	5647-12693-19	Center Skull Lane
73	5647-12693-19	Right Skull Lane
74	5647-12693-19	Secret Passage
75-88	---	Not Used

\*Not Shown

## SOLENOID/FLASHER TABLE

Sol. No.	Function	Solenoid Type	Voltage Connections			Drive Xister	Drive Connections			Drive Wire Color	Solenoid Part number	
			Playfield	Backbox	Cabinet		Playfield	Backbox	Cabinet		Flashlamp Type	Backbox
01	AUTO PLUNGER	High Power	J133-2			Q72	J116-1			Vio-Brn	AE-23-800	
02	LOOP GATE	High Power	J133-2			Q68	J116-2			Vio-Red	A-14406	
03	RIGHT POPPER	High Power	J133-2			Q71	J116-4			Vio-Org	AE-24-900	
04	COFFIN POPPER	High Power	J133-2			Q67	J116-5			Vio-Yel	AE-23-800	
05	COFFIN DOOR	High Power	J133-2			Q70	J116-6			Vio-Grn	AE-26-1500	
06	CRATE KICKOUT	High Power	J133-2			Q66	J116-7			Vio-Blu	AE-24-900	
07	*KNOCKER	High Power		J133-2		Q69		J116-8		Vio-Blk		AE-23-800
08	CRATE POST POWER	High Power	J133-2			Q65	J116-9			Vio-Gry	FL-11629	
09	TROUGH EJECT	Low Power	J133-3			Q44	J113-1			Brn-Blk	AE-26-1500	
10	LEFT SLING	Low Power	J133-3			Q48	J113-3			Brn-Red	AE-25-1000	
11	RIGHT SLING	Low Power	J133-3			Q43	J113-4			Brn-Org	AE-25-1000	
12	CENTER JET	Low Power	J133-3			Q47	J113-5			Brn-Yel	AE-26-1200	
13	UPPER JET	Low Power	J133-3			Q42	J113-6			Brn-Grn	AE-26-1200	
14	LOWER JET	Low Power	J133-3			Q46	J113-7			Brn-Blu	AE-26-1200	
15	UPPER SLINGSHOT	Low Power	J133-3			Q41	J113-8			Brn-Vio	AE-26-1200	
16	CRATE POST HOLD	Low Power	J133-2			Q45	J113-9			Brn-Gry	FL-11629	
17	TOP JET FLASHER	Flasher	J133-6	J134-5		Q28	J111-1	J112-1		Blk-Brn	24-8802	24-8704
18	MIDDLE JET FLASHER	Flasher	J133-6	J134-5		Q32	J111-2	J112-2		Blk-Red	24-8802	24-8704
19	LOWER JET FLASHER	Flasher	J133-6	J134-5		Q27	J111-3	J112-3		Blk-Org	24-8802	24-8704
20	PLAYFIELD BOLTS	Flasher	J133-6			Q31	J111-4			Blk-Yel	24-8704 (2)	
21	SKULL FLASHER LEFT	Flasher	J133-6			Q26	J111-5			Blu-Grn	24-8802	
22	UPPER RIGHT FLASHER	Flasher	J133-6			Q30	J111-6			Blu-Blk	24-8802	
23	LEFT RAMP FLASHER	Flasher	J133-6			Q25	J111-7			Blu-Vio	24-8802	
24	CENTER LEFT FLASHER	Flasher	J133-6			Q29	J111-8			Blu-Gry	24-8802	
25	SKULL FLASHER RIGHT	Gen. Purpose	J133-6			Q16	J109-1			Blu-Brn	24-8802	
26	CENTER TV	Gen. Purpose	J133-6	J134-5		Q15	J109-2	J107-3		Blu-Red	24-8802	
27	UPPER LEFT FLASHER	Gen. Purpose	J133-6			Q14	J109-3			Blu-Org	24-8802	
28	CENTER RIGHT FLASHER	Gen. Purpose	J133-6			Q13	J109-4			Blu-Yel	24-8802	
33	LEFT DIVERTER POWER	High Power	J119-6,7			Q84	J120-6			Yel-Vio	A-20099	
34	LEFT DIVERTER HOLD	Low Power	J119-6,7			Q86	J120-4			Org-Vio	A-20099	
35	LOWER LEFT FLASHER	High Power	J133-6			Q81	J120-3			Yel-Gry	24-8802	
36	LOWER RIGHT FLASHER	Low Power	J133-6			Q83	J120-1			Org-Gry	24-8802	
37	**AUX LAMP CLOCK	oL P.D.C.	J141-2				J110-1			Brn-Wht	A-20781	
38	**AUX LAMP DATA	oL P.D.C.	J141-2				J110-3			Org-Wht	A-20781	
39	*SPIDER WHEEL 1 (1.8V)	oL P.D.C.		J141-2				J110-4		Yel-Wht		14-8024
40	*SPIDER WHEEL 2 (1.8V)	oL P.D.C.		J141-2				J110-5		Grn-Wht		14-8024

### General Illumination

01	UPPER PLAYFIELD	G.I.	J105-1			Q5	J105-7			Wht-Brn	24-6549	
02	CENTER PLAYFIELD	G.I.	J105-2			Q4	J105-8			Wht-Org	24-6549	
03	LOWER PLAYFIELD	G.I.	J105-3			Q3	J105-9			Wht-Yel	24-6549	
04	↑ ILLUM. STRING 4	G.I.		J106-7		Q2		J106-10		Wht-Grn		24-6549
05	↑ ILLUM. STRING 5	G.I.		J106-6		Q1		J106-11		Wht-Vio		24-6549

### Flipper Circuits

No.	Coil/ Flasher No.	Assy. Number	Description	Voltage Connections		Drive Transistors		Drive Connectors		Drive Wire Colors		Coil Part No.	Coil Color
				Playfield	Backbox	Power	Hold	Playfield	Backbox	Power	Hold		
29				Lwr. Rt. Power	J119-1 (Red-Grn)	Q90		J120-13		Yel-Grn			
30	Lower Right Flipper			Lwr. Rt. Hold	J119-1 (Red-Grn)		Q92	J120-11		Org-Grn	FL-11629		BLUE
31				Lwr. Lt. Power	J119-4 (Red-Blu)	Q87		J120-9		Yel-Blu			
32	Lower Left Flipper			Lwr. Lt. Hold	J119-4 (Red-Blu)		Q89	J120-7		Org-Blu	FL-11629		BLUE
33				Upr. Rt. Power	J119-6 (Red-Vio)	Q84		J120-6		Yel-Vio	SEE		ABOVE
34	Upper Right Flipper			Upr. Rt. Hold	J119-6 (Red-Vio)		Q86	J120-4		Org-Vio	SEE		ABOVE
35				Upr. Lt. Power	J119-8 (Red-Gry)	Q81		J120-3		Yel-Gry	SEE		ABOVE
36	Upper Left Flipper			Upr. Lt. Hold	J119-8 (Red-Gry)		Q83	J120-1		Org-Gry	SEE		ABOVE

J1xx = Power Driver Board; 24-6549=#44 bulb; 24-8704=#89 bulb; 24-8768=#555 bulb; 24-8802=#906 bulb; oL P.D.C. = Low Power Device Controls

↑ These G.I. strings do not brighten and dim, they are always ON. \* Located in Backbox \*\* Located under playfield

## SOLENOID/FLASHER LOCATIONS

Item No.	Coil/ Flasher No.	Assy. Number	Description	Item No.	Coil/ Flasher No.	Assy. Number	Description
01	AE-23-800	A-21022	AUTO PLUNGER	09	AE-26-1500	A-19963-1	TROUGH EJECT
02	A-14406	A-17796	LOOP GATE	10	AE-25-1000	B-9362-L-4	LEFT SLING
03	AE-24-900	A-20716	RIGHT POPPER	11	AE-25-1000	B-9362-R-5	RIGHT SLING
04	AE-23-800	A-20717	COFFIN POPPER	12	AE-26-1200	A-9415-2	CENTER JET
05	AE-26-1500	A-20717	COFFIN DOOR	13	AE-26-1200	A-9415-2	UPPER JET
06	AE-24-900	A-20788	CRATE KICKOUT	14	AE-26-1200	A-9415-2	LOWER JET
07	AE-23-800	B-10686-1	*KNOCKER	15	AE-26-1200	A-21333	UPPER SLINGSHOT
08	FL-11629	A-20850	CRATE POST POWER	16	FL-11629	A-20850	CRATE POST HOLD

# Solenoid/Flasher Locations (continued)

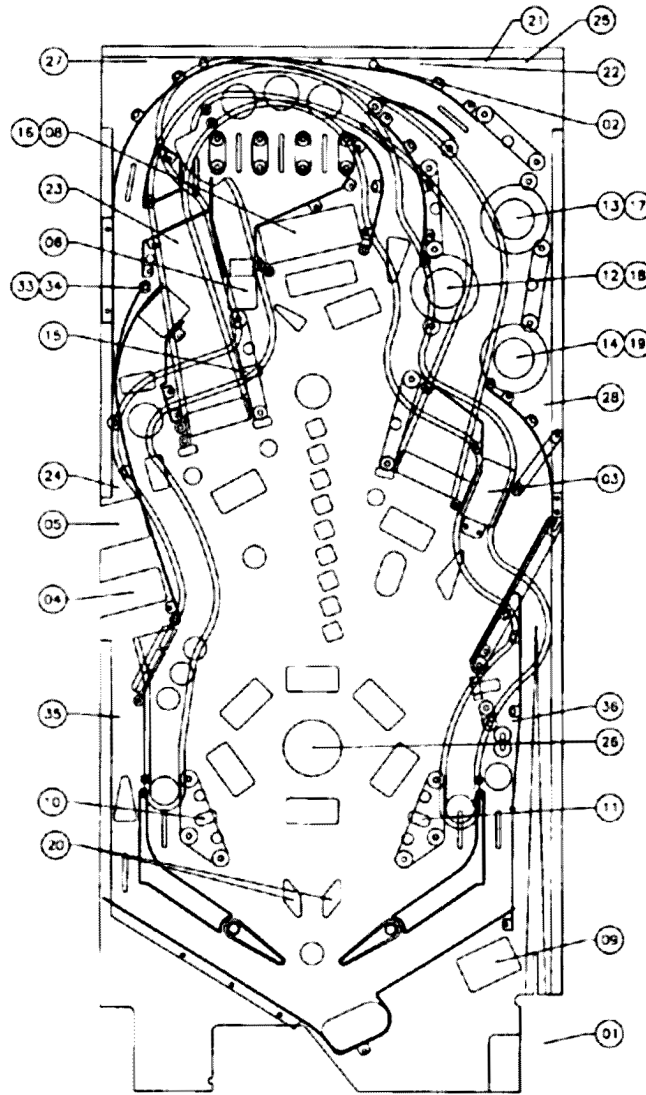

Item No.	Coil/Flasher No.	Assy. Number.	Description
17	24-8802	A-20432-6	TOP JET FLASHER
	24-8704	A-17984	
18	24-8802	A-20432-6	MIDDLE JET FLASHER
	24-8704	A-17983	
19	24-8802	A-20432-6	LOWER JET FLASHER
	24-8704	A-17984	
20	24-8704	A-17984	PLAYFIELD BOLTS
21	24-8802	A-20158	SKULL FLASHER LEFT
22	24-8802	04-10511	UPPER RIGHT FLASHER
23	24-8802	A-17802	LEFT RAMP FLASHER
24	24-8802	04-10511	CENTER LEFT FLASHER
25	24-8802	A-20158	SKULL FLASHER RIGHT
26	24-8704	A-17803	CENTER TV
	24-8704	A-17983	
27	24-8802	04-10511	UPPER LEFT FLASHER
28	24-8802	04-10511	CENTER RIGHT FLASHER
33	A-20099	A-20769	LEFT DIVERTER POWER
34	A-20099	A-20769	LEFT DIVERTER HOLD
35	24-8802	04-10511	LOWER LEFT FLASHER
36	24-8802	04-10511	LOWER RIGHT FLASHER
37	---	A-20781	**AUX LAMP CLOCK
38	---	A-20781	**AUX LAMP DATA
39	14-8024	A-21248	*SPIDER WHEEL 1 (1.8V)
40	14-8024	A-21248	*SPIDER WHEEL 2 (1.8V)

### General Illumination Circuits

Item No.	Description	Bulb No.	
01	UPPER PLAYFIELD	24-6549	G.I. STRING 1
02	CENTER PLAYFIELD	24-6549	G.I. STRING 2
03	LOWER PLAYFIELD	24-6549	G.I. STRING 3
04	ILLUM. STRING 4	24-6549	G.I. STRING 4
05	ILLUM. STRING 5	24-6549	G.I. STRING 5

### Flipper Coils

Item No.	Coil No.	Color	Assy. No.	Description
29 & 30	FL-11629	BLUE	A-14876-R-3	LOWER R FLIPPER
31 & 32	FL-11629	BLUE	A-15849-L-2	LOWER L FLIPPER

\* Located in backbox

\*\* Located under playfield





# SECTION THREE

## GAME WIRING AND SCHEMATICS

### CONNECTOR & COMPONENT IDENTIFICATION

Each plug or jack receives a number that identifies the circuit board and the position on that board that it connects to. J-designations refer to a male connector. P-designations refer to a female connector. For example, J101 designates jack 1 of board 1 (a Power Driver board jack); P206 designates plug 6 of board 2 (a CPU board plug). Identifying the specific pin number of a connector involves a hyphen, which separates the pin number from the plug or jack designation. For example, J101-3 refers to pin 3 of jack 1 on board 1.

Other game components may also have similar numbers to clarify their locations or related circuits. For example, F501 is a fuse on the Audio Video board.

Prefix numbers for WPC circuit boards are listed below.

J1XX - Power Driver board jacks; F1XX - Power Driver board fuses.

J2XX - CPU Board (There are no fuses on the CPU board.)

J5XX and J6XX - Audio Video board (AV board) jacks; F5XX and F6XX - Audio Video board fuses.

**Schematics for standard WPC backbox boards are found in the WPC Schematics Manual. Playfield, cabinet and all other backbox board schematics are found in this section.**

# SWITCH MATRIX

Dedicated Grounded Switches	Column Row	1	2	3	4	5	6	7	8	Flipper Grounded Switches
		Green-Brown J206-1 U20-18	Green-Red J206-2 U20-17	Green-Orange J206-3 U20-16	Green-Yellow J206-4 U20-15	Green-Black J206-5 U20-14	Green-Blue J206-6 U20-13	Green-Violet J206-7 U20-12	Green-Gray J206-9 U20-11	
Orange-Brown J205-1 U17-5 Left Coin Chute D1	1 White-Brown J208-1 U18-11	NOT USED 11	SLAM TILT 21	TROUGH EJECT 31	COFFIN LEFT 41	LEFT SLINGSHOT 51	THREE BANK UPPER 61	LEFT SKULL LANE 71	NOT USED 81	Black-Green J208-13 Lower Right Flipper EOS F1
Orange-Red J205-2 U17-7 Center Coin Chute D2	2 White-Red J208-2 U18-9	WHEEL INDEX 12	COIN DOOR CLOSED 22	TROUGH BALL 1 32	COFFIN CENTER 42	RIGHT SLINGSHOT 52	THREE BANK MIDDLE 62	CENTER SKULL LANE 72	NOT USED 82	Blue-Violet J212-12 Lower Right Flipper Opto F2
Orange-Black J205-3 U17-11 Right Coin Chute D3	3 White-Orange J208-3 U18-5	START BUTTON 13	BUY IN BUTTON 23	TROUGH BALL 2 33	COFFIN RIGHT 43	UPPER JET 53	THREE BANK LOWER 63	RIGHT SKULL LANE 73	NOT USED 83	Black-Blue J208-12 Lower Left Flipper EOS F3
Orange-Yellow J205-4 U17-9 4th Coin Chute D4	4 White-Yellow J208-4 U18-7	PLUMB BOB TILT 14	ALWAYS CLOSED 24	TROUGH BALL 3 34	LEFT RAMP ENTER 44	CENTER JET 54	LEFT LEAPER 64	SECRET PASSAGE 74	NOT USED 84	Blue-Gray J212-11 Lower Left Flipper Opto F4
Orange-Green J205-5 U16-9 Normal Function: Ser Credits Test Function: Esc D5	5 White-Green J208-5 U19-11	NOT USED 15	EXTRA BALL LANE 25	TROUGH BALL 4 35	RIGHT RAMP ENTER 45	LOWER JET 55	CENTER LEAPER 65	NOT USED 75	NOT USED 85	Black-Violet J208-11 Upper Right Flipper EOS F5 (NOT USED)
Orange-Blue J205-7 U16-11 Normal Function: Vol Down Test Function: Down D6	6 White-Blue J208-7 U19-9	KICKBACK 16	LEFT FLIPPER LANE 26	RIGHT POPPER 36	LEFT RAMP MADE 46	UPPER SLINGSHOT 56	RIGHT LEAPER 66	NOT USED 76	NOT USED 86	Black-Yellow J212-10 Upper Right Flipper Opto F6
Orange-Violet J205-8 U16-7 Normal Function: Vol Up Test Function: Up D7	7 White-Violet J208-8 U19-5	RIGHT FLIPPER LANE 17	RIGHT OUTLANE 27	LEFT KICKOUT 37	RIGHT RAMP MADE 47	CRATE SENSOR 57	LEFT RAMP 10 POINT 67	NOT USED 77	NOT USED 87	Black-Gray J208-10 Upper Left Flipper EOS F7 (NOT USED)
Orange-Gray J205-9 U16-5 Normal Function: Begin Test Test Function: Enter D8	8 White-Gray J208-9 U19-7	SHOOTER LANE 18	SINGLE STANDUP 28	CRATE ENTRANCE 38	COFFIN ENTRANCE 48	LEFT LOOP 58	RIGHT LOOP 68	NOT USED 78	NOT USED 88	Black-Blue J212-9 Upper Left Flipper Opto F8

J2XX = CPU Board;

□ = Opto, Typically Closed

## SWITCH MATRIX CIRCUIT

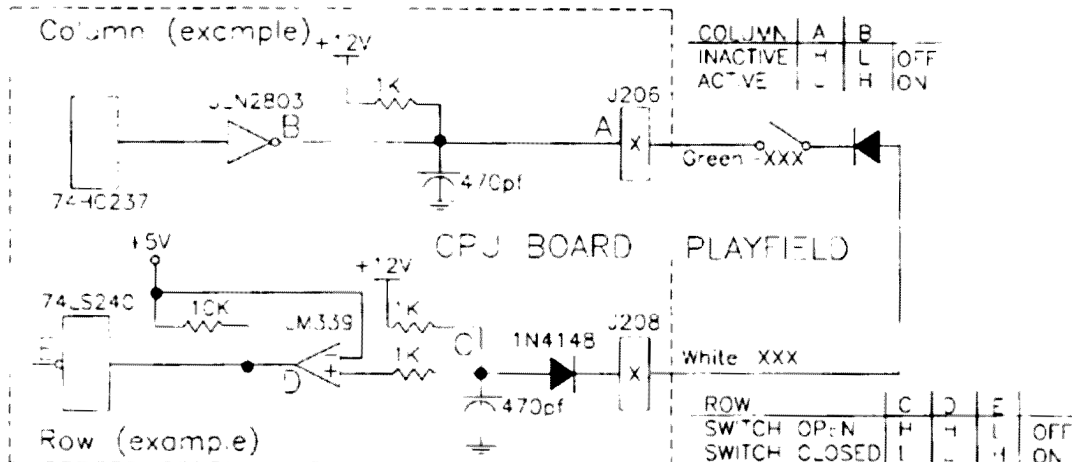

The microprocessor is constantly strobing the column side of the switch. When point "A" on the column circuit toggles low, the column side is active. When a switch closes, the row side of the circuit activates. The "+" input to the LM339 drops below +5V, therefore, its output is low. Corresponding row and column switches must be low at the same time for the switch to be considered closed by the microprocessor. When the switch opens, the "+" input to the LM339 is above +5V, its output is high and the row is inactive.

## DEDICATED SWITCHES

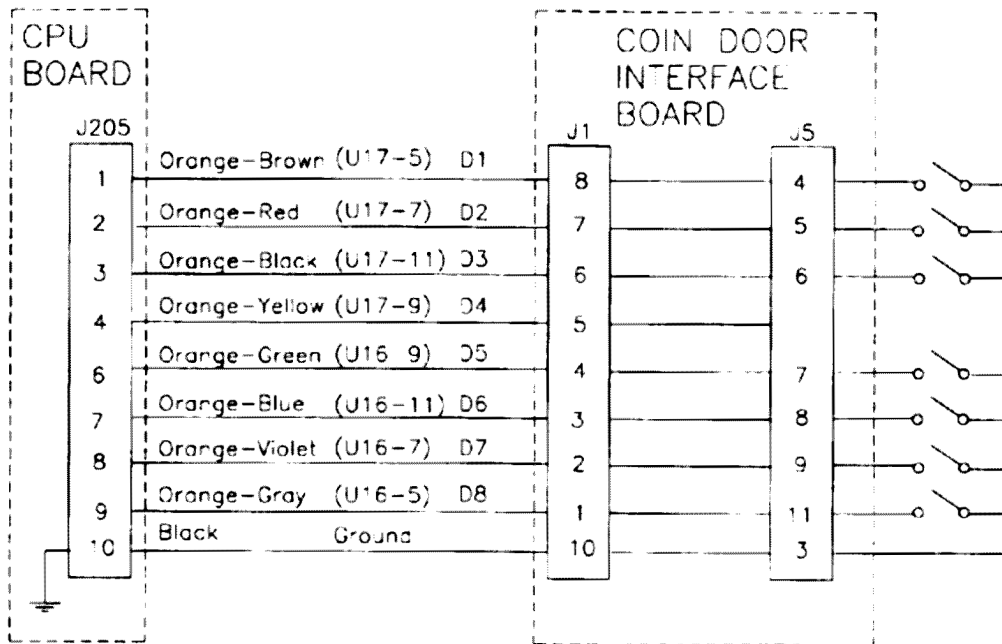

**Coin Acceptor Switches**  
 D1 - Left Coin Chute  
 D2 - Center Coin Chute  
 D3 - Right Coin Chute  
 D4 - Fourth Coin Chute

**Control Switches**  
 D5 - Normal Function, Service Credits; Test Function, Escape  
 D6 - Normal Function, Volume Down; Test Function, Down  
 D7 - Normal Function, Volume Up; Test Function, Up  
 D8 - Normal Function, Begin Test; Test Function, Enter

## DEDICATED SWITCH CIRCUIT

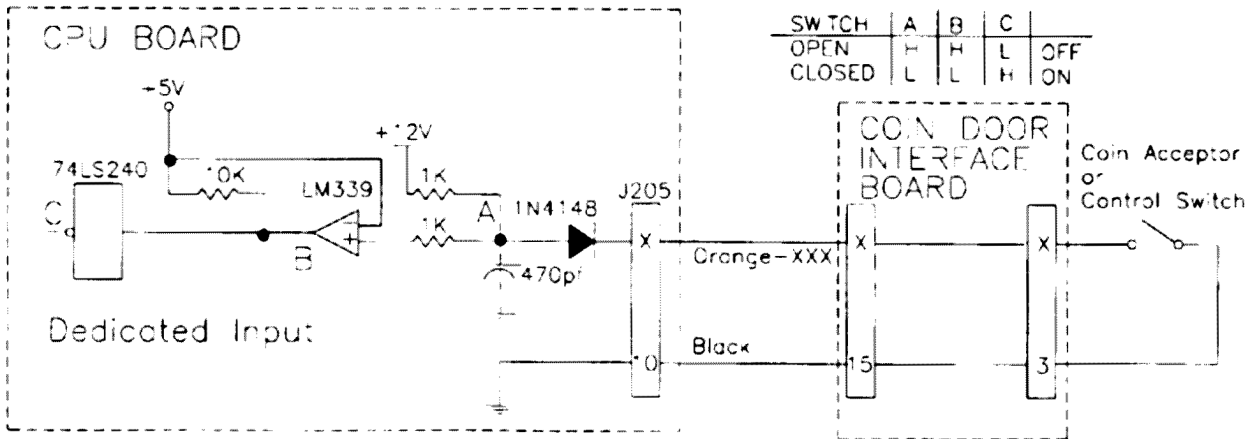

The dedicated switches operate similar in the matrix, except that instead of a column circuit there is a direct tie to ground. Therefore, the column side is constantly active (low). When a switch closes, the row side (dedicated input) of the circuit activates. The "+" input to the LM339 drops below +5V, therefore the output is low. Since the row circuit (dedicated input) is tied directly to ground through the switch, the switch is considered closed by the microprocessor. When the switch opens, the "+" input to the LM339 is above +5V, its output is high and the row is inactive.

# LAMP MATRIX

Column	1 Yellow-Brown J121-1 Q96	2 Yellow-Red J121-2 Q100	3 Yellow-Orange J121-3 Q95	4 Yellow-Black J121-4 Q99	5 Yellow-Green J121-5 Q94	6 Yellow-Blue J121-6 Q98	7 Yellow-Violet J121-7 Q93	8 Yellow-Gray J121-9 Q97
1 Red-Brown J125-1 Q104	STIFF LEVEL 7 11	STIFF LEVEL 8 21	CRATE LEFT EYE 31	LEFT LEAPER 41	RAMP ITEM 51	LABORATORY ITEM 61	WEB AWARD 7 71	WEB AWARD 15 81
2 Red-Black J125-2 Q108	STIFF LEVEL 6 12	STIFF LEVEL 9 22	CRATE CENTER LEFT 32	LEFT RAMP JACKPOT 42	COFFIN MULTIBALL ITEM 52	CRATE ITEM 62	WEB AWARD 8 72	WEB AWARD 16 82
3 Red-Orange J125-4 Q103	STIFF LEVEL 5 13	SCARED STIFF 23	CRATE CENTER RIGHT 33	LIGHT LOCK 43	LEAPER ITEM 53	SKULL ITEM 63	WEB AWARD 9 73	WEB AWARD 1 83
4 Red-Yellow J125-5 Q107	STIFF LEVEL 4 14	CENTER LEAPER 24	CRATE RIGHT EYE 34	RAMP RIGHT EYE 44	COFFIN SPOTLIGHT 54	WEB AWARD 2 64	WEB AWARD 10 74	LEFT SKULL LANE 84
5 Red-Green J125-6 Q102	STIFF LEVEL 3 15	THREE BANK LOWER 25	LEFT OUTLANE 35	RIGHT OUTLANE 45	SHOOT AGAIN 55	WEB AWARD 3 65	WEB AWARD 11 75	CENTER SKULL LANE 85
6 Red-Blue J125-7 Q106	STIFF LEVEL 2 16	THREE BANK MIDDLE 26	RIGHT LEAPER 36	SKILL SHOT 46	LOCK LAMP 56	WEB AWARD 4 66	WEB AWARD 12 76	RIGHT SKULL LANE 86
7 Red-Violet J125-8 Q101	STIFF LEVEL 1 17	THREE BANK UPPER 27	RIGHT RAMP JACKPOT 37	CRATE JACKPOT 47	LEFT LOOP CENTER 57	WEB AWARD 5 67	WEB AWARD 13 77	BUY IN 87
8 Red-Gray J125-9 Q105	RAMP LEFT EYE 18	SPIDER POPPER 28	LIGHT SPIN SPIDER 38	EXTRA BALL 48	LEFT LOOP UPPER 58	WEB AWARD 6 68	WEB AWARD 14 78	START BUTTON 88

J1XX = Power Driver Board

## LAMP MATRIX CIRCUIT

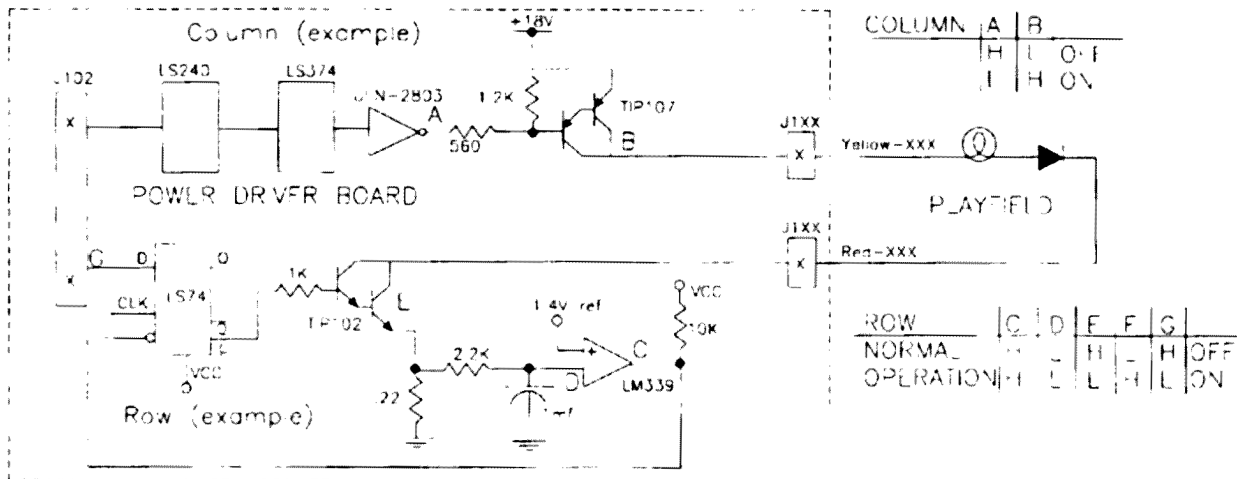

The microprocessor sends a signal to the column circuit causing the output of the UNL-2803 to toggle. When point "A" drops low, the TIP107 transistor conducts and point "B" changes to a high state. At the same time, the microprocessor drives the input of the 74LS74 low, causing a high at output "F". A high state at the base of the TIP102 causes the transistor to conduct, bringing the row circuit to ground and turning the lamp on. The microprocessor changes the input of the 74LS74 to a high state to turn the lamp off. In over-current conditions, the lamp is shut off through the comparator. If the voltage at the negative input of the LM339 rises above 1.4V, the output changes to a low, which is fed back to the 74LS74 and shuts the circuit off.

# SOLENOID/FLASHER TABLE

Sol. No.	Function	Solenoid Type	Voltage Connections			Drive Xlster	Drive Connections			Drive Wire Color	Solenoid Part number Flashlamp Type	
			Playfield	Backbox	Cabinet		Playfield	Backbox	Cabinet		Playfield	Backbox
01	AUTO PLUNGER	High Power	J133-2			Q72	J116-1			Vio-Brn	AE-23-800	
02	LOOP GATE	High Power	J133-2			Q68	J116-2			Vio-Red	A-14406	
03	RIGHT POPPER	High Power	J133-2			Q71	J116-4			Vio-Org	AE-24-900	
04	COFFIN POPPER	High Power	J133-2			Q67	J116-5			Vio-Yel	AE-23-800	
05	COFFIN DOOR	High Power	J133-2			Q70	J116-6			Vio-Grn	AE-26-1500	
06	CRATE KICKOUT	High Power	J133-2			Q66	J116-7			Vio-Blu	AE-24-900	
07	*KNOCKER	High Power		J133-2		Q69		J116-8		Vio-Blk		AE-23-800
08	CRATE POST POWER	High Power	J133-2			Q65	J116-9			Vio-Gry	FL-11629	
09	TROUGH EJECT	Low Power	J133-3			Q44	J113-1			Brn-Blk	AE-26-1500	
10	LEFT SLING	Low Power	J133-3			Q48	J113-3			Brn-Red	AE-25-1000	
11	RIGHT SLING	Low Power	J133-3			Q43	J113-4			Brn-Org	AE-25-1000	
12	CENTER JET	Low Power	J133-3			Q47	J113-5			Brn-Yel	AE-26-1200	
13	UPPER JET	Low Power	J133-3			Q42	J113-6			Brn-Grn	AE-26-1200	
14	LOWER JET	Low Power	J133-3			Q46	J113-7			Brn-Blu	AE-26-1200	
15	UPPER SLINGSHOT	Low Power	J133-3			Q41	J113-8			Brn-Vio	AE-26-1200	
16	CRATE POST HOLD	Low Power	J133-2			Q45	J113-9			Brn-Gry	FL-11629	
17	TOP JET FLASHER	Flasher	J133-6	J134-5		Q28	J111-1	J112-1		Blk-Brn	24-8802	24-8704
18	MIDDLE JET FLASHER	Flasher	J133-6	J134-5		Q32	J111-2	J112-2		Blk-Red	24-8802	24-8704
19	LOWER JET FLASHER	Flasher	J133-6	J134-5		Q27	J111-3	J112-3		Blk-Org	24-8802	24-8704
20	PLAYFIELD BOLTS	Flasher	J133-6			Q31	J111-4			Blk-Yel	24-8704 (2)	
21	SKULL FLASHER LEFT	Flasher	J133-6			Q26	J111-5			Blu-Grn	24-8802	
22	UPPER RIGHT FLASHER	Flasher	J133-6			Q30	J111-6			Blu-Blk	24-8802	
23	LEFT RAMP FLASHER	Flasher	J133-6			Q25	J111-7			Blu-Vio	24-8802	
24	CENTER LEFT FLASHER	Flasher	J133-6			Q29	J111-8			Blu-Gry	24-8802	
25	SKULL FLASHER RIGHT	Gen. Purpose	J133-6			Q16	J109-1			Blu-Brn	24-8802	
26	CENTER TV	Gen. Purpose	J133-6	J134-5		Q15	J109-2	J107-3		Blu-Red	24-8802	24-8704
27	UPPER LEFT FLASHER	Gen. Purpose	J133-6			Q14	J109-3			Blu-Org	24-8802	
28	CENTER RIGHT FLASHER	Gen. Purpose	J133-6			Q13	J109-4			Blu-Yel	24-8802	
33	LEFT DIVERter POWER	High Power	J119-6,7			Q84	J120-6			Yel-Vio	A-20099	
34	LEFT DIVERter HOLD	Low Power	J119-6,7			Q86	J120-4			Org-Vio	A-20099	
35	LOWER LEFT FLASHER	High Power	J133-6			Q81	J120-3			Yel-Gry	24-8802	
36	LOWER RIGHT FLASHER	Low Power	J133-6			Q83	J120-1			Org-Gry	24-8802	
37	**AUX LAMP CLOCK	oL.P.D.C.	J141-2				J110-1			Brn-Wht	A-20781	
38	**AUX LAMP DATA	oL.P.D.C.	J141-2				J110-3			Org-Wht	A-20781	
39	*SPIDER WHEEL 1 (1.8V)	oL.P.D.C.		J141-2				J110-4		Yel-Wht		14-8024
40	*SPIDER WHEEL 2 (1.8V)	oL.P.D.C.		J141-2				J110-5		Grn-Wht		14-8024
<b>General Illumination</b>												
01	UPPER PLAYFIELD	G.I.	J105-1			Q5	J105-7			Wht-Brn	24-6549	
02	CENTER PLAYFIELD	G.I.	J105-2			Q4	J105-8			Wht-Org	24-6549	
03	LOWER PLAYFIELD	G.I.	J105-3			Q3	J105-9			Wht-Yel	24-6549	
04	† ILLUM. STRING 4	G.I.		J106-7		Q2		J106-10		Wht-Grn		24-6549
05	* ILLUM. STRING 5	G.I.		J106-6		Q1		J106-11		Wht-Vio		24-6549
<b>Flipper Circuits</b>												
		Voltage Connections	Drive Transistors		Drive Connectors	Drive Wire Colors		Coil Part No.	Coil Color			
			Playfield	Power Hold		Playfield	Power Hold					
29	Lower Right Flipper	Lwr. Rt. Power	J119-1 (Red-Grn)	Q90		J120-13	Yel-Grn	FL-11629	BLUE			
30		Lwr. Rt. Hold	J119-1 (Red-Grn)		Q92		J120-11			Org-Grn		
31	Lower Left Flipper	Lwr. Lt. Power	J119-4 (Red-Blu)	Q87		J120-9	Yel-Blu	FL-11629	BLUE			
32		Lwr. Lt. Hold	J119-4 (Red-Blu)		Q89		J120-7			Org-Blu		
33	Upper Right Flipper	Upr. Rt. Power	J119-6 (Red-Vio)	Q84		J120-6	Yel-Vio	SEE	ABOVE			
34		Upr. Rt. Hold	J119-6 (Red-Vio)		Q86		J120-4			Org-Vio		
35	Upper Left Flipper	Upr. Lt. Power	J119-8 (Red-Gry)	Q81		J120-3	Yel-Gry	SEE	ABOVE			
36		Upr. Lt. Hold	J119-8 (Red-Gry)		Q83		J120-1			Org-Gry		

J1xx = Power Driver Board; 24-6549=#44 bulb; 24-8704=#89 bulb; 24-8768=#555 bulb; 24-8802=#906 bulb; oL.P.D.C. = Low Power Device Controls  
 † These G.I. strings do not brighten and dim, they are always ON \* Located in Backbox \*\* Located under playfield

# SOLENOID WIRING

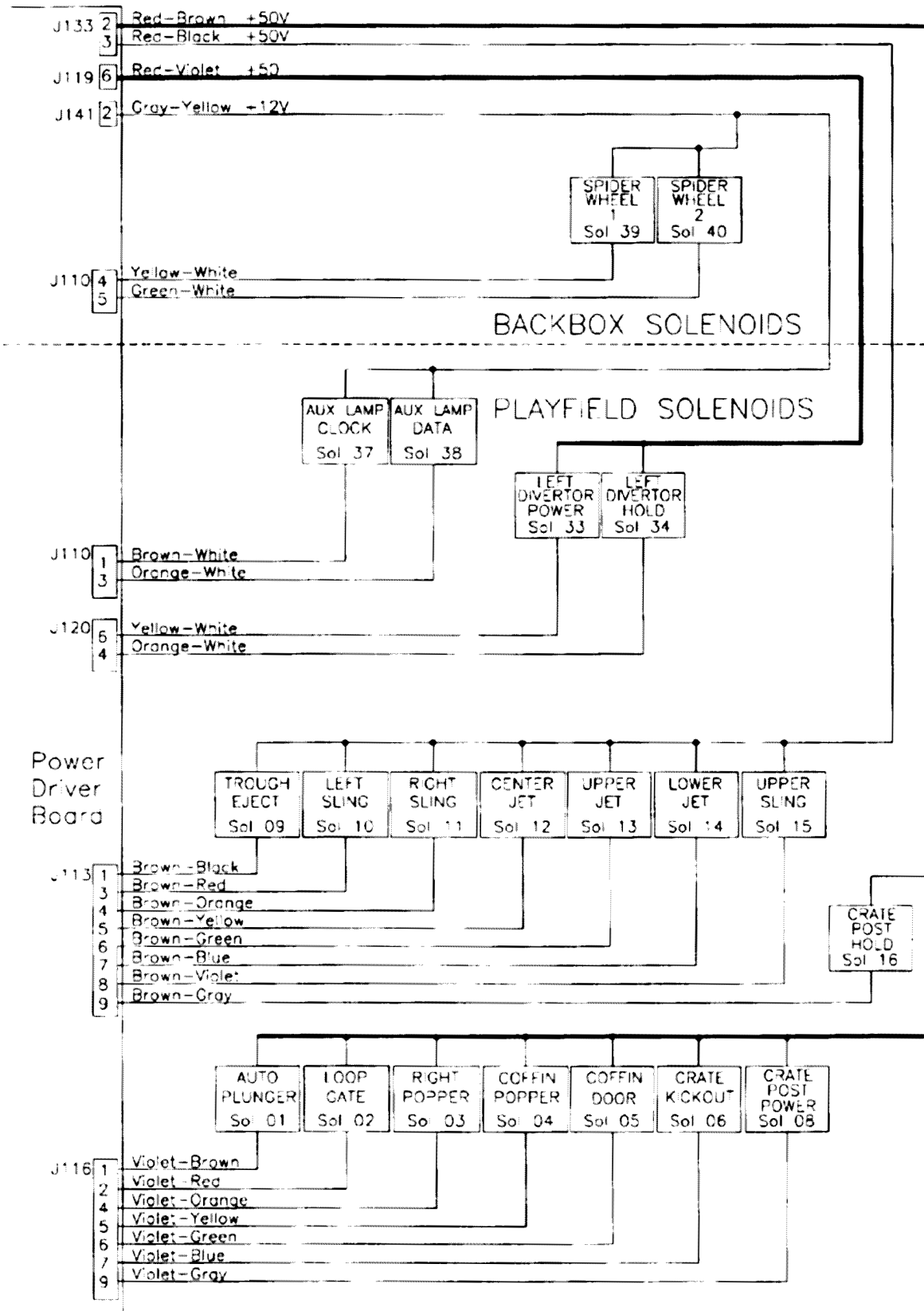

# FLASHER WIRING

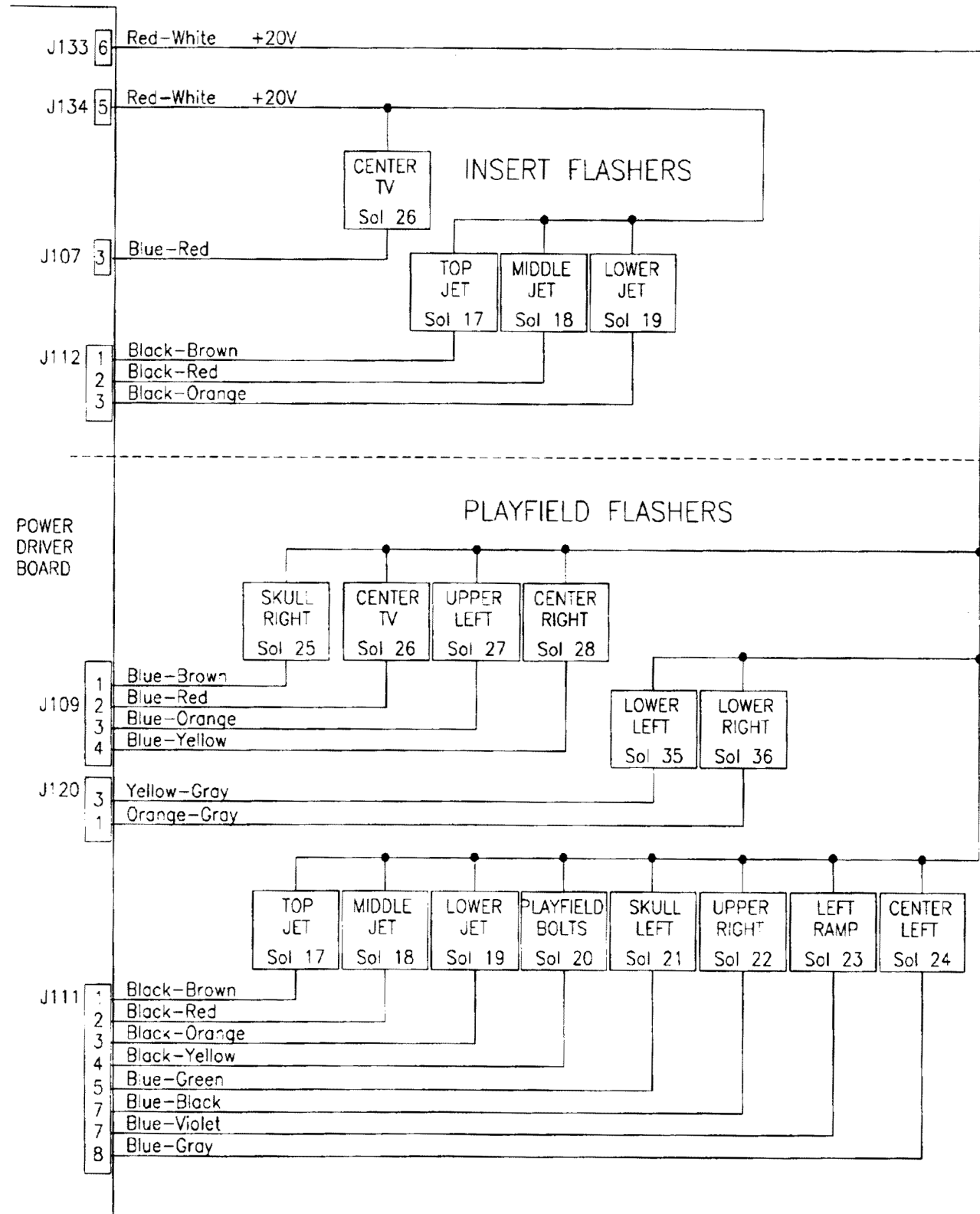



## HIGH POWER SOLENOID CIRCUIT

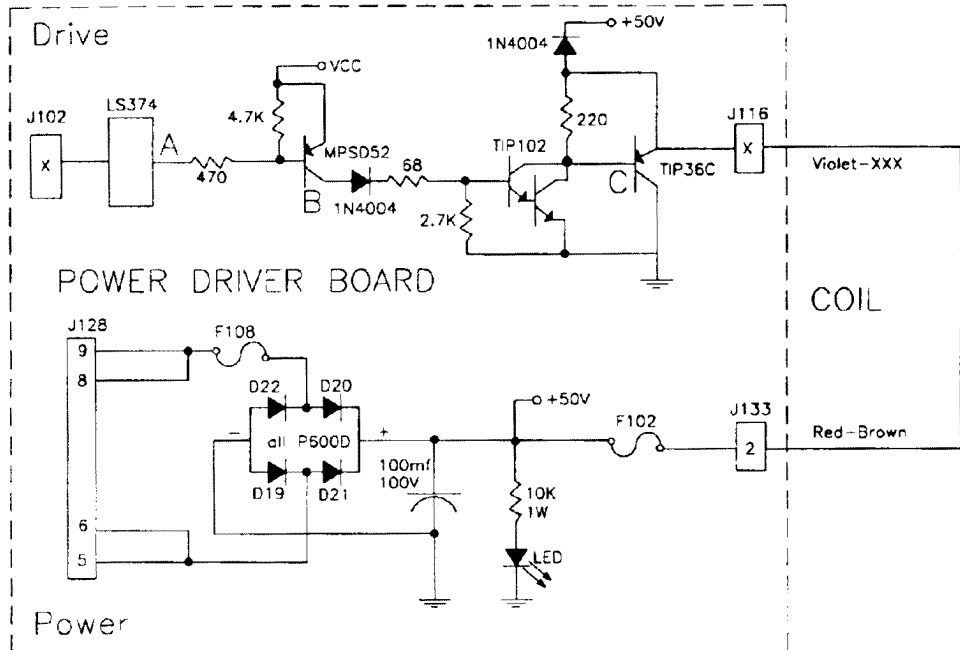

The microprocessor toggles the output of the 74LS374. When point "A" is low, point "B", the collector of the 2N5401 transistor, is high. A high at point "B" causes point "C", the collector of the TIP102 transistor and point "D", the emitter of the TIP36C transistor, to drop low. When point "D" is low, the coil is grounded through the transistor and turns on. The coil shuts off when point "A" toggles high.

## LOW POWER SOLENOID CIRCUIT

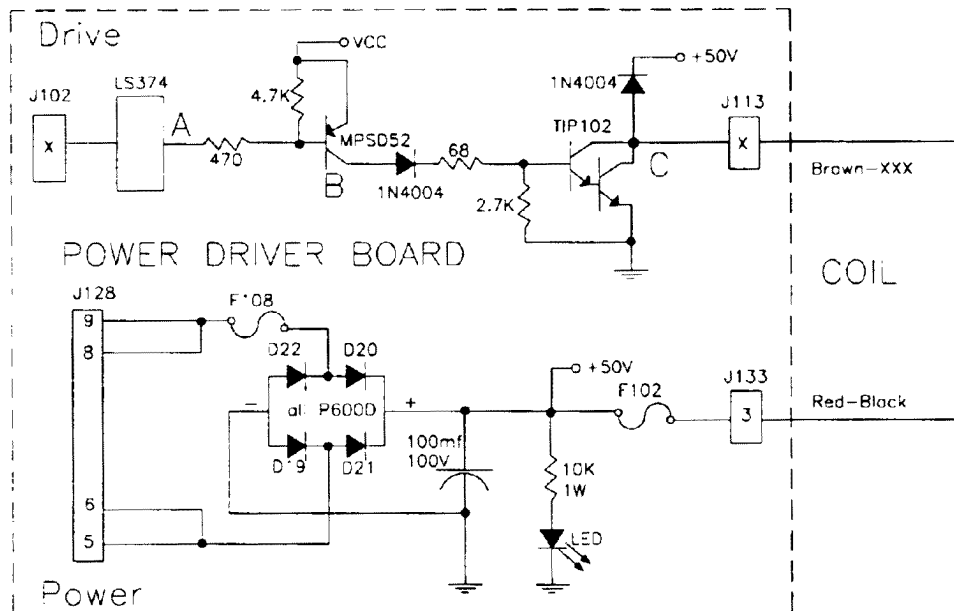

The microprocessor toggles the output of the 74LS374. When point "A" is low, point "B", the collector of the 2N5401 transistor, is high. A high at point "B" turns on the TIP102 transistor and causes point "C" to drop low. When point "C" is low the coil is grounded through the transistor and turns on. The coil shuts off when point "A" toggles high.

## SPECIAL (GENERAL PURPOSE) SOLENOID CIRCUIT

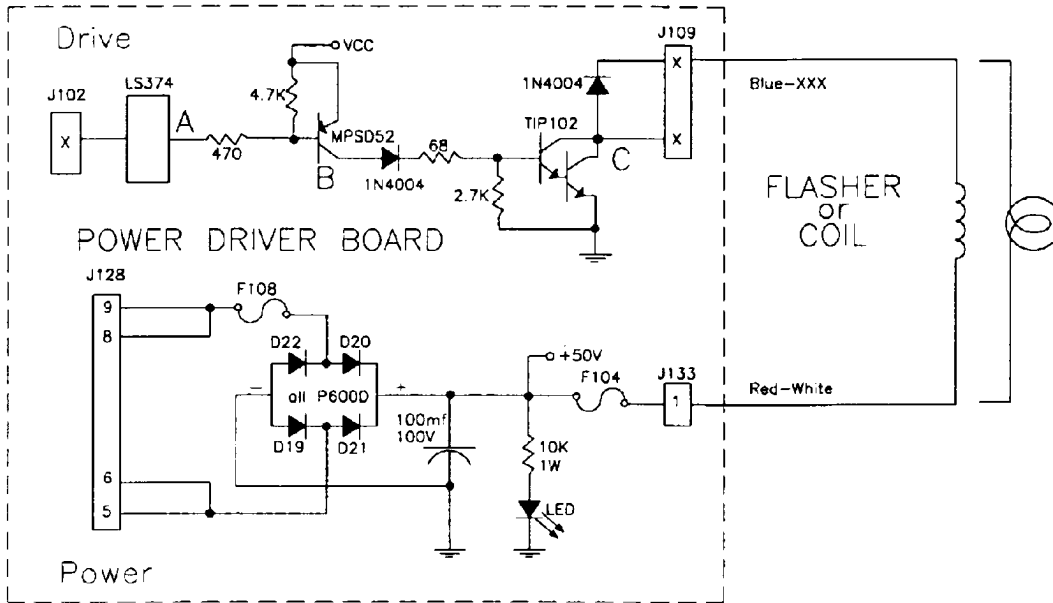

The microprocessor toggles the output of the 74LS374. When point "A" is low, point "B" the collector of the 2N5401 transistor, is high. A high at point "B" causes a low at point "C". When point "C" is low, the coil/flashlamp is grounded through the transistor and turns on. When point "A" toggles high the coil/flashlamp turns off.

\* Tieback diode is not used for flashlamp circuit.

## FLASHLAMP CIRCUIT

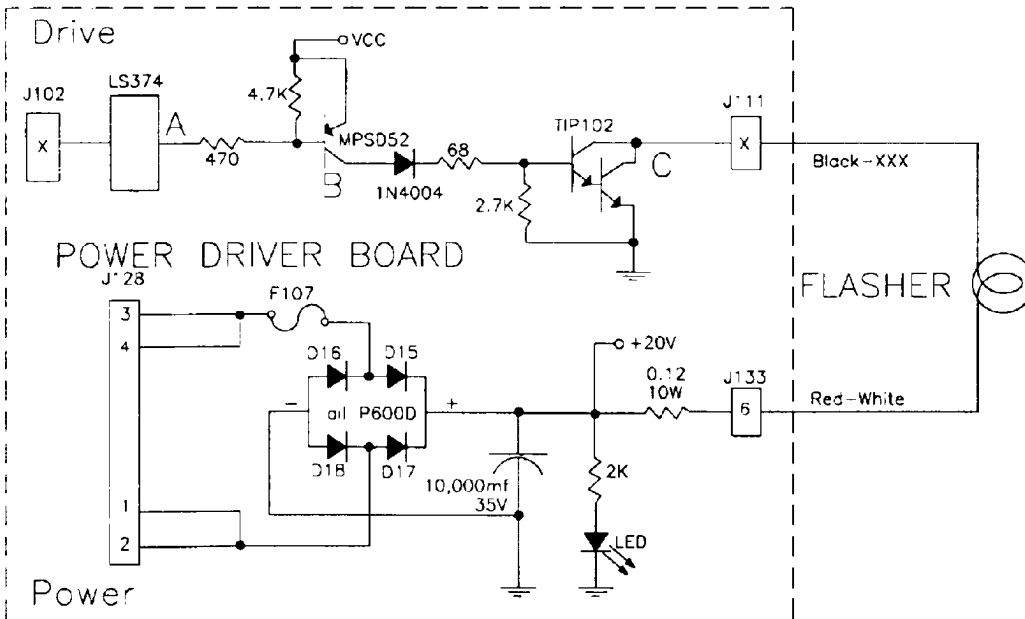

The microprocessor toggles the output of the 74LS374. When point "A" is low, point "B" the collector of the 2N5401 transistor, is high. Once point "B" is high, point "C" the collector of the TIP102 transistor is low. When point "C" is low, the flashlamp is grounded through the transistor and turns on. When point "A" toggles high, the current shuts off.

## GENERAL ILLUMINATION CIRCUIT

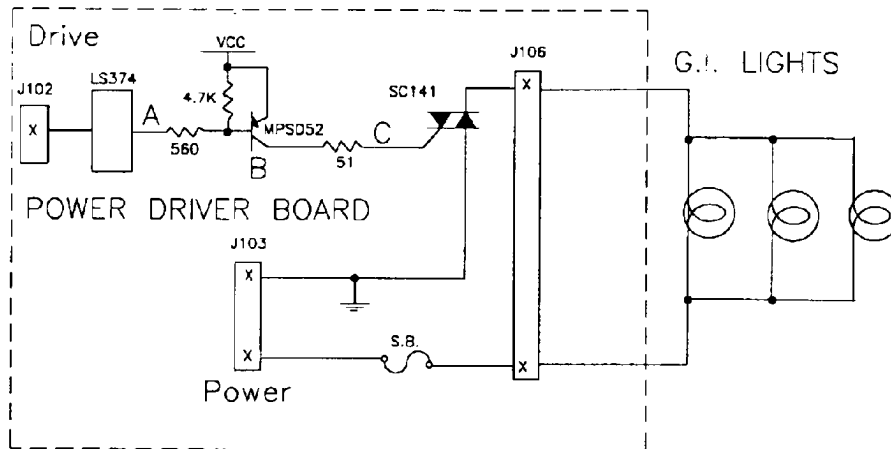

Figure #1

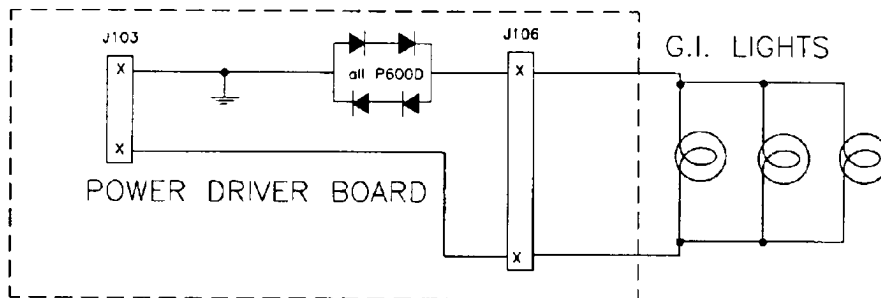
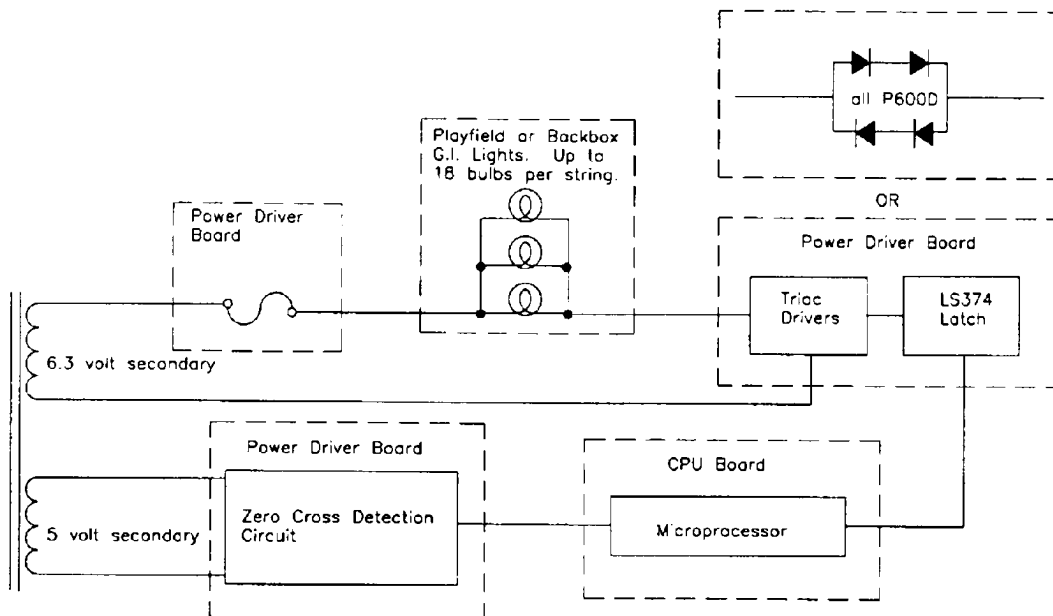

Figure #2

There are five general illumination strings; three like figure #1 and two like figure #2. When point "A" toggles low, points, "B" and "C" are high. This turns on the triac and the desired general illumination string of lights.

## BLOCK DIAGRAM OF GENERAL ILLUMINATION CIRCUIT



# FLIPPER CIRCUIT DIAGRAM

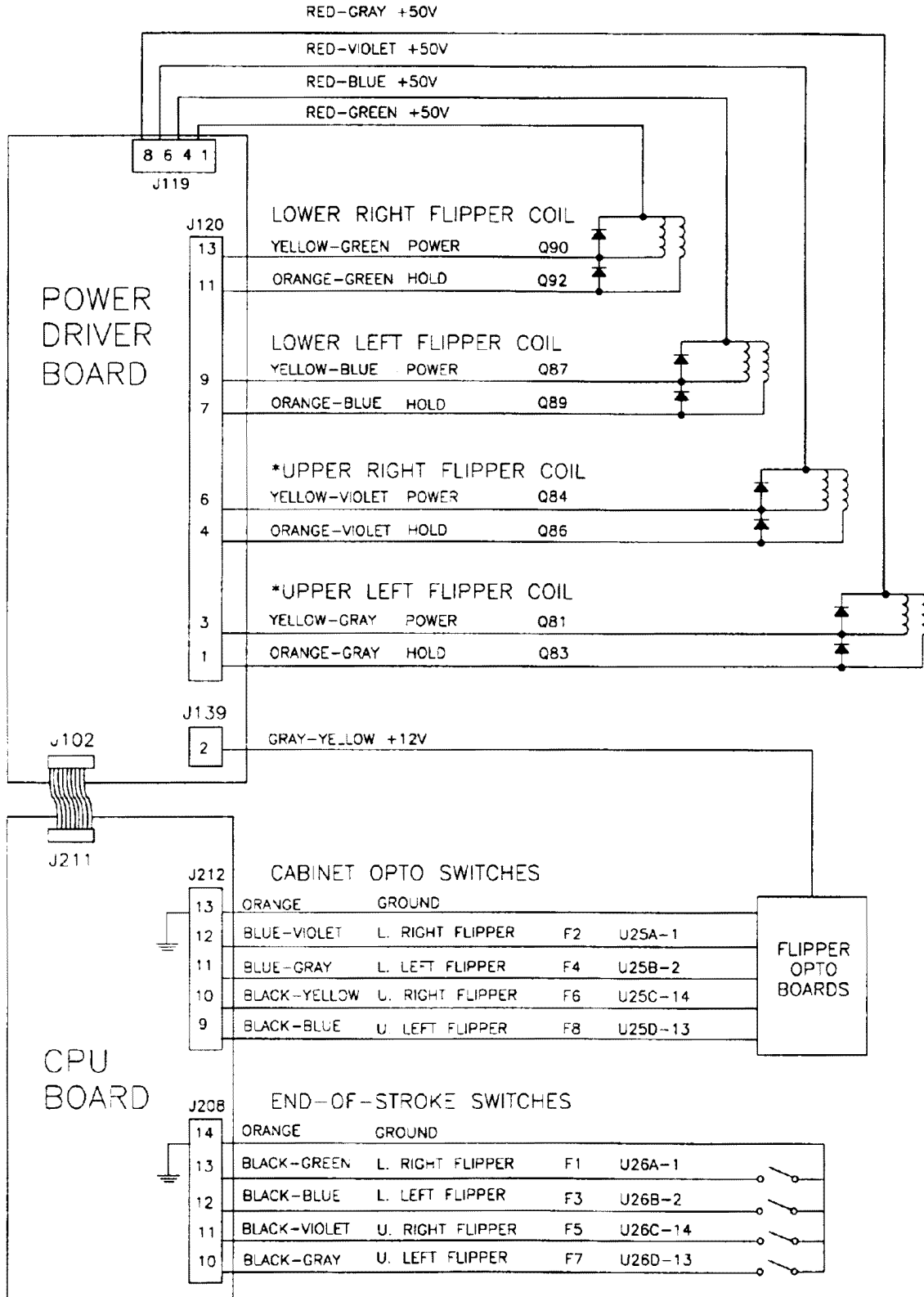

**\*NOTE: May be used as circuits other than flipper circuits.**

## FLIPPER COIL CIRCUITS

LEFT FLIPPER CIRCUIT

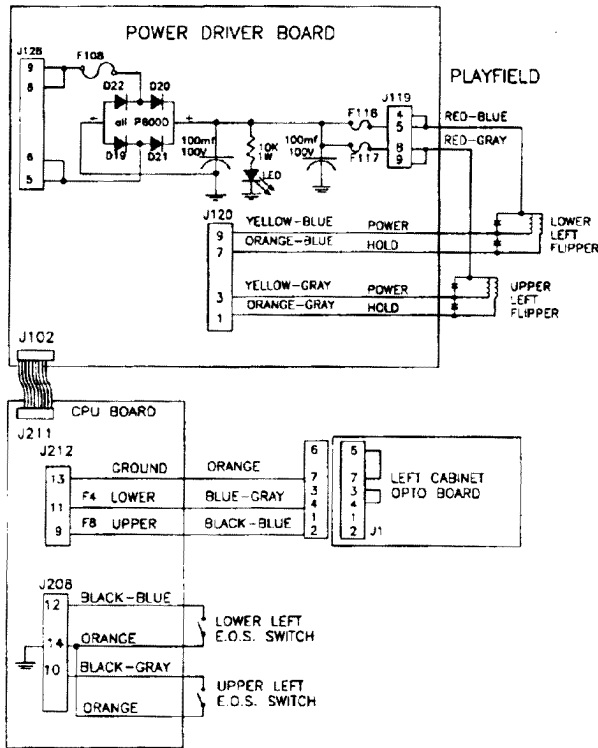

RIGHT FLIPPER CIRCUIT

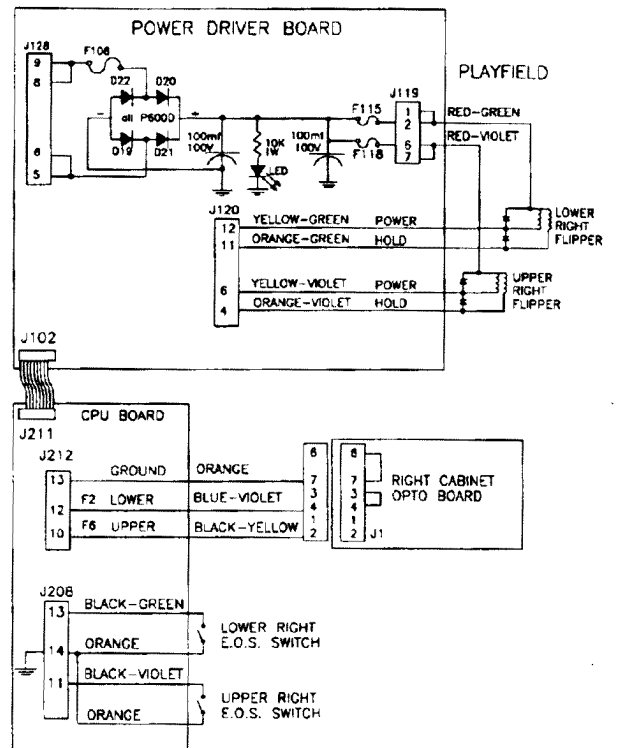

## FLIPPER END-OF-STROKE SWITCH CIRCUIT

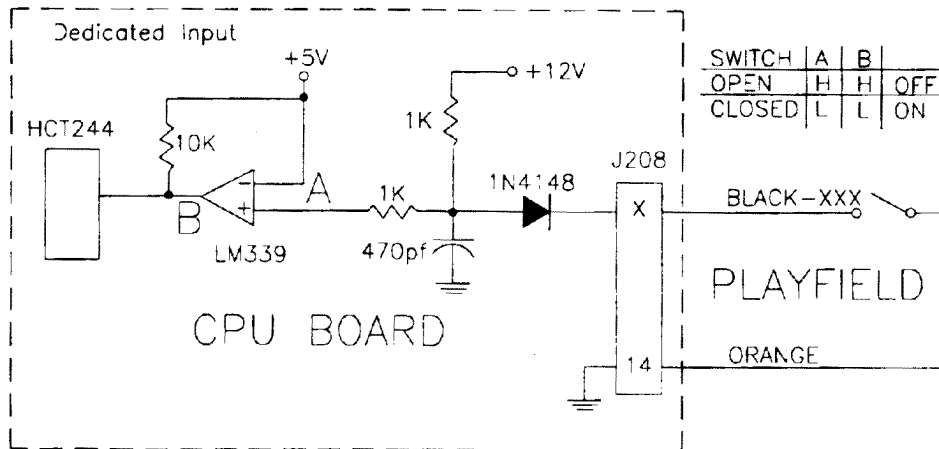

The flipper E.O.S. circuits operate similar to the dedicated switch circuit. The circuits are active low and tied to ground through the switch. When a switch closes, the row side, (dedicated input), of the circuit activates. The "+" input of the LM339 drops below +5V therefore its output is low. Since the row (dedicated input), circuit is tied directly to ground through the switch, the switch is considered closed by the microprocessor. When the switch opens, the "+" input to the LM339 is above +5V, its output is high and the row (dedicated input) is inactive.

## FLIPPER CABINET SWITCH CIRCUITS

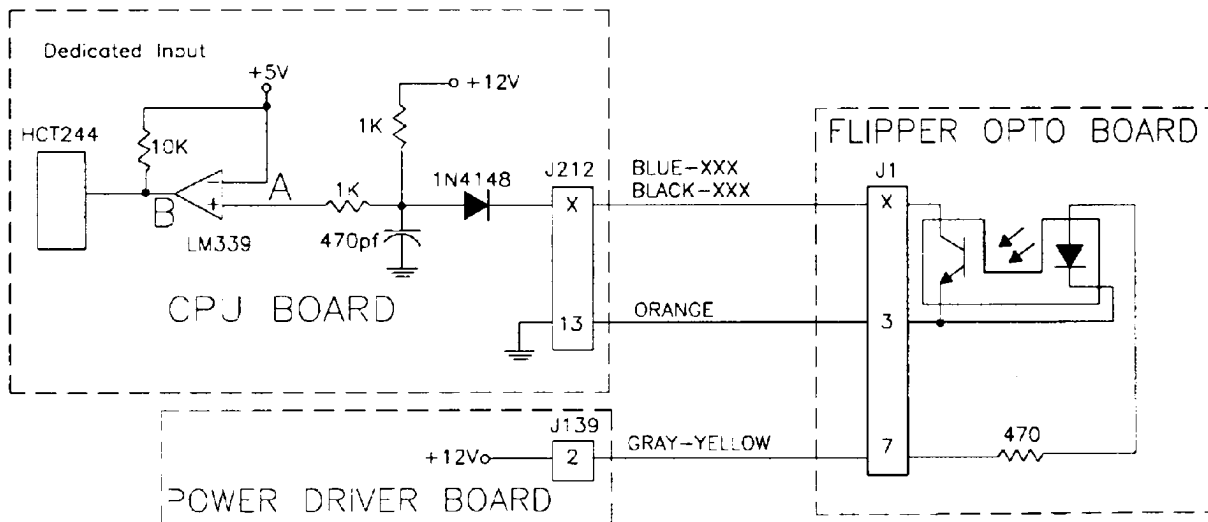
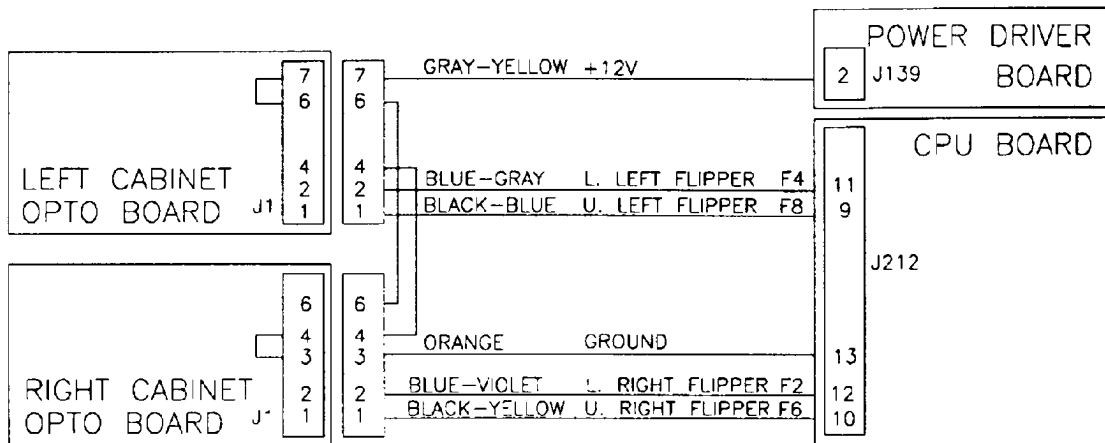

The flipper switch circuits operate similar to the dedicated switch circuit. The circuits are active low and tied to ground through the switch circuit.

When a switch closes, the row side (dedicated input) of the circuit activates. The "+" input to the LM339 drops below +5V, therefore, its output is low. Since the row, (dedicated input) circuit is tied directly to ground through the switch, the switch is considered closed by the microprocessor. When the switch opens, the "+" input to the LM339 is above +5V, its output is high and the row, (dedicated Input) is inactive.

**LED P.C.B. Assembly (transmitter)  
A-16908**

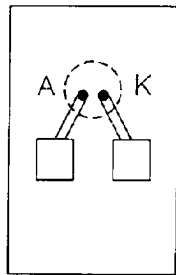
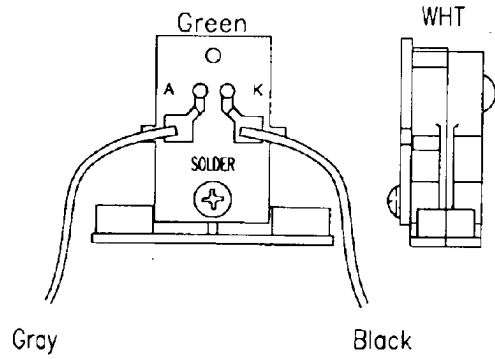

solder side

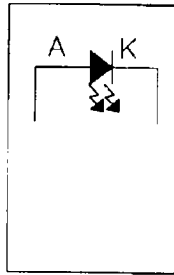

schematic

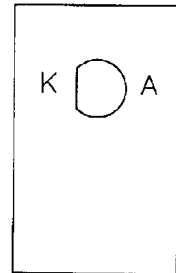

component side

**Photo Transistor P.C.B. Assembly (receiver)  
A-16909**

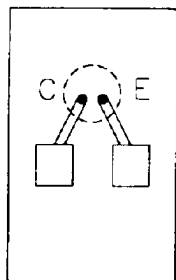
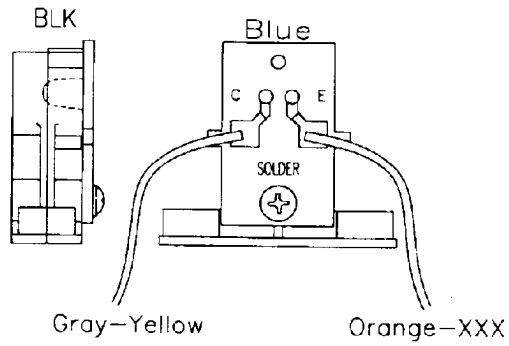

solder side

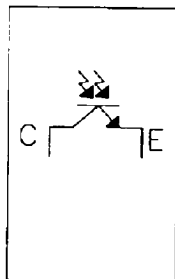

schematic

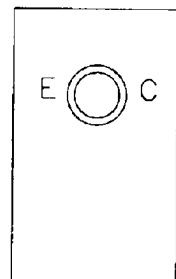

component side

## Flipper Opto P.C.B. Assembly A-17316

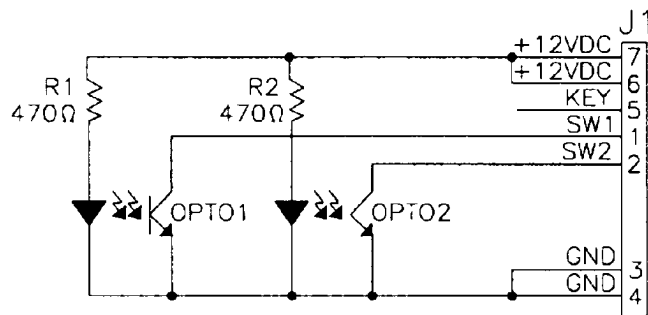
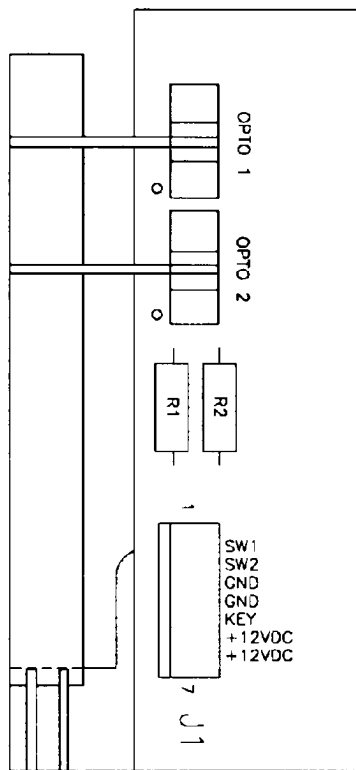

### Left Side Flipper Cabinet Opto Switch Board

- J1-1 Black-Blue from J212-9
- J1-2 Blue-Gray from CPU Bd. J212-11
- J1-3 Not Used
- J1-4 Orange to/from Right Flipper Opto Bd. J1-3
- J1-5 Key
- J1-6 Gray-Yellow to/from Right Flipper Opto Bd. J1-6
- J1-7 Gray-Yellow from Power Driver Bd. J139-2

### Right Side Flipper Cabinet Opto Switch Board

- J1-1 Black-Yellow from CPU Bd. J212-10
- J1-2 Blue-Violet from CPU Bd. J212-12
- J1-3 Orange to/from Left Flipper Opto Bd. J1-4
- J1-4 Orange from CPU Bd. J212-13
- J1-5 Key
- J1-6 Gray-Yellow to/from Left Flipper Opto J1-6
- J1-7 Not Used



**TROUGH IRED LED P.C.B. ASSEMBLY  
A-18617-1**

- J1-1 Gray-Violet, from 16 Opto P.C.B. J1-2
- J1-2 Gray-Blue, from 16 Opto P.C.B. J1-3
- J1-3 Gray-Green, from 16 Opto P.C.B. J1-4
- J1-4 Gray-Black, from 10 Opto P.C.B. J1-5
- J1-5 Gray-Orange, from 10 Opto P.C.B. J1-6
- J1-6 Gray-Red, from 10 Opto P.C.B. J1-7
- J1-7 Gray-Brown, from 10 Opto P.C.B. J1-8
- J1-8 Key
- J1-9 Black, from 16 Opto P.C.B. J1-10

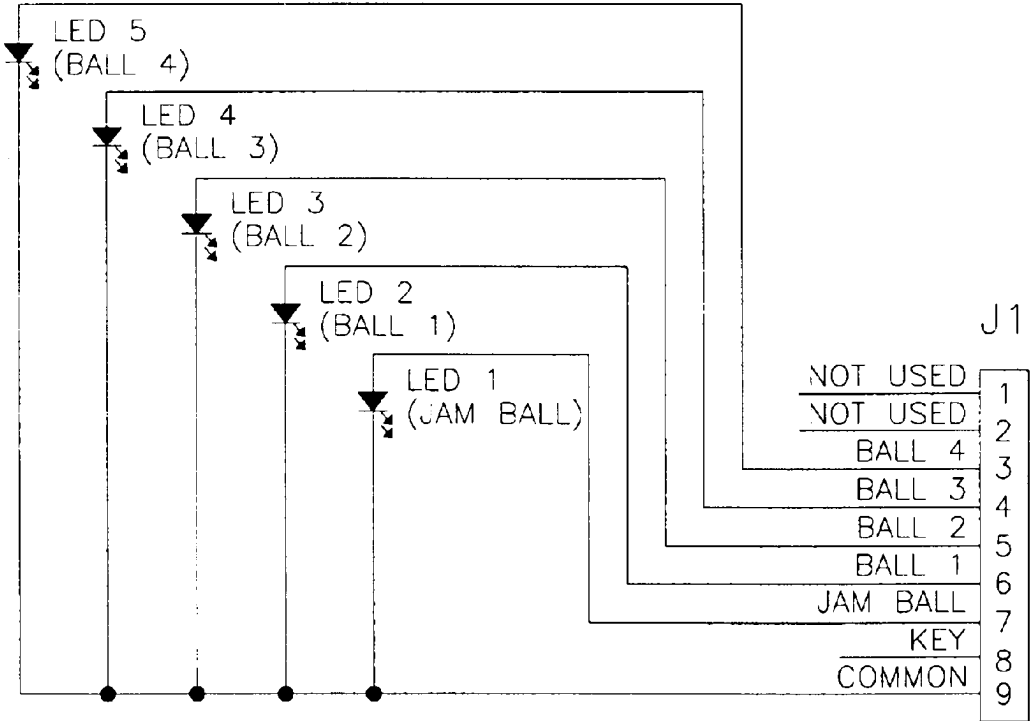
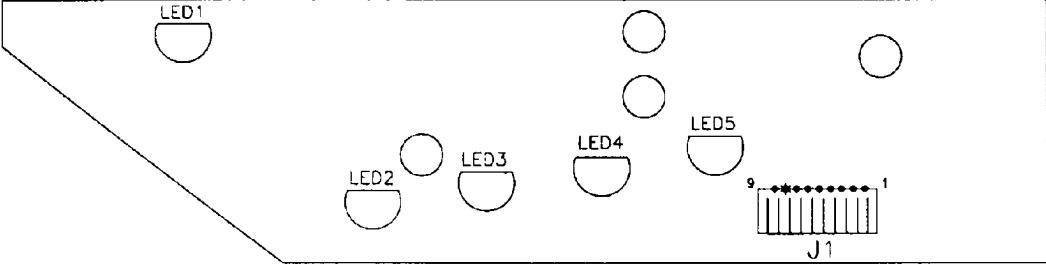

Trough 7 IRED Circuit

# TROUGH IRED TRANSISTOR P.C.B. ASSEMBLY A-18618-1

- J1-1 Gray-Yellow, from 16 Opto P.C.B. J2-1
- J1-2 Key
- J1-3 Orange-Brown, from 16 Opto P.C.B. J2-10
- J1-4 Orange-Red, from 16 Opto P.C.B. J2-9
- J1-5 Orange-Black, from 16 Opto P.C.B. J2-8
- J1-6 Orange-Yellow, from 16 Opto P.C.B. J2-7
- J1-7 Orange-Green, from 16 Opto P.C.B. J2-6
- J1-8 Orange-Blue, from 16 Opto P.C.B. J2-4
- J1-9 Orange-Violet, from 16 Opto P.C.B. J2-3

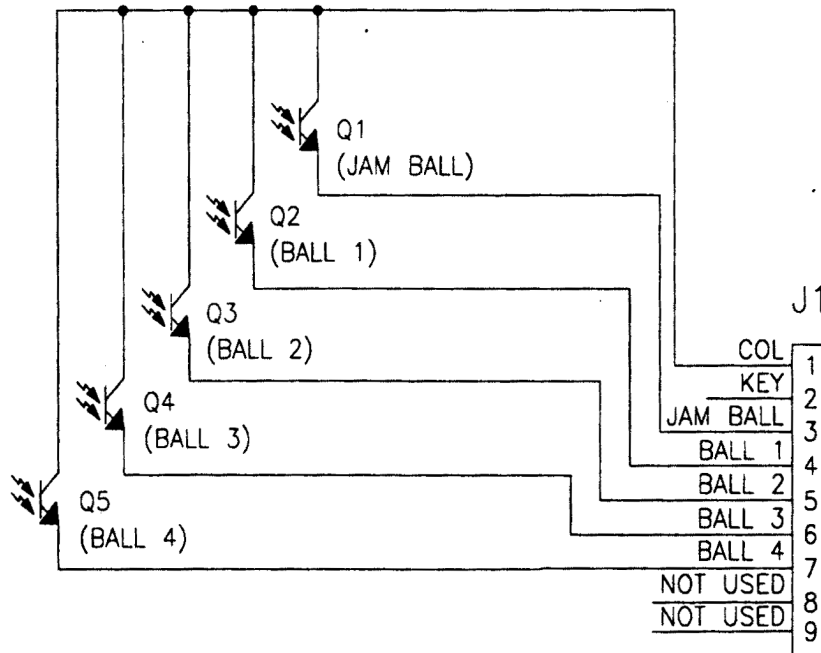
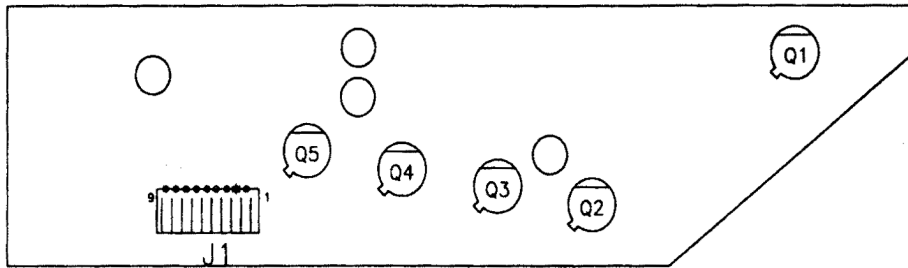

Trough 7 IR TSTR Circuit

# STEPPER MOTOR PCB ASSEMBLY D-12046

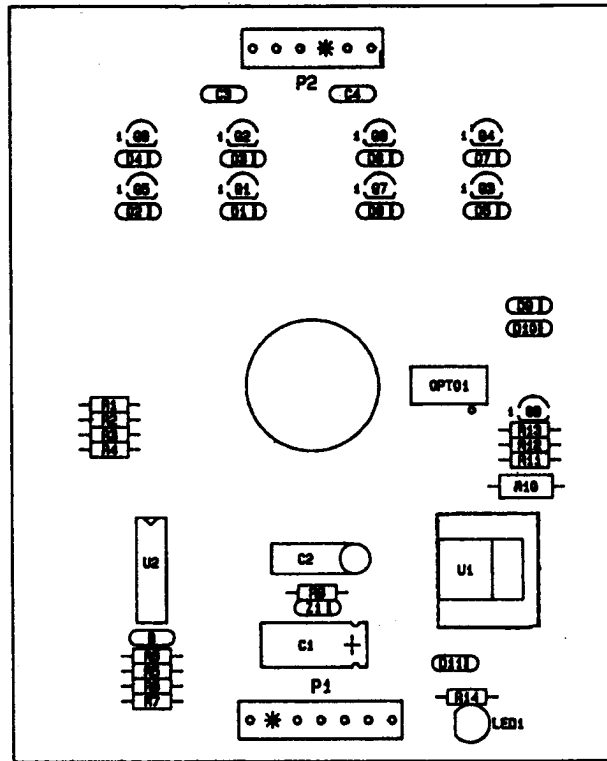

**16 OPTO P.C.B.  
A-16998.2**

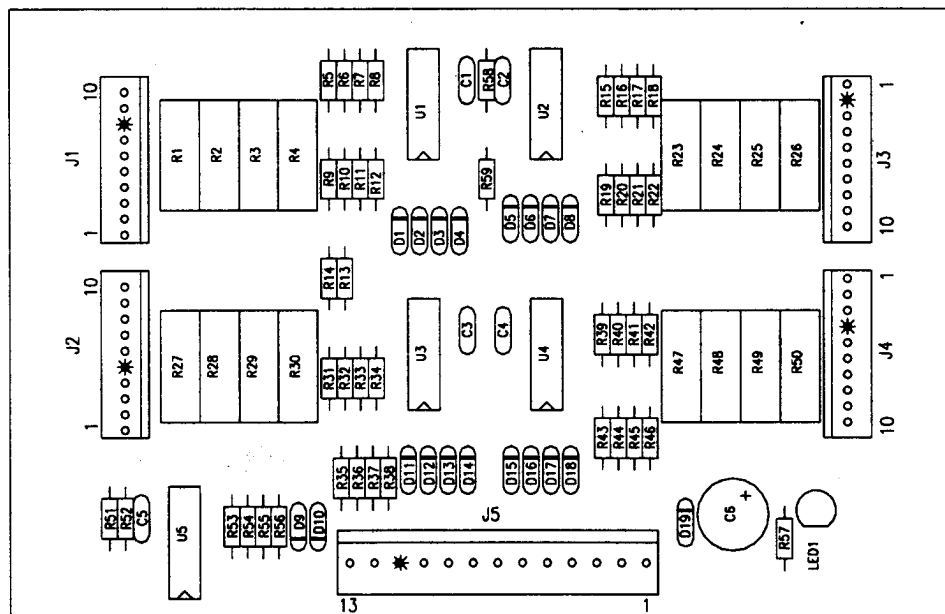

# 16 OPTO P.C.B. SCHEMATIC A-16998.2

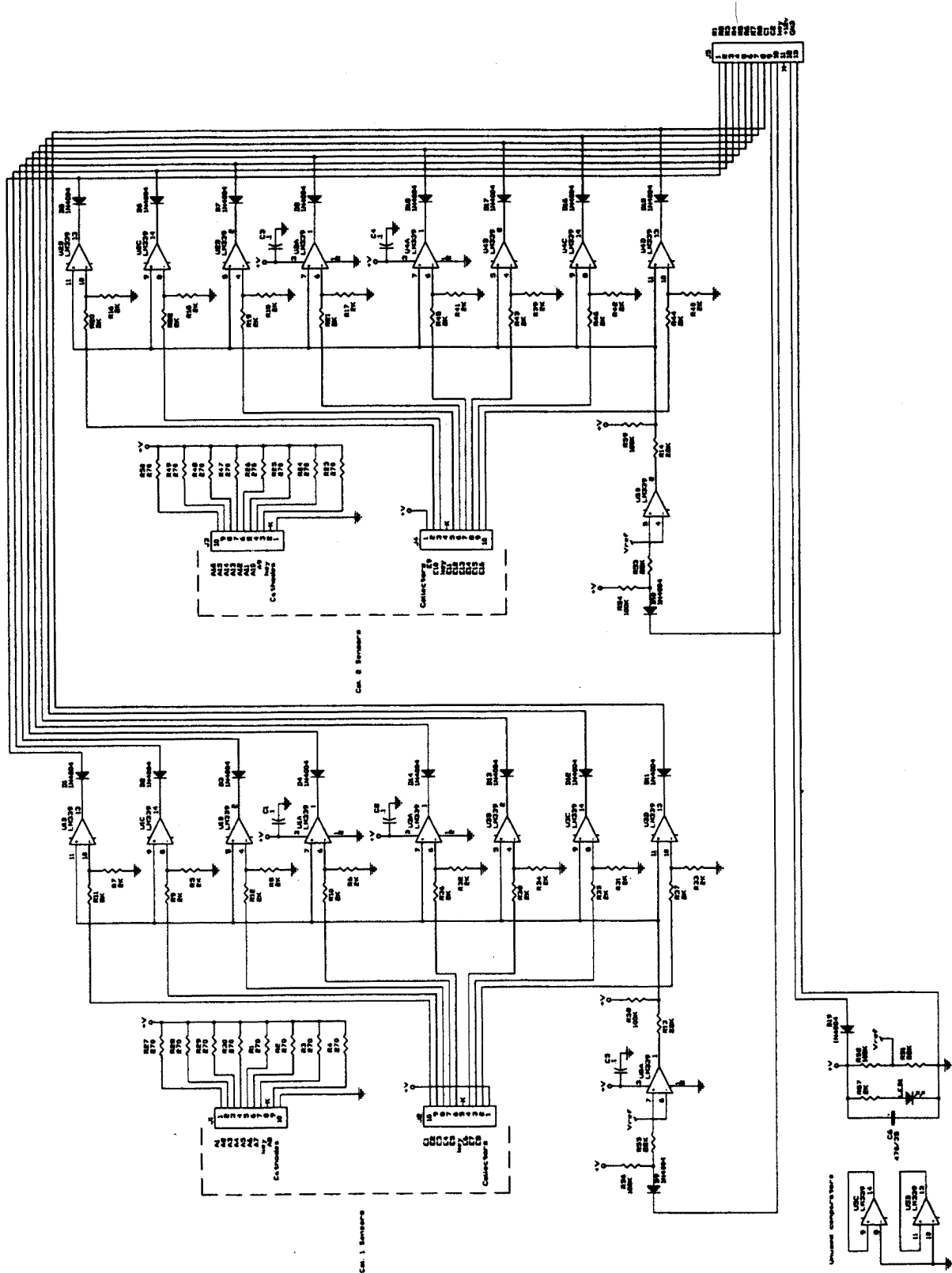

# EDDY SENSOR P.C.B. A-18543.1-2

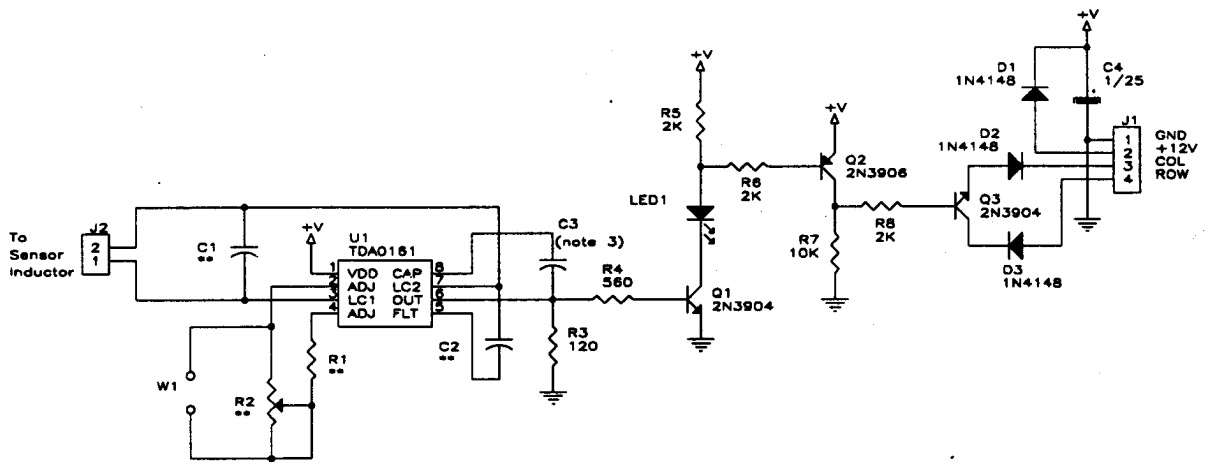
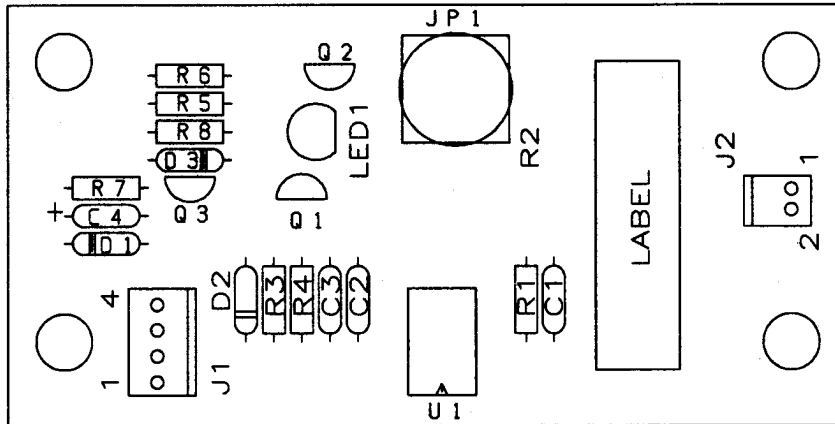

SCHEMATIC

# POWER DRIVER BOARD ASSEMBLY A-20028

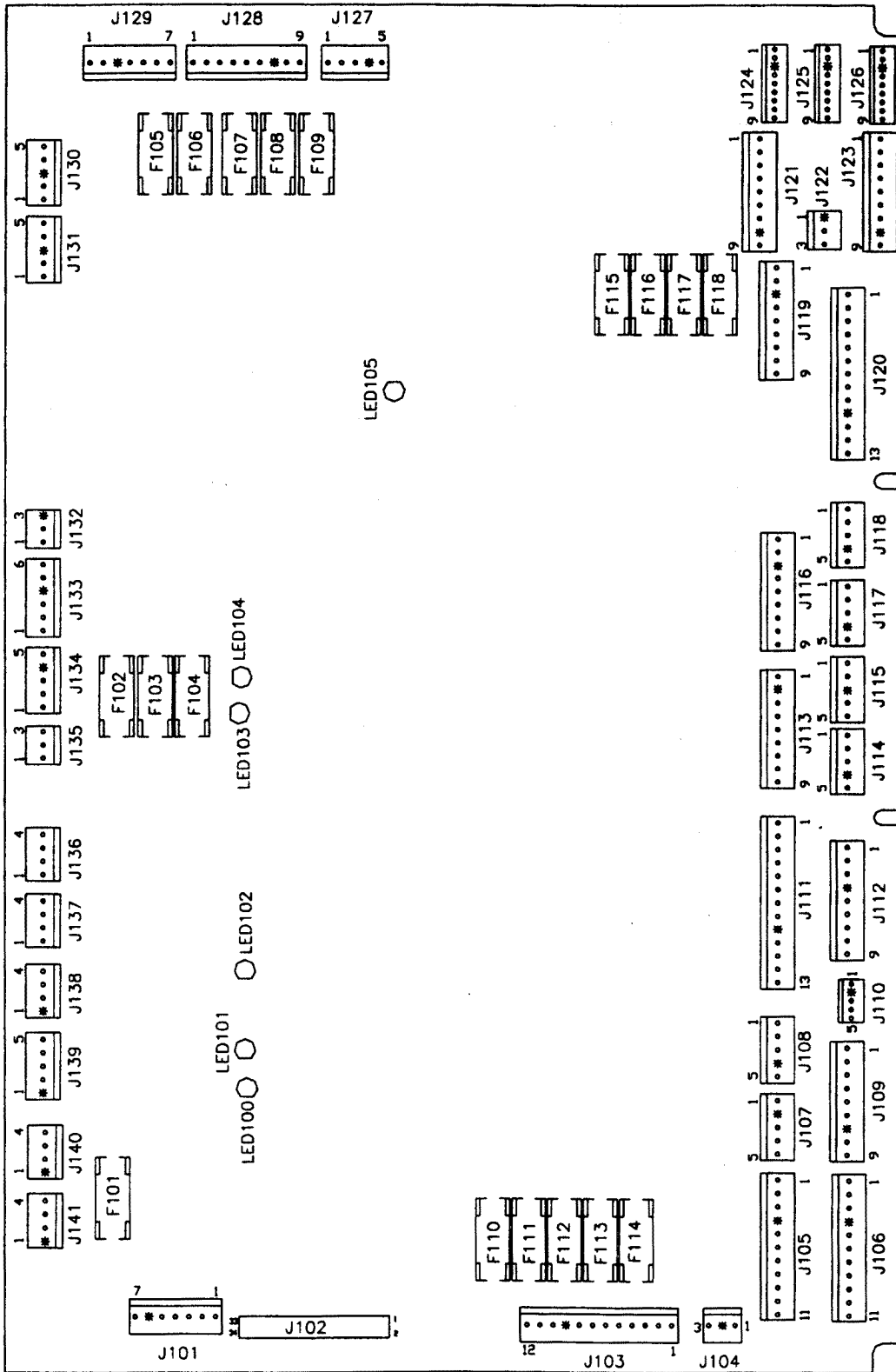

J101-1 Gray-Green, +12V to J210-7, J606-7  
 J101-2 Gray-Green, +12V to J210-6, J606-6  
 J101-3 Gray, +5V to J210-5, J606-5  
 J101-4 Gray, +5V to J210-4, J606-4  
 J101-5 Black, Ground to J210-3, J606-3  
 J101-6 Key  
 J101-7 Black, Ground to J210-1, J606-1  
  
 J102 34-Pin Ribbon Cable, Data to/from CPU J211  
  
 J104-1 White-Violet, 6.8VAC G.I. to Coin Door Bd. J2-3  
 J104-2 Key  
 J104-3 Violet, Return, G.I. to Coin Door Bd. J2-5  
  
 J105-1 Brown, Return, G.I. to Coin Door Board J2-5  
 J105-2 Orange, Return, G.I. to Playfield  
 J105-3 Yellow, Return, G.I. to Playfield  
 J105-4 Key  
 J105-5 Not Used  
 J105-6 Not Used  
 J105-7 White-Brown, 6.8VAC, G.I. to Coin Door Bd. J2-3  
 J105-8 White-Orange, 6.8VAC, G.I. to Playfield  
 J105-9 White-Yellow, 6.8VAC, G.I. to Playfield  
 J105-10 Not Used  
 J105-11 Not Used  
  
 J106-1 Not Used  
 J106-2 Not Used  
 J106-3 Not Used  
 J106-4 Key  
 J106-5 Green, Return G.I. to Insert Panel  
 J106-6 Violet, Return G.I. to Insert Panel  
 J106-7 Not Used  
 J106-8 Not Used  
 J106-9 Not Used  
 J106-10 White-Green, 6.8VAC, G.I. to Insert Panel  
 J106-11 White-Violet, 6.8VAC, G.I. to Insert Panel  
  
 J107-1 Not Used  
 J107-2 Key  
 J107-3 Blue-Red to Insert Flasher  
 J107-4 Not Used  
 J107-5 Not Used  
  
 J108 Not Used  
  
 J109-1 Blue-Brown, Solenoid 25 to Playfield Coil  
 J109-2 Blue-Red, Solenoid 26 to Playfield Flasher  
 J109-3 Blue-Orange, Solenoid 27 to Playfield Flasher  
 J109-4 Blue-Yellow, Solenoid 28 to Playfield Flasher  
 J109-5 Red-Brown Tieback Diode  
 J109-6 Not Used  
 J109-7 Key  
 J109-8 Not Used  
 J109-9 Not Used

J110-1 Brown-White to Solenoid 37 to Playfield  
 J110-2 Key  
 J110-3 Orange-White to Solenoid 38 to Playfield  
 J110-4 Yellow-White to Solenoid 39 to Insert  
 J110-5 Green-White to Solenoid 40 to Insert  
  
 J111-1 Black-Brown, Solenoid 17 to Playfield Flasher  
 J111-2 Black-Red, Solenoid 18 to Playfield Flasher  
 J111-3 Black-Orange, Solenoid 19 to Playfield Flasher  
 J111-4 Black-Yellow, Solenoid 20 to Playfield Coil  
 J111-5 Not Used  
 J111-6 Blue-Black, Solenoid 22 to Playfield Flasher  
 J111-7 Blue-Violet, Solenoid 23 to Playfield Flasher  
 J111-8 Blue-Gray, Solenoid 24 to Playfield Flasher  
 J111-9 Key  
 J111-10 Not Used  
 J111-11 Not Used  
 J111-12 Not Used  
 J111-13 Not Used  
  
 J112-1 Black-Brown to Insert Flasher  
 J112-2 Black-Red to Insert Flasher  
 J112-3 Black-Orange to Insert Flasher  
 J112-4 Key  
 J112-5 Blue-Green to Insert Flasher  
 J112-6 Not Used  
 J112-7 Not Used  
 J112-8 Not Used  
 J112-9 Not Used  
  
 J113-1 Brown-Black, Solenoid 9 Drive to Playfield Coil  
 J113-2 Key  
 J113-3 Brown-Red, Solenoid 10 to Playfield Coil  
 J113-4 Brown-Orange, Solenoid 11 to Playfield Coil  
 J113-5 Brown-Yellow, Solenoid 12 to Playfield Coil  
 J113-6 Brown-Green, Solenoid 13 to Playfield Coil  
 J113-7 Brown-Blue, Solenoid 14 to Playfield Coil  
 J113-8 Brown-Violet, Solenoid 15 to Playfield Coil  
 J113-9 Brown-Gray, Solenoid 16 to Playfield Coil  
  
 J114 Not Used  
  
 J115 Not Used  
  
 J116-1 Violet-Brown, Solenoid 1 to Playfield Coil  
 J116-2 Violet-Red, Solenoid 2 to Playfield Coil  
 J116-3 Key  
 J116-4 Violet-Orange, Solenoid 3 to Playfield Coil  
 J116-5 Violet-Yellow, Solenoid 4 to Playfield Coil  
 J116-6 Violet-Green, Solenoid 5 to Playfield Coil  
 J116-7 Violet-Blue, Solenoid 6 to Playfield Coil  
 J116-8 Violet-Black, Solenoid 7 to Backbox Coil  
 J116-9 Violet-Gray, Solenoid 8 to Playfield Coil  
  
 J117 Not Used  
  
 J118 Not Used

J119-1 Red-Green, +50V to Lower Right Flipper Coil  
J119-2 Red-Green, Loop End from J119-1  
J119-3 Key  
J119-4 Red-Blue, +50V to Lower Left Flipper  
J119-5 Red-Blue, Loop End from J119-4  
J119-6 Red-Violet, +50V to Playfield Coil  
J119-7 Red-Violet, Loop End from J119-6  
J119-8 Red-Gray, +50V to Playfield Coil  
J119-9 Red-Gray, Loop End from J119-8

J120-1 Orange-Gray, Holding, Playfield Coil  
J120-2 Not Used  
J120-3 Yellow-Gray, Power, Playfield Coil  
J120-4 Orange-Violet, Holding, Playfield Coil  
J120-5 Not Used  
J120-6 Yellow-Violet, Playfield Coil  
J120-7 Orange-Blue, Holding, Lower Left Flipper Coil  
J120-8 Not Used  
J120-9 Yellow-Blue, Power, Lower Left Flipper Coil  
J120-10 Key  
J120-11 Orange-Green, Holding, Lwr Right Flipper Coil  
J120-12 Not Used  
J120-13 Yellow-Green, Power, Lower Right Flipper Coil

J121-1 Yellow-Brown, Lamp Col. 1 to Playfield  
J121-2 Yellow-Red, Lamp Col. 2 to Playfield  
J121-3 Yellow-Orange, Lamp Col. 3 to Playfield  
J121-4 Yellow-Black, Lamp Col. 4 to Playfield  
J121-5 Yellow-Green, Lamp Col. 5 to Playfield  
J121-6 Yellow-Blue, Lamp Col. 6 to Playfield  
J121-7 Not Used  
J121-8 Key  
J121-9 Yellow-Gray, Lamp Col. 8 to Playfield

J122-1 Key  
J122-2 Not Used  
J122-3 Yellow-Gray, Lamp Col 8 to Coin Door Bd. J3-9

J123-1 Not Used  
J123-2 Not Used  
J123-3 Not Used  
J123-4 Not Used  
J123-5 Not Used  
J123-6 Yellow-Blue to Insert Lamps  
J123-7 Yellow-Violet to Insert Lamps  
J123-8 Key  
J123-9 Yellow-Gray to Insert Lamps

J124 -1 Red-Brown, Lamp Row 1 to Playfield  
J124 -2 Red-Black, Lamp Row 2 to Playfield  
J124 -3 Key  
J124 -4 Red-Orange, Lamp Row 3 to Playfield  
J124 -5 Red-Yellow, Lamp Row 4 to Playfield  
J124 -6 Red-Green, Lamp Row 5 to Playfield  
J124 -7 Red-Blue, Lamp Row 6 to Playfield  
J124 -8 Red-Violet, Lamp Row 7 to Playfield  
J124 -9 Red-Gray, Lamp Row 8 to Playfield

J125-1 Not Used  
J125-2 Not Used  
J125-3 Key  
J125-4 Not Used  
J125-5 Not Used  
J125-6 Not Used  
J125-7 Red-Blue, Lamp Row 6 to Coin Door Bd. J3-10  
J125-8 Red-Violet, Lamp Row 7 to Coin Door Bd. J3-11  
J125-9 Red-Gray, Lamp Row 8 to Coin Door Bd. J3-12

J126-1 Red-Brown, Lamp Row 1 to Insert  
J126-2 Red-Black, Lamp Row 2 to Insert  
J126-3 Key  
J126-4 Red-Orange, Lamp Row 3 to Insert  
J126-5 Red-Yellow, Lamp Row 4 to Insert  
J126-6 Red-Green, Lamp Row 5 to Insert  
J126-7 Red-Blue, Lamp Row 6 to Insert  
J126-8 Red-Violet, Lamp Row 7 to Insert  
J126-9 Red-Gray, Lamp Row 8 to Insert

J127-1 White-Green, 9.8VAC from Xformer Secondary  
J127-2 White-Green, 9.8VAC Loop End from J127-1  
J127-3 White-Green, 9.8VAC from Xformer Secondary  
J127-4 Key  
J127-5 White-Green, 9.8VAC Loop End from J127-3

J128-1 White-Red, 16VAC Loop End from J128-2  
J128-2 White-Red, 16VAC from Xformer Secondary  
J128-3 White-Red, 16VAC Loop End from J128-4  
J128-4 White-Red, 16VAC from Xformer Secondary  
J128-5 Black-Yellow, 16VAC Loop End from J128-6  
J128-6 Black-Yellow, 16VAC from Xformer Secondary  
J128-7 Key  
J128-8 Black-Yellow, 16VAC Loop End from J128-9  
J128-9 Black-Yellow, 16VAC from Xformer Secondary

J129-1 Red, 9VAC from Xformer Secondary  
J129-2 Red, 9VAC from Xformer Secondary  
J129-3 Key  
J129-4 Blue-White, 13VAC from Xformer Secondary  
J129-5 Blue-White, 13VAC Loop End from J129-4  
J129-6 Blue-White, 13VAC from Xformer Secondary  
J129-7 Blue-White, 13VAC Loop End from J129-6

J130 Not Used

J131 Not Used

J132 Not Used

J133-1 Not Used  
J133-2 Red-Brown, +50V to Playfield Coils  
J133-3 Red-Black, +50V to Playfield Coils  
J133-4 Key  
J133-5 Not Used  
J133-6 Red-White, +20V to Playfield Flashlamps



J134-1 Not Used  
J134-2 Not Used  
J134-3 Not Used  
J134-4 Key  
J134-5 Red-White, +20VDC to Insert Flashlamps

J135 Not Used

J136 Not Used

J137 Not Used

J138 Not Used

J139-1 Key  
J139-2 Gray-Yellow +12V to Coin Door Bd. J2-2  
J139-3 Black Ground to Coin Door Bd. J2-1  
J139-4 Not Used  
J139-5 Black-White to Coin Door Bd. J2-7

J140-1 Key  
J140-2 Gray-Yellow, +12V to Playfield Switches  
J140-3 Black, Ground to Playfield Switches  
J140-4 Not Used

J141-1 Key  
J141-2 Gray-Yellow, +12V to Playfield Solenoids  
J141-3 Black, Ground to Playfield Solenoids  
J141-4 Not Used

# SECURITY CPU BOARD ASSEMBLY A-21377-50048

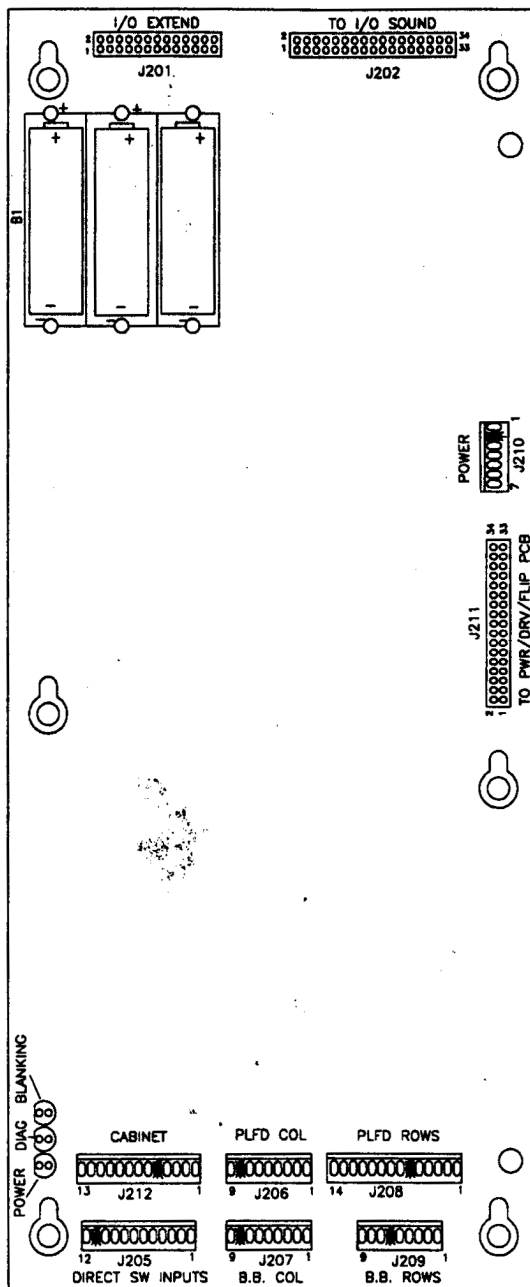

J201 26-Pin Ribbon Cable, Data to/from J602

J202 34-Pin Ribbon Cable, Data to/from J601

J203 Not Used

J204 Not Used

J205-1 Orange-Brown, Ded. Sw. Row 1, to Coin Door Bd. J1-8

J205-2 Orange-Red, Ded. Sw. Row 2, to Coin Door Bd. J1-7

J205-3 Orange-Black, Ded. Sw. Row 3, to Coin Door Bd. J1-6

J205-4 Orange-Yellow, Ded. Sw. Row 4, to Coin Door Bd. J1-5

J205-5 Not Used

J205-6 Orange-Green, Ded. Sw. Row 5, to Coin Door Bd. J1-4

J205-7 Orange-Blue, Ded. Sw. Row 6, to Coin Door Bd. J1-3

J205-8 Orange-Violet, Ded. Sw. Row 7, to Coin Door Bd. J1-2

J205-9 Orange-Gray, Ded. Sw. Row 8, to Coin Door Bd. J1-1

J205-10 Black, Ground, to Coin Door Bd. J1-10

J205-11 Key

J205-12 Orange-White, Sw. Enable, to Coin Door Bd. J1-11

J206-1 Green-Brown, Sw. Col. 1, to Playfield Sw.  
J206-2 Green-Red, Sw. Col. 2, to Playfield Sw.  
J206-3 Green-Orange, Sw. Col. 3, to Playfield Sw.  
J206-4 Green-Yellow, Sw. Col. 4, to Playfield Sw.  
J206-5 Green-Black, Sw. Col. 5, to Playfield Sw.  
J206-6 Green-Blue, Sw. Col. 6, to Playfield Sw.  
J206-7 Green-Violet, Sw. Col. 7, to Playfield Sw.  
J206-8 Key  
J206-9 Not Used

J207-1 Green-Brown, Sw. Col. 1, to Backbox Sw.  
J207-2 Not Used  
J207-3 Not Used  
J207-4 Not Used  
J207-5 Not Used  
J207-6 Not Used  
J207-7 Not Used  
J207-8 Key  
J207-9 Not Used

J208-1 White-Brown, Sw. Row 1, to Playfield Sw.  
J208-2 White-Red, Sw. Row 2, to Playfield Sw.  
J208-3 White-Orange, Sw. Row 3, to Playfield Sw.  
J208-4 White-Yellow, Sw. Row 4, to Playfield Sw.  
J208-5 White-Green, Sw. Row 5, to Playfield Sw.  
J208-6 Key  
J208-7 White-Blue, Sw. Row 6, to Playfield Sw.  
J208-8 White-Violet, Sw. Row 7, to Playfield Sw.  
J208-9 White-Gray, Sw. Row 8, to Playfield Sw.  
J208-10 Not Used  
J208-11 Not Used  
J208-12 Black-Blue, F3, to Lwr Left E.O.S. Sw.  
J208-13 Black-Green, F1, to Lwr Right E.O.S. Sw.  
J208-14 Orange, Ground to E.O.S. Sw.

J209-1 White-Brown, Sw. Row 1, to Backbox Sw.  
J209-2 Not Used  
J209-3 Not Used  
J209-4 Not Used  
J209-5 Not Used  
J209-6 Key  
J209-7 Not Used  
J209-8 Not Used  
J209-9 Not Used

J210-1 Black, Ground, to/from J101-7, J606-1  
J210-2 Key  
J210-3 Black, Ground, to/from J101-5, J606-3  
J210-4 Gray, +5V, to/from J101-4, J606-4  
J210-5 Gray, +5V, to/from J101-3, J606-5  
J210-6 Gray-Green, +12V, to/from J101-2, J606-6  
J210-7 Gray-Green, +12V, to/from J101-1, J606-7

J211 34-Pin Ribbon Cable, Data to/from J102

J212-1 Green-Brown, Sw. Col. 1, to Coin Door Board J3-1  
J212-2 Green-Red, Sw. Col. 2, to Coin Door Board J3-2  
J212-3 Not Used  
J212-4 White-Brown, Sw. Row 1, to Coin Door Board J3-3  
J212-5 Key  
J212-6 White-Red, Sw. Row 2, to Coin Door Board J3-4  
J212-7 White-Orange, Sw. Row 3, to Coin Door Board J3-5  
J212-8 White-Yellow, Sw. Row 4, to Coin Door Board J3-6  
J212-9 Black-Blue, F8, Coin Door Board J13-2  
J212-10 Black-Yellow, F6, to Right Flipper Opto Board J1-1  
J212-11 Blue-Gray, F4, to Left Flipper Opto Board J1-2  
J212-12 Blue-Violet, F2, to Right Flipper Opto Board J1-2  
J212-13 Orange, Ground to Right Flipper Opto Board J1-4

## AUDIO VISUAL BOARD ASSEMBLY A-20516-50048

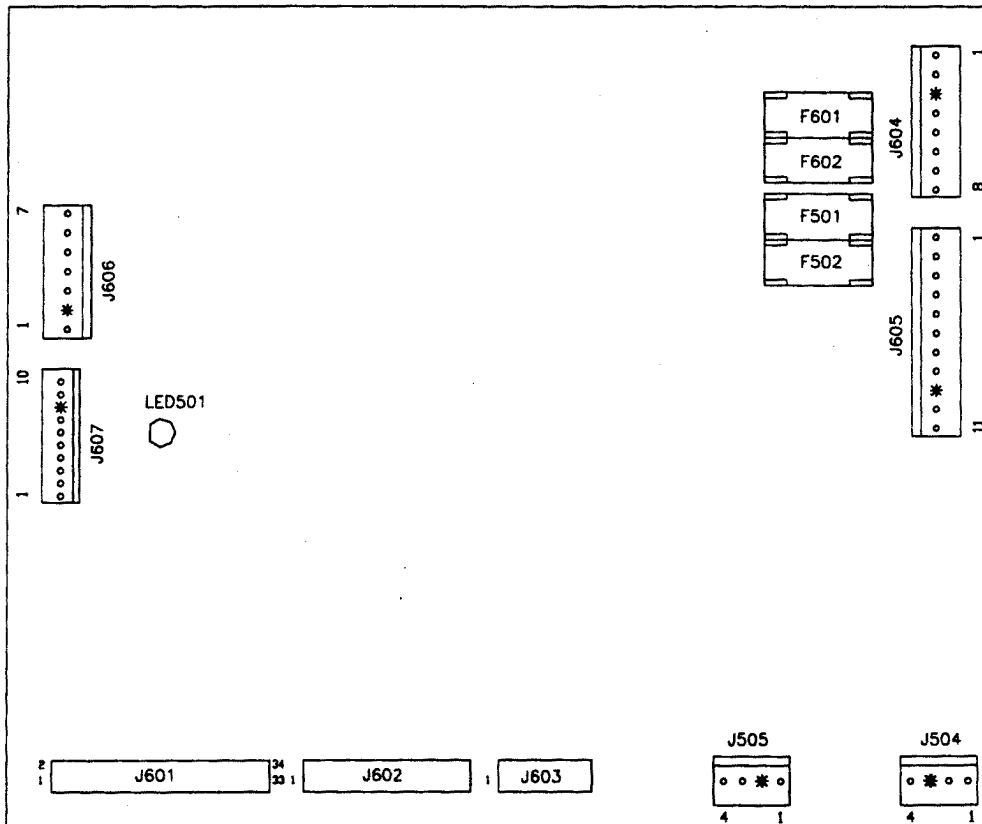

J601 34-Pin Ribbon Cable, Data to CPU J202

J602 26-Pin Ribbon Cable, Data to CPU J201

J603 14-Pin Ribbon Cable, Data to/from Dot Matrix Display Driver

J604-1 Orange, -125V to Display Driver Pin 8

J604-2 Blue, -113V to Display Driver Pin 7

J604-3 Key

J604-4 Black, Ground to Display Driver Pin 5

J604-5 Black, Ground to Display Driver Pin 4

J604-6 Gray, +5V to Display Driver Pin 3

J604-7 Gray-Yellow, +12 to Display Driver Pin 2

J604-8 Brown, +62 to Display Driver Pin 1

J605-1 White, 80VAC from Transformer Secondary

J605-2 White, 80VAC from Transformer Secondary

J605-3 Violet, 100VAC from Transformer Secondary

J605-4 Violet, 100VAC from Transformer Secondary

J605-5 Gray-White, 18VAC from Transformer Secondary

J605-6 Gray-White, Loop End from J605-5

J605-7 Gray, 18VAC from Transformer Secondary

J605-8 Gray, Loop End from J605-7

J605-9 Key

J605-10 Gray-Green, 18VAC from Transformer Secondary

J605-11 Gray-Green, 18VAC Loop End from J605-10

J606-1 Black, Ground to/from J101-7, J210-1

J606-2 Key

J606-3 Black, Ground to/from J101-5, J210-3

J606-4 Gray, +5V to/from J101-4, J210-4

J606-5 Gray, +5V to/from J101-3, J210-5

J606-6 Gray-Green, +12V to/from J101-2, J210-6

J606-7 Gray-Green, +12V to/from J101-1, J210-7

J607 Not Used

J504-1 Black-Yellow, Signal to Cabinet Speaker

J504-2 Key

J504-3 Not Used

J504-4 Black, Signal to Cabinet Speaker

J505-1 Black-Yellow, Signal to Backbox Speaker

J505-2 Key

J505-3 Not Used

J505-4 Black, Signal to Backbox Speaker

## COIN DOOR INTERFACE BOARD A-20580

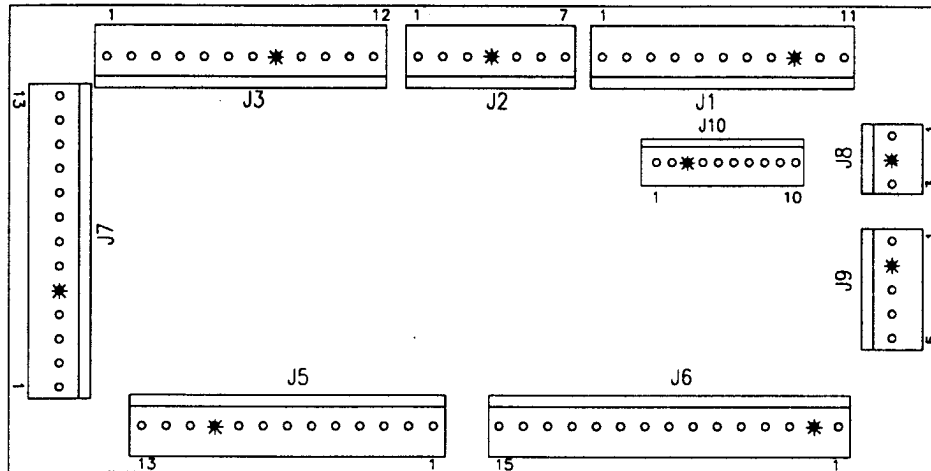

J1-1 Orange-Gray, Ded. Sw. Row 8 Form CPU J205-9  
 J1-2 Orange-Violet, Ded. Sw. Row 7 from CPU J205-8  
 J1-3 Orange-Blue, Ded. Sw. Row 6 from CPU J205-7  
 J1-4 Orange-Green, Ded. Sw. Row 5 from CPU J205-6  
 J1-5 Orange-Yellow, Ded. Sw. Row 4 from CPU J205-4  
 J1-6 Orange-Black, Ded. Sw. Row 3 from CPU J205-3  
 J1-7 Orange-Red, Ded. Sw. Row 2 from CPU J205-2  
 J1-8 Orange-Brown, Ded. Sw. Row 1 from CPU J205-1  
 J1-9 Key  
 J1-10 Black, Ground from CPU J205-10  
 J1-11 Orange-White, Sw. Enable from CPU J205-12

J2-1 Black, Ground from Power Driver Board J139-3  
 J2-2 Gray-Yellow, +12VAC from Power Driver Bd. J139-2  
 J2-3 White-Violet, GI 6.8VAC from Power Driver J104-1  
 J2-4 Key  
 J2-5 Violet, G.I. from Power Driver Bd. J104-3  
 J2-6 Not Used  
 J2-7 Black-White from J139-5

J3-1 Green-Brown, Sw. Col. 1 from CPU J212-1  
 J3-2 Green-Red, Sw. Col. 2 from CPU J212-2  
 J3-3 White-Brown, Sw. Row 1 from CPU J212-4  
 J3-4 White-Red, Sw. Row 2 from CPU J212-6  
 J3-5 White-Orange, Sw. Row 3 from CPU J212-7  
 J3-6 White-Yellow, Sw. Row 4 from CPU J212-8  
 J3-7 Not Used  
 J3-8 Key  
 J3-9 Yellow-Gray, Lamp Col. 8 from Power Driver J122-3  
 J3-10 Red-Blue, Lamp Row 6 from Power Driver J125-7  
 J3-11 Red-Violet, Lamp Row 7 from Power Driver J125-8  
 J3-12 Red-Gray, Lamp Row 8 from Power Driver J125-9

J4 Not Used

J5-1 Violet, G.I. Return to Coin Door  
 J5-2 White-Violet, G.I. 6.8VAC to Coin Door  
 J5-3 Black, Ground to Coin Door

J5-4 Not Used  
 J5-5 Orange-Red, Ded. Sw. Row 2 to Coin Door  
 J5-6 Not Used  
 J5-7 Orange-Green, Ded. Sw. Row 5 to Coin Door  
 J5-8 Orange-Blue, Ded. Sw. Row 6 to Coin Door  
 J5-9 Orange-Violet, Ded. Sw. Row 7 to Coin Door  
 J5-10 Key  
 J5-11 Orange-Gray, Ded. Sw. Row 8 to Coin Door  
 J5-12 Green-Red, Sw. Col. 2 to Coin Door Slam Tilt  
 J5-13 White-Brown, Sw. Row 1 to Coin Door Slam Tilt

J6 Not Used

J7-1 Yellow-Gray, Lamp Col. 8 to Cabinet  
 J7-2 Not Used  
 J7-3 Not Used  
 J7-4 Red-Gray, Lamp Row 8 to Cabinet  
 J7-5 Key  
 J7-6 Green-Brown, Sw. Col. 1 to Cabinet  
 J7-7 Not Used  
 J7-8 Not Used  
 J7-9 Not Used  
 J7-10 Not Used  
 J7-11 White-Orange, Sw. Row 3 to Cabinet  
 J7-12 Not Used  
 J7-13 Not Used

J8-1 White, Sw. Row to Cabinet Slam Tilt  
 J8-2 Key  
 J8-3 Green, Sw. Col. to Cabinet Slam Tilt

J9-1 White-Yellow, Sw. Row 4 to Plumb Bob Tilt  
 J9-2 Key  
 J9-3 Green-Brown, Sw. Col. 1 to Plumb Bob Tilt  
 J9-4 White-Red, Sw. Row 2 to Interlock Sw.  
 J9-5 Green-Red, Sw. Col. 2 to Interlock Sw.

# COIN DOOR INTERFACE BOARD SCHEMATIC A-20580

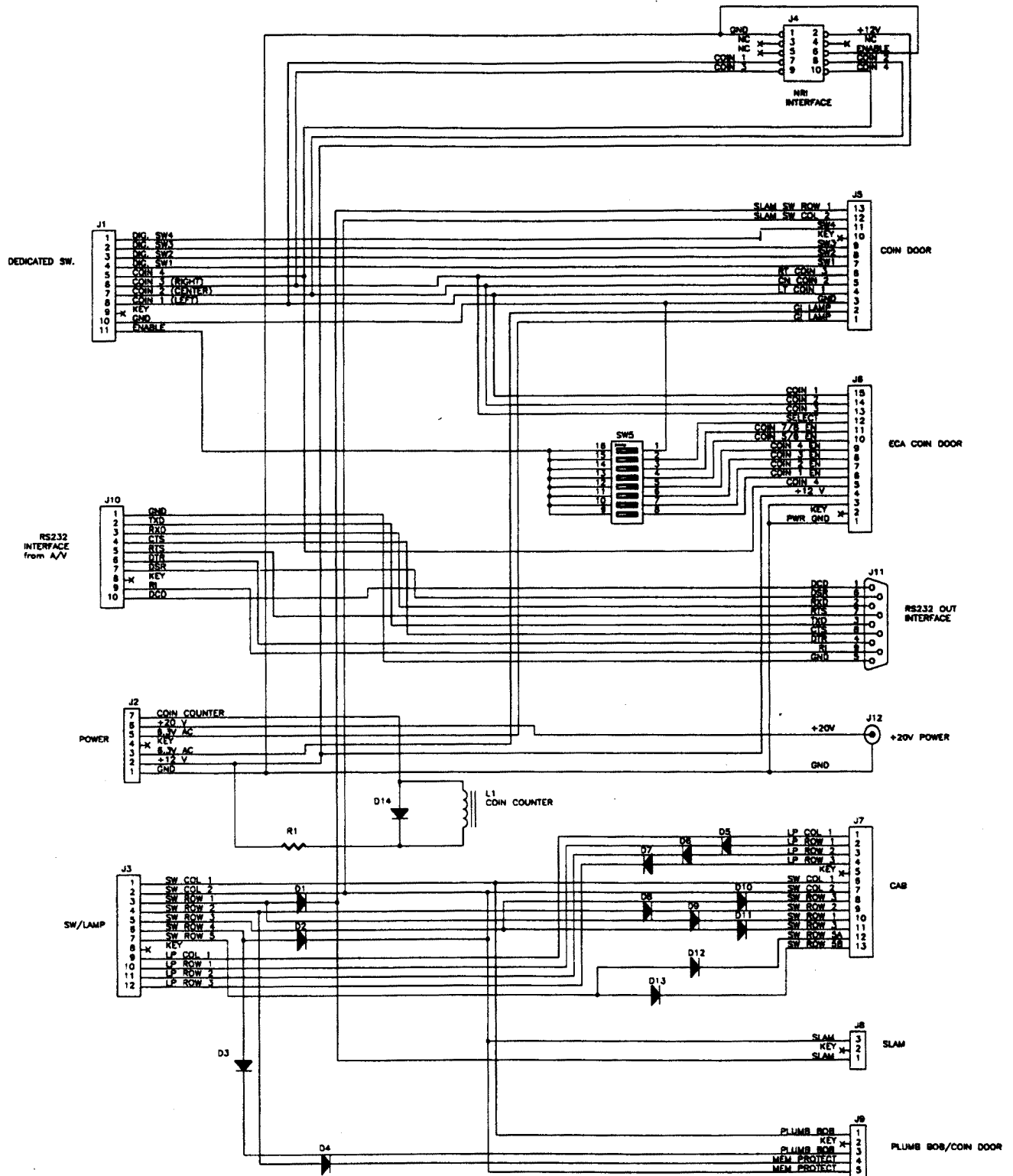

## Notes

A series of 25 horizontal dotted lines for writing notes.

## NOTES







# LAMP MATRIX

Column Row	Yellow (B+) 							
	1 Yellow-Brown J121-1 Q96	2 Yellow-Red J121-2 Q100	3 Yellow-Orange J121-3 Q95	4 Yellow-Black J121-4 Q99	5 Yellow-Green J121-5 Q94	6 Yellow-Blue J121-8 Q98	7 Yellow-Violet J121-7 Q93	8 Yellow-Gray J121-9 Q97
1 Red-Brown J125-1 Q104	STIFF LEVEL 7 11	STIFF LEVEL 8 21	CRATE LEFT EYE 31	LEFT LEAPER 41	RAMP ITEM 51	LABORATORY ITEM 61	WEB AWARD 7 71	WEB AWARD 15 81
2 Red-Black J125-2 Q108	STIFF LEVEL 6 12	STIFF LEVEL 9 22	CRATE CENTER LEFT 32	LEFT RAMP JACKPOT 42	COFFIN MULTIBALL ITEM 52	CRATE ITEM 62	WEB AWARD 8 72	WEB AWARD 16 82
3 Red-Orange J125-4 Q103	STIFF LEVEL 5 13	SCARED STIFF 23	CRATE CENTER RIGHT 33	LIGHT LOCK 43	LEAPER ITEM 53	SKULL ITEM 63	WEB AWARD 9 73	WEB AWARD 1 83
4 Red-Yellow J125-5 Q107	STIFF LEVEL 4 14	CENTER LEAPER 24	CRATE RIGHT EYE 34	RAMP RIGHT EYE 44	COFFIN SPOTLIGHT 54	WEB AWARD 2 64	WEB AWARD 10 74	LEFT SKULL LANE 84
5 Red-Green J125-6 Q102	STIFF LEVEL 3 15	THREE BANK LOWER 25	LEFT OUTLANE 35	RIGHT OUTLANE 45	SHOOT AGAIN 55	WEB AWARD 3 65	WEB AWARD 11 75	CENTER SKULL LANE 85
6 Red-Blue J125-7 Q106	STIFF LEVEL 2 16	THREE BANK MIDDLE 26	RIGHT LEAPER 36	SKILL SHOT 46	LOCK LAMP 56	WEB AWARD 4 66	WEB AWARD 12 76	RIGHT SKULL LANE 86
7 Red-Violet J125-8 Q101	STIFF LEVEL 1 17	THREE BANK UPPER 27	RIGHT RAMP JACKPOT 37	CRATE JACKPOT 47	LEFT LOOP CENTER 57	WEB AWARD 5 67	WEB AWARD 13 77	BUY IN 87
8 Red-Gray J125-9 Q105	RAMP LEFT EYE 18	SPIDER POPPER 28	LIGHT SPIN SPIDER 38	EXTRA BALL 48	LEFT LOOP UPPER 58	WEB AWARD 6 68	WEB AWARD 14 78	START BUTTON 88

J1XX = Power Driver Board

# SWITCH MATRIX

Dedicated Grounded Switches	Column Row	White 								Green 	Flipper Grounded Switches
		1 Green-Brown J206-1 U20-18	2 Green-Red J206-2 U20-17	3 Green-Orange J206-3 U20-16	4 Green-Yellow J206-4 U20-15	5 Green-Black J206-5 U20-14	6 Green-Blue J206-6 U20-13	7 Green-Violet J206-7 U20-12	8 Green-Gray J206-9 U20-11		
Orange-Brown J205-1 U17-5 Left Coin Chute D1	White-Brown J208-1 U18-11	NOT USED 11	SLAM TILT 21	TROUGH EJECT 31	COFFIN LEFT 41	LEFT SLINGSHOT 51	THREE BANK UPPER 61	LEFT SKULL LANE 71	NOT USED 81	Black-Green J208-13 Lower Right Flipper EOS F1	
Orange-Red J205-2 U17-7 Center Coin Chute D2	White-Red J208-2 U18-9	WHEEL INDEX 12	COIN DOOR CLOSED 22	TROUGH BALL 1 32	COFFIN CENTER 42	RIGHT SLINGSHOT 52	THREE BANK MIDDLE 62	CENTER SKULL LANE 72	NOT USED 82	Blue-Violet J212-12 Lower Right Flipper Opto F2	
Orange-Black J205-3 U17-11 Right Coin Chute D3	White-Orange J208-3 U18-5	START BUTTON 13	BUY IN BUTTON 23	TROUGH BALL 2 33	COFFIN RIGHT 43	UPPER JET 53	THREE BANK LOWER 63	RIGHT SKULL LANE 73	NOT USED 83	Black-Blue J208-12 Lower Left Flipper EOS F3	
Orange-Yellow J205-4 U17-9 4th Coin Chute D4	White-Yellow J208-4 U18-7	PLUMB BOB TILT 14	ALWAYS CLOSED 24	TROUGH BALL 3 34	LEFT RAMP ENTER 44	CENTER JET 54	LEFT LEAPER 64	SECRET PASSAGE 74	NOT USED 84	Blue-Gray J212-11 Lower Left Flipper Opto F4	
Orange-Green J205-6 U16-9 Normal Function Ser Credits Test Function Esc D5	White-Green J208-5 U19-11	NOT USED 15	EXTRA BALL LANE 25	TROUGH BALL 4 35	RIGHT RAMP ENTER 45	LOWER JET 55	CENTER LEAPER 65	NOT USED 75	NOT USED 85	Black-Violet J208-11 Upper Right Flipper EOS F5	
Orange-Blue J205-7 U16-11 Normal Function Vol Down Test Function Down D6	White-Blue J208-7 U19-9	KICKBACK 16	LEFT FLIPPER LANE 26	RIGHT POPPER 36	LEFT RAMP MADE 46	UPPER SLINGSHOT 56	RIGHT LEAPER 66	NOT USED 76	NOT USED 86	Black-Yellow J212-10 Upper Right Flipper Opto F6	
Orange-Violet J205-8 U16-7 Normal Function Vol Up Test Function Up D7	White-Violet J208-8 U19-5	RIGHT FLIPPER LANE 17	RIGHT OUTLANE 27	LEFT KICKOUT 37	RIGHT RAMP MADE 47	CRATE SENSOR 57	LEFT RAMP 10 POINT 67	NOT USED 77	NOT USED 87	Black-Gray J208-10 Upper Left Flipper EOS F7	
Orange-Gray J205-9 U16-5 Normal Function Begin Test Test Function Enter D8	White-Gray J208-9 U19-7	SHOOTER LANE 18	SINGLE STANDUP 28	CRATE ENTRANCE 38	COFFIN ENTRANCE 48	LEFT LOOP 58	RIGHT LOOP 68	NOT USED 78	NOT USED 88	Black-Blue J212-9 Upper Left Flipper Opto F8	

J2XX = CPU Board;

= Opto, Typically Closed

## WARNINGS & NOTICES

### **WARNING**

**FOR SAFETY AND RELIABILITY**, substitute parts and equipment modifications are not recommended. Use of Non-BALLY parts or modifications of game circuitry, may adversely affect game play, or may cause injuries.

**SUBSTITUTE PART OR EQUIPMENT MODIFICATIONS** may void FCC/Canada Type Acceptance.

**BECAUSE THIS GAME IS PROTECTED** by Federal copyright, trademark, and patent laws, unauthorized game conversions may be illegal under Federal law.

**THIS 'CONVERSION' PRINCIPLE ALSO APPLIES** to unauthorized facsimiles of BALLY equipment, logos, designs, publications, assemblies and games (or game feature not deemed to be public domain), whether manufactured with BALLY components or not.

### **Notice**

MIDWAY® is a registered trademark of Midway Manufacturing Company. SCARED STIFF™ and BALLY® are trademarks used by Midway with permission. WILLIAMS, Lane-change and Multi-ball are trademarks of WILLIAMS Electronics Games, Inc. Entire contents of this manual ©1996 MIDWAY MANUFACTURING COMPANY, manufacturers of BALLY Amusement Games. All rights reserved.

## WARNING

**NOTE:** This equipment has been tested and found to comply with the limits for a Class A digital device, pursuant to Part 15 of the FCC Rules. These limits are designed to provide reasonable protection against harmful interference when the equipment is operated in a commercial environment. This equipment generated, uses, and can radiate radio frequency energy and if not installed and used in accordance with the instruction manual, may cause harmful interference to radio communications. Operation of this equipment in a residential area is likely to cause harmful interference in which case the user will be required to correct the interference at his own expense.

This Class B digital apparatus meets all requirements of the Canadian Interference-Causing Equipment Regulations.

Cet appareil numérique de la classe B respecte toutes les exigences du Règlement sur le matériel brouilleur du Canada.

### **RF Interference Notice**

CABLE HARNESS PLACEMENTS and ground strap routing on this game have been designed to keep RF radiation and conduction within levels accepted by the FCC Rules.

TO MAINTAIN THESE LEVELS, reposition harnesses and reconnect ground straps to their original placements, if they become disconnected during maintenance.

**FCC/CANADA STICKER.** Check the back of your game to verify that an FCC/Canada-certification sticker was attached to your game at the factory. All Games that leave the BALLY plant have been tested and found to comply with FCC/Canada Rules. Because the sticker is proof of this fact, legal repercussions to the owner and distributor may result, if the sticker is missing. If you receive a game that has no FCC/Canada sticker, call BALLY for advice or write us a note on your Game Registration Card. Be sure that the card bears your game's serial number.

**FOR SERVICE...**  
CALL your authorized  
BALLY Distributor

**MIDWAY Manufacturing Company**  
3401 N. California Avenue  
Chicago, IL 60618

Scared Stiff™ ©1996 Midway® Manufacturing Company. All rights reserved.  
Elvira®, Mistress of the Dark™, and all images, designs and likenesses of Elvira™ are trademarks of Queen "B" Productions.  
© 1996 Queen "B" Productions.

**CAUTION: Transport this game ONLY  
with hinged backbox DOWN!**