

# TERMINATOR 2

## JUDGMENT DAY



Operations Manual Includes  
Operations & Adjustments  
Testing & Problem Diagnosis  
Parts Information  
Wiring Diagrams & Schematics

**Williams Electronics Games, Inc.**

## Jumper Charts

<b>ROM</b>	W1	W2
1M / 2M	In	Out
512 / 1M	Out	In

<b>Country</b>	W14	W15	W16	W17	W18
American	In	In	In	In	In
European	In	In	Out	In	In
French	In	In	In	Out	In
German	In	In	In	In	Out

## Solenoid Table

Sol. No.	Function	Solenoid Type	Wire Color	Connections Playfield-Insert	Driver Trnstr	Solenoid Part Number Flashlamp Type
01	Ball Popper	High Power	Vio-Brn	J130-1	Q82	AE-23-800
02	Gun Kicker	High Power	Vio-Red	J130-2	Q80	AE-24-900
03	Outhole	High Power	Vio-Orn	J130-4	Q78	AE-27-1200
04	Trough	High Power	Vio-Yel	J130-5	Q76	AE-26-1200
05	Right Sling	High Power	Vio-Grn	J130-6	Q64	AE-26-1500
06	Left Sling	High Power	Vio-Blu	J130-7	Q66	AE-26-1500
07	Knocker	High Power	Vio-Blk	J130-8	Q68	AE-23-800
08	Kickback	High Power	Vio-Gry	J130-9	Q70	AE-23-800
09	Plunger	Low Power	Brn-Blk	J127-1	Q58	AE-23-800
10	Top Lock	Low Power	Brn-Red	J127-3	Q56	AE-26-1500
11	Gun Motor	Low Power	Brn-Orn	J127-4	Q54	14-7963
12	Knock Down	Low Power	Brn-Yel	J127-5	Q52	SM1-26-600
13	Left Jet	Low Power	Brn-Grn	J127-6	Q50	AE-26-1200
14	Right Jet	Low Power	Brn-Blu	J127-7	Q48	AE-26-1200
15	Bottom Jet	Low Power	Brn-Vio	J127-8	Q46	AE-26-1200
16	Left Lock	Low Power	Brn-Gry	J127-9	Q44	AE-26-1500
17	Hot Dog Flashlamps	Flasher	Blk-Brn	J126-1	Q42	#906 (4 PL)
18	Right Sling Flashlamps	Flasher	Blk-Red	J126-2	Q40	#906 (1 BB), #89 (1 PL)
19	Left Sling Flashlamps	Flasher	Blk-Orn	J126-3	Q38	#906 (1 BB), #89 (1 PL)
20	Left Lock Flashlamps	Flasher	Blk-Yel	J126-4 J125-2	Q36	#906 (1 BB), #89 (1 PL)
21	Gun Flashlamps	Special	Blu-Grn	J126-5 J125-3	Q28	#89 (2 PL)
22	Right Ramp Flashlamps	Special	Blu-Blk	J126-6 J125-5	Q30	#906 (1 BB), #89 (1PL)
23	Left Ramp Flashlamps	Special	Blu-Vio	J126-7	Q34	#906 (1 BB), #89 (1 PL)
24	Backglass Flashlamp	Special	Blu-Gry	J125-7	Q32	#906 (1 BB)
25	Targets Flashlamps	Special	Blu-Brn	J122-1 J125-8	Q26	#89 (2 PL)
26	Left Popper Flashlamps	Special	Blu-Red	J122-2 J125-9	Q24	#89 (2 PL)
27	Right Popper Flashlamps	Special	Blu-Orn	J122-3	Q22	#89 (2 PL)
28	Flashlamps Drop Target	Special	Blu-Yel	J122-4	Q20	AE-26-1200
01	<b>General Illumination</b>					
02	Top Insert G.I.	G.I.	Wht-Brn	J120-7	Q18	#555
03	Left Playfield G.I.	G.I.	Wht-Vio	J119-1	Q10	#555
04	Right Playfield G.I.	G.I.	Wht-Yel	J121-9	Q14	#555
05	Not Used	G.I.	Wht-Orn	J120-8	Q16	
	Bottom Insert G.I.	G.I.	Wht-Grn	J120-10	Q12	#555
	Lower Right Flipper		Blu-Yel	J109-7		FL-11630
	Lower Left Flipper		Gry-Yel	J109-5		FL-11630

Williams Electronics Games, Inc. reserves the right to make modifications and improvements to its product.

The specifications and parts identified in this manual are subject to change without notice.

# Contents

Rules & Playfield Shots .....	A thru N
<b>Section 1 - Game Operation &amp; Test Information</b>	
(System WPC) ROM Summary .....	1-1
Pinball Game Assembly Instructions .....	1-2
Figure 1. Pinball Assembly, Playfield Pitch Angle, and Leg Levelers Detail .....	1-2
Gun Handle Assembly .....	1-4
Game Control Locations .....	1-5
Figure 2. Pinball Game Control Locations .....	1-5
Game Operation .....	1-6
Menu System Operation .....	1-8
Main Menu .....	1-9
Adjustment Menu .....	1-9
Standard Adjustments Menu .....	1-9
Feature Adjustments .....	1-13
Pricing Adjustments .....	1-15
Pricing Table .....	1-17
H.S.T.D. Adjustments .....	1-18
Printer Adjustments .....	1-19
Bookkeeping Menu .....	1-20
Main Audits .....	1-20
Earnings Audits .....	1-21
Standard Audits .....	1-21
Feature Audits .....	1-22
Histograms .....	1-23
Time-Stamps .....	1-23
Printouts Menu .....	1-24
Test Menu .....	1-25
Switch Edges, Switch Levels & Single Switch Tests .....	1-25
Switch Matrix Table & Schematic .....	1-26
Solenoid Test .....	1-27
Flasher Test .....	1-27
Solenoid Table .....	1-28
High & Low Power Solenoid Circuits .....	1-29
Special Solenoid & Flashlamp Circuits .....	1-30
General Illumination Test .....	1-31
Sound and Music Test .....	1-31
Single Lamp, All Lamp, and Flasher and Lamp Test .....	1-32
Lamp Matrix & Schematic .....	1-33
Display Test .....	1-34
Gun Test .....	1-34
Utilities Menu .....	1-35
Clear Audits & Coins, Reset H.S.T.D & Time-Date, Message, Game I.D. .....	1-35
Factory Adjusts, Factory Reset & Setting Table, Presets .....	1-36
Game Difficulty Table for U.S./Canadian & French Games .....	1-37
Game Difficulty Table for German/European Games .....	1-37
Preset U.S./Canadian Games, Install Add-A-Ball, Ticket .....	1-38
Install Novelty, Buy-in .....	1-39
Preset German Games .....	1-40
Preset French Games, Clear Credits, Auto Burn-in .....	1-41
Problem Analysis .....	1-42
CPU Board & Sound Board Error Codes .....	1-43
Maintenance Information .....	1-44
Fuse List .....	1-45
L.E.D. List .....	1-46

# Contents

## Section 2 - Game Parts Information

Cabinet Parts .....	2-2
Backbox Assembly .....	2-3
Location Diagram .....	2-4
Audio Board .....	2-5
CPU Board .....	2-6
Power Driver Board .....	2-8
Dot Matrix Controller Board .....	2-10
Coin Door Interface & Motor Regulator Boards .....	2-12
Lamp Boards .....	2-13
Flippers .....	2-14
Shooter Lane Feeder & Outhole Kicker .....	2-16
Kicker (sling) Assembly .....	2-17
Jet Bumper Assembly .....	2-18
Trough Switches .....	2-19
Kickback Assemblies .....	2-20
Ball Eject Assembly .....	2-21
Ball Popper & Stand-up Switches .....	2-22
1 Bank Drop Target .....	2-23
Gun Platform Assembly .....	2-24
Platform & Kicker Assembly .....	2-25
Gun Handle .....	2-26
Skull Assembly .....	2-27
Coin Door .....	2-28
Posts .....	2-29
Unique Parts .....	2-31
Playfield Parts List .....	2-32
Playfield Parts Location .....	2-33
Lamp Matrix .....	2-34
Lamp Locations .....	2-35
Switch Matrix .....	2-36
Switch Locations .....	2-37
Solenoid Table .....	2-38
Solenoid Locations .....	2-39
Rubber Rings Parts & Locations .....	2-40

## Section 3 - Wiring Diagrams And Schematics

Connector & Component Identification .....	3-1
Flipper Wiring .....	3-2
Coin Door Interface Board .....	3-3
Motor Regulator Board .....	3-4
Motor EMI Filter Board .....	3-5
Solenoid Wiring .....	3-6
Switch & Lamp Interboard Wiring .....	3-7
Solenoid & Flipper Interboard Wiring .....	3-8
General Illumination, Power & Logic Interboard Wiring .....	3-9
Display & Sound Interboard Wiring .....	3-10

# **Terminator 2 Judgment Day**

**Playfield Shot Maps  
&  
Rules**

# ***Terminator 2 Judgment Day Rules***

## **Skill Shot**

Pull the trigger and hit a Moving Target Light.

## **Ramps**

Shoot alternate ramps to advance Security Levels to Payback Time.

## **Payback Time**

Hitting 5 Flashing Target scores 5 million each.

## **Multi-ball**

Shoot the Drop Target to load the Cannon. Pull the Trigger to shoot the ball at the Lit Targets.

## **Jackpot & Super Jackpot**

During Multi-ball, lock balls to multiply Jackpot. Pull the Trigger to shoot a ball at the Lit Targets.

## **Chase Loop**

Consecutive Chase Loop shots advance value and Millions.

## **Escape Route**

Shoot Red 3 Bank Target to advance value. Shoot Top Eject to collect lit value consecutively.

## **Hurry Up**

Lit Left Return Lane starts Hurry Up. Shoot Right Loop Shot to collect Value.

## **Video Mode**

Lit Right Return Lane starts the Video Mode. Shoot the Left Loop Shot to play the Video Mode.

## Terminator 2 Skill Shot

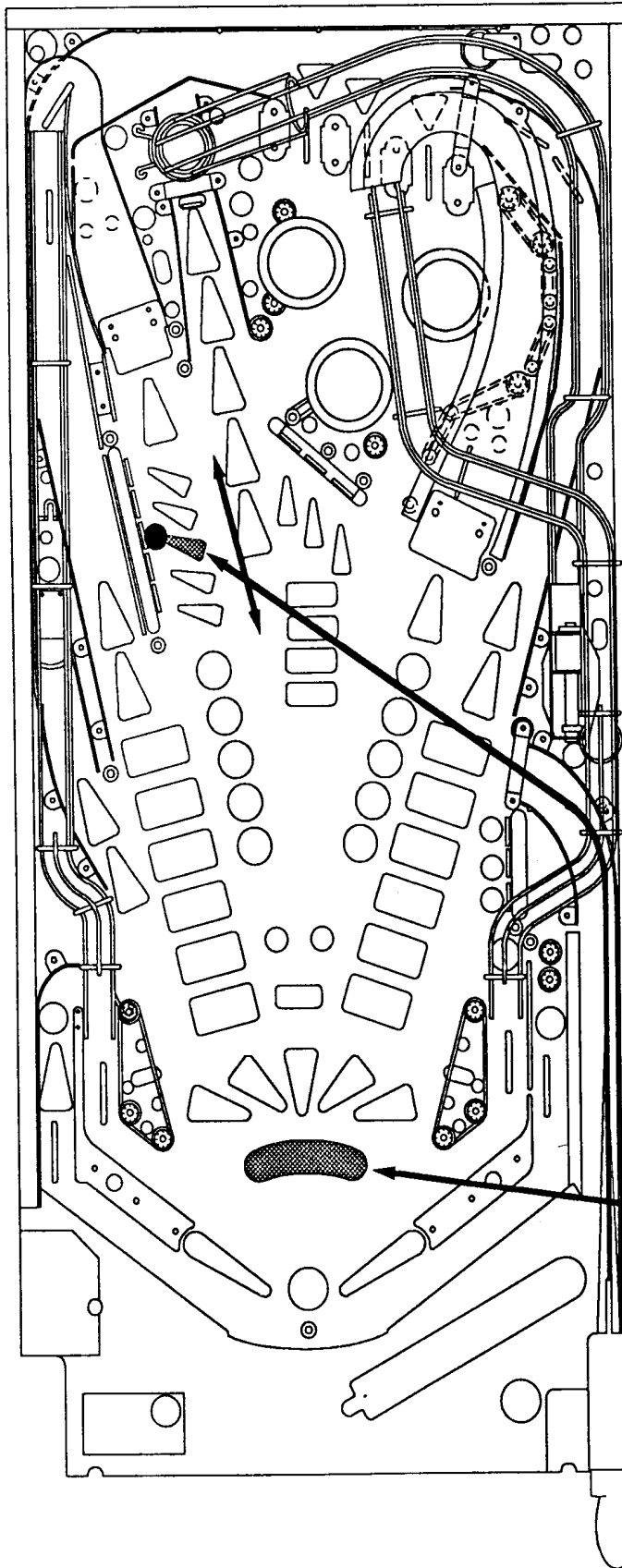

Pull Trigger to fire ball into 5  
Targets. Hit LIT MOVING  
TARGET to get Highest Score.  
1st ball = 1, 000, 000  
2nd ball = 2, 000, 000  
3rd ball = 3, 000, 000  
4th ball = 4, 000, 000  
etc.

Note: At the beginning of ball's  
play , "AUTOFIRE" (Drain  
Protection) is lit. See page E for  
more information on  
"AUTOFIRE".

Autofire Lamp

Gun Grip  
Pull Trigger to Fire a Ball  
Onto the Playfield

## Terminator 2 Ramp Shots and Payback Time

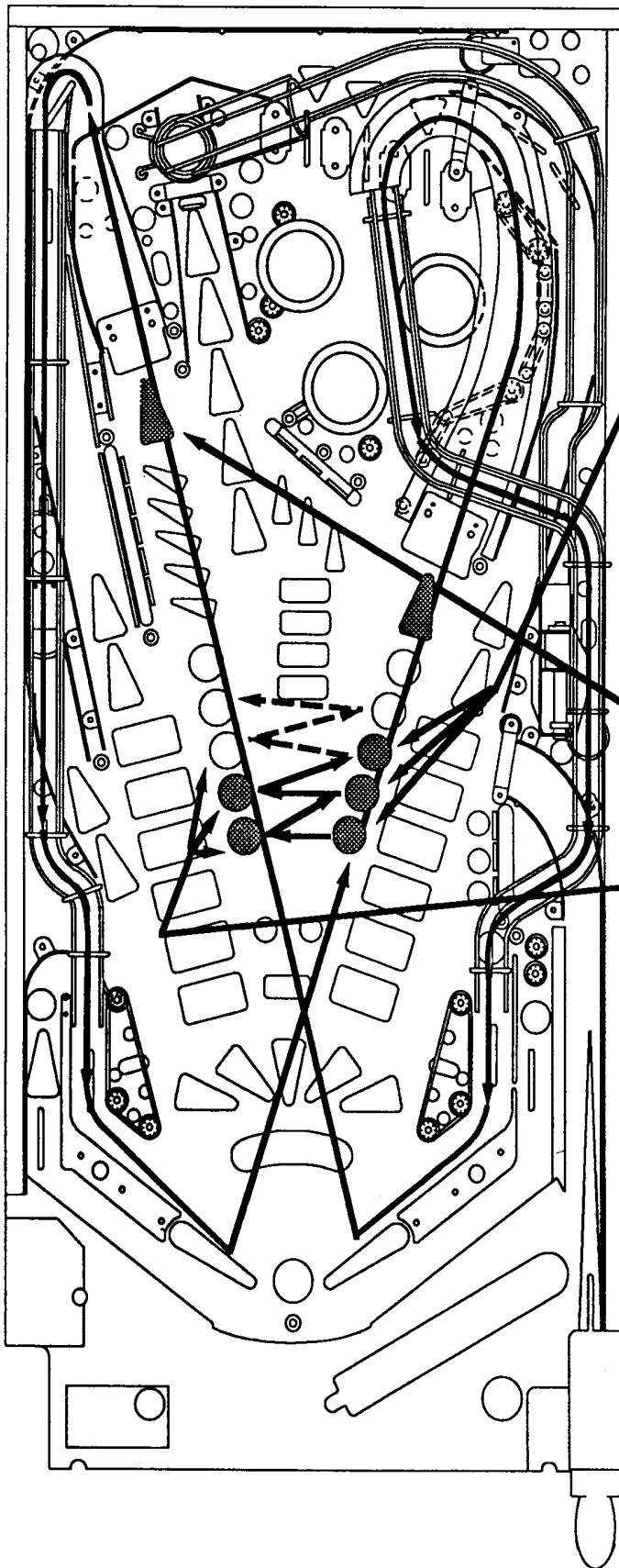

Shooting RAMP SHOTS with RED ARROWS LIT advances "Security Level" Lights as shown.

When RED ARROWS are LIT, corresponding ramp scores, "Security Level" Lamp. When either Red arrow is FLASHING, ramp value is 1, 000, 000 and Advance "Security Level".

Shooting up LEFT Ramp FLASHES RED ARROW in front of RIGHT Ramp for apx. 2 seconds. The opposite occurs when a ball is shot up the RIGHT Ramp; The Red Arrow in front of the LEFT Ramp FLASHES.

Making Left-Right-Left-etc, ramp shots in quick alternating succession gives the player the opportunity to score millions and advance to "Payback Time" much quicker than random ramp shots.



## Terminator 2 Payback Time

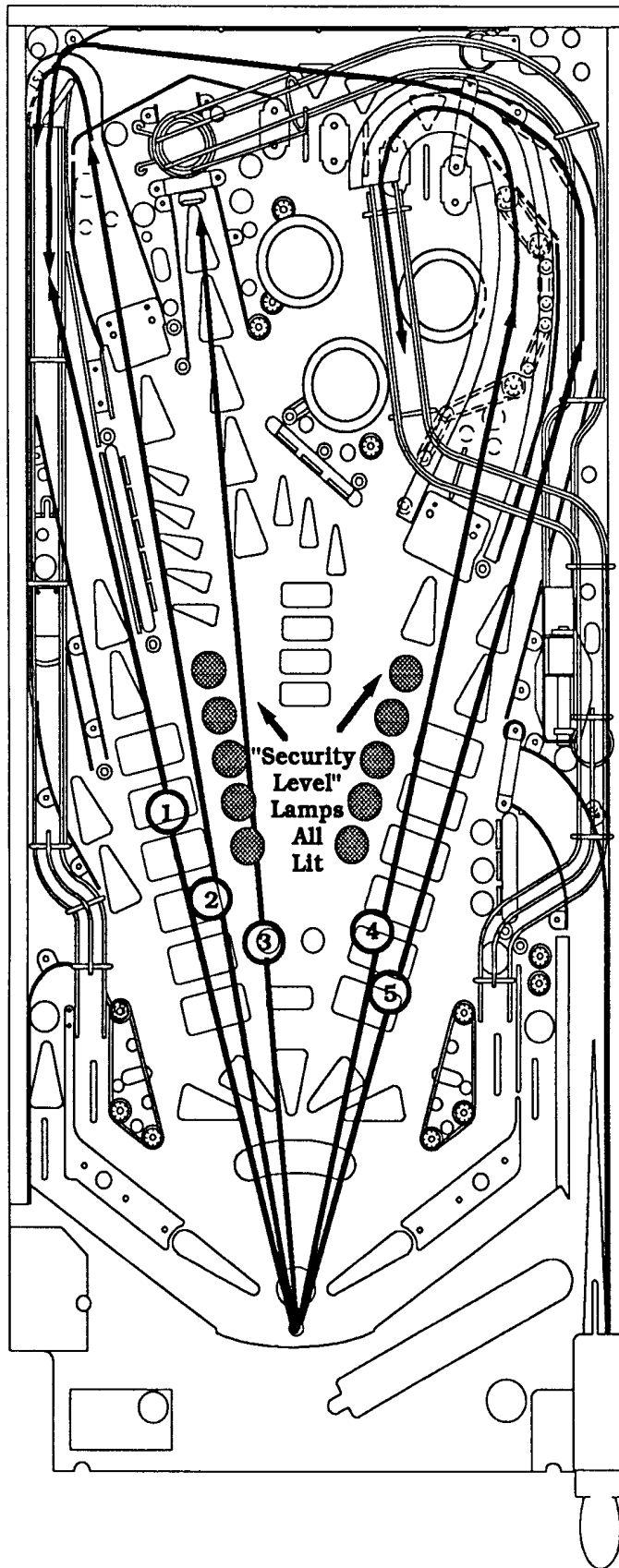

When a player has completed 10 LIT or FLASHING ramp shots (5 Left, 5 Right) during the course of a game, the game goes into a mode called "Payback Time".

During "Payback Time", the 5 shots shown and the Top Lanes award 5 Million points each. Any of the shots may be made repeatedly, and there is no required order.

## Terminator 2 Multi-ball

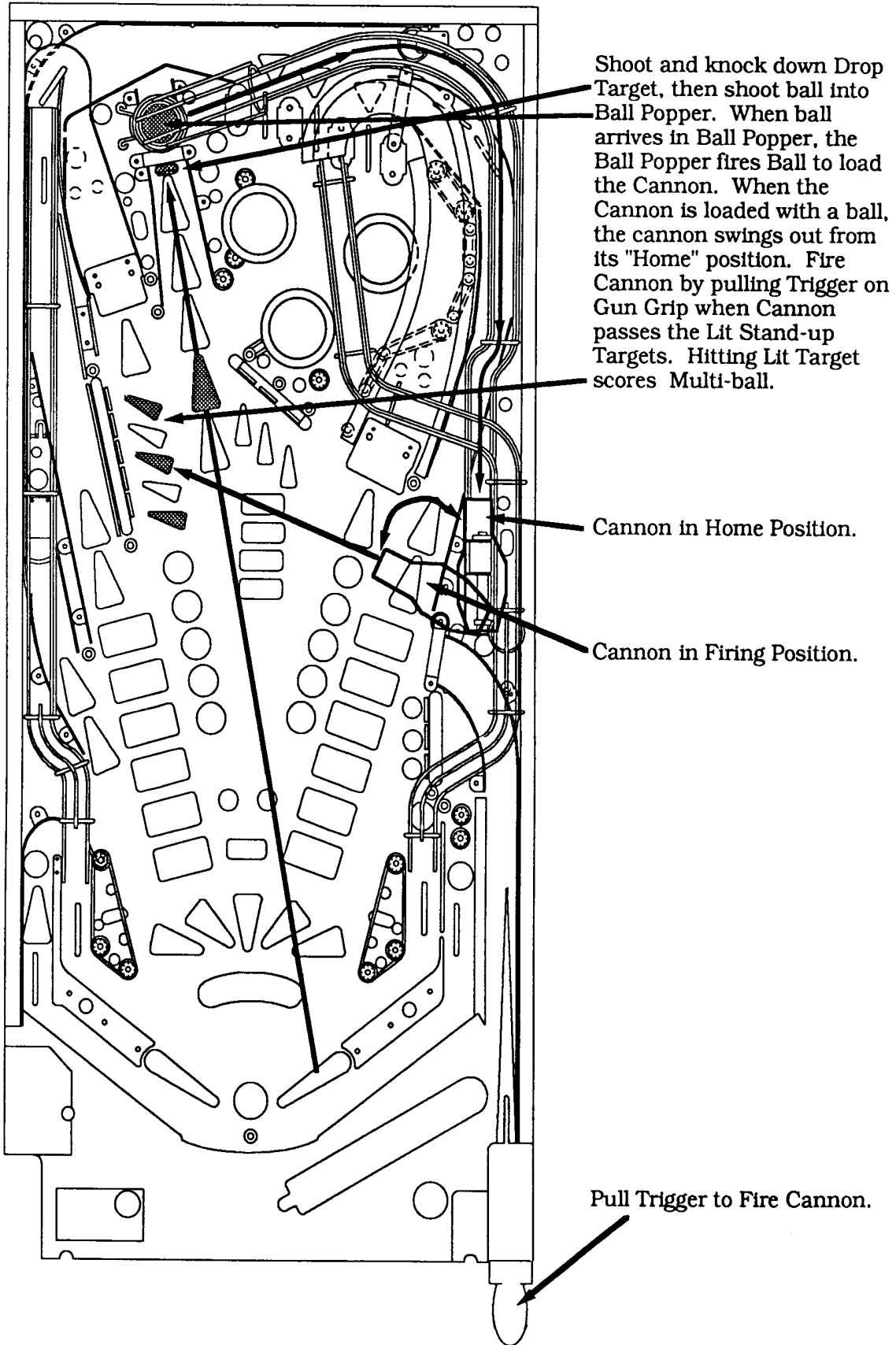

## Terminator 2 Multi-ball Continued

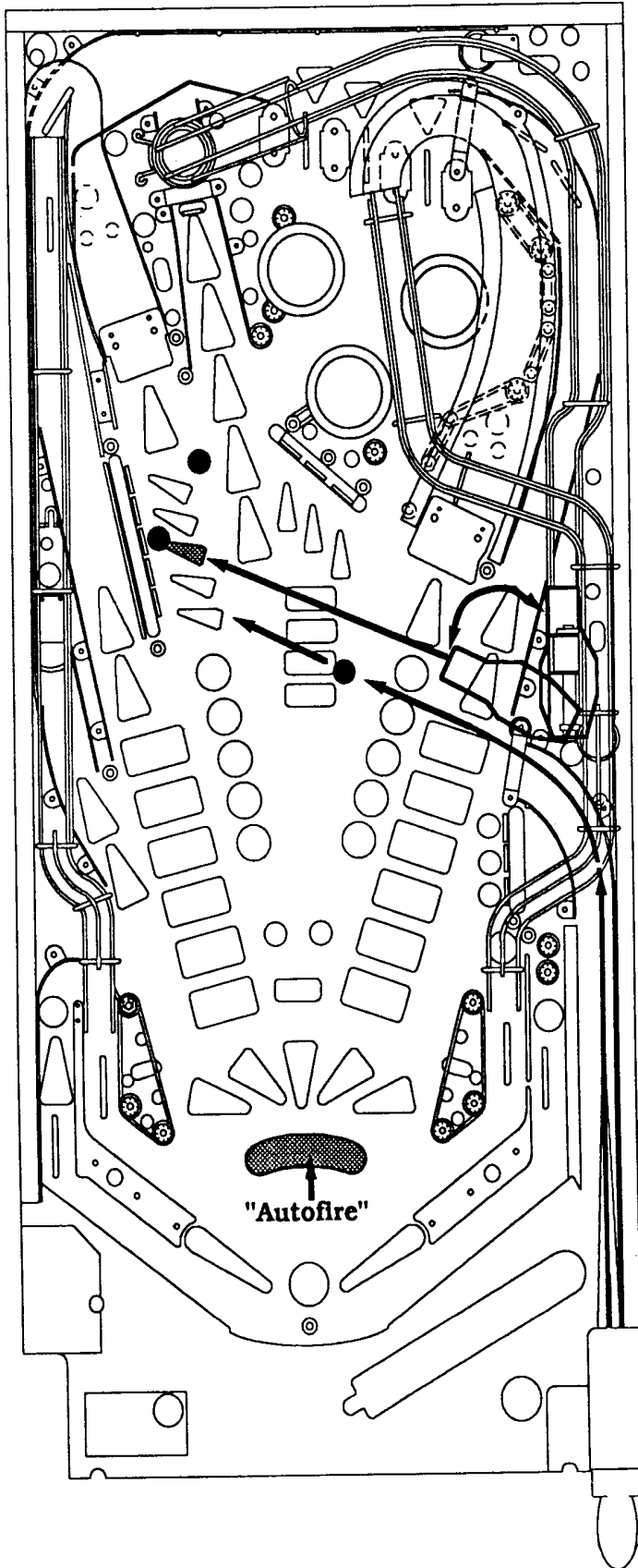

When Multi-ball is scored (by hitting Lit Target with accurate Cannon Shot), two balls are shot onto the playfield AUTOMATICALLY. For a short duration "Autofire" will be On. "Autofire" is a feature that AUTOMATICALLY saves a player's drained balls by throwing them back out onto the playfield. This is to prevent 5 second ball times from occurring. It is Especially important during Multi-ball when balls will be lost in just a few seconds typically.

## Terminator 2 Jackpot and Super Jackpot

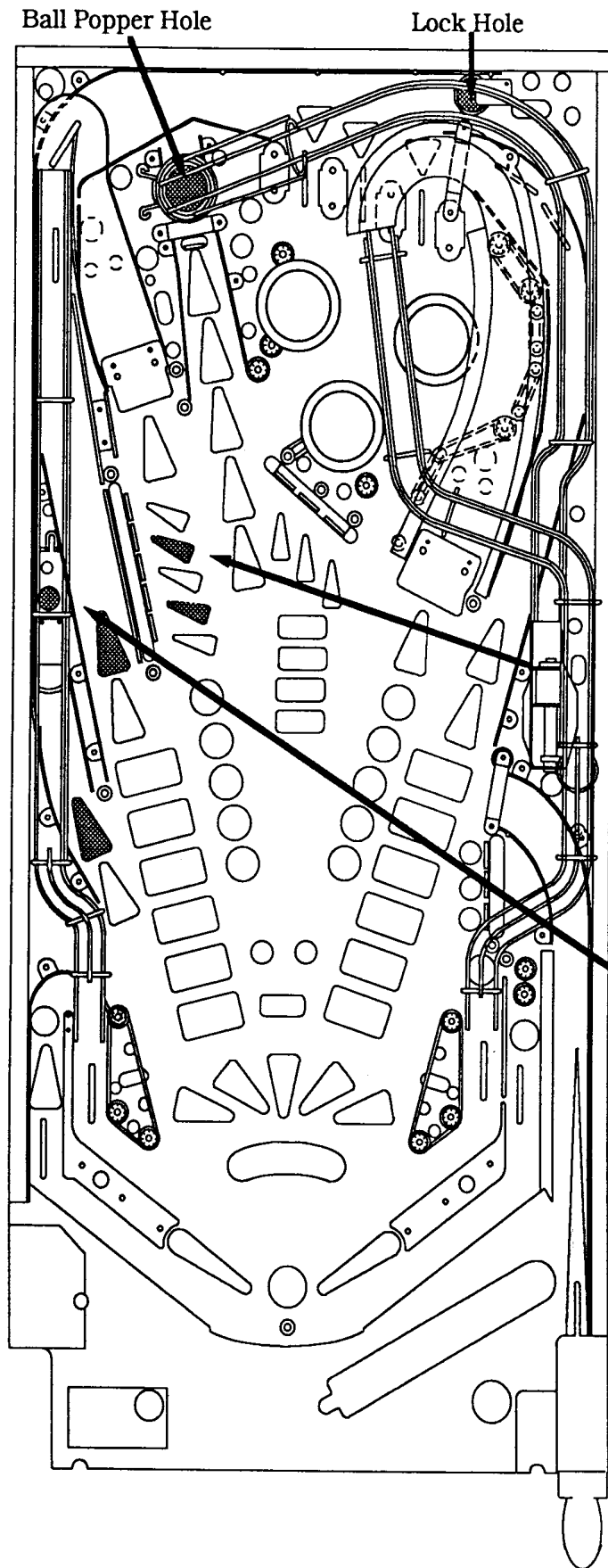

DURING MULTI-BALL, the object of the game is to achieve JACKPOT and SUPER JACKPOT, (50, 000, 000 points). The player must "Load the Cannon" by shooting a ball into the Ball Popper Hole. At this point the player is guaranteed an opportunity to shoot for a 1X Jackpot with the moving Cannon, but the Cannon will NOT be loaded until the other balls are drained or LOCKED in the Lock Holes: I.E., If the player has one ball in the Ball Popper, one ball locked and has drained a ball, he gets an opportunity to score a 2X Jackpot. If the player is able to lock 2 balls in the Lock Holes and 1 in the Ball Popper, he qualifies for a 3X Jackpot, (a possible 30 Million points).

Lock Hole

## Terminator 2 Jackpot and Super Jackpot Continued

2X Jackpot Scored (shown)

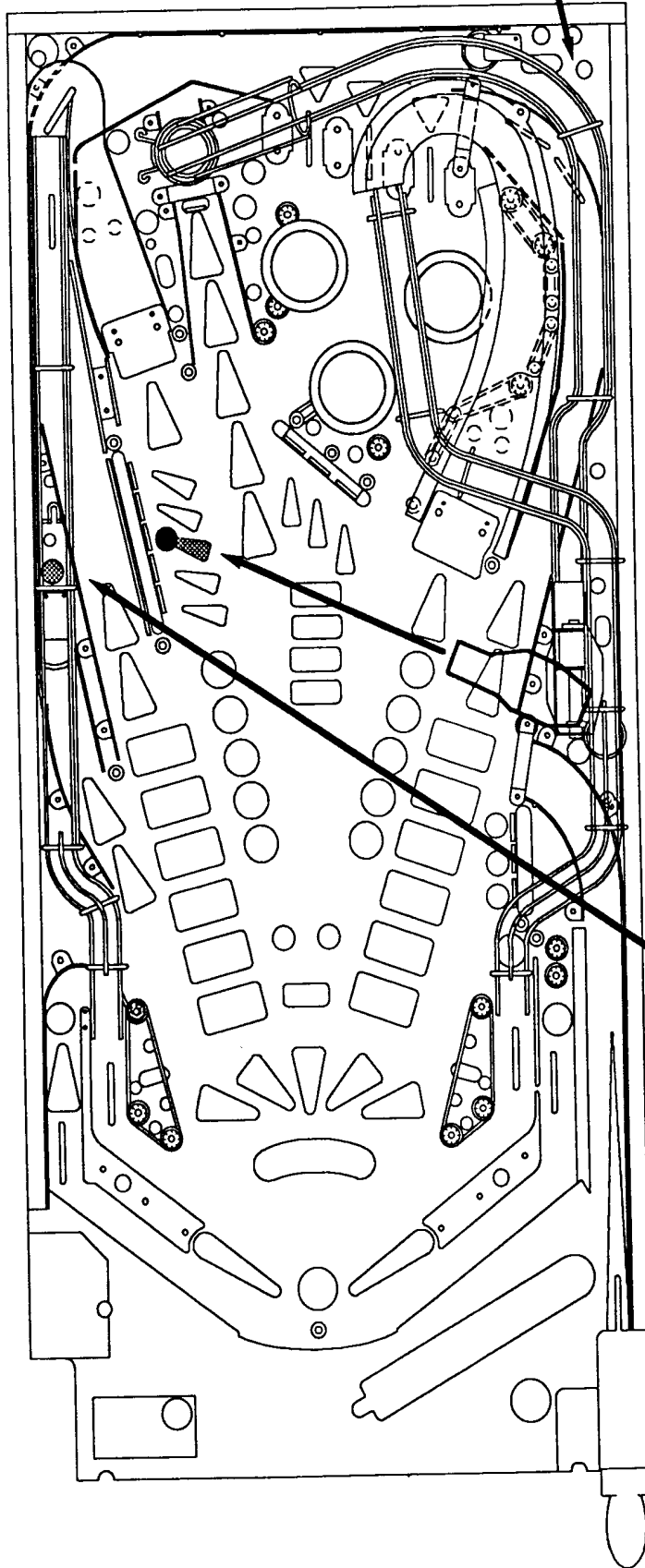

Regardless of the number of balls locked, the player must have 1 ball in the Ball Popper to qualify for a Jackpot. When the other 2 balls are either locked or drained, the game says "Get the Jackpot" the Ball Popper loads the Cannon and the Cannon swings out to aim at the targets. If the player shoots a lit target, then the player receives a 1X, 2X or 3X Jackpot depending on the number of locked balls as explained above. The balls are then kicked out and the player can attempt a SUPER JACKPOT.

Ball Locked  
in Lock Hole

## Terminator 2 Super Jackpot Continued

Going for Super Jackpot

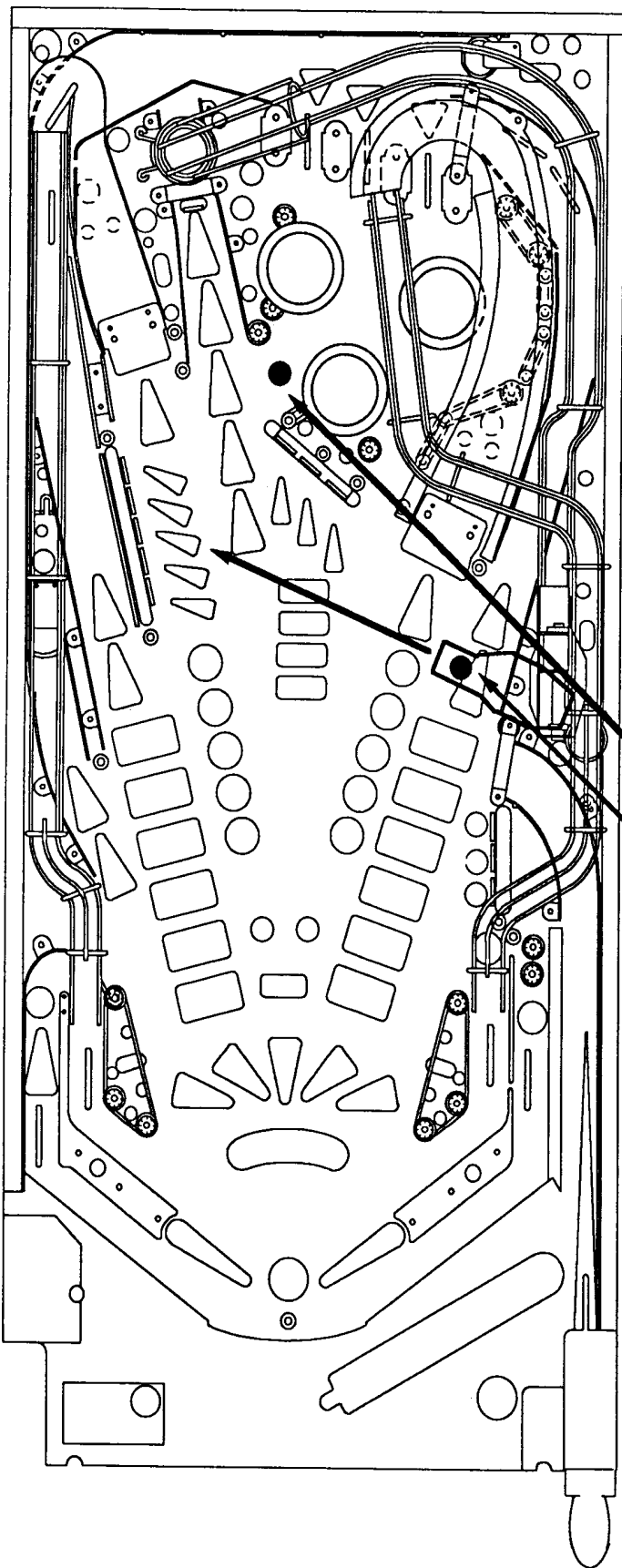

To qualify for Super Jackpot, the player must have succeeded in collecting at least a 2X Jackpot and have at least two balls in play on the playfield. The player must reload the Cannon with one of the balls in play. The game then says, "Get the Super Jackpot" and the ball is "popped" to load the Cannon. NOTE: Other balls cannot be locked during a Super Jackpot attempt. If the player succeeds in hitting a lit Stand-up Target, he scores 50,000,000 points. This score cannot be multiplied since no balls can be locked during Super Jackpot. Multiple Super Jackpots can be achieved by repeating the above requirements.

Ball in Play.

Ball in Cannon.

## Terminator 2 Chase Loop Feature

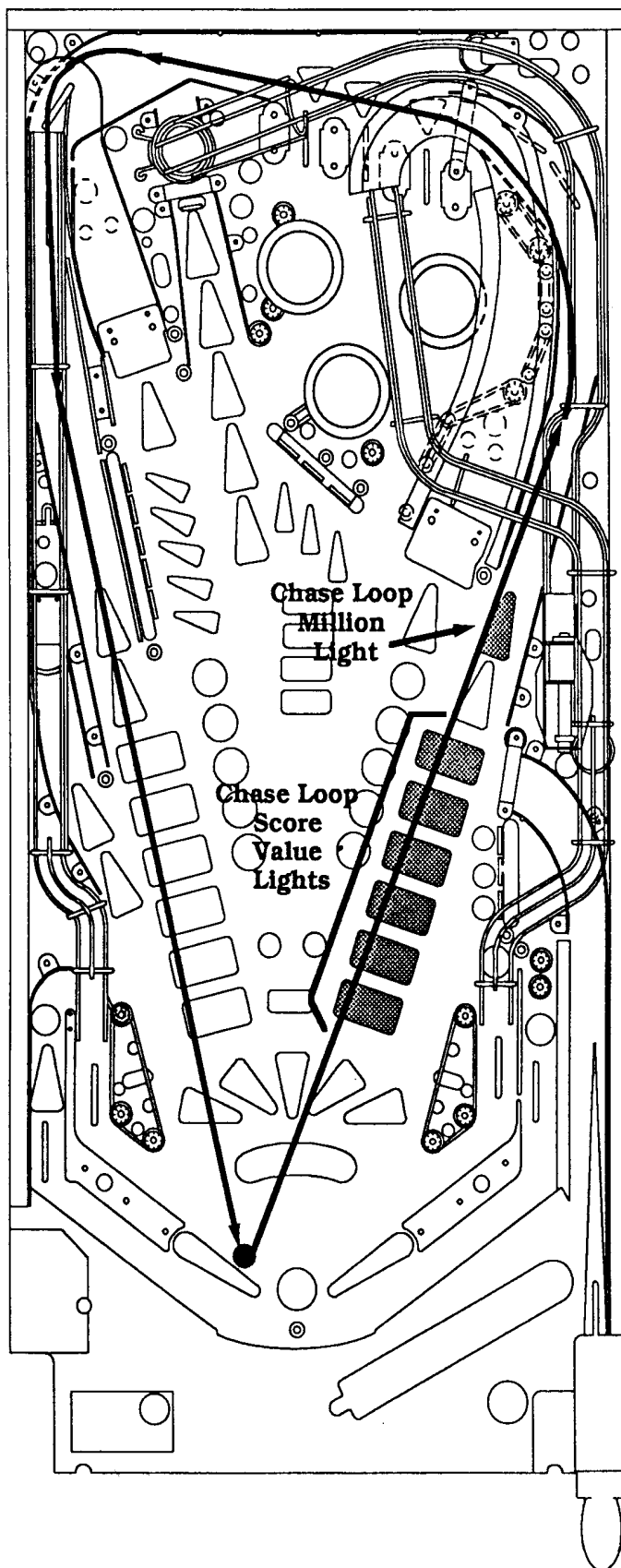

The game starts with the Chase Loop Score Value Lights (Red Rectangles on RIGHT side of the playfield) at the lowest value (250, 000 points) flashing. When the player shoots a ball around the Chase Loop once, he receives 250, 000 points, the next rectangle in the line begins flashing (500, 000 points) and the Chase Loop Million Light is flashing. If the player makes another consecutive Chase Loop shot, he receives 1, 000, 000 "Consecutive" Bonus points in addition to the 500, 000 points. Shown lit. If the player should make another Chase Loop shot immediately after the second, he scores 2, 000, 000 "Consecutive" Bonus points and 750, 000 shown lit.

The player can continue consecutively in this fashion to light the 5, 000, 000 value. Once the 5, 000, 000 light is lit, it remains lit and continues to award 5, 000, 000 points for Chase Loop shots for the remainder of that ball.

At the beginning of each ball the Chase Loop Value Lights return to the initial value of 250, 000 points. The player may also take occasional shots at the Chase Loop. Each shot continues to advance the value all the way to 5 Million. Additional Millions are not awarded unless "Consecutive" shots are made (2-3 seconds between shot completion).

## Terminator 2 Escape Route Feature

Top Kickout Hole

Red 3-bank of Stand-up Targets

10 Million scores 10 Million points when scored.

Extra Ball scores an Extra Ball when scored.

Multi-ball begins a standard Multi-ball when scored.

"Lite Flipper Lanes" lights Flipper Return Lanes to qualify Hurry-up (on Left) and Video Mode (on Right).

"Hold Bonus" holds over Bonus and Multiplier progress until next ball when scored.

"Security Pass" Lights 1 Security Level when scored.

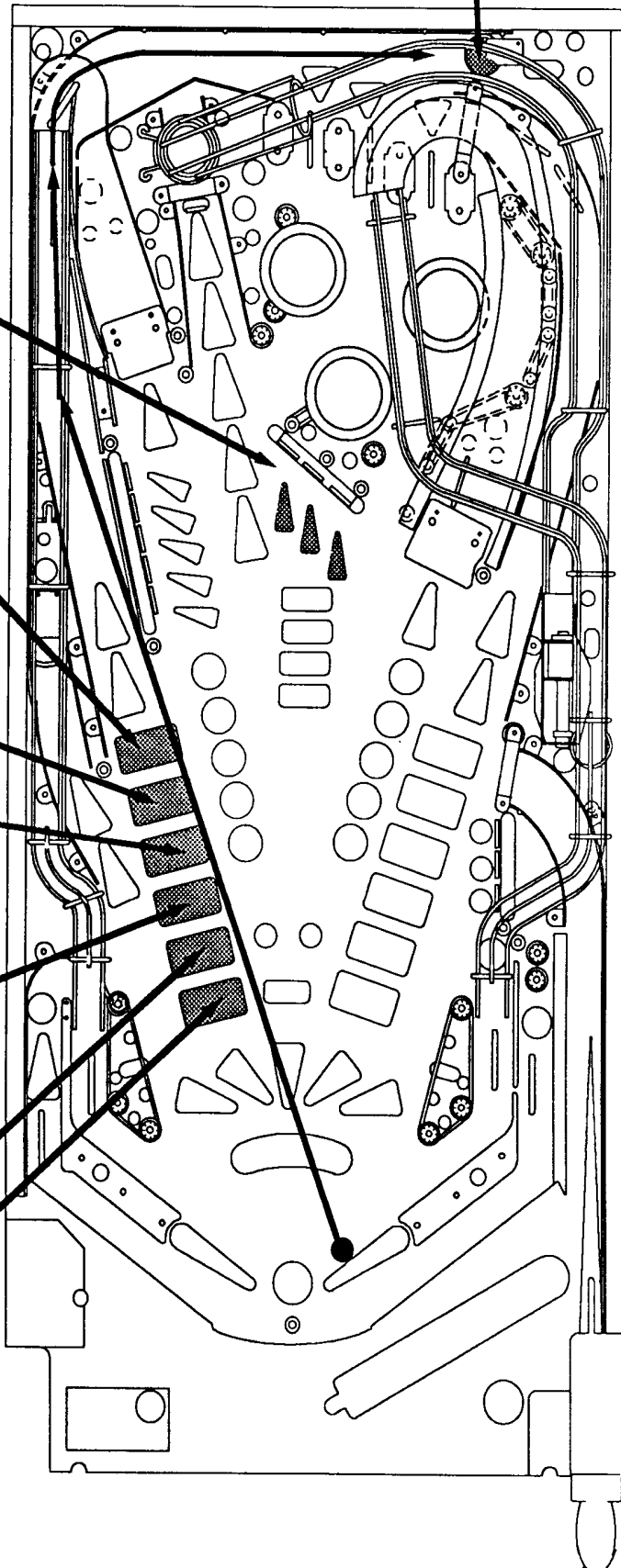

The Escape Route Feature consists of a row of six Rectangular Inserts on the left lower side of the playfield, the Kickout Hole at the top right of the playfield, and the Red 3-bank of Stand-up Targets in the middle of the playfield. Each time the player completes the Red 3-bank Targets, the Rectangle Features advance in an upward direction and are flashing. The player then shoots the ball in the Top Kickout Hole to collect the bottom-most flashing feature. It is possible to have all or some of the Rectangles flashing, but the player must shoot for the Top Kickout Hole to collect the values in an upward consecutive fashion.

The player has the entire game to light and collect these features because the game recalls the lit features from ball to ball. At the 4th Escape Route Feature (Extra Ball), the 3-bank of Stand-up Targets go to a liberal timer mode, forcing the player to complete the 3-bank before time runs out, and all Target Arrows go out. When the top value, or "10 Million" is collected, the feature starts over at the "Security Pass" level with a much more aggressive timer.



## Terminator 2 Database Feature

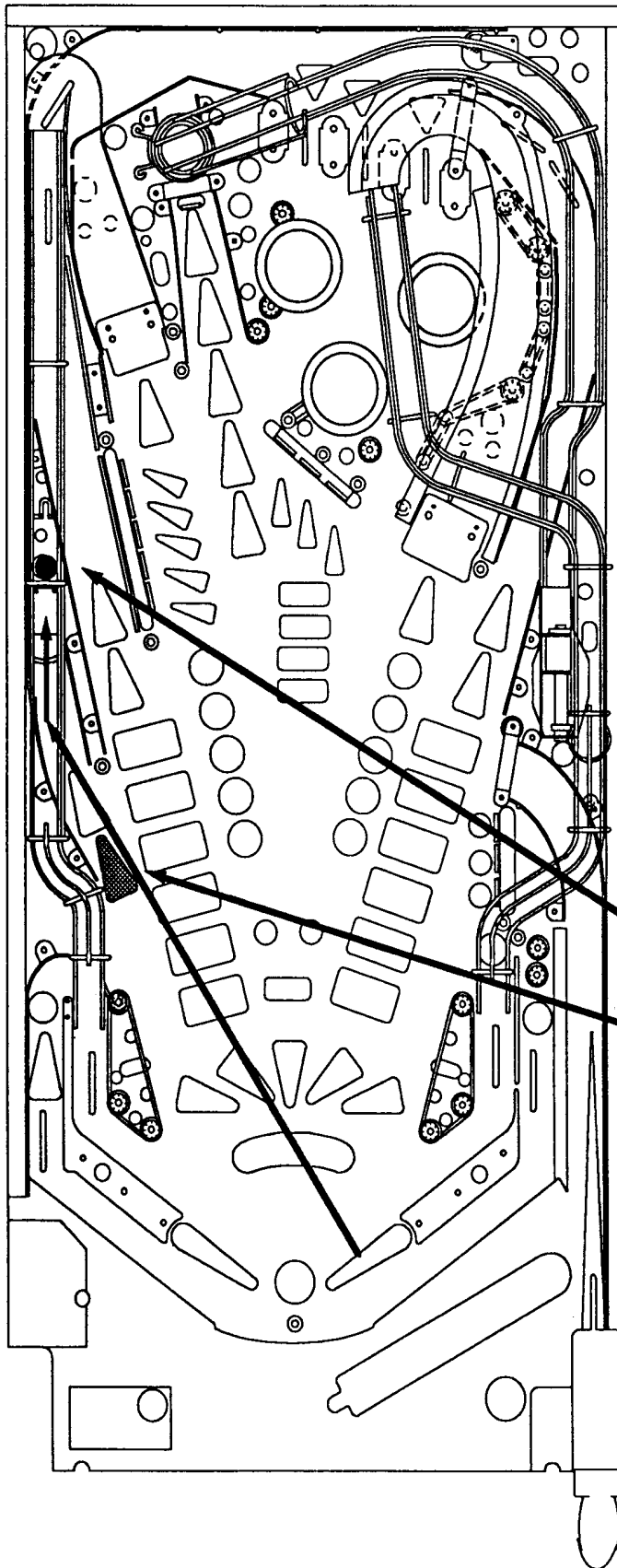

Database is a random feature that contains a possible 16 values that a player may collect "Randomly". When the Database light is lit, the player shoots the ball into the lower left Kickout Hole; the game pauses briefly for a display of "Terminator Thought" and selects one of 8 displayed values. The possible values are:

- 1) Extra Ball
- 2) Light Extra Ball
- 3) Light Hurry-up
- 4) Autofire
- 5) Special
- 6) Light Kickback
- 7) 3, 000, 000
- 8) Multi-ball
- 9) 500, 000
- 10) Video Mode
- 11) Chase Loop Advance
- 12) Security Level
- 13) Bonus X
- 14) Light Special
- 15) 1, 000, 000
- 16) Hurry-up

Lower Left Kickout Hole

Database Light

## Terminator 2 Bonus Multiplier

Bonus Multiplier Lanes

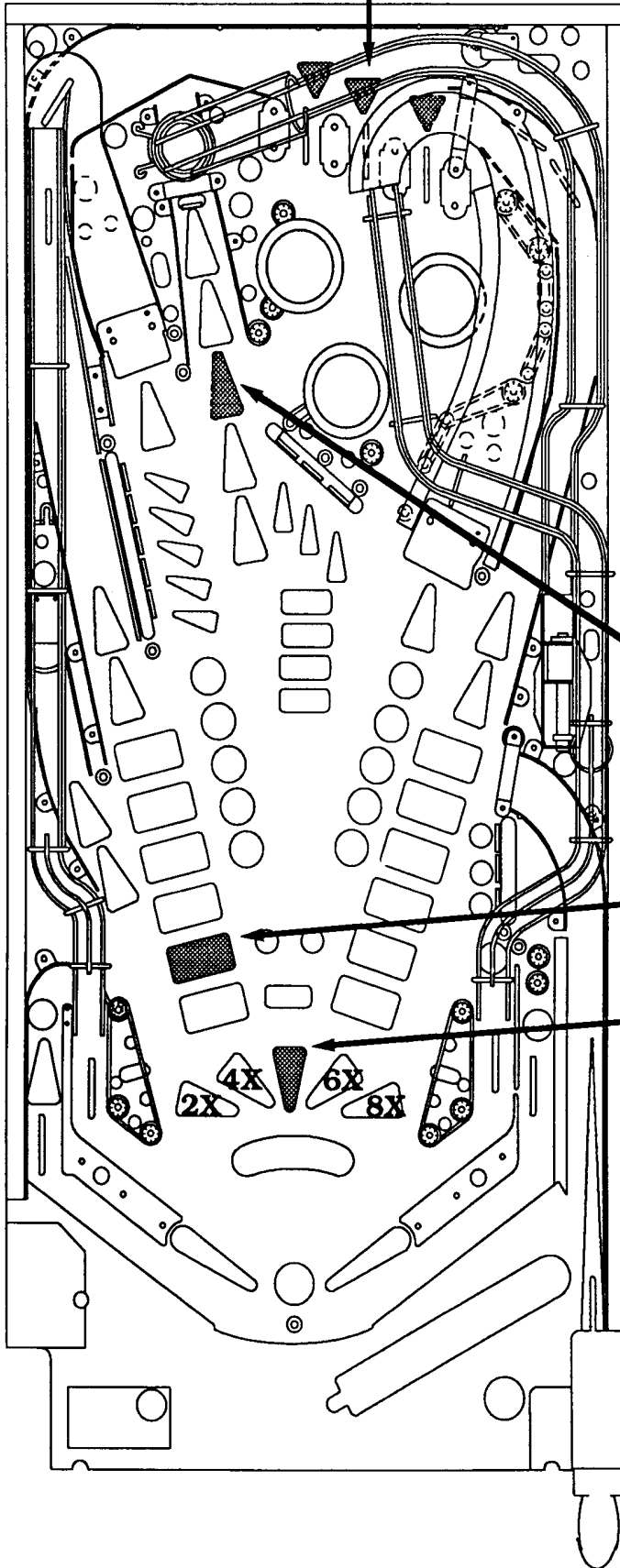

A Bonus is scored and stored in "Terminator 2's Memory". The longer a ball is played the more Bonus Points he receives. Each time the three lanes at the top are completed, the Bonus X is advanced from 2X to 8X. Consecutively completing the Top Lanes eventually loights the "Skill Extra Ball" at the Drop Target. When "Hold Bonus" is lit, all Bonus and Bonus Multipliers are carried over to the next ball. If Hold Bonus is achieved on the 3rd ball, Bonus is added Twice.

Extra Ball Lamp

Escape Route Hold Bonus Rectangle.

Hold Bonus Light

## Terminator 2 Hurry-up

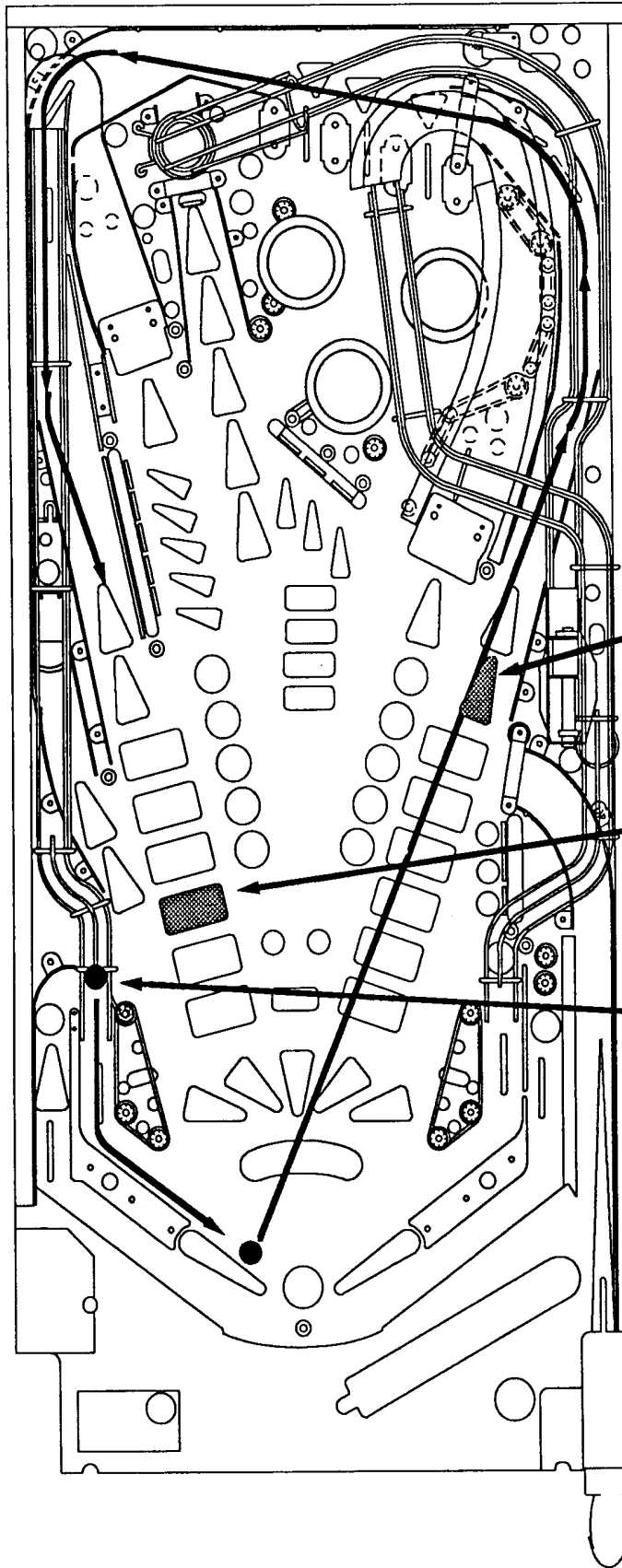

Hurry-up is a Big-Points Feature that consists of a "Points Time-Down" starting at a value of 10,000,000 and ends at 1,000,000. The sooner the player collects Hurry-Up (by shooting around Chase Loop when lit), the more points he collects. The feature can be lit by scoring 3rd level "Escape Route", or lit randomly by the Database Feature.

Hurry-up Arrow

Light Return Lanes

"Lights Hurry-up" Flipper Return Lamp.

## Terminator 2 Video Mode

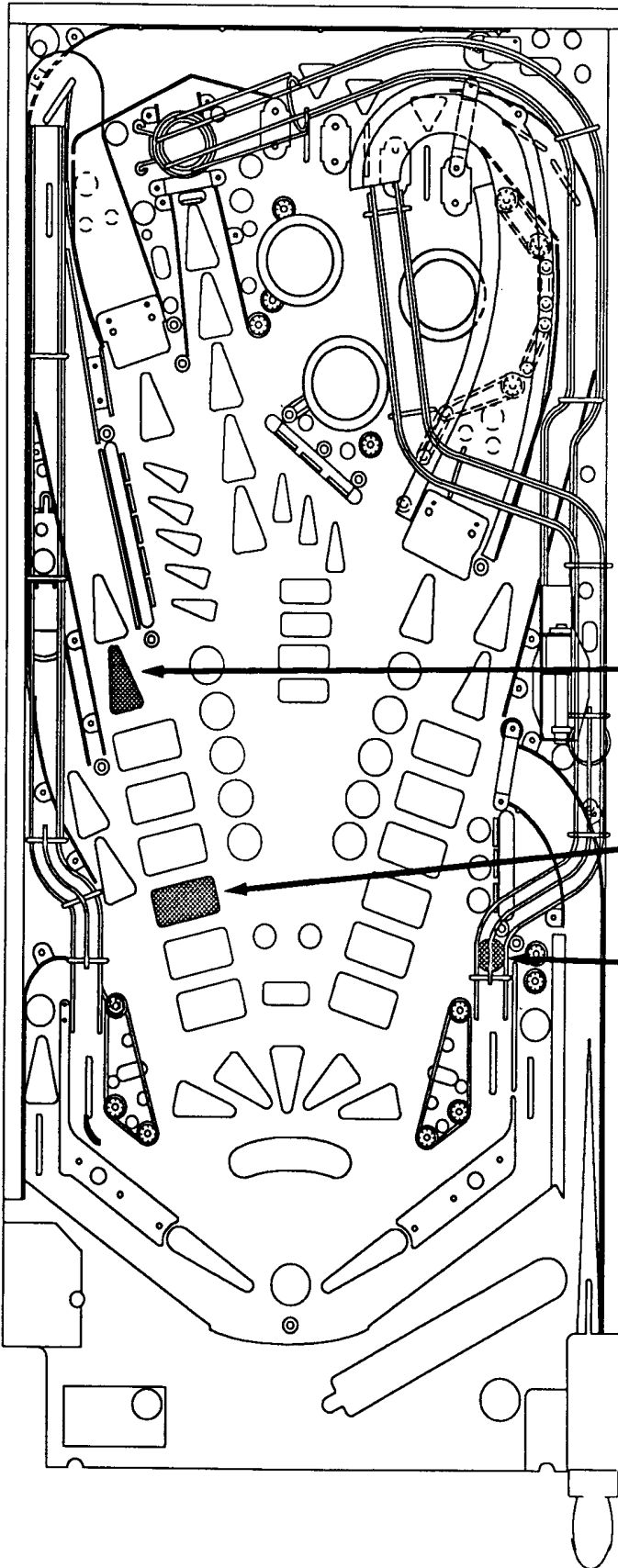

Since Terminator 2 incorporates a Dot Matrix Display with good resolution, a playable though short "Video Game" is offered to the player. It consists of Terminators which must be scored by manipulating a Cross Hair on the display. The Cross Hair can be moved left and right with the left and right Flipper Buttons. The Video Game is over if a Terminator shoots the player.

Video Mode Lamp

Light Return Lanes

Light Video Mode Lamp

# Section 1

## Game Operation & Test Information

**Terminator 2 WPC ROM Summary**  
**Pinball Game Assembly Instructions**  
**Game Play**  
**Menu System Operation**  
**Adjustments**  
**Audits**  
**Test/Diagnostic Procedures**  
**Utilities**

<b>ROM Summary</b>					
	<b>IC</b>	<b>TYPE</b>	<b>LOCATION</b>	<b>BOARD</b>	<b>PART NUMBER</b>
	Game ROM 1	27020	U6	CPU	A-5343-50013-1
Music/Speech ROM 2	27010		U14	Audio	A-5343-50013-2
Music/Speech ROM 3	27010		U15	Audio	A-5343-50013-3
Music/Speech ROM 4	27010		U18	Audio	A-5343-50013-4

### **NOTICE**

To order a replacement ROM from your authorized WILLIAMS ELECTRONICS GAMES distributor, specify: (1) part number (if available); (2) ROM label color; (3) ROM level (number) on the label; (4) which game the ROM is used in.

## Game Pinball Game Assembly Instructions

1. Open the shipping container; remove all cartons, parts, and other items, and set them aside.
2. Place the cabinet on a support and attach rear legs using leg bolts. Leg levelers and leg bolts are provided among the parts in the cash box.
3. Attach the front legs (after installing leg levelers), using leg bolts. See Figure 1 for details.

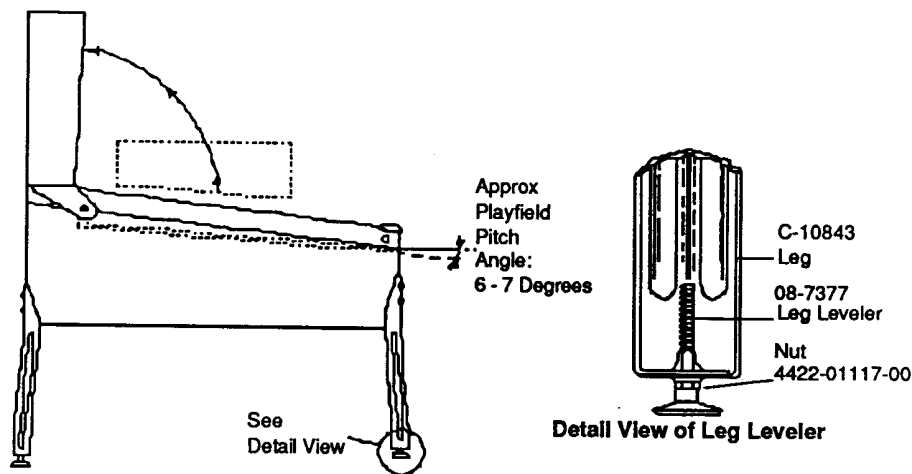

**Figure 1. Pinball Assembly, Playfield Pitch Angle, and Leg Leveler Details.**

4. Reach into the cabinet and backbox and ensure that the interconnecting cables are free to move (not kinked or pinched). Be careful to avoid damaging wires at any stage of the assembly process.

5. Raise the hinged backbox upright and latch it into position. Unlock the backbox, and remove the backglass, storing it carefully to avoid scratches. Remove the shipping block holding the Insert Board. Unlatch and open the Insert Board. Carefully lift up the Speaker Panel and lay it down on the playfield glass. (Be careful not to damage the Dot Matrix Display/Driver.) This allows access to the bolt holes used for securing the backbox upright. Install the washer-head mounting bolts through the bottom holes of the backbox into the threaded fasteners in the cabinet to secure the backbox. Close the Insert Board and latch it in position. Replace the Speaker Panel. Reinstall the backglass, and lock the backbox.

**FAILURE TO INSTALL** the backbox mounting hardware properly can cause personal injury. **NEVER TRANSPORT** a pinball game with the hinged backbox erect. *Always* lower the backbox forward onto the playfield cabinet on a layer of protective material to prevent marring or damage and possible personal injury.

6. Extend each leg leveler *slightly* below the leg bottom, so that all four foot pads are extended about the same distance. Remove the cabinet from its support and place it on the floor.

7. Unlock and open the coin door. Locate the Molding Latch Lever, and move the lever toward the left side of the game, to release the Front Molding. Lift the Front Molding off the playfield cover glass return the Latch Lever toward the right, and close the coin door. *Carefully* slide the glass downward, until it clears the grooves of the Left and Right Side Moldings. Lift the glass up and away from the game, storing it carefully to avoid breakage.

8. Place a level or an inclinometer on the playfield surface. Adjust the leg levelers for proper playfield level (side-to-side) *and* playfield pitch angle (incline) of approximately 6-7 degrees. NOTE: It is recommended that these measurements be made ON the playfield, not the cabinet nor the playfield cover glass. Tighten the nut on each leg leveler shaft to maintain this setting, as shown in Figure 1.

#### CAUTION

Playfield pitch angle adjustments can affect the operation of the plumb bob tilt, inside the cabinet. The plumb bob weight is among the parts in the cash box; the operator should install the weight and adjust this tilt mechanism for proper operation, after completion of the desired playfield pitch angle setting.

9. Attach the gun handle, (see page 1-4).

10. Move the game into the desired location; recheck the level and pitch angle of the playfield.

11. Verify that the **required number** of balls are installed in the game. **Terminator 2** uses 3 balls.

12. Install playfield mylars if desired.

**Note:** The **Terminator 2** playfield is coated with a covering called Diamond Plate™ and does not require a protective mylar. However, mylars can be purchased through your local Williams Distributor. Specify part number 03-7960-50013-1 for full playfield mylar and 03-7960-50013-2 for jet bumper area mylar.

13. Clean and reinstall the playfield cover glass, reversing the procedure of step 7. Prepare the game for player operation.

# A-14747 Gun Handle Assembly Installation

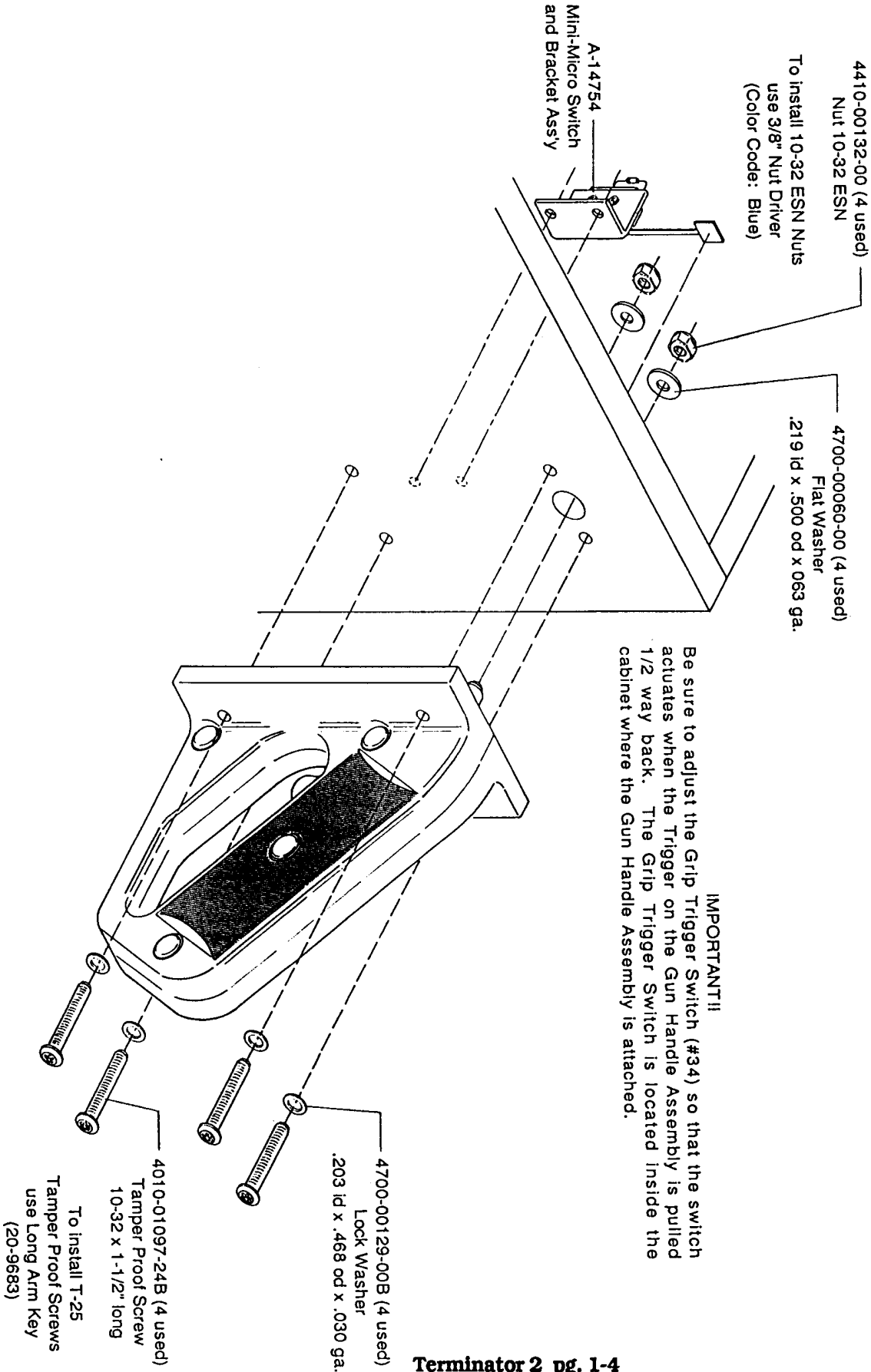



## Control Locations

### Cabinet Switches

The On-Off switch is on the bottom of the cabinet near the right front leg.

The Start Button is a pushbutton to the left of the coin door on the cabinet exterior. Press the Start button to begin a game, or during the diagnostic mode, to ask for HELP.

### Coin Door Switches

The operator controls all game adjustments, obtains bookkeeping information, and diagnoses problems, using only four pushbutton switches mounted on the inside of the coin door. The Coin Door Switches have two modes of operation Normal Function and Test Function.

#### Normal Function

The Service Credits switch puts credits on the game that are not included in the game audits.

The Volume Up switch raises the sound level of the game. Press and hold the button until the desired level is reached.

The Volume Down switch lowers the sound level of the game. Press and hold the button until the desired level is reached. See Adjustment A.1 28 to shut sound Off completely.

The Begin Test switch starts the Menu System Operation and changes the Coin Door Switches from Normal Function to Test Function.

#### Test Function

The Escape switch allows you to get out of a menu selection or return to the Attract Mode.

The Up switch allows you to cycle forward through the menu selections or adjustment choices.

The Down switch allows you to cycle backward through the menu selections or adjustment choices.

The Enter switch allows you to get into a menu selection or lock in an adjustment choice.

### Coin Door Switch Locations

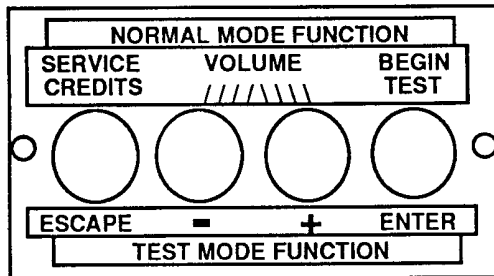

### Cabinet Switch Locations

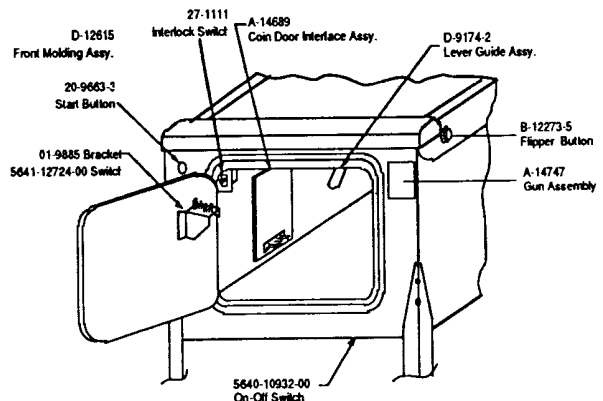

Figure 2. Pinball Game Controls Locations

## Game Operation

**After assembly and installation at its site location, this game must be plugged into a properly grounded outlet to prevent shock hazard, and to assure proper game operation. DO NOT use a 'cheater' plug to defeat the ground pin on the line cord. DO NOT cut off the ground pin.**

**POWERING UP.** With the coin door closed, plug the game in, and switch it On, using the On-Off switch. In normal operation, Testing shows in the displays as the game performs Start-up Tests. Once the Start-up Tests have been successfully completed the last score is displayed. After that, the game goes into the Attract Mode (playfield and backbox lamps flashing, sounds being heard, etc., if the operator does not change the Factory Setting).

**Note:** After the game has been on location for a period of time, the Start-up Tests may contain messages concerning game problems. The section entitled 'Problem Analysis Messages' contains more details concerning messages displayed at each game turn-on.

Open the coin door and press the Begin Test switch. The display shows the game name, the game number, and the game software revision. The message changes. The display shows the sound software revision, the revision level of the system software, and the date the game software was revised.

**Example:**

	<b>Terminator 2</b>		<b>Sound Rev. L-1</b>	
<b>50013</b>		<b>Rev. L-1</b>	<b>SY. 0.90</b>	<b>5-1-91</b>

Press the Enter button to enter the WPC Menu System (refer to the section entitled "Menu System Operation" for more information). Perform the entire Test Menu routine to verify that the game is operating satisfactorily. Successful completion of the tests in the Test Menu routine shows that the game is ready to begin earning your investment return.

**ATTRACT MODE\*.** After completing the Test Menu routine, press the Escape button three times to enter the Attract Mode. During the Attract Mode, playfield and backbox lamps blink. The player score displays exhibit a series of messages informing the player concerning:

- A. Recent highest scores\*;
- B. A "custom message"
- C. The score to achieve to obtain a Replay award\*;

These (or similar) displays reappear occasionally, accompanied by sounds and music, until a player initiates game play by inserting a coin, or when credits are available, pressing the Start button.

**CREDIT POSTING.** Insert coin(s). A sound is heard for each coin, and the player score display shows the number of credits purchased. So long as the number of maximum allowable credits\* are *NOT* exceeded by coin purchase or high score, credits are posted correctly.

**STARTING A GAME.** Press the Start button once. A startup sound plays, and the Credit amount shown in the display decreases by one. The display flashes 00 (until the first playfield switch is actuated), and shows ball 1. Additional players may enter the game by pressing the Start button once for each player, before the end of play on the first ball.

\* - operator-adjustable feature

**TILTS.** Actuating the Slam Tilt switch on the coin door inside the cabinet ends the current game and then proceeds to the Game Over Mode. With the third closure\* of the plumb bob tilt switch, the player loses the remaining play of that ball, but can complete the game.

**END OF GAME.** All earned scores and bonuses are awarded. If a player's final score exceeds the specified value, the player receives a designated award for achieving the current highest score. A random digit set\* appears in the display. Credit\* may be awarded, when the last two digits of any player's score display (1 through 4) match the random digits. Match, high score, and game over sounds are made, as appropriate.

**GAME OVER MODE.** The GAME OVER display shows in the display. Then, the high scores flash. The game proceeds to the Attract Mode.

\* - operator-adjustable feature

# Menu System Operation

## Terminator 2 Main Menu

### A. Adjustments Menu

A.1 Standard Adjustments
etc., etc.
A.2 Feature Adjustments
etc., etc.
A.3 Pricing Adjustments
etc., etc.
A.4 H.S.T.D. Adjustments
etc., etc.
A.5 Printer Adjustments

**Press Escape**

To move out of a menu selection.

**Press Enter**

To get into a menu selection.

**Press Up**

Increases sequence; (ex. A.1, A.2, A.3, A.4).

**Press Down**

Decreases sequence; (ex. A.4, A.3, A.2, A.1).

Use Up or Down to cycle through the selections in a menu.

Use Escape and Enter to move into and out of the selected menu.

### B. Bookkeeping Menu

B.1 Main Audits
etc., etc.
B.2 Earnings Audits
etc., etc.
B.3 Standard Audits
etc., etc.
B.4 Feature Audits
etc., etc.
B.5 Histograms
etc., etc.
B.6 Time-Stamped
etc., etc.

### P. Printouts Menu

P.1 Earnings Data
P.2 Main Audits
P.3 Standard Audits
P.4 Feature Audits
P.5 Score Histograms
P.6 Game Time Histograms
P.7 Time-Stamped
P.8 All Data

### T. Test Menu

T.1 Switch Edges
T.2 Switch Levels
T.3 Single Switches
T.4 Solenoid Test
T.5 Flasher Test
T.6 General Illumination
T.7 Sound and Music Test
T.8 Single Lamps
T.9 All Lamps
T.10 Lamp & Flasher Test
T.11 Display Test
T.12 Gun Test

### U. Utilities Menu

U.1 Clear Audits
U.2 Clear Coins
U.3 Reset H.S.T.D.
U.4 Set Time & Date
U.5 Custom Message
U.6 Set Game I.D.
U.7 Factory Adjustments
U.8 Factory Resets
U.9 Presets
etc., etc.
U.10 Clear Credits
U.11 Auto Burn-in

**Terminator 2** operates on a Menu System. The Main Menu allows you to choose from several main categories, which in turn lead to other menus to choose from. To enter the Menu System, open the coin door and press the Begin Test button. The displays show the Game I.D. Mode. Press the Enter button and the Main Menu appears. To cycle through the Main Menu selections press either the Up or Down button. Activate any selection by pressing the Enter button when the desired selection appears in the displays. To return to the Attract Mode while viewing the Main Menu, or to return to a previous menu selection, press the Escape button. Press the Start button for HELP at any time.

## MAIN MENU

- A. Adjustments**
- B. Bookkeeping**
- P. Printouts** (optional board required)
- T. Tests**
- U. Utilities**

The game Adjustments are the first category available from the Main Menu. Press the Enter button to activate the Adjustments Menu. Press the Up or Down button to cycle through the Adjustment Menu selections. Press the Enter button to activate the desired Adjustment Group when that group appears in the displays.

## A. ADJUSTMENTS MENU

- A.1 Standard Adjustments**
- A.2 Feature Adjustments**
- A.3 Pricing Adjustments**
- A.4 H.S.T.D Adjustments**
- A.5 Printer Adjustments** (optional board required)

Once you have entered the adjustment group desired, press the Up or Down button to cycle through the available adjustments in that group. When the desired adjustment appears press the Enter button to activate that adjustment. When an adjustment is activated, the setting value begins to flash. Use the Up or Down button to raise or lower the setting value. When the desired value is displayed press Enter to lock in the value. If you realize you have made an error, press the Escape button while "Saving Adjustment Value" is displayed. The new value is ignored and the original value is retained.

### **A.1 Standard Adjustments**

- A.1 01 Balls Per Game**  
The operator defines a "game" by specifying the number of balls to be played. The range of this setting is 1 through 10.
- A.1 02 Tilt Warnings**  
The operator specifies the number of total actuations of the plumb bob mechanism that can occur before the game is "tilted". The range of this setting is 1 through 10.
- A.1 03 Maximum Extra Balls**  
The operator chooses the number of Extra Balls that a player may accumulate. The range of this setting is 1 through 10, or "No Extra Ball" (extra ball disabled).

- A.1 04 Maximum Extra Balls/Ball in Play**  
The operator chooses the number of Extra Balls to be awarded per ball in play. The range of this setting is:
- Off - No maximum number of Extra Ball per ball in play.  
1-10 - 1 through 10 Extra Balls per ball in play.
- A.1 05 Replay System**  
The operator chooses the replay system to be used. The choices are:
- Fixed - Replay value is set by the operator and does not change during game play.  
Auto% - Replay starting value is set by the operator and changes every 50 games to comply with the percentage of replays desired.
- A.1 06 Replay Percent\***  
The operator chooses the percentage of replays the players are able to earn when Auto Replay is used. The range of this setting is 5% to 50%.
- A.1 07 Replay Start\***  
The operator chooses the replay starting value when Auto% Replay is used. The range of this setting is 15, 000, 000 to 250, 000, 000.
- A.1 08 Replay Levels\***  
The operator chooses the number of replay levels used by the Auto% Replay mode. The range of this setting is 1 through 4. When the operator chooses two replay levels, the second replay level is automatically adjusted to twice starting replay level value. When three or four replay levels are chosen, their values are automatically adjusted to three or four times the starting replay level value.
- A.1 09 Replay Level 1\*\***  
The operator chooses the value to be used for the first Fixed Replay. The range of this setting is 00 to 250, 000, 000.
- A.1 10 Replay Level 2\*\***  
The operator chooses the value to be used for the second Fixed Replay. The range of this setting is 00 to 250, 000, 000.
- A.1 11 Replay Level 3\*\***  
The operator chooses the value to be used for the third Fixed Replay. The range of this setting is 00 to 250, 000, 000.
- A.1 12 Replay Level 4\*\***  
The operator chooses the value to be used for the fourth Fixed Replay. The range of this setting is 00 to 250, 000, 000.
- A.1 13 Replay Boost**  
The operator chooses if the replay score can be temporarily boosted by the selected amount EACH time the player reaches or exceeds the replay score. This temporary boost is cancelled when Credits=0, when the player inserts another coin, or when Begin Test is pressed. The range of this setting is Off, 1, 000, 000 to 50, 000, 000.

\*For Auto % Replay. \*\* For Fixed Replay

- A.1 14 Replay Award**  
 For either Auto% Replay or Fixed Replay the operator can choose the form of the award automatically provided when the player exceeds any replay level. The choices are:
- Credit - Reaching each Replay level awards credit.
  - Ticket - Reaching each Replay level awards a ticket.
  - Ball - Reaching each Replay level awards an Extra Ball.
  - Audit - Reaching each Replay level awards nothing to the player; it does increase the entry value of the Audit Item(s) maintaining a tally of these awards.
- A.1 15 Special Award**  
 The operator can choose the award automatically provided when the player scores a special. The choices are:
- Credit - Scoring a Special awards a Credit.
  - Ticket - Scoring a Special awards a Ticket.
  - Ball - Scoring a Special awards an Extra Ball.
  - Points - Scoring a Special awards 1 Million points.
- A.1 16 Match Award**  
 The operator can choose the award automatically provided when the players wins a match. The choices are:
- Credit - Winning a Match awards a Credit.
  - Ticket - Winning a Match awards a Ticket.
- A.1 17 Extra Ball Ticket**  
 The operator can choose whether a Ticket is awarded when the player earns an Extra Ball. The choices are:
- Yes - The player is awarded a Ticket in addition to an Extra Ball.
  - No - The player is not awarded a Ticket.
- A.1 18 Maximum Ticket/Player**  
 The operator can choose the amount of Tickets each player can earn. The range of this setting is 00 to 100.
- A.1 19 Match Feature**  
 The operator can choose the desired percentage for the Match Feature occurring at the end of the game. The range of this setting is:
- Off - Match Feature is not available.
  - 1 -50% - 1% is 'hard'; 50% is 'extremely easy'. During the Match Feature the game selects a random two-digit number at the end of the game and compares each players score for an identical two digits in the rightmost two positions. A matching of these two digit results in ward of a Credit or a Ticket.
- A.1 20 Custom Message**  
 The operator chooses if a message is displayed during the Attract Mode. The choices are:
- Yes - A message is displayed
  - No - A message is not displayed.

- A.1 21 Language**  
The operator chooses what language the game uses. The choices are, English, French, or German.
- A.1 22 Clock Style**  
The operator chooses what style of clock the game uses. The choices are A.M./P.M. or 24 Hours.
- A.1 23 Date Style**  
The operator chooses what style of date the game uses. The choices are Month/Date/Year, or Date/Month/Year.
- A.1 24 Show Date and Time**  
The operator chooses whether the date and time show in the Attract Mode. The choices are:
- Yes - Show the date, time in status report or in the Attract Mode.  
No - Do Not show date, time in status report or in the Attract Mode.
- A.1 25 Allow Dim Illumination**  
The operator chooses whether to allow the game program to dim the General Illumination for special effects and during the Attract Mode. The choices are:
- Yes - Dim the General Illumination during the Attract Mode.  
No - Do Not dim the General Illumination.
- A.1 26 Tournament Play**  
The operator chooses whether to equalize Jackpots during multi-player games, (do not carry over to next player). The choices are:
- Yes - Keep Jackpots equal.  
No - Do Not Keep Jackpots equal.
- A.1 27 Euro. Scr. Format**  
The operator chooses whether to have commas or dots between digits when numbers are displayed. The choices are:
- Yes - Dots instead of commas, (example- 1.000.000).  
No - Commas instead of dots, (example- 1, 000, 000).
- A.1 28 Minimum Volume Control**  
The operator chooses whether the volume can be turned Off. The choices are:
- Yes - Volume can be turned Off.  
No - Volume can be turned Down but not Off.
- A.1 29 G.I. Power Saver**  
This adjustment allows the General Illumination and Controlled lamps to be dimmed following a time interval after a game is played. A.1 30 (Power Saver Level) determines how dim the lamps get. Using this feature substantially increases the life of the lamps. The range of this setting is Off, 2 through 60 minutes.
- A.1 30 Power Saver Level**  
When A.1 29 (G.I. Power Saver) is set to On, this adjustment controls the intensity of the G.I. and Controlled lamps once the game has been idle for a specified time period. The range of this setting is 4 through 7.



Press the Escape button to return to the Adjustments Menu. Press the Up button to advance to the next desired Adjustments Group, (or press the Down button to return to a previous group). Press the Enter button to activate. Use the Up or Down button to cycle through the available adjustments.

## **A.2 Feature Adjustments**

### **A.2 01 Special Percent**

The operator chooses the percent of games that Special is awarded. The range of this setting is Off, 1% through 10%.

### **A.2 02 Extra Ball Percent**

The operator chooses the percent of games that award an Extra Ball. The range of this setting is Off, 1% through 35%.

### **A.2 03 Extra Ball Memory**

The operator chooses whether the Extra Ball Light is carried over from ball to ball, or reset at ball start. The choices are:

- On - The Extra Ball Light is carried Over from ball to ball.
- Off - The Extra Ball Light is reset at ball start.

### **A.2 04 Consolation Ball**

The operator chooses if a player with a low score has a chance to obtain a Consolation Ball. The choices are:

- On - The player has a chance to obtain a Consolation Ball.
- Off - The player cannot obtain a Consolation Ball

### **A.2 05 Drop Target Count**

The operator chooses the number of successful Gun hits that must occur before the Drop Target starts to time out. The range of this setting is 0 through 3.

### **A.2 06 Three Bank Count**

The operator chooses the number of times the 3-bank Drop Target must be completed before the middle three bank target starts to time out. The range of this setting is 0 through 4.

### **A.2 07 Kickback Setting**

The operator chooses when the Kickback is On. The choices are:

- Extra Easy - Always On
- Easy - On at Ball Start
- Medium - On at Game Start with Memory
- Hard - Off at Game Start with Memory
- Extra Hard - Off at Ball Start

### **A.2 08 Skill Shot Timer**

The operator chooses the time before the targets lamps move. The choices are:

- Extra Easy - 1-1/4 sec
- Easy - 1 sec
- Medium - 3/4 sec
- Hard - 1/2 sec
- Extra Hard - 1/4 sec

- A.2 09 Drop Target Timer**  
The operator chooses the time allowed before the drop target comes back up. The range of this setting is 5 seconds to 99 seconds.
- A.2 10 Three Bank Timer**  
The operator chooses the time allowed for the Middle Three Bank Target. The range of this setting is 5 seconds to 99 seconds.
- A.2 11 Hurry Up Timer**  
The operator chooses the time allowed for the Hurry Up feature. The range of this setting is 7 seconds to 99 seconds.
- A.2 12 Payback Timer**  
The operator chooses the time allowed for the Payback Time Feature. The range of this setting is 10 seconds to 99 seconds.
- A.2 13 Jackpot Timer**  
The operator chooses the time allowed to complete the Jackpot. The range of this setting is 8 seconds to 99 seconds.
- A.2 14 Million Plus**  
The operator chooses whether the million points awarded for combination Chase Loop shots is incremented or not. The choices are:
- On - Increment Millions for combination Chase Loop Shots.
  - Off - Only award 1 Million for each combination Chase Loop Shot.
- A.2 15 Timed Plunger**  
The operator chooses whether the plunger kicks automatically for the player. The choices are:
- On - After 1-1/2 minutes of inactive play the plunger kicks automatically.
  - Off - The plunger does not kick automatically.
- A.2 16 Attract Sounds**  
The operator chooses whether the game produces sounds during the Attract Mode. The choices are:
- On - The game does produce sounds during the Attract Mode.
  - Off - The game does Not produce sound during the Attract Mode.
- A.2 17 Drop Target Autofire**  
The operator chooses whether Autofire comes On when the Drop Target is knocked down. The choices are:
- On - Autofire turn On for one second when the target drops.
  - Off - Autofire does not turn On.
- A.2 18 Fan Club Attract Mode**  
The operator chooses whether Fan Club information appears in the Attract Mode. The choices are:
- On - Fan Club information is displayed.
  - Off - Fan Club information is not displayed.

**A.2 19 Flipper Trigger**

The operator chooses whether pressing the Flippers Buttons, as well as the Gun Handle Trigger, can shoot the ball. The choices are:

- On - Pressing the Flipper Buttons shoots the ball.
- Off - Pressing the Flipper Buttons does not shoot the ball.

Press the Up button to advance to the next desired Adjustment Group, (or press the Down button to return to a previous Adjustment Group). Press the Enter button to activate that group. Press the Up or Down button to cycle through the available adjustments in that group.

**A.3 Pricing Adjustments**

**A.3 01 Game Pricing (if set to custom, then 02 to 09 are available)**

The operator chooses the cost for a game from a selection of Standard pricing or by installing Custom pricing.

**A.3 02 Left Coin Units**

The operator can specify the number of coin units purchased by a coin passing through the left coin chute.

**A.3 03 Center Coin Units**

The operator can specify the number of coin units purchased by a coin passing through the center coin chute.

**A.3 04 Right Coin Units**

The operator can specify the number of coin units purchased by a coin passing through the right coin chute.

**A.3 05 4th Slot Units**

The operator can specify the number of coin units purchased by a coin passing through the fourth coin chute.

**A.3 06 Units/Credits**

The operator defines the number of coin units required to obtain 1 credit. A coin unit counter in the game program totals the number of coin units purchased through all coin chutes prior to each game. If the total number of these coin units exceeds or matches the Unit per Credit value by a multiple (or more, coin units) of the specified Units per Credit value the Credits display shows the proper number of credits. The coin unit counter retains any remaining coin units, until the start of Ball 2; then the coin unit counter is cleared (its contents are zeroed).

**A.3 07 Units/Bonus**

The operator can specify that additional credits are to be indicated in the credits display, when a certain number of coin units are accumulated.

**A.3 08 Bonus Credits**

The operator specifies the number of credits that are awarded when the Units/Bonus level is achieved.

**A.3 09 Minimum Units**

The operator can specify that No credits are to be posted (indicated in the credit display), until the credits unit counter reaches a particular value, by setting this value to 02 (or more).

- A.3 10 Coin Door Type (if set to custom, then 11 to 15 are available)**  
This adjustment is used to pre-set adjustments 11 to 15 based on standard coin doors (U.S.A., German, etc.).
- A.3 11 Collection Text**  
The operator chooses what coin system is used to display the Earning Audits.
- A.3 12 Left Slot Value**  
The operator can specify the monetary value of the left coin chute.
- A.3 13 Center Slot Value**  
The operator can specify the monetary value of the center coin chute.
- A.3 14 Right Slot Value**  
The operator can specify the monetary value of the right coin chute.
- A.3 15 4th Slot Value**  
The operator can specify the monetary value of the 4th coin chute.
- A.3 16 Maximum Credits**  
The operator can specify the maximum number of credits the game can accumulate, either through game play awards or coin purchases. The range of this setting is 5 through 10. Reaching the specified setting prevents the award of any credits.
- A.3 17 Free Play**  
The operator can specify whether a player can operate the game without a coin (free play) or with a coin. The choices are:
- No - A coin is necessary for game play.  
Yes - Game play is free; no coin required.
- A.3 18 Hide Coin Audits**  
The operator chooses whether or not to show the coin audits. The choices are:
- Yes - The coin audits are not displayed.  
No - The coin audits are displayed.  
Hide Names - The coin audit value is shown but not the audit name.
- A.3 19 1 Coin Buy-in**  
If the game pricing is set to 1 for 50¢/2 for \$1.00 the operator chooses whether the player is allowed to 'buy-in' a subsequent game for 1 coin. The number of games that may be purchased at this cost is determined by the number of players in the previous game; that is, if the previous game had three players, 3 Credits can be purchased at the rate of 1 coin per credit. The choices are:
- Yes - The player has 10 seconds to buy-in at 1 coin per game.  
No - The buy-in feature is disabled.

**Pricing Table**

Country	Coin Chute				Games/Coin	Display	Pricing Adjustments A.3							
	Left	Center	Right	4th Chute			02	03	04	05	06	07	08	09
USA	25¢	\$1.00*	25¢	-	1/25¢, 4/\$1 <sup>2</sup>	U.S.A. 4/\$1.00								
					1/50¢, 2/75¢, 3/\$1 <sup>1,2</sup>	50-75-1.00								
Canada	25¢	-	\$1.00	-	1/50¢, 2/75¢, 3/\$1 <sup>2</sup>	CANADA 1								
					1/50¢, 2/\$1 <sup>2</sup>	CANADA 2								
Austria	5 Sch	10 Sch	10 Sch	-	1/2x5 Sch, 3/2x10 Sch <sup>2</sup>	AUSTRIA								
	5 Sch	-	10 Sch	-	2/5 Sch, 5/10 Schilling	CUSTOM	02	00	05	00	01	00	01	00
Australia	20¢	\$1	\$1	\$2	1/\$1, 3/\$2 <sup>2</sup>	AUSTRALIA								
United Kingdom	1L	50 P	0	20 P	1/2x10 P, 3/50 P, 7/1£ <sup>2</sup>	U. KINGDOM								
Switzerland	1 Fr	2 Fr	5 Fr	-	1/1 Fr, 3/2 Fr, 7/5 Franc <sup>2</sup>	SWISS								
Belgium	5Fr	20 Fr	50 Fr	-	1/4 x 5F, 1/20 F, 3/50 Franc <sup>2</sup>	BELGIUM								
West Germany	1 DM	2 DM	5 DM	-	1/1 DM, 2/2 DM, 7/5 DMark <sup>2</sup>	GER. 7/6 DM								
					1/1 DM, 2/2 DM, 6/5 DM <sup>1,2</sup>	GER. 6/5 DM								
					1/1 DM, 3/2 DM, 9/5 DM	CUSTOM	09	18	45	00	05	00	01	00
					1/2x1 DM, 1/2 DM, 3/5 DM	CUSTOM	03	06	15	00	05	00	01	00
Netherlands	1 HFI	2.5 HFI	2.5 HFI	-	2/1 DM, 5/2 DM, 14/5 DM	CUSTOM	13	26	65	00	05	65	01	00
	25¢	-	1G	-	1/1 HFI, 3/2.5 Holland Florin <sup>2</sup>	NETHERLAND								
	1G	-	1G	-	1/25¢, 5/1 Guilder	CUSTOM	01	00	05	00	01	00	01	00
					1/1 Guilder <sup>2</sup>	HOLLAND								
Sweden	5 Kr	5 Kr	5 Kr	-	1/5 Kröna <sup>2</sup>	SWEDEN								
France	1 Fr	5 Fr	10 Fr	-	1/3x1 F, 2/5 F, 5/10 Franc <sup>2,3</sup>	TARIF 1								
	1 Fr	5 Fr	10 Fr	-	1/2x1 F, 3/5 F, 7/10 Franc <sup>2,3</sup>	TARIF 2								
	1 Fr	5 Fr	10 Fr	-	1/5 F, 3/10 F, 7/2x10 Franc <sup>2,3</sup>	TARIF 3								
	1 Fr	5 Fr	10 Fr	-	2/5 F, 4/10 F, 9/2x10 Franc <sup>1, 2,3</sup>	TARIF 4								
	1 Fr	5 Fr	10 Fr	-	2/5 F, 5/10 F, 11/2x10 Franc <sup>2,3</sup>	TARIF 5								
	1 Fr	5 Fr	10 Fr	-	1/5 F, 3/10 Franc <sup>2,3</sup>	TARIF 6								
Italy	500L	500L	500L	-	1/500 Lire <sup>2</sup>	ITALY								
Spain	25 P	-	100 P	-	1/25 P, 5/100 Peseta <sup>2</sup>	SPAIN								
	25 P	-	100 P	-	1/25 P, 4/100 Peseta	CUSTOM	01	00	04	00	01	00	01	00
	25 P	-	100 P	-	1/2x25 P, 2/100 Peseta	CUSTOM	01	00	04	00	02	00	01	00
	25 P	-	100 P	-	1/2x25 P, 3/100 Peseta	CUSTOM	03	00	12	00	04	00	01	06
Japan	100 ¥	-	100 ¥	-	1/100 Yen <sup>2</sup>	JAPAN								
Antilles, Nthrlnd	25¢	-	1G	-	1/25¢, 4/1 Guilder <sup>2</sup>	ANTILLES								
Chile	Token	-	Token	-	1/1 Token <sup>2</sup>	CHILE								
Denmark	1 Kr	5 Kr	10 Kr	-	1/2x1 Kr, 3/5 Kr, 7/10 Krone <sup>2</sup>	DENMARK								
Finland	1 Mka	-	5 Mka	-	1/2x1 Mka, 3/5 Markka <sup>2</sup>	FINLAND								
New Zealand	20¢	-	20¢	-	1/3x20¢ <sup>2</sup>	N. ZEALAND								
Norway	5Kr	-	10 Kr	-	1/5 Kr, 2/10 Kr, 5/20 Krone <sup>2</sup>	NORWAY								
Argentina	10¢	10¢	10¢	-	1/1 Token <sup>2</sup>	ARGENTINA								
Greece	10 D	20 D	50 D	-	1/2x10D, 1/20D, 3/50 Drachma <sup>2</sup>	GREECE								
Hungary	10 F	-	20 F	-	1/1x20F, 1/2x10F, 3/2x20 Forint	HUNGARY								

**Notes:** 1. Factory Default 2. Standard Setting - Change by pressing Enter button. 3. Other functions are also affected.

\* Only if Dollar Bill Acceptor and Center Coin Chute is Available.

Press the Escape button to return to the Adjustment Menu. Press the Up button to advance to the next desired Adjustment Group, (or press the Down button to return to a previous Adjustment Group). Press the Enter button to activate that group. Press the Up or Down button to cycle through the available adjustments in that group.

## **A.4 H.S.T.D. Adjustments**

### **A.4 01 Highest Scores**

The operator specifies whether the game is to maintain a record of the four highest scores achieved to date. The choices are:

- Off - No high scores are recorded, or displayed.
- On - The four highest scores are stored in memory and displayed in the Attract Mode.

### **A.4 02 H.S.T.D. Award**

The operator chooses the award given for achieving the High Score To Date, or the Champion H.S.T.D.. The choices are a Credit or a Ticket.

### **A.4 03 Champion H.S.T.D.**

The operator chooses whether the "Highest" High Score is displayed in the Attract Mode. This score is not cleared when "High Score Reset Every" occurs. The choices are:

- On - The "Highest" High Score is retained in memory and displayed.
- Off - The "Highest" High Score is not retained.

### **A.4 04 Champion Credits**

The operator chooses the number of credits or tickets awarded for a Grand Champion Score. The range of this setting is 00 through 10.

### **A.4 05 H.S.T.D. 1 Credits**

The operator selects the number of credits or tickets to be awarded whenever a player exceeds the previous Highest Score. The range of this setting is 00 to 10.

### **A.4 06 H.S.T.D. 2 Credits**

The operator selects the number of credits or tickets to be awarded whenever a player exceeds the second highest score. The range of this setting is 00 to 10.

### **A.4 07 H.S.T.D. 3 Credits**

The operator selects the number of credits or tickets to be awarded whenever a player exceeds the third highest score. The range of this setting is 00 to 10.

### **A.4 08 H.S.T.D. 4 Credits**

The operator selects the number of credits or tickets to be awarded whenever a player exceeds the fourth highest score. The range of this setting is 00 to 10.

### **A.4 09 High Score Reset Every**

The operator can specify that the game will provide an automatic reset of the displayed "Highest scores", and the number of games to be played before the reset occurs. The values provided upon reset are those selected by the operator in the Back-up High Scores. The range of this setting is OFF (disabled) and 250 to 20, 000.

### **A.4 10 Backup Champion**

The operator sets the Back-up Grand Champion Score. The range of this setting is 00 through 999, 000, 000.

- A.4 11 Backup H.S.T.D. 1**  
The operator can set the Back-up High Score value. The game automatically restores this value when the High Score Reset Every value is reached. The range of this setting is 00 to 999, 000, 000.
- A.4 12 Backup H.S.T.D. 2**  
The operator can set the second Back-up High Score value. The game automatically restores this value when the High Score Reset Every value is reached. The range of this setting is 00 to 999, 000, 000.
- A.4 13 Backup H.S.T.D. 3**  
The operator can set the third Back-up High Score value. The game automatically restores this value when the High Score Reset Every value is reached. The range of this setting is 00 to 999, 000, 000.
- A.4 14 Backup H.S.T.D. 4**  
The operator can set the fourth Back-up High Score value. The game automatically restores this value when the High Score Reset Every value is reached. The range of this setting is 00 to 999, 000, 000.

Press the Up button to advance to the next desired Adjustment Group, (or press the Down button to return to a previous Adjustment Group). Press the Enter button to activate that group. Press the Up or Down button to cycle through the available adjustments in that group.

#### **A.5 Printer Adjustments** (optional board required)

- A.5 01 Column Width**  
Choose the column width to be printed. The range of this setting is 22 to 80.
- A.5 02 Lines Per Page**  
Choose the amount of lines per page. The range of this setting is 20 to 80.
- A.5 03 Pause Every Page**  
Choose whether the printer pauses at the end of a page. The choices are:  
  - Yes - The printer does pause.
  - No - The printer doesn't pause.
- A.5 04 Printer Type**  
Select the type of printer. The choices are: Parallel, Serial or ADP.
- A.5 05 Serial Baud Rate**  
Select which baud rate to use for serial or ADP communications (bit rate). The choices are 300, 600, 1200, 2400, 4800, or 9600.
- A.5 06 Serial D.T.R. (Data Terminal Ready)**  
When a serial printer is used, this line may be connected to a printer output line signaling that the printer is busy.  
  - Normal - Normal D.T.R. signal goes low to indicate the printer is not ready.
  - Inverted - Inverted D.T.R. (busy) signal goes high to indicate the printer is not ready.
  - Ignore - D.T.R. signal is ignored.

Press the Escape button to return to the Adjustments Menu. Then, either press the Up or Down button to return to a previous Adjustment Menu Group, or press the Escape button again to return to the Main Menu. Once in the Main Menu, either press the Up button to advance to the next menu selection, the Bookkeeping Menu, or press the Down button to return to a previous Main Menu selection.

Press the Enter button to activate the Bookkeeping Menu, once the menu name is shown under the Main Menu. Then, use the Up or Down button to cycle through the Bookkeeping Menu selections. Press the Enter button to activate the desired Bookkeeping Group when that group appears in the displays.

## **B. BOOKKEEPING MENU**

- B.1 Main Audits**
- B.2 Earning Audits**
- B.3 Standard Audits**
- B.4 Feature Audits**
- B.5 Histograms**
- B.6 Time-Stamps**

Once you have entered the desired Bookkeeping Group, press the Up or Down button to cycle through the available audits in that group. Audits cannot be set, they can only be cleared by using U1 and U2 from the Utilities Menu.

### **One-Button Audit System**

Information from the Bookkeeping Menu is obtainable directly from the Attract Mode. Continually pressing the Enter button, while in the Attract Mode, will cycle through all of the game audits.

**B.1 Main Audits** These audits (which also appear in other groups) are the most important, and are grouped here for easier access.

B.1	01	Total Earnings	00
B.1	02	Recent Earnings	00
B.1	03	Free Play Percent	00
B.1	04	Average Ball Time	00
B.1	05	Average Game Time	00
B.1	06	Total Plays	00
B.1	07	Replay Awards	00
B.1	08	Percent Replays	00
B.1	09	Extra Balls	00
B.1	10	Percent Extra Ball	00

Press the Escape button to return to the Bookkeeping Menu. Press the Up button to advance to the next desired Bookkeeping Group, (or press the Down button to return to a previous group). Press the Enter button to activate that group. Press the Up or Down button to cycle through the available audits in that group.



## B.2 Earning Audits

B.2	01	Recent Earnings	00
B.2	02	Recent Left Slot	00
B.2	03	Recent Center Slot	00
B.2	04	Recent Right Slot	00
B.2	05	Recent 4th Slot	00
B.2	06	Recent Paid Credits	00
B.2	07	Recent Service Credits	00
B.2	08	Total Earnings*	00
B.2	09	Total Left Slot*	00
B.2	10	Total Center Slot*	00
B.2	11	Total Right Slot*	00
B.2	12	Total 4th Slot*	00
B.2	13	Total Paid Credits*	00
B.2	14	Total Service Credits*	00

\* Note: These Audits are NOT Resettable. They are a record of the earnings of the game since the "CLOCK 1ST SET" Time -Stamp.

Press the Escape button to return to the Bookkeeping Menu. Press the Up button to advance to the next desired Bookkeeping Group, (or the Down button to return to a previous group). Press the Enter button to activate. Press the Up or Down button to cycle through the available audits.

## B.3 Standard Audits

B.3	01	Games Started	00
B.3	02	Total Plays*	00
B.3	03	Total Free Play	00
B.3	04	Free Play Percent	00
B.3	05	Replay Awards	00
B.3	06	Percent Replays	00
B.3	07	Special Awards	00
B.3	08	Percent Special	00
B.3	09	Match Awards	00
B.3	10	Percent Match	00
B.3	11	H.S.T.D. Credits	00
B.3	12	Percent H.S.T.D	00
B.3	13	Extra Ball	00
B.3	14	Percent Extra Ball	00
B.3	15	Tickets Awarded	00
B.3	16	Percent Tickets	00
B.3	17	Left Drains	00
B.3	18	Right Drains	00
B.3	19	Average Ball Time	00
B.3	20	Average Game Time	00
B.3	21	Minutes of Play	00
B.3	22	Minutes On	00
B.3	23	Balls Played	00
B.3	24	Tilts	00
B.3	25	Replay 1 Awards	00
B.3	26	Replay 2 Awards	00
B.3	27	Replay 3 Awards	00
B.3	28	Replay 4 Awards	00
B.3	29	1 Player Games	00
B.3	30	2 Player Games	00
B.3	31	3 Player Games	00
B.3	32	4 Player Games	00
B.3	33	H.S.T.D. Reset Count	00
B.3	34	Burn-in Cycles	00
B.3	35	1st Replay Level	7,200,000

\* As a new WPC feature, the "Total Plays" counter only counts completed games. A game is considered completed when the final ball begins. Audit information from an incomplete game is ignored. Therefore operation for test and service do not affect the Audits.

Press the Escape button to return to the Bookkeeping Menu. Press the Up button to advance to the next desired Bookkeeping Group, (or press the Down button to return to a previous group). Press the Enter button to activate that group. Press the Up or Down button to cycle through the available audits in that group.

#### **B.4 Feature Audits**

B.4	01	Skill Shot	%00
B.4	02	Security Levels	%00
B.4	03	Payback Times	%00
B.4	04	Payback Awards	%00
B.4	05	Databases	%00
B.4	06	Chase Loop 5 Mil.	%00
B.4	07	Chase Loop Combo	%00
B.4	08	Chase Loops	%00
B.4	09	Ramp Combos	%00
B.4	10	Multipliers	%00
B.4	11	Multipliers Maxed	%00
B.4	12	Autofire Savers	%00
B.4	13	Total Autofires	%00
B.4	14	1X Jackpots	%00
B.4	15	2X Jackpots	%00
B.4	16	3X Jackpots	%00
B.4	17	Super Jackpots	%00
B.4	18	10 Millions	%00
B.4	19	Bonus Held	%00
B.4	20	Hurry Up Lit	%00
B.4	21	Hurry Ups Started	%00
B.4	22	Hurry Ups Awards	%00
B.4	23	Advance Escape Route	%00
B.4	24	Escape Routes	%00
B.4	25	Kickback Relit	%00
B.4	26	Kickbacks	%00
B.4	27	Multi-balls	%00
B.4	28	Popper Shots	%00
B.4	29	Gun Loaded	%00
B.4	30	Gun Hits	%00
B.4	31	Lit Consol. Ball	%00
B.4	32	Consolation Ball	%00
B.4	33	Video Mode Lit	%00
B.4	34	Video Mode Started	%00
B.4	35	Video Mode End	%00
B.4	36	Database Extra Ball	%00
B.4	37	Database Hurry-up	%00
B.4	38	Database Video Mode	%00

Press the Escape button to return to the Bookkeeping Menu. Press the Up button to the advance to the next desired Bookkeeping Group, (or press the Down button to return to a previous Bookkeeping Group). Press the Enter button to activate that group. Press the Up or Down button to cycle through the available audits in that group.

## B.5 Histograms

B.5	01	0.0-1.9 Million Scores	00%	00
B.5	02	2.0-4.9 Million Scores	00%	00
B.5	03	5.0-9.9 Million Scores	00%	00
B.5	04	10-19 Million Scores	00%	00
B.5	05	20-29 Million Scores	00%	00
B.5	06	30-39 Million Scores	00%	00
B.5	07	40-49 Million Scores	00%	00
B.5	08	50-69 Million Scores	00%	00
B.5	09	70-99 Million Scores	00%	00
B.5	10	100-149 Million Scores	00%	00
B.5	11	150-199 Million Scores	00%	00
B.5	12	200-299 Million Scores	00%	00
B.5	13	Over 300 Million	00%	00
B.5	14	Game Time 0.0-1.0 Mins	00%	00
B.5	15	Game Time 1.0-1.5 Mins	00%	00
B.5	16	Game Time 1.5-2.0 Mins	00%	00
B.5	17	Game Time 2.0-2.5 Mins	00%	00
B.5	18	Game Time 2.5-3.0 Mins	00%	00
B.5	19	Game Time 3.0-3.5 Mins	00%	00
B.5	20	Game Time 3.5-4.0 Mins	00%	00
B.5	21	Game Time 4-5 Mins	00%	00
B.5	22	Game Time 5-6 Mins	00%	00
B.5	23	Game Time 6-8 Mins	00%	00
B.5	24	Game Time 8-10 Mins	00%	00
B.5	25	Game Time 10-15 Mins	00%	00
B.5	26	Game Time Over 15 Mins	00%	00

Press the Escape button to return to the Bookkeeping Menu. Press the Up button to the advance to the next desired Bookkeeping Group, (or press the Down button to return to a previous Bookkeeping Group). Press the Enter button to activate that group. Press the Up or Down button to cycle through the available audits in that group.

## B.6 Time-Stamps

The Time-Stamps Menu allows you to view dates and times that are important to game software.

B.6	01	Current Time
B.6	02	Clock 1st Set
B.6	03	Clock Last Set
B.6	04	Audits Cleared
B.6	05	Coins Cleared
B.6	06	Factory Setting
B.6	07	Last Game Start
B.6	08	Last Replay
B.6	09	Last H.S.T.D. Reset
B.6	10	Champion Reset
B.6	11	Last Printout
B.6	12	Last Service Credit

Press the Escape button to return to the Bookkeeping Menu. Then, either press the Up or Down button to return to a previous Bookkeeping Menu Group, or press the Escape button again to return to the Main Menu. Once in the Main Menu either press the Up button to advance to the next menu selection, the Printouts Menu, or press the Down button to return to a previous Main Menu selection.

Press the Enter button to activate the Printouts Menu, once the menu name is shown under the Main Menu. Then, use the Up or Down button to cycle through the Printouts Menu selections. Press the Enter button to activate the desired Printouts Group when that group appears in the displays.

## **P. PRINTOUTS MENU**

(optional board, required)

- P.1 Earnings Data**
- P.2 Main Audits**
- P.3 Standard Audits**
- P.4 Feature Audits**
- P.5 Score Histograms**
- P.6 Time Histograms**
- P.7 Time-Stamps**
- P.8 All Data**

The Printouts Menu is a combination of the other menus. This menu allows you to access and print information in the available menu selections.

If no Printer is attached the the message "Waiting for Printer" appears in the displays.

**Note:** Set the print specification from the Adjustment Menu, A.5 Printer Adjustments.

Press the Escape button to return to the Printouts Menu. Then, either press the Up or Down button to return to a previous Printouts Menu Group, or press the Escape button again to return to the Main Menu. Once in the Main Menu press the Up button to advance to the next menu selection, the Test Menu, or press the Down button to return to a previous Main Menu selection.

Press the Enter button to activate the Test Menu, once the menu name is shown under the Main Menu. Then, use the Up or Down button to cycle through the Test Menu selections. Press the Enter button to activate the desired test when that test appears in the displays.

## **T. TEST MENU**

- T.1 Switch Edges**
- T.2 Switch Levels**
- T.3 Single Switch**
- T.4 Solenoid Test**
- T.5 Flasher Test**
- T.6 General Illumination**
- T.7 Sound & Music Test**
- T.8 Single Lamps**
- T.9 All Lamps**
- T.10 Lamp & Flasher Tests**
- T.11 Display Test**
- T.12 Gun Test**

**Note:** During the Switch Tests, unless otherwise stated, a flashing cross indicates your location in the matrix, a square indicates a closed switch, and a dot indicates an open switch. For all switches, the number on the left indicates the column, the number on the right indicates the row. Example- Switch 23 means 2nd column, 3rd row.

### **T.1 Switch Edges**

To test the Left and Right Flippers, press the Left or Right Flipper buttons during switch test. The flipper name and switch number should show in the display. Any other results indicate the system has detected a problem with the flipper circuit.

To activate the Switch Edges Test, from the Test Menu, press the Enter button. The name and number of each switch that is pressed is shown in the display. If any other switch, or no switch at all is indicated, the system has detected a problem with the switch circuit.

Press Escape to return to the Test Menu. Press the Up button to display the next test, (or the Down button to return to a previous test). Press the Enter button to activate that test.

### **T.2 Switch Levels**

Once the test name is shown under the Test Menu, press the Enter button. The name and number of each switch that is activated is shown in the display. This test automatically cycles through all switches that are detected closed. Current switch is indicated by a filled square.

Press the Escape button to return to the Test Menu. Press the Up button to display the next test, (or the Down button to return to a previous test). Press the Enter button to activate that test.

### **T.3 Single Switches**

Once the test name is shown under the Test Menu, press the Enter button. The Single Switch Test isolates a particular switch by blocking signals from all other switches. Use the Up or Down buttons to select the switch to be tested. Press the Start button to obtain wire color, connector, and fuse information of any switch when that switch is displayed.

Press the Escape button to return to the Test Menu. Press the Up button to display the next test, (or the Down button to return to a previous test). Press the Enter button to activate that test.

# Switch Matrix

White Green

Dedicated Grounded Switches	Column		1	2	3	4	5	6	7	8
	Row		Green-Brown J207-1 U20-18	Green-Red J207-2 U20-17	Green-Orange J207-3 U20-16	Green-Yellow J207-4 U20-15	Green-Black J207-5 U20-14	Green-Blue J207-6 U20-13	Green-Violet J207-7 U20-12	Green-Gray J207-8 U20-11
Orange-Brown Left Coin Chute	1	White-Brown J206-1 U18-11	Right Flipper	Slam Tilt	Gun Loaded	Left Jet	Left Lock	Left Ramp Entry	Target 1 High	Not Used
Orange-Red Center Coin Chute	2	White-Red J206-2 U18-9	Left Flipper	Coin Door Closed	Gun Mark	Right Jet	Not Used	Left Ramp Made	Target 2	Not Used
Orange-Black Right Coin Chute	3	White-Orange J206-3 U18-5	Start Button	Ticket Dispenser	Gun Home	Bottom Jet	Low Escape Route	Right Ramp Entry	Target 3	Not Used
Orange-Yellow 4th Coin Chute	4	White-Yellow J206-4 U18-7	Plumb Bob Tilt	Test Position, Always Closed	Grip Trigger	Left Sling	High Escape Route	Right Ramp Made	Target 4	Not Used
Orange-Green Normal Function   Test Function Service Credits   Escape Credits	5	White-Green J206-5 U18-11	Trough Left	Left Outline	Not Used	Right Sling	Top Lock	Low Chase Loop	Target 5 Low	Not Used
Orange-Blue Normal Function   Test Function Volume Down   Volume Up	6	White-Blue J206-7 U18-9	Trough Center	Left Return Lane	Mid Left Stand-up Target	Top Right Stand-up Target	Top Lane Left	High Chase Loop	Ball Popper	Not Used
Orange-Violet Normal Function   Test Function Volume Up   Volume Down	7	White-Violet J206-8 U18-5	Trough Right	Right Return Lane	Mid Center Stand-up Target	Mid Right Stand-up Target	Top Lane Center	Not Used	Drop Target	Not Used
Orange-Gray Normal Function   Test Function Begin   Enter Test	8	White-Gray J206-9 U18-7	Outlets	Right Outline	Mid Right Stand-up Target	Bot Right Stand-up Target	Top Lane Right	Not Used	Shooter	Not Used

## Switch Matrix Circuit

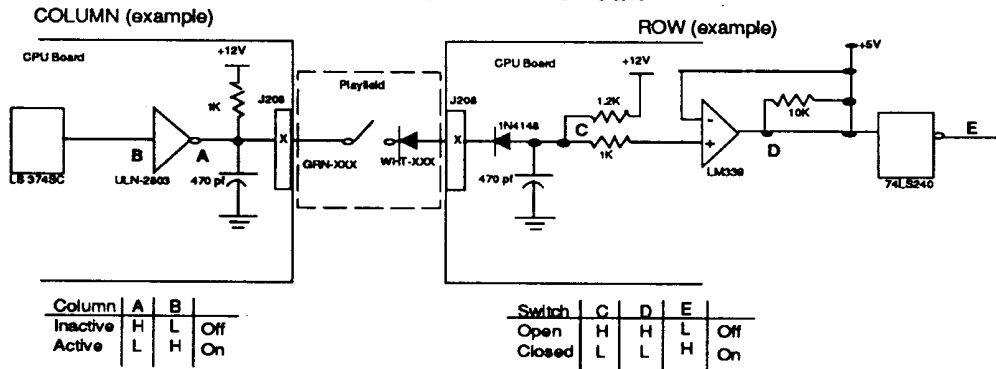

## Dedicated Switch Circuit

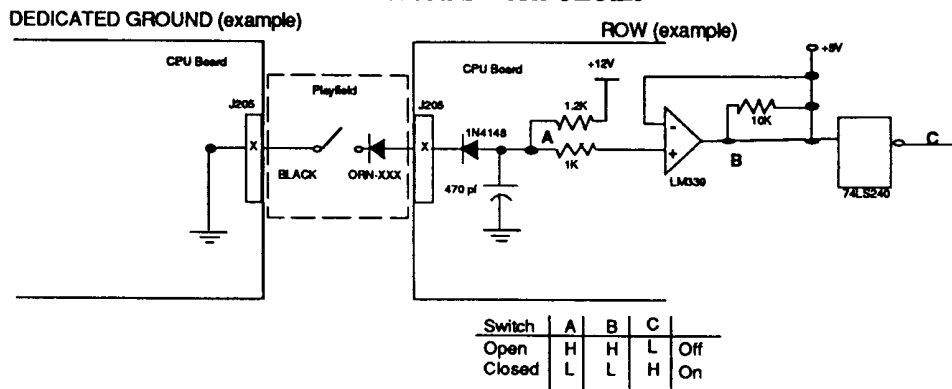

## **T.4 Solenoid Test**

Once the test name is shown under the Test Menu, press the Enter button. The Solenoid Test has three modes, Repeat, Stop, and Running. Only one solenoid should turn On at a time. The system has detected a problem if, more than one solenoid turns On, a solenoid comes On and stays On, or no solenoid turns On during the Repeat or Running test modes. Press the Start button to see the wire color, driver number, connector, and fuse information of any coil, when that coil is displayed.

- Repeat - This test allows you to stop and pulse a single coil or flashlamp. Once you have entered the Solenoid Test, coil 1 shows in the display and the corresponding solenoid activates. Press the Up or Down button to cycle through the solenoids, one at a time, manually. The same solenoid pulses until you press the Up or Down button to move to the next one. Either press the Escape button to return to the Test Menu, or press the Enter button to move to the next test mode.
- Stop - This test allows you to stop the Solenoid Test at any point. Press Enter during the Repeat test mode and the Solenoid Test stops. There should not be any solenoids activated while the test is stopped. Either press the Escape button to return to the Test Menu, or the Enter button to move to the next test mode.
- Running - This test allows you to cycle through the solenoids automatically. Press the Enter button during the Stop test mode. The display shows you the name and number of the solenoid currently being pulsed.

Either press the Enter button to return to the Repeat test mode, or press the Escape button to return to the Test Menu. Once in the Test Menu press, the Up button to display the next test, (or the Down button to return to a previous test). Press the Enter button to activate that test.

## **T.5 Flasher Test**

Once the test name is shown under the Test Menu, press the Enter button. This test allows you to test the flashlamp part of the solenoid circuit exclusively. This test, like the Solenoid Test, has three test modes Repeat, Stop, and Running. During this test, only one flashlamp circuit should turn On at a time. If, more than one flashlamp circuit turns On, or stays On, or no flashlamp circuit turns On at all during the Repeat or Running test modes the system has detected a problem. Press the Start button to see the wire color, driver number, connector, and fuse information of any flashlamp circuit when that circuit appears in the display.

- Repeat - This test allows you to stop and pulse a single flashlamp. Once you have entered the Flasher Test, the name and number of the first flashlamp circuit shows in the display and the corresponding bulb(s) flashes. Press the Up or Down button to cycle through all of the flashlamps circuits one at a time, manually. The same flashlamp circuit pulses until you press the Up or Down button to move to the next one. Either, press the Escape button to return to the Test Menu, or press the Enter button to advance to the next test mode.
- Stop - This test allow you to stop the Flasher Test at any time. Press the Enter button during the Repeat test mode. The Flasher Test stops. There should not be any flashlamp circuit turned On during this test mode. Either press the Escape button to return to the Test Menu, or press the Enter button to advance to the next test mode.
- Running - This test allows you to cycle through the flashlamps automatically. Press the Enter button during the Stop test mode. The display shows you the name and number of the flashlamp currently being pulsed, and the corresponding bulb(s) flashes.

Either press the Enter button to return to the Repeat test mode or, press the Escape button to return to the Test Menu. Once in the Test Menu, press the Up button to display the next test, (or the Down button to return to a previous test). Press the Enter button to activate that test.

### Solenoid Table

Sol. No.	Function	Solenoid Type	Wire Color	Connections Playfield-Insert	Driver Trnstr	Solenoid Part Number Flashlamp Type
01	Ball Popper	High Power	Vio-Brn	J130-1	Q82	AE-23-800
02	Gun Kicker	High Power	Vio-Red	J130-2	Q80	AE-24-900
03	Outhole	High Power	Vio-Orn	J130-4	Q78	AE-27-1200
04	Trough	High Power	Vio-Yel	J130-5	Q76	AE-26-1200
05	Right Sling	High Power	Vio-Grn	J130-6	Q64	AE-26-1500
06	Left Sling	High Power	Vio-Blu	J130-7	Q66	AE-26-1500
07	Knocker	High Power	Vio-Blk	J130-8	Q68	AE-23-800
08	Kickback	High Power	Vio-Gry	J130-9	Q70	AE-23-800
09	Plunger	Low Power	Brn-Blk	J127-1	Q58	AE-23-800
10	Top Lock	Low Power	Brn-Red	J127-3	Q56	AE-26-1500
11	Gun Motor	Low Power	Brn-Orn	J127-4	Q54	14-7963
12	Knock Down	Low Power	Brn-Yel	J127-5	Q52	SM1-26-600
13	Left Jet	Low Power	Brn-Grn	J127-6	Q50	AE-26-1200
14	Right Jet	Low Power	Brn-Blu	J127-7	Q48	AE-26-1200
15	Bottom Jet	Low Power	Brn-Vio	J127-8	Q46	AE-26-1200
16	Left Lock	Low Power	Brn-Gry	J127-9	Q44	AE-26-1500
17	Hot Dog Flashlamps	Flasher	Blk-Brn	J126-1	Q42	#906 (4 PL)
18	Right Sling Flashlamps	Flasher	Blk-Red	J126-2	Q40	#906 (1 BB), #89 (1 PL)
19	Left Sling Flashlamps	Flasher	Blk-Orn	J126-3	Q38	#906 (1 BB), #89 (1 PL)
20	Left Lock Flashlamps	Flasher	Blk-Yel	J126-4	J125-2 Q36	#906 (1 BB), #89 (1 PL)
21	Gun Flashlamps	Special	Blu-Grn	J126-5	J125-3 Q28	#89 (2 PL)
22	Right Ramp Flashlamps	Special	Blu-Blk	J126-6	J125-5 Q30	#906 (1 BB), #89 (1PL)
23	Left Ramp Flashlamps	Special	Blu-Vio	J126-7	Q34	#906 (1 BB), #89 (1 PL)
24	Backglass Flashlamp	Special	Blu-Gry		J125-7 Q32	#906 (1 BB)
25	Targets Flashlamps	Special	Blu-Brn	J122-1	J125-8 Q26	#89 (2 PL)
26	Left Popper Flashlamps	Special	Blu-Red	J122-2	J125-9 Q24	#89 (2 PL)
27	Right Popper Flashlamps	Special	Blu-Orn	J122-3	Q22	#89 (2 PL)
28	Drop Target	Special	Blu-Yel	J122-4	Q20	AE-26-1200
<b>General Illumination</b>						
01	Top Insert G.I.	G.I.	Wht-Brn	J120-7	Q18	#555
02	Left Playfield G.I.	G.I.	Wht-Vio	J119-1	Q10	#555
03	Right Playfield G.I.	G.I.	Wht-Yel	J121-9	Q14	#555
04	Not Used	G.I.	Wht-Orn	J120-8	Q16	
05	Bottom Insert G.I.	G.I.	Wht-Grn	J120-10	Q12	#555
	Lower Right Flipper		Blu-Yel	J109-7		FL-11630
	Lower Left Flipper		Gry-Yel	J109-5		FL-11630



## High Power Solenoid Circuit

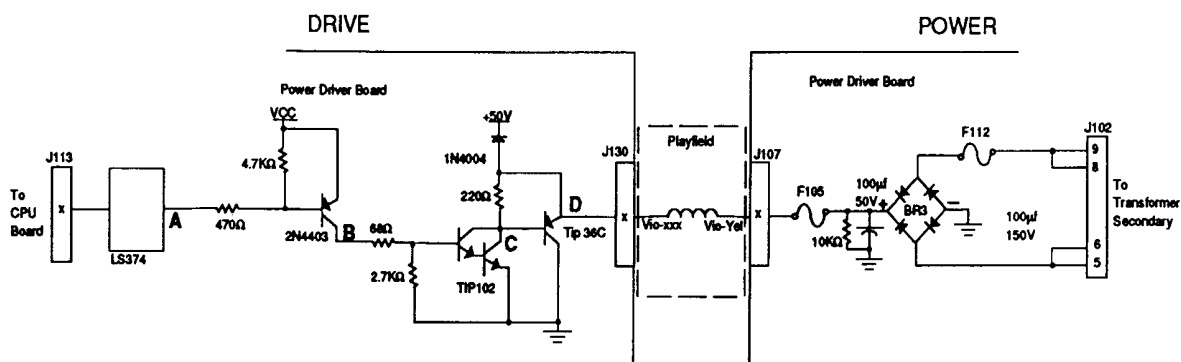

The microprocessor toggles the output of the 74LS374. When point "A" drops low, point "B" the collector of the 2N4403 transistor is high. A high at point "B" causes point "C" the collector of the TIP102 transistor, and point "D" the emitter of the TIP36 transistor to drop low. When point "D" is low the coil is grounded through the transistor and turns On. The coil shuts Off when point "A" toggles high.

## Low Power Solenoid Circuit

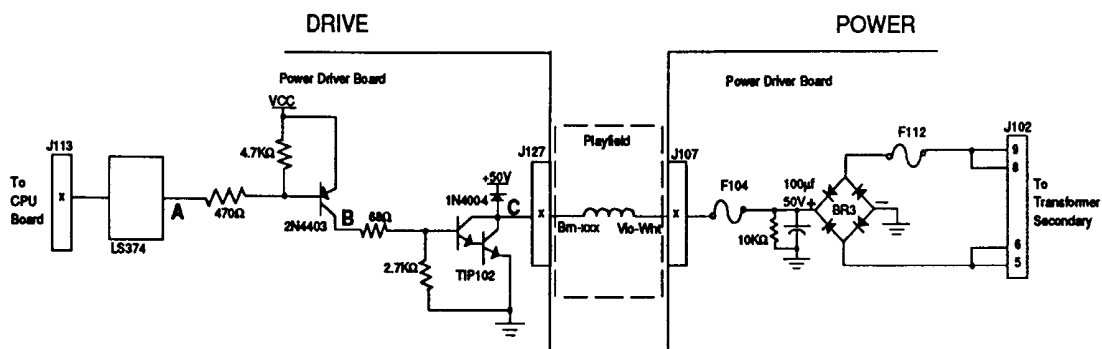

The microprocessor toggles the output of the 74LS374. When point "A" is low, point "B" the collector of the 2N4403 transistor is driver high. A high at point "B" turns On the TIP102 transistor and causes point "C" to drop low. When point "C" is low the coil is grounded through the transistor and turns On. The coil shuts Off when point "A" toggles high.

## Special (General Purpose) Solenoid Circuit

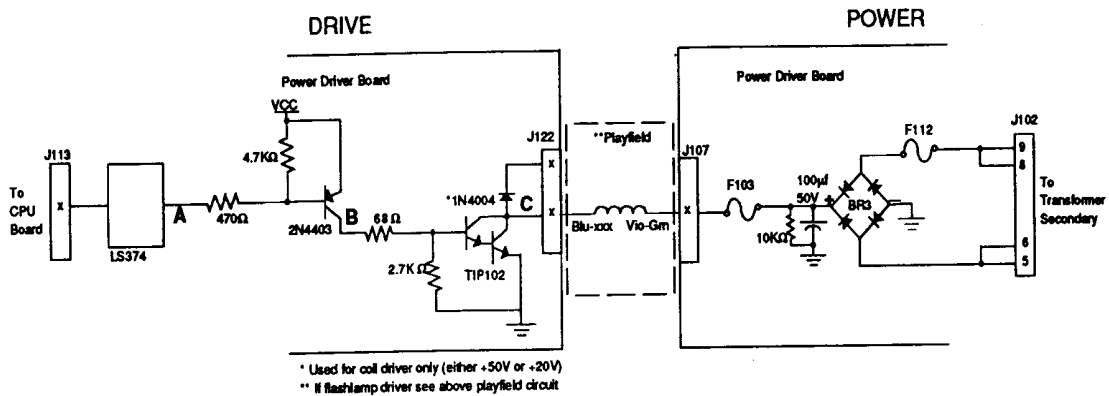

The microprocessor toggles the output of the 74LS374. When point "A" drops low, point "B" is high. A high at point "B" causes a low at point "C". When point "C" is low the coil/flashlamp is grounded through the transistor and turns On. When point "A" toggles high the coil/flashlamp turns Off.

## Flashlamp Circuit

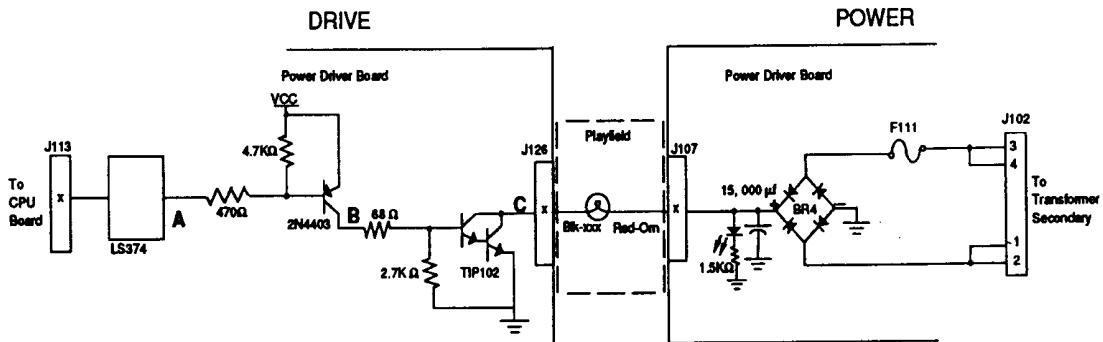

The microprocessor toggles the output of the 74LS374. When point "A" is low, point "B" the collector of the 2N4403 transistor is high. Once point "B" is high, point "C" the collector of the TIP102 transistor is low. When point "C" is low the flashlamp is grounded through the transistor and turns On. When point "A" toggles to a high the circuit shuts Off.

## **T.6 General Illumination**

Once the test name is shown under the Test Menu, press the Enter button. This test allows you to check all of the General Illumination circuits. There are two modes of operation, Stop and Run. To obtain wire color, driver number, connector, and fuse information, press the Start button when the desired General Illumination circuit appears in the display.

**Stop** - Press the Up or Down buttons to cycle through the General Illumination Test manually. All illumination is tested first, followed by an individual circuit test. The circuit name and number shows in the display while the corresponding lamps lights. If any other results occur the system has detected an error.

**Run** - Press the Enter button any time during Stop test mode and the General Illumination Test cycles through automatically. For each circuit shown in the display the corresponding bulbs should light. If any other results occurs the system has detected a problem.

Either press the Enter button to return to Stop test mode, or the Escape button to return to the Test Menu. Once in the Test Menu press the Up button to advance to the next test, (or the Down button to return to a previous test). Press the Enter button to activate that test.

## **T.7 Sound and Music Test**

Once the test name is shown under the Test Menu, press the Enter button. The Sound and Music Test allows you to check the audio circuits. This test has three modes for testing the sound and music circuits, Running, Repeat and Stop.

**Running** - This test steps through a sequence of sounds and music. Pressing the Up or Down button during this portion of the Sound and Music test allows you to advance to a particular sound or tune without having to wait for the program to play all the sounds available in the test. A sound or tune should be heard for each name and number that appears in the display. Any other results indicates the system has detected a problem.

**Repeat** - Press the Enter button at any time during the Running test mode to cause the program to stop and repeat a particular sound or tune. The same sound should repeat continuously until the Up or Down button is pressed. Any other results indicates the system has detected a problem.

**Stop** - Press the Enter button at any time during the Repeat test mode to stop this test altogether. Nothing should be heard. Any other results indicates the system has detected a problem.

Use the Enter button to return to the Running test mode, or the Escape button to return to the Test Menu. Once in the Test Menu press the Up button to display the next test, (or the Down button to return to a previous test) . Press the Enter button to activate that test.

## **T.8 Single Lamp Test**

For all lamps, the number on the left indicates the column, the number on the right indicates the row. Example- Lamp 23 means 2nd column, 3rd row.

Once the test name is shown under the Test Menu, press the Enter button. This test allows you to test each lamp circuit individually. Press the Up or Down button to cycle through this test. For each name and number that is shown in the display the corresponding lamp should light. Any other results indicates the system has detected a problem. Press the Start button to obtain wire color, connector, and fuse information when the desired lamp is lit.

Press the Escape button to return to the Test Menu. Press the Up button to display the next test, (or the Down button to return to a previous test). Press the Enter button to activate that test.

## **T.9 All Lamps Test**

Once the test name is shown under the Test Menu, press the Enter button. This test causes all the controlled lamps to flash at the same time. Every controlled lamp should flash. Any other results indicates the system has detected a problem.

Press the Escape button to return to the Test Menu. Press the Up button to display the next test, (or the Down button to return to a previous test). Press the Enter button to activate that test.

## **T.10 Lamp and Flasher Test**

Once the test name is shown under the Test Menu, press the Enter button. This test causes all the flashlamps and the controlled lamps to flash at the same time. The controlled lamps blink, while the flashlamps cycle from highest to lowest. Any other results indicates the system has detected a problem.

Press the Escape button to return to the Test Menu. Press the Up button to display the next test, (or the Down button to return to a previous test). Press the Enter button to activate that test.

# Lamp Matrix

Yellow (B+) Red

Column \ Row	1 Yellow-Brown J138-1 Q88	2 Yellow-Red J138-2 Q87	3 Yellow-Orange J138-3 Q86	4 Yellow-Black J138-4 Q85	5 Yellow-Green J138-5 Q84	6 Yellow-Blue J138-6 Q83	7 Yellow-Violet J138-7 Q82	8 Yellow-Gray J138-8 Q81
1 Red-Brown J133-1 Q80	Multiplier 2K 11	Kickback 21	Target 1 High 31	Lock Two 41	Eyes Lower 51	Left CPU Lit 61	Right CPU Lit 71	Chase Value 81
2 Red-Black J133-2 Q89	Multiplier 4K 12	Special 22	Target 2 32	Data Base 2 42	Eyes Upper 52	Left Vault Key 62	Right Vault Key 72	Right Ramp 82
3 Red-Orange J133-4 Q88	Hold Bonus 13	Left Return Lane 23	Target 3 33	10 Million 43	5,000,000 53	Left Silent Alarm 63	Right Silent Alarm 73	Hurry Up 83
4 Red-Yellow J133-5 Q87	Multiplier 6K 14	Right Return Lane 24	Target 4 34	Extra Ball 44	3,000,000 54	Left Passcode 64	Right Passcode 74	Start Button 84
5 Red-Green J133-6 Q86	Multiplier 8K 15	Data Base 3 25	Target 5 Low 35	Multi-ball 45	1,000,000 55	Left Checkpoint 65	Right Checkpoint 75	Drop Target 85
6 Red-Blue J133-7 Q85	Shoot Again 16	Load Gun 26	Middle Target Bank Left 36	Light Hurry Up 46	750,000 56	Lock 1 66	Right Bank Top 76	Top Lane Left 86
7 Red-Violet J133-8 Q84	Mouth 17	Extra Ball 27	Middle Target Bank Center 37	Hold Bonus 47	500,000 57	Data Base 1 67	Right Bank Middle 77	Top Lane Center 87
8 Red-Gray J133-8 Q83	Not Used 18	Load for Jackpot 28	Middle Target Bank Right 38	Security Pass 48	250,000 58	Left Ramp 68	Right Bank Bottom 78	Top Lane Right 88

## Lamp Circuit

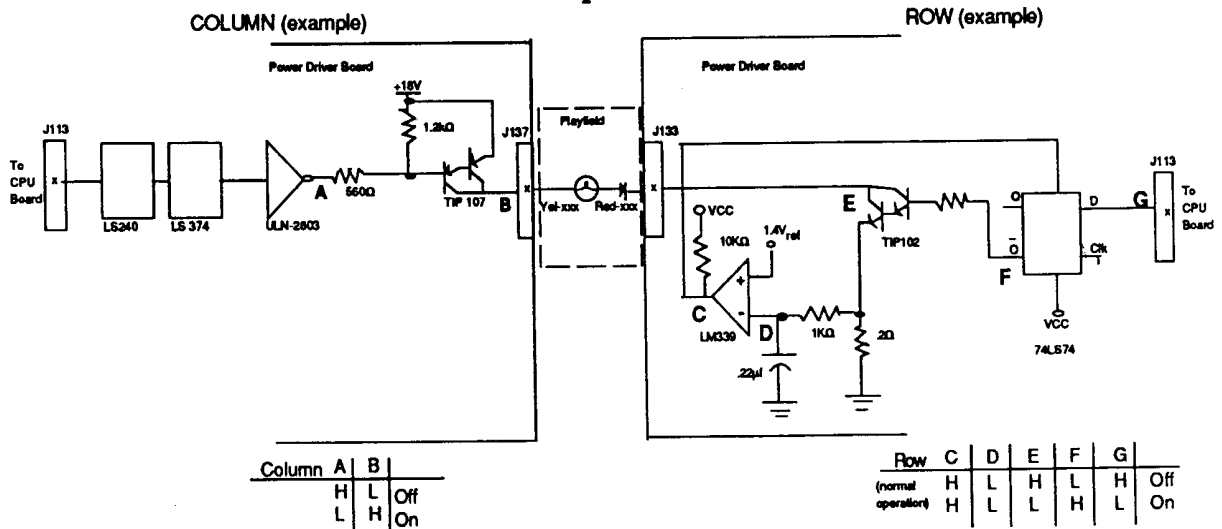

## T.11 Display Test

Once the test name is shown under the Test Menu, press the Enter button. This test automatically turns On and Off every dot in the Dot Matrix Display. A series of patterns appear in sequence. The patterns start with one line, turned On, moving across the screen vertically, then horizontally. The screen inverts and one line, turned Off, moves across the screen vertically, then horizontally. The second pattern is a series of lines, turned On, moving across the screen diagonally. The screen inverts and there is a series of lines, turned Off, moving across the screen diagonally. The third pattern is gridlines turned On, then turned Off. The last pattern is a box forming an outline of dots around the matrix that are turned On. After the box outline the test repeats itself.

Press the Escape button to return to the Test Menu. Press the Up button to display the next test, (or the Down button to return to a previous test). Press the Enter button to activate that test.

## T.12 Gun Test

The Gun Test allows you to test the Gun switches, motor and alignment. During the Gun Test the screen shows:

<b>Gun Test</b>	
Motor On/Off	(Not ) Home
(No) Ball	(Not ) At Mark

Ball - There is a ball in the Gun Kicker, (the Gun is loaded).

No Ball - There is no ball in the Gun Kicker, (the Gun is not loaded).

At Home - The Home Switch is closed and the Gun is aligned with the ramp (as far to the right as possible).

Not At Home - The Home Switch is open and the Gun is not aligned with the ramp.

At Mark - The Mark Switch is open and the Gun is aimed at the bottom of the left ramp and above the Top Stand-up 5-bank Target.

Not At Mark - The Mark Switch is not open and the Gun is not aimed.

Press the Down button to automatically move the Gun to the next position (Home or Mark).

Press the Up button to manually move the Gun to the next position. The Gun moves as long as the Up button is pressed. As soon as the Up button is released, the Gun stops moving. Press the Escape button to put the Gun in a Self-calibrating Mode. Press the Enter button to fire the Gun and check its alignment.

Press the Escape button to return to the Test Menu. Then, either press the Up or Down button to return to a previous Test, or press the Escape button again to return to the Main Menu. Once in the Main Menu, press the Up button to move to the next menu selection, the Utilities Menu, or press the Down button to return to a previous Main Menu selection.

Press the Enter button to activate the Utilities Menu, once the menu name is shown under the Main Menu. Then, use the Up or Down button to cycle through the Utility Menu selections. Press the Enter button to activate the desired Utility or Utility Group when it appears in the display. If you change a utility setting and realize you have made a mistake, press the Escape button while "Saving Adjustment Value" is still in the display. The original setting is retained and the new setting is ignored.

## **U. UTILITIES MENU**

- U.1 Clear Audits**
- U.2 Clear Coins**
- U.3 Reset H.S.T.D.**
- U.4 Set Time & Date**
- U.5 Custom Message**
- U.6 Set Game I.D.**
- U.7 Factory Adjustments**
- U.8 Factory Resets**
- U.9 Presets**
- U.10 Clear Credits**
- U.11 Auto Burn-in**

### **U.1 Clear Audits**

Press the Enter button to clear the Standard Audits, Feature Audits, and Histograms. Press the Up button to display the next utility.

### **U.2 Clear Coins**

Press the Enter button to clear the Earnings Audits. Press the Up button to display the next utility.

### **U.3 Reset H.S.T.D.**

Press the Enter button to clear the High Score to Date Table and the Grand Champion. Press the Up button to display the next utility.

### **U.4 Set Time and Date**

Press the Enter button to activate the time and date. Use the Up or Down button to change the value, then press the Enter button to lock in that value. If you make a mistake press the Escape button while "Saving Adjustment Value" is displayed. The new value is ignored and the original value is retained. Press the Up button to move to the next utility.

### **U.5 Custom Message**

This utility allows the operator to install a message that appears in the displays during the Attract Mode. Press the Enter button to activate the Custom Message. Use the Up or Down button to rotate letters. Use the Start button to rotate punctuation marks, (if desired). Press the Enter button to lock in the desired letter and punctuation. Note: Set Adjustment A.1 20 to YES before trying to write a Custom Message.

### **U.6 Set Game I.D.**

This utility allows the operator to install a message, such as game location, that only appears on printouts. Press the Enter button to activate Set Game I.D.. Use the Up or Down button to rotate letters. Use the Start button to rotate punctuation marks, (if desired). Press the Enter button to lock in the desired letter and punctuation.

## U.7 Factory Adjustment

Press the Enter button to restore the adjustments to factory settings, then press the Up button to display the next utility.

### Factory Settings Table

Adj #	Adj Description	U.S.A.	German	French	European
A.1 06	Replay Percent	10%	10%	10%	10%
A.1 09	Replay Level 1	30,000,000	40,000,000	40,000,000	40,000,000
A.1 13	Replay Boost	5,000,000	5,000,000	5,000,000	5,000,000
A.4 10	Backup Champion	150,000,000	150,000,000	150,000,000	150,000,000
A.4 11	Backup H.S.T.D. 1	90,000,000	100,000,000	100,000,000	100,000,000
A.4 12	Backup H.S.T.D. 2	70,000,000	80,000,000	80,000,000	80,000,000
A.4 13	Backup H.S.T.D. 3	50,000,000	60,000,000	60,000,000	60,000,000
A.4 14	Backup H.S.T.D. 4	30,000,000	40,000,000	40,000,000	40,000,000

## U.8 Factory Reset

Press the Enter button to restore the adjustments to their factory setting, clear the Audits, H.S.T.D Table, and Custom Message/Game I.D. Press the Up button to display the next utility.

## U.9 Presets

Press the Enter button to activate the Presets Group. Use the Up or Down buttons to cycle through the available Presets. When the desired Preset is displayed, press the Enter button to lock in that Preset. If you realize you have made a mistake, press the Escape button while "Saving Adjustment Value" is displayed. The new value is ignored and the original value is retained.

### U.9 01 Install Extra Easy

The operator can change the game play difficulty adjustments to a combination that is MUCH LESS difficult than the Factory Settings. The Game Difficulty Setting Table lists the adjustments and the settings that comprise the 'Extra Easy' Group.

### U.9 02 Install Easy

The operator can change the game play difficulty adjustments to a combination that is somewhat LESS difficult than the Factory Settings. The Game Difficulty Setting Table lists the adjustments and the settings that comprise the 'Easy' Group.

### U.9 03 Install Medium

The operator can change the game play difficulty adjustments to a combination that is about the SAME difficulty as the Factory Settings. The Game Difficulty Setting Table lists the adjustments and settings that comprise the 'Medium' Group.

### U.9 04 Install Hard

The operator can change the game play difficulty adjustments to a combination that is somewhat MORE difficult than Factory Settings. The Game Difficulty Setting Table lists the adjustments and settings that comprise the 'Hard' Group.



**U.9 05 Install Extra Hard**

The operator can change the game play difficulty adjustments to a combination that is MUCH MORE difficult than Factory Settings. The Game Difficulty Setting Table lists the adjustments and settings that comprise the 'Extra Hard' Group.

**Game Difficulty Setting Table for U.S. / Canadian / French Games**

Adj #	Adj Description	Extra Easy U.9 01	Easy U.9 02	Medium U.9 03 (factory)	Hard U.9 04	Extra Hard U.9 05
A.2 02	Extraball Percent	20%	15%	10%	10%	7%
A.2 03	Extraball Memory	On	On	On	On	Off
A.2 04	Consolation Ball	On	On	On	Off	Off
A.2 05	Drop Target Count	2	2	1	1	0
A.2 06	3-bank Count	4	3	2	1	0
A.2 07	Kickback Setting	Extra Easy	Easy	Med	Hard	Ex. Hard
A.2 08	Skill Shot Timer	1-1/4 sec	1 sec	3/4 sec	1/2 sec	1/4 sec
A.2 09	Drop Target Timer	25 sec	20 sec	15 sec	10 sec	10 sec
A.2 10	3-bank Timer	25 sec	20 sec	15 sec	10 sec	10 sec
A.2 11	Hurry-up Timer	20 sec	15 sec	10 sec	10 sec	10 sec
A.2 12	Payback Timer	30 sec	25 sec	20 sec	15 sec	10 sec
A.2 13	Jackpot Timer	25 sec	20 sec	15 sec	15 sec	10 sec
A.2 14	Million Plus	On	On	On	Off	Off

**Game Difficulty Setting Table for German/European Games**

Adj #	Adj Description	Extra Easy U.9 01	Easy U.9 02	Medium U.9 03 (factory)	Hard U.9 04	Extra Hard U.9 05
A.2 02	Extraball Percent	15%	10%	10%	7%	5%
A.2 03	Extraball Memory	On	On	On	Off	Off
A.2 04	Consolation Ball	On	On	Off	Off	Off
A.2 05	Drop Target Count	2	1	1	0	0
A.2 06	3-bank Count	3	2	1	0	0
A.2 07	Kickback Setting	Ex. Easy	Easy	Med	Hard	Ex. Hard
A.2 08	Skill Shot Timer	1 sec	3/4 sec	1/2 sec	1/4 sec	1/4 sec
A.2 09	Drop Target Timer	20 sec	15 sec	10 sec	10 sec	8 sec
A.2 10	3-bank Timer	20 sec	15 sec	10 sec	10 sec	8 sec
A.2 11	Hurry-up Timer	15 sec	10 sec	10 sec	10 sec	7 sec
A.2 12	Payback Timer	25 sec	20 sec	15 sec	10 sec	10 sec
A.2 13	Jackpot Timer	20 sec	15 sec	15 sec	10 sec	10 sec
A.2 14	Million Plus	On	On	On	Off	Off

**U.9 06 Install 5 Ball**  
 The operator can change the game to 5 ball play, including the changing of certain features to the recommended 5-ball level. The Preset Game Adjustments Table for U.S./Canadian Games lists the adjustments and settings that comprise the 'Install 5 Ball' Group.

**U.9 07 Install 3 Ball**  
 The operator can change the game to 3 ball play, including the changing of certain features to the recommended 3-ball level. The Preset Game Adjustments Table for U.S./Canadian Games lists the adjustments and settings that comprise the 'Install 3 Ball' Group.

**Preset Game Adj's Table for U.S./ Canadian Games**

Adj #	Adj Description	Install 5-ball U.9 06	Install 3-ball U.9 07
A.1 01	Balls/Game	5	3
A.1 07	Replay Start	50,000,000	30,000,000
A.2 06	3-bank Drop Tgt Timer	10 sec	15 sec
A.2 10	3-bank Count	1	2

**U.9 08 Install Add -A -Ball**  
 The operator utilizes this option to delete all Free Play awards and replace them with Extra Ball awards. Individual adjustments are affected, as follows:

<u>Ad</u>	<u>Name</u>	<u>New Setting</u>
A.1 13	Replay Boost	Off
A.1 14	Replay Award	Ex. Ball
A.1 15	Special Award	Ex. Ball
A.1 17	Extra Ball Ticket	No
A.1 19	Match Feature	Off
A.4 04	Champion Credits	00
A.4 05	High Score 1 Credits	00
A.4 06	High Score 2 Credits	00
A.4 08	High Score 3 Credits	00
A.4 07	High Score 4 Credits	00

**U.9 09 Install Ticket**  
 The operator utilizes this option to delete Credit awards and replace them with Ticket awards. Individual adjustments are affected as follows.

<u>Ad</u>	<u>Name</u>	<u>New Settings</u>
A.1 14	Replay Award	Ticket
A.1 15	Special Award	Ticket
A.1 16	Match Award	Ticket
A.1 17	Ex. Ball Ticket	Yes
A.4 02	H.S.T.D. Award	Ticket

**U.9 10 Install Novelty**

The operator utilizes this option to removes all Free Play and Extra Ball awards. Individual adjustments are affected as follows:

<u>Ad</u>	<u>Name</u>	<u>New Setting</u>
A.1 04	Max. Ex. Ball	Off
A.1 05	Replay System	Fixed
A.1 09	Replay Level 1	Off
A.1 10	Replay Level 2	Off
A.1 11	Replay Level 3	Off
A.1 12	Replay Level 4	Off
A.1 15	Special Award	Points
A.1 19	Match Feature	Off
A.4 01	Highest Score	On
A.4 04	Champion Credits	00
A.4 05	High Score 1 Credits	00
A.4 06	High Score 2 Credits	00
A.4 07	High Score 3 Credits	00
A.4 08	High Score 4 Credits	00

**U.9 11 Install Buy-in**

The operator uses this option to automatically set game pricing to 1 for 50¢/2 for \$1.00 and 1 Coin Buy-in (A.3 19) to YES.

- U.9 17 Install German 1•**  
The operator uses this adjustment to modify the game pricing and the type of game play. The Preset Game Adjustments Table for German Games lists the adjustments and settings that comprise the 'Install German 1' Group.
- U.9 18 Install German 2•**  
The operator uses this adjustment to modify the game pricing and the type of game play. The Preset Game Adjustment Table for German Games lists the adjustments and settings that comprise the 'Install German 2' Group.
- U.9 19 Install German 3•**  
The operator uses this adjustment to modify the game pricing and the type of game play. The Preset Game Adjustments Table for German Games lists the adjustments and settings that comprise the 'Install German 3' Group.
- U.9 20 Install German 4•**  
The operator uses this adjustment to modify the game pricing and the type of game play. The Preset Game Adjustments Table for German Games lists the adjustments and settings that comprise the 'Install German 4' Group.
- U.9 21 Install German 5•**  
The operator uses this adjustment to modify the game pricing and the type of game play. The Preset Game Adjustments Table for German Games lists the adjustments and settings that comprise the 'Install German 5' Group.
- U.9 22 Install German 6•**  
The operator uses this adjustment to modify the game pricing and the type of game play. The Preset Game Adjustments Table for German Games lists the adjustments and settings that comprise the 'Install German 6' Group.

**Preset Game Adjustments Table for German Games**

Adj #	Adj Description	German 1 U.9 17	German 2 U.9 18	German 3 U.9 19	German 4 U.9 20	German 5 U.9 21	German 6 U.9 22
A.1 14	Replay Award	Credit	Ticket	Audit	Credit	Ticket	Audit
A.1 15	Special Award	Credit	Ex. Ball	Points	Credit	Ex. Ball	Points
A.1 16	Match Award	Credit	Ticket	Credit	Credit	Ticket	Credit
A.1 19	Match Feature	7 %	7 %	Off	7 %	7 %	Off
A.3 01	Game Pricing	6 spiele/5 DM	6 spiele/5 DM	6 spiele/5 DM	7 spiele/5 DM	7 spiele/5 DM	7 spiele/5 DM
A.4 02	H.S.T.D. Award	Credit	Ticket	Credit	Credit	Ticket	Credit
A.4 04	Champion Credits	03	03	00	03	03	00
A.4 05	High Score 1 Credits	01	01	00	01	01	00
A.4 06	High Score 2 Credits	00	00	00	00	00	00
A.4 07	High Score 3 Credits	00	00	00	00	00	00
A.4 08	High Score 4 Credits	00	00	00	00	00	00
A.4 10	Backup Champion	150,000,000	150,000,000	00	150,000,000	150,000,000	00
A.4 11	Backup High Score 1	100,000,000	100,000,000	00	100,000,000	100,000,000	00
A.4 12	Backup High Score 2	80,000,000	80,000,000	00	80,000,000	80,000,000	00
A.4 13	Backup High Score 3	60,000,000	60,000,000	00	60,000,000	60,000,000	00
A.4 14	Backup High Score 4	40,000,000	40,000,000	00	40,000,000	40,000,000	00

- For German Jumpered CPU Boards only. German Jumpers are:  
W14   W15   W16   W17   W18  
 In   In   In   In   Out

- U.9 23 **Install French 1\***  
The operator uses this adjustment to modify the game pricing and the type of game play. The Preset Game Adjustments Table for French Games lists the adjustments and setting that comprise the 'Install French 1' Group.
- U.9 24 **Install French 2\***  
The operator uses this adjustment to modify the game pricing and the type of game play. The Preset Game Adjustments Table for French Games list the adjustments and settings that comprise the 'Install French 2' Group.
- U.9 25 **Install French 3\***  
The operator uses this adjustment to modify the game pricing and the type of game play. The Preset Game Adjustments Table for French Games list the adjustments and settings that comprise the 'Install French 3' Group.
- U.9 26 **Install French 4\***  
The operator uses this adjustment to modify the game pricing and the type of game play. The Preset Game Adjustments Table for French Games lists the adjustments and setting that comprise the 'Install French 4' Group.
- U.9 27 **Install French 5\***  
The operator uses this adjustment to modify the game pricing and the type of game play. The Preset Game Adjustments Table for French Games lists the adjustments and settings that comprise the 'Install French 5' Group.
- U.9 28 **Install French 6\***  
The operator uses this adjustment to modify the game pricing and the type of game play. The Preset Game Adjustments Table for French Games lists the adjustments and settings that comprise the 'Install French 6' Group.

**Preset Game Adjustments Table for French Games**

Adj #	Adj Description	French 1 U.9 23	French 2 U.9 24	French 3 U.9 25	French 4 U.9 26	French 5 U.9 27	French 6 U.9 28
A.3 16	Max. Credits	20	28	12	16	20	12

**\*For French Jumpered CPU Boards only. French Jumpers are:**  
W14  
In
W15  
In
W16  
In
W17  
Out
W18  
In

Press the Escape button to return to the Presets menu. Then press the Up button to display the next utility, (or the Down button to return to a previous utility).

**U.10 Clear Credits**

Press the Enter button to clear the game Credits. Press the Up button to display the next utility.

**U.11 Auto Burn-in**

Press the Enter button to activate Auto Burn-in. This utility allows you to automatically cycle through several tests. This helps in finding intermittent problems. The tests that Auto Burn-in cycles through are the Display Test, the Sound and Music Test, the All Lamps Test, the Solenoid Test, the Flashers Test, and the G.I. Test.

Press the Escape button to return to the Utilities Menu. Then, either press the Up or Down button to return to a previous Utilities Menu Group, or press the Escape button again to return to the Main Menu. Once in the Main Menu either use the Up or Down buttons to return to a previous menu selection, or press the Escape button again to return to the Attract Mode.

## Problem Analysis Messages

The WPC game program has the capability to aid the operator and service personnel. At Game Turn-on, or after pressing the Begin Test switch, once the game has been operating for an extended period, the display may signal with a message, "Press ENTER for Test Report". This indicates that the game program has detected a possible problem with the game.

To obtain details of the problem, open the coin door and press the Begin Test switch. Press the Enter button to begin displaying the message(s). The following messages apply to your **Terminator 2** game.

### **Check Switch ##.**

This message indicates that at least one switch was stuck 'On' at game turn-on or has NOT been actuated during ball play (for 90 balls or ~30 games) by displaying the message "Adjust Switch ##", listing each problem switch by number. (The game program compensates the game play requirements affected by each disabled switch to allow 'nearly normal' play. This helps keep **Terminator 2** earning, until the service technician can repair the problem, bringing the game back to its normal operation.)

To verify the problem, refer to the Test Menu text describing Switch Testing, and check each reported switch using applicable switch tests. Always check switch operation using a ball, to simulate game conditions. (Switch problems may often be resolved by adjusting the wire switch actuators, fixing switch circuitry problems, securing loose connectors, etc. Mechanisms using 'opto switches' (drop targets, etc.) need to be checked for proper power connections (+12V dc and ground).

### **Pinball Missing.**

**Terminator 2** normally uses three balls; however, it will operate with one or two balls. This message announces that a ball is missing or stuck somewhere. When the ball is located, return it to the game via the Outhole. Other possibilities for this problem could be malfunctions of the Ball Trough switches or the Ball Shooter switch.

### **xxxx Sw. is Stuck On.**

This message indicates that a switch, which is not usually On, remains in the On position after the game is switched On. The stuck switch is essential for game play (for example, a coin chute switch, the slam tilt switch, the plumb bob tilt switch), and should be cleared to permit proper game operation.

### **Ground Short Row-N, Wht-xxx .**

Frequent appearance of this message requires activation of the Switch Levels Test to locate the switch causing the "WHT-xxx ROW x SHORT" message. Possible 'row short' causes are: 1) Slam Tilt (or other coin door) switch touching the grounded coin door; 2) A *leaf-type*, playfield switch touching a grounded part; 3) Players poking metallic objects (wires, coat hangers, etc.) into the game; 4) Switch cable insulation pierced or damaged allowing bare wire contact with a grounded part; 5) All switches in a row closing at the same time (Note: This instance is NOT a switch problem; however, for most games this is a very rare possibility).

**Factory Settings Restored.**

This message indicates that the CMOS RAM no longer retains any custom Pricing or Game Adjustment settings and has reverted to factory default settings. Generally, the following CPU checks will isolate the cause of the CMOS RAM memory failure. The voltage at pin 28 and pin 26 of U8 should be +5V (game turned On) and at least +4V (game turned Off). When the voltage drops below +4V, memory reset occurs. Check the batteries and battery holder. Be sure that the batteries are good and that there is no contamination on the battery holder terminals. Turn the game OFF, and use an ohmmeter to check diodes D1 and D2 on the CPU Board. D1 should read 0 ohms when forward-biased and infinite ohms when reverse-biased. D2 should read 15 ohms when forward-biased and infinite ohms when reverse-biased.

**U6 Checksum Error.**

The game ROM checksum is invalid. If this occurs replace the game ROM.

**Time and Date Not Set.**

The real time clock is not running. If this occurs go to U.4 of the Utilities Menu and set the time and date.

**Gun Cannot Find Home.**

The Gun Home switch needs attention. The switch is either out of alignment, or a chip (U20, U18) on the CPU Board is bad, or one of the Gun Switch wires (Green-Orange, White - Orange) are not connected to the switch or are open between the switch and the CPU Board.

**CPU L.E.D.s**

The CPU has three L.E.D.s located on the upper left side of the board D19, D20, and D21. On game power-up D19 and D21 turn On for a moment then, D19 turns Off and D20 starts to blink rapidly. D21 remains On. The system has detected a problem if the following happens:

**CPU Board L.E.D. Error Codes**

D20 blinks one time -	ROM Error U6
D20 blinks two times -	RAM Error U8
D20 blinks three times -	Custom Chip Failure U9

**Sound Board Beep Error Codes**

**Upon Game Turn-On:**

1 Beep	=	Sound Board O.K.
2 Beeps	=	Sound RAM Failure
3 Beeps	=	U18 Failure
4 Beeps	=	U15 Failure
5 Beeps	=	U14 Failure (If used)

**REMEMBER: A FULLY FUNCTIONING GAME ALWAYS EARNS MORE THAN ONE WITH PROBLEMS.**

## **Maintenance Information**

Regular maintenance is essential to a game's continuing contribution to the operator's earnings.

### **LUBRICATION**

The two main lubrication points of the Ball Shooter Lane Feeder mechanism are the pivots for the arm. Note that the mechanism of other playfield devices are somewhat similar to the Ball Shooter Lane Feeder Device; and have the same lubrication requirements as the Ball Shooter Lane Feeder Device. A medium viscosity oil (20W or 30W) is satisfactory for these devices.

Because of the functional design (arm-actuated via solenoid plunger operation), the pivot points of the Left and Right Kickers ("Slingshots") all require lubrication as a regular servicing procedure.

Lubrication to ensure proper operation also applies to the target blades of the Drop Targets. MBI Instrument Grease, also known as Drop Target Switch Lubricant, with a Williams' part number of EI165, is a recommended lubricant.

### **SWITCH CONTACTS**

For proper game operation, switch contacts should be free of dust, dirt, contamination, and corrosion. Blade switch contacts are plated to resist corrosion. Cleaning blade switch contacts requires gentle closing of the contacts on a clean business card or piece of paper, and then pulling the paper about 2 inches, which should restore the clean contact surface. Adjust the switch contacts to a 1/16-inch gap.

### **CLEANING**

Good game action and extended playfield life are the results of regular playfield cleaning. During each collection stop, the playfield glass should be removed and thoroughly cleaned and the playfield should be wiped off with a clean, lint-free cloth. The game balls should be cleaned and inspected for any chips, nicks, or pits. Replace any damaged balls to prevent playfield damage.

Regular, more extensive, playfield cleaning is recommended. However, avoid excessive use of water and caustic or abrasive cleaners because they tend to damage the playfield surface. Playfield wax (or any carnauba based wax), or polish may be used sparingly, to prevent a buildup on the playfield surface. Do not use cleaners containing petroleum distillates on any playfield plastics because they may dissolve the plastic material or damage the artwork.

**CLEAN GAMES EARN MORE MONEY!**



## Fuse List

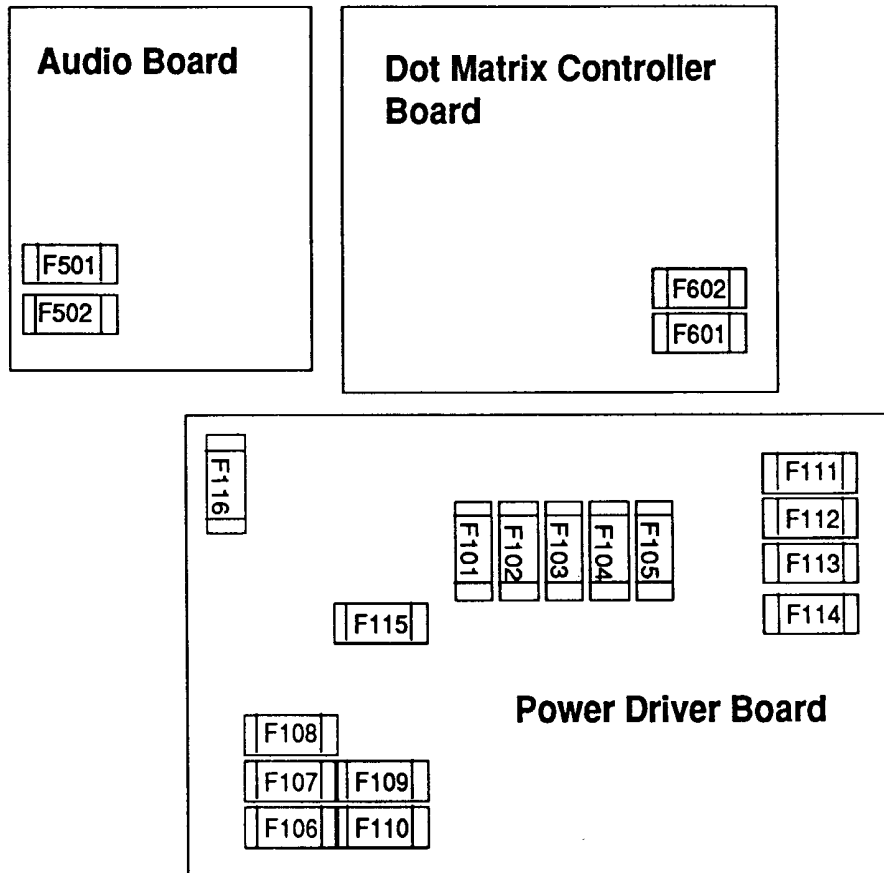

### Audio Board

F501 -25V Circuit 3A, S.B.

F502 +25V Circuit 3A, S.B.

### Dot Matrix Controller Board

F601, +62V Circuit, 3/8A, S.B.

F602, -113V and -125V Circuits, 3/8A S.B.

### Power Driver Board

F101 Left Flipper 2.5A, S.B.

F102 Right Flipper 2.5A, S.B.

F103 Solenoid 25-28 3A, S.B.

F104 Solenoids 9-16 3A, S.B.

F105 Solenoids 1-8 3A, S.B.

F106 G.I. #2 Wht-Vio 5A, S.B.

F107 G.I. #3 Wht-Yel 5A, S.B.

F108 G.I. #5 Wht-Grn 5A, S.B.

F109 G.I. #4 Wht-Orn 5A, S.B.

F110 G.I. #1 Wht-Brn 5A, S.B.

F111 Flasher Secondary 5A, S.B.

F112 Solenoid Secondary 5A, S.B.

F113 +5V Logic 5A, S.B.

F114 +18V Lamp Matrix 8A, N.B.

F115 +12V Switch Matrix 3/4A, S.B.

F116 +12V Secondary 3A, S.B.

### Line Filter

Domestic Game 8A, N.B.

Foreign Game 4A, S.B.

## LED List

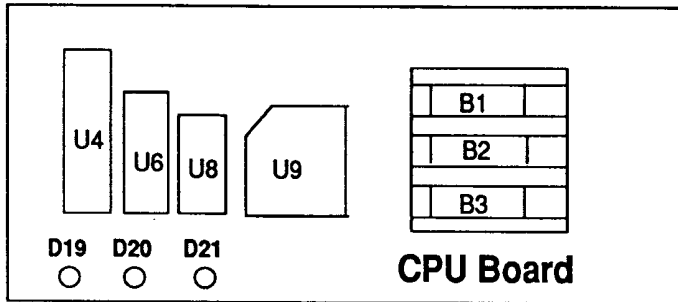

### CPU Board

D19 , Blanking

D20, Diagnostic

D21, +5vdc

At game Turn-On = D19 & D21 On, D20 Off

During Normal Operation = D19 Off, D20 Flashing, D21 On

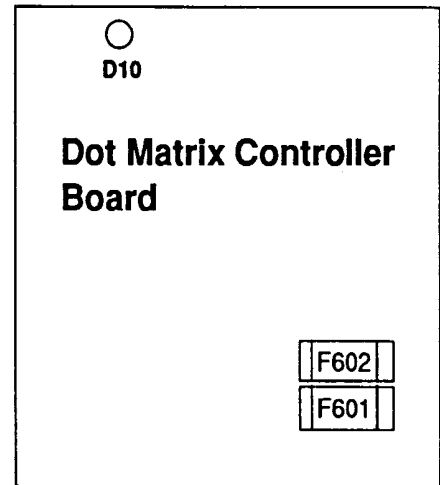

### Dot Matrix Controller Board

D10, +5V Circuit, Normally On

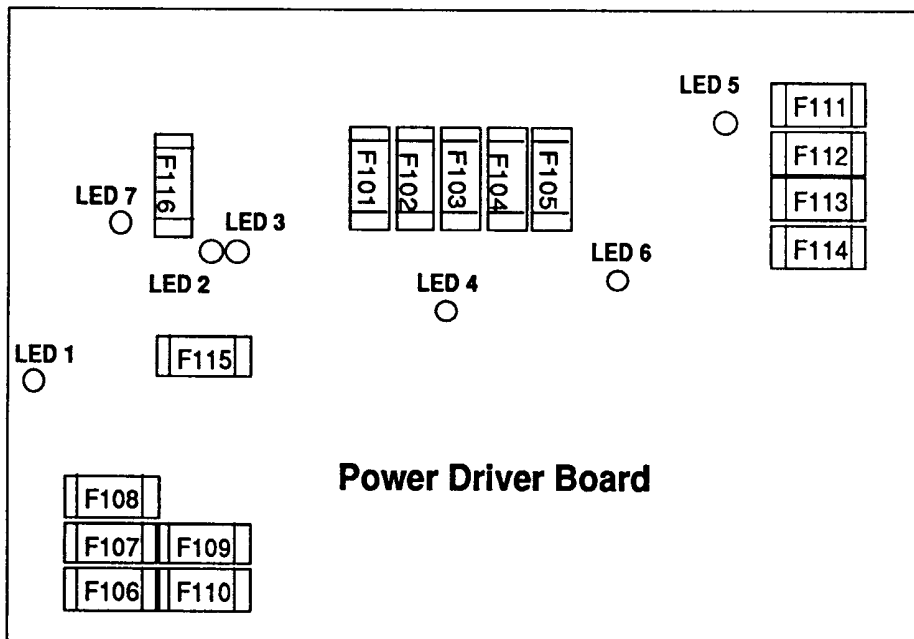

### Power Driver Board

LED 1, +12vdc Switch Circuit, Normally On

LED 2, High/Low Line Voltage Sensor, Normally On

LED 3, High/Low Line Voltage Sensor, Normally Off

LED 4, +5vdc, Digital Circuit, Normally On

LED 5, +20vdc, Flashlamp Circuit, Normally On

LED 6, +18vdc, Lamps Circuit, Normally On

LED 7, +12vdc, Power Circuit (motors relays etc.), Normally On

# **Section 2**

## ***Parts Information***

**Cabinet Parts**

**Major Mechanism Locations Diagram**

**Audio Board**

**CPU Board**

**Power Driver Board**

**Dot Matrix Controller Board**

**Lamp Boards**

**Coin Door Interface Board**

**Motor Regulator Board**

**Major Mechanism Assemblies**

**Rubber Rings**

**Lamps**

**Switches**

**Solenoid/Flashers**

**Playfield Parts**

## Cabinet Parts

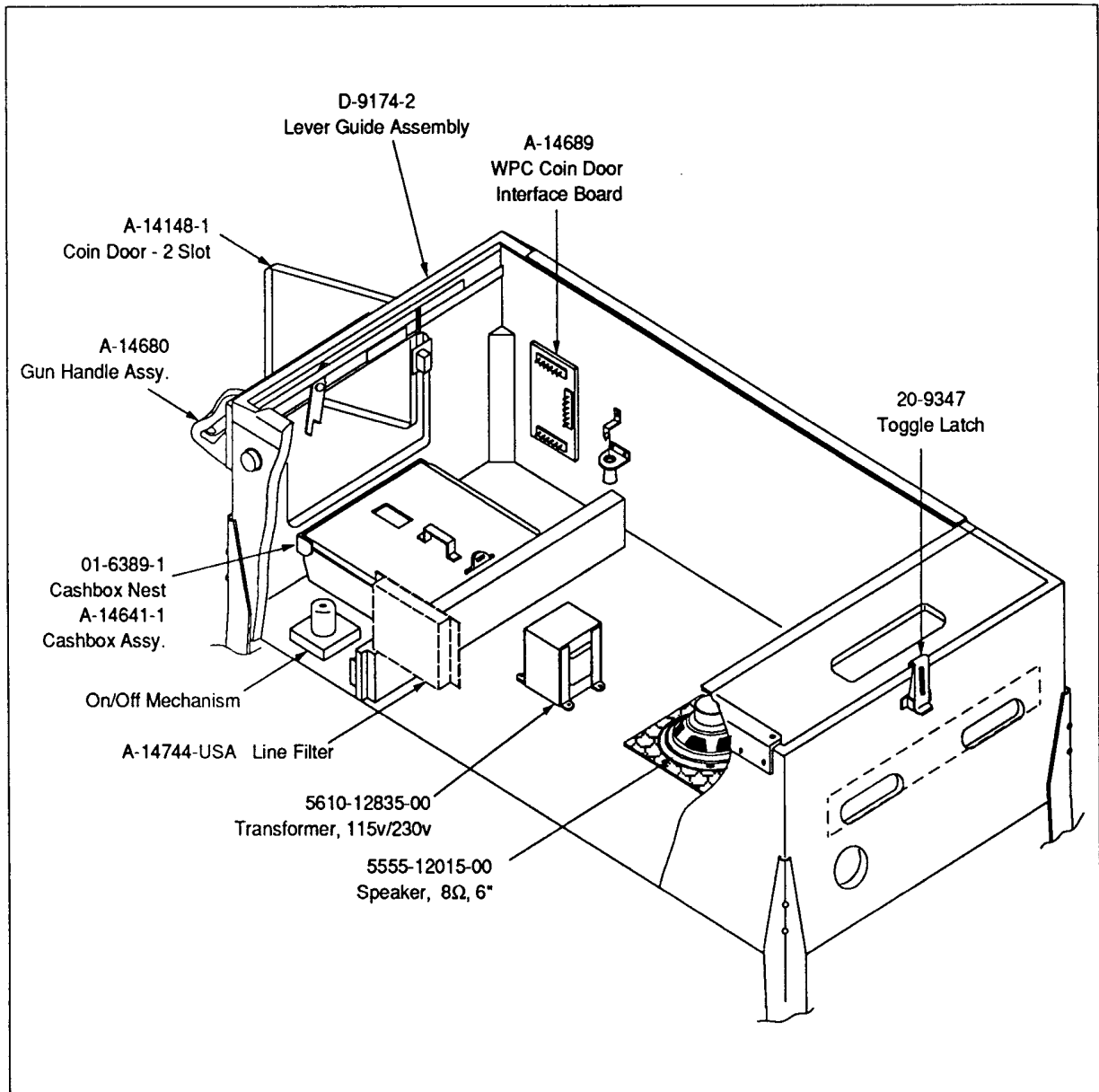

### ■ Miscellaneous Parts

Part Number	Description	Part Number	Description
A-14641-1	Cashbox Assembly	A-14754	Firing Pin Switch
A-8552-50013	Backglass Assembly	B-12273-5	Button Assembly - White
08-7028-T	Glass: 21 x 43"	C-10843	Metal Leg
31-1357-50013	Backglass: 27 x 18-7/8"	D-9174-2	Lever Guide Assembly
A-14680	Gun Handle Assembly	09-23002-1	Coin Door
A-14689	WPC Coin Door Interface	20-9347	Toggle Latch
5555-12015-00	Speaker, 8Ω, 6"	5610-12835-00	Transformer, 115/230v
A-14744-USA	Line Filter Assembly		

## Backbox Assembly

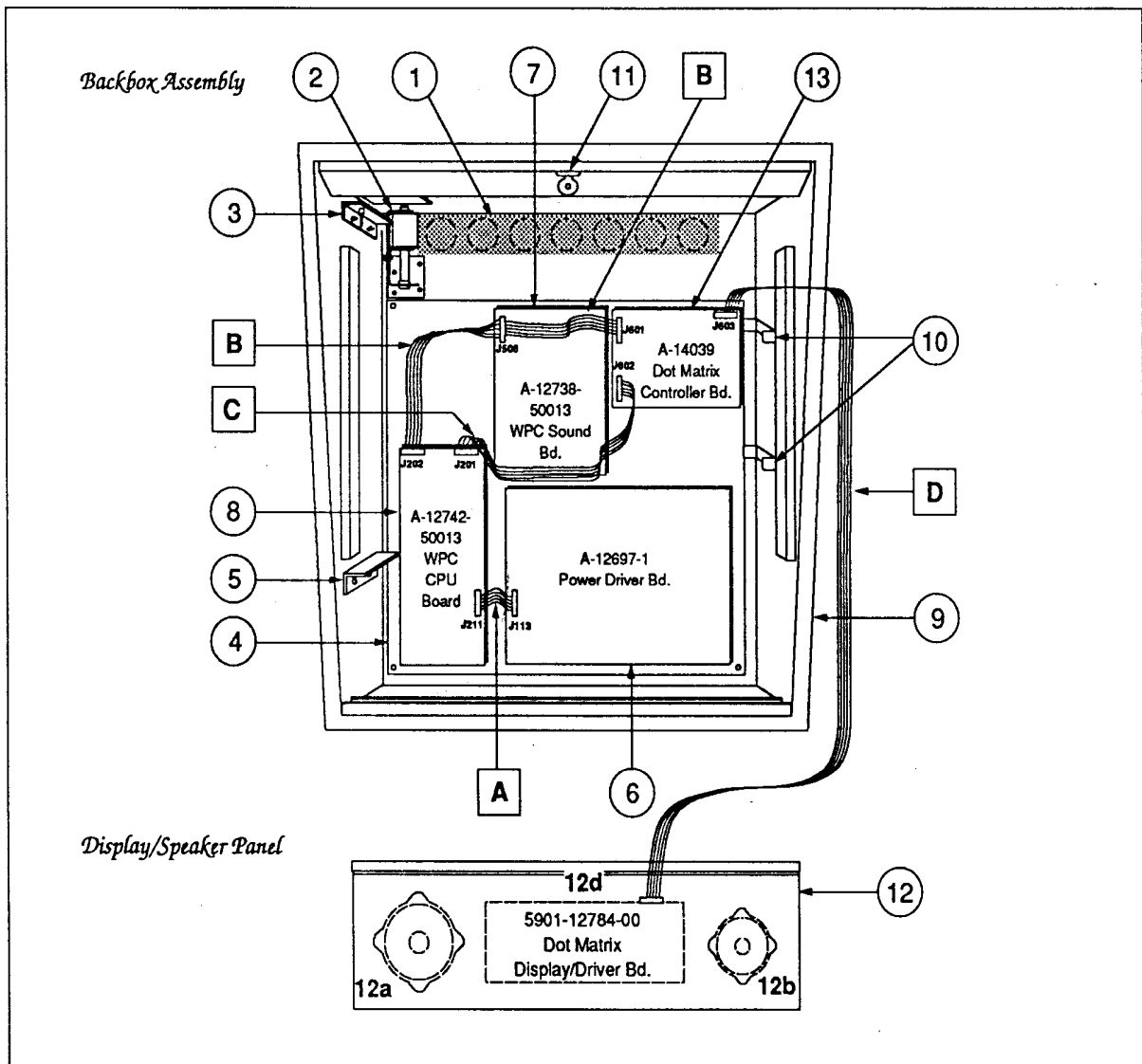

Item	Part Number	Description	Item	Part Number	Description
1.	01-6645	Venting Screen	12. c)	5045-12914-00	Capacitor, 10 $\mu$ fd., 50v, $\pm$ 20%
2.	B-10686-1*	Knocker & Bracket Assy.	d)	5901-12784-00	Dot Matrix Display/Driver Bd.
3.	A-12497	Upper Insert Bd Hinge Assy.	13.	A-14039*	Dot Matrix Controller Board
4.	A-14092-1	Mounting Plate Assembly	14.	50013-IN	Insert Board
5.	A-12498	Lower Insert Bd Hinge Assy.	a)	01-6571	Hinge Mounting Bracket
6.	A-12697-1*	Power Driver Assembly	b)	01-6655	Insert Latch
7.	A-12738-50013*	WPC Sound Board	<b>RIBBON CABLES:</b>		
8.	A-12742-50013*	WPC CPU Board	A.	5795-12653-03	Ribbon Cable, 3"
9.	A-14376-50013	Backbox Assembly	B.	5795-12837-01	Ribbon Cable, 36"
10.	01-9047	Insert Stop Bracket	C.	5795-10938-14	Ribbon Cable, 14"
11.	A-13379	Lock & Plate Assembly	D.	5795-12838-30	Ribbon Cable, 30"
a)	20-9637	Lock & Cam Kit			
12.	A-14457	Speaker / Display Assy.			
a)	5555-12856-00	Speaker, 5-1/4", 40 $\Omega$ , 25w			
b)	5555-12068-00	Speaker, 4" Piezo, 50w			

\* Refer to Individual Unit's Parts List

# Locations Diagram - Game Major Mechanisms

*Underside of Playfield, Viewed in Raised Position*

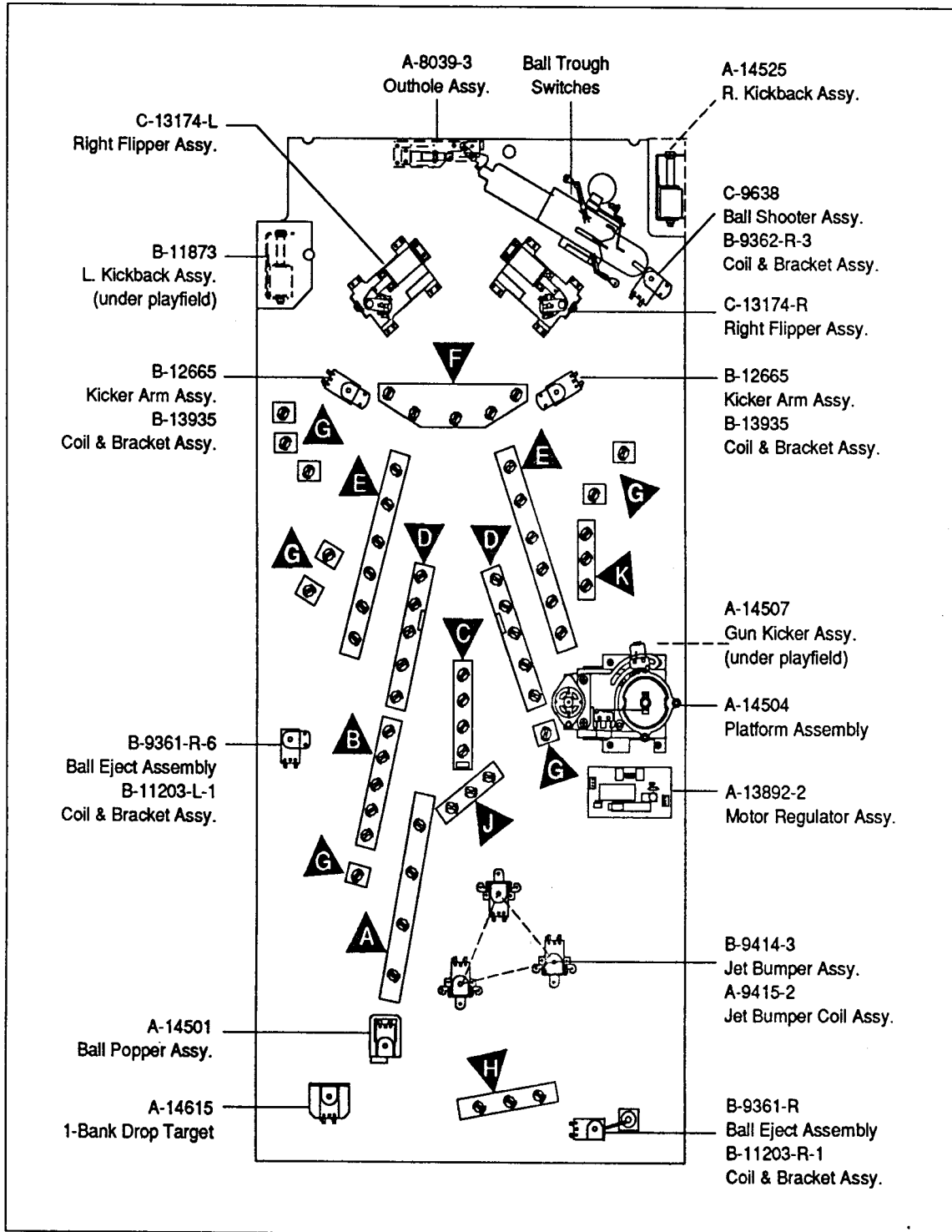

## ▲ Lamp Boards

Item	Part Number	Description
A	A-14516	4-Lamp Assembly
B	A-14517	5-Lamp Assembly
C	A-14518	G. I. Lamp Assembly
D	A-14519	5-Lamp Assembly
E	A-14520	6-Lamp Assembly

Item	Part Number	Description
F	A-14521	5-Lamp Assembly
G	B-12224	1-Lamp Assembly
H	C-12000	3-Lamp Assembly
J	C-12709	Lamp Target Assembly
K	C-13361	3-Lamp Assembly

# A-12738-50013 WPC Audio Board

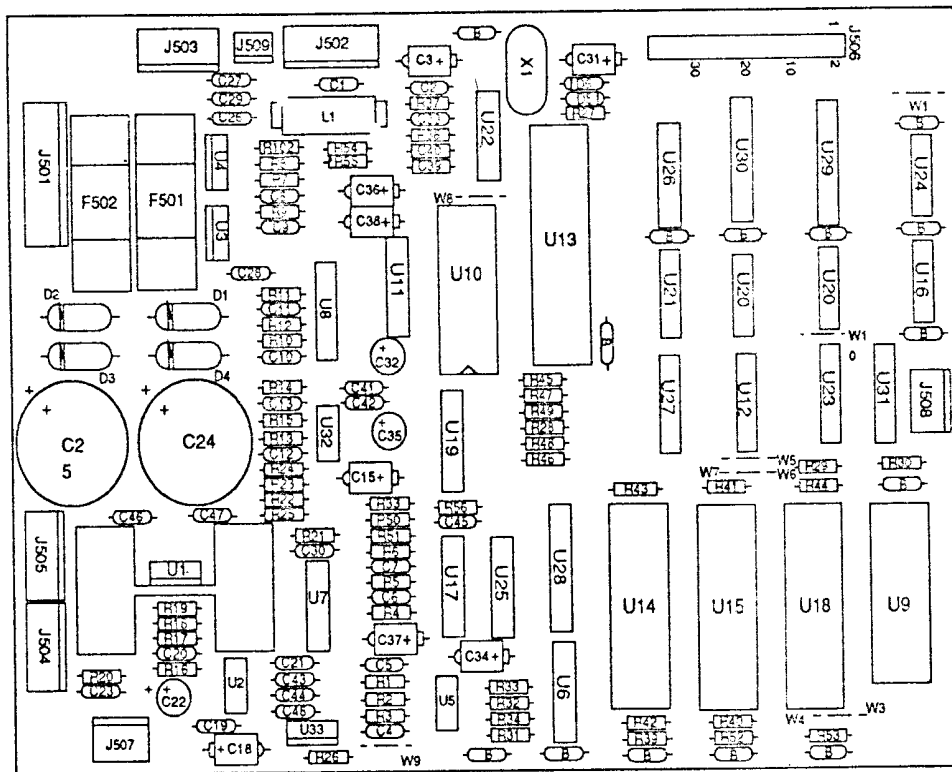

Part No.	Ckt Designator	Description	Part No.	Ckt Designator	Description
01-9980		Shield: Wire Protector	5048-12746-00	C5, C7	Capacitor, 330pfd., 50V
20-9229	U1	Thermal Compound	5048-12748-00	C9, C11, C30	Capacitor, 220pfd., 50V
4004-01005-06	U1	Mach. Screw, 4-40 x 3/8	5070-08919-00	D5, D6	Diode, 1N4148
4104-01012-04	U1	Sh. Mach. Screw, #4 x 1/4	5070-09045-00	D1-D4	Diode MR501, 3.0A.
4404-01119-00	U1	Nut, 4-40 SNUT	5250-10495-00	U3	Reg. 7912 1.0A -12v
5010-09324-00	R21	Resistor 27K $\Omega$ , 1/4w, 5%	5281-09215-00	U22	IC, 74LS04 Hex Inv
5010-12065-00	R22, R25	Resistor, 120K $\Omega$ , 1/4w, 5%	5281-09245-00	U12	IC, 74LS139 2-4 Dec.
5010-08991-00	R51	Resistor, 4.7K $\Omega$ , 1/4w, 5%	5281-09486-00	U28-U30	IC, 74LS374 8 Dual Flipflop
			5281-09487-00	U6, U23-U25	IC, 74LS74 Dual Flipflop
5010-09034-00	R13, R14, R29-R31, R33, R34, R50, R45-R49	Resistor, 10K $\Omega$ , 1/4w, 5%	5281-09500-00	U31	IC, 74LS32
			5281-09745-00	U26, U27	IC, 74LS138 DMultiplex
5010-09035-00	R4	Resistor, 47K $\Omega$ , 1/4w, 5%	5281-09850-00	U20	IC, 74LS11 Trippole AND
5010-09036-00	R35	Resistor, 100K $\Omega$ , 1/4w, 5%	5281-10577-00	U16	IC, 74LS125 C/B Bif
5010-09134-00	R1, R2, R6, R8, R9, R11, R12, R23, R24	Resistor, 150K $\Omega$ , 1/4w, 5%	5370-11086-00	U10	IC, YM2151 Sound
			5371-11087-00	U11	IC, YM3012 D/A
5010-09162-00	R25, R102	Resistor, 100K $\Omega$ , 1/4w, 5%	5400-10320-00	U13	IC, MPU 68B09E
5010-08774-00	R3, R5, R17, R19	Resistor, 22K $\Omega$ , 1/4w, 5%	5284-12651-00	U21	IC 4564
5010-09269-00	R15	Resistor, 12K $\Omega$ , 1/4w, 5%	5340-12278-00	U9	SRam 2054
5010-09358-00	R18, R32	Resistor, 1K $\Omega$ , 1/4w, 5%	5370-09691-00	U17	IC, 55536 CVSD
5010-09416-00	R28, R39, R40-R44	Resistor, 470 $\Omega$ , 1/4w, 5%	5370-12260-00	U2	IC, 3340 Elec Atten
			5370-12728-00	U1	IC, Audio Amp LM1875
5010-09534-00	R52, R53, R57, R36, R37	Resistor, 0 $\Omega$	5370-12730-00	U7, U8	IC, Op Amp TL084
5010-10171-00	R38, R56	Resistor, 56 $\Omega$ , 1/4w, 5%	5370-12742-00	U32	IC, Op Amp TL082
5010-10258-00	R16	Resistor, 1M $\Omega$ , 1/4w, 5%	5371-12727-00	U19	Dac AD7524
5010-10650-00	R7, R10	Resistor, 62K $\Omega$ , 1/4w, 5%	5432-12726-00	U5	EE Prom Pot X9503
5010-10989-00	R54, R55, R27	Resistor, 470K $\Omega$ , 1/4w, 5%	5460-12423-00	U4	IC, LM7812
5010-12752-00	R20	Resistor, 1 $\Omega$ , 1/4w, 5%	5460-12743-00	U33	LM7809 TO-220
5040-08986-00	C3	Capacitor, 100M, 10v ( $\pm$ 20%)	5520-09020-00	X1	Crystal, 3.58 MHz.
5040-09332-00	C15, C18, C34, C36, C38	Capacitor, 47 $\mu$ fd., 25v, Axial	5521-10531-00	OSC1	Oscillator, 8.0 MHz.
			5551-09822-00	L1	Ind, 4.7UH 3.0A.
5040-11036-00	C32, C35	Capacitor, 47 $\mu$ fd., 16v, Rad.	5700-08985-00	U13	Socket, IC 40-pin, .6"
5040-12729-00	C24, C25	Capacitor, 4700 $\mu$ fd., 35v	5700-09004-00	U10	Socket, IC 24-pin, .6"
5040-12750-00	C22	Capacitor, 22 $\mu$ fd., 35v, Rad.	5700-09006-00	U11	Socket, IC 16-pin, .3"
5041-09031-00	C26-C29, C37, C46-C48	Capacitor, 1 $\mu$ fd. TANT	A-5343-50013-4	U18	IC, Audio ROM
5041-09243-00	C20, C21	Capacitor, 10 $\mu$ fd. TANT	A-5343-50013-3	U15	IC, Audio ROM
5043-08980-00	C41-C44, B(15)	Capacitor, .01M, 50v, (+80, -20)	A-5343-50013-2	U14	IC, Audio ROM
5043-08996-00	C1, C2	Capacitor, .1 $\mu$ fd., 50v, 10%	5700-12088-00		Socket, IC 32-pin (U14, U15, U18)
5048-11027-00	C8, C10	Capacitor, 33pfd., 50v, 10%	5705-12755-00	U1	Heatsink 52993-220
5048-11028-00	C45	Capacitor, 22pfd., 50V, Axial	5731-08633-00	F501, F502	Fuse, 3A, S-B
5048-11029-00	C33, C49	Capacitor, 100pfd., 50v	5733-12060-01		Fuse Holder (F501, F502)
5048-11030-00	C12	Capacitor, 470pfd., 50v	5766-12433-00		PCB-Sound 90
5048-11031-00	C19, C31	Capacitor, .001 $\mu$ fd., 50v, 10%	5791-10862-04	J504, J505	Connector, 4-pin Header Sq. .156
5048-11065-00	C13	Capacitor, .0022 $\mu$ fd., 50v, 10%, Ax.	5791-10862-05	J502	Connector, 5-pin Header Sq. .156
5048-11072-00	C39, C40	Capacitor, .0033 $\mu$ fd.	5791-10862-07	J501	Connector, 7-pin Header Sq. .156
5048-12036-00	C23	Capacitor, 22 $\mu$ fd., 10v, Ceramic	5791-12462-03	J503	Connector, 3-pin Header Sq. .100
5048-12745-00	C4, C6	Capacitor, 1800pfd., 50V, 10%	5791-12462-04	J508	Connector, 4-pin Header Sq. .100
16-8850-341		PCB Label	5791-12516-00	J506	34 Hen 2x17 STR

## A-12742-50013 WPC CPU Board

Item	Part Number	Ckt Designator	Description
1	5010-09034-00	R14-R22, R27-R42, R86, R90, R94, R98	Resistor, 10K $\Omega$ , 1/4w, 5%
2	5010-09085-00	R1, R2, R4, R93, R96, R97	Resistor, 1.5K $\Omega$ , 1/4w, 5%
3	5010-09314-00	R52, R54, R56, R58, R60, R62, R64, R66, R75-R82	Resistor, 1.2K $\Omega$ , 1/4w, 5%
4	5010-09358-00	R3, R43-R51, R53, R55, R57, R59, R61, R63, R65, R67-R74, R84	Resistor, 1K $\Omega$ , 1/4w, 5%
5	5010-09416-00	R5-R8, R12, R13, R87-R89	Resistor, 470 $\Omega$ , 1/4w, 5%
6	5010-09534-00	W1, W4, W7, W13 - W18	Resistor, 0 $\Omega$
7	5010-10258-00	R95, R99	Resistor, .01 $\mu$ fd $\Omega$ , 1/4w, 5%
8	5010-10989-00	R92	Resistor, 470K $\Omega$ , 1/4w, 5%
9	5010-12104-00	R91	Resistor, 22 $\mu$ fd, 1/4w, 5%
10	5019-09362-00	SIP 1	SIP, 9R, 10-pin, 4.7K $\Omega$ , 5%
11	5040-08986-00	C31	Capacitor, 100 $\mu$ fd, 10v ( $\pm$ 20%)
12	5043-08980-00	B	Capacitor, .01 $\mu$ fd, 50v, (+80, -20%)
13	5043-09030-00	C27	Capacitor, 0.047 $\mu$ fd, 50v ( $\pm$ 20%)
14	5043-09065-00	C3 - C26	Capacitor, 470pfd, 50v ( $\pm$ 20%)
15	5043-09491-00	C2, C29, C30, C34	Capacitor, 22pfd, 1KV, ( $\pm$ 10%)
16	5043-09492-00	C28	Capacitor, 100pfd, 50v, ( $\pm$ 10%)
17	5043-09845-00	C32, C33	Capacitor, 1KP, 50v, ( $\pm$ 20%)
18	5070-08919-00	D2 - D18	Diode, 1N4148, 150MA
19	5070-09266-00	D1, D25	Diode, 1N5817, 1.0A.
20	5160-10269-00	Q1	Transistor, 2N3904, NPN
21	5162-12422-00	U20	IC, ULN, 2803A
22	5281-09308-00	U3	IC, 74LS245, Octal Bus Trncv
23	5281-09486-00	U14	IC, 74LS374, 8D F/F
24	5281-09851-00	U5	IC, 74LS14, SMT/TRG
25	5281-09867-00	U1, U2, U7	IC, Octal Buffer, 74LS244
26	5281-10182-00	U11, U12, U13, U15	IC, 74LS240 Driver
27	5284-12651-00	U21	IC, 4584
28	5340-12278-00	U8	S/RAM 2064
29	5370-12272-00	U16 - U19	IC, LM339, Quad. Comp
30	5370-12687-00	U10	MC, 34064 Reset Chip
31	5520-10438-00	X2	Crystal, 8.0MHz.
32	5520-12084-00	X1	Crystal 32.768 KHz
33	5551-09822-00	L1	ILN, 4.7 UH 3A
34	5671-09019-00	D19 - D21	DSPL LED RED
35	5700-08985-00	U4	Socket, IC 40P, .6"
36	5700-12088-00	U6	Socket, IC 32P, .6"
37	5700-12424-00	U9	Socket, 84 Pin PLCC
38	5764-12431-00		PC Board
39	5791-10850-00	J201, J204	Connector, 26-pin Header Str Sq.
40	5791-10862-07	J210	Connector, 7-pin Header Str Sq.
41	5791-12461-08	J212	Connector, 8-pin Header Str Sq.
42	5791-12461-09	J206 - J209	Connector, 9-pin Header Sq. pin
43	5791-12461-12	J205	Connector, 12-pin Header Sq. pin
44	5791-12516-00	J202, J211	34 Hen 2x17 STR
45	5881-09021-00	B1 - B3	Battery Holder "AA"
46	5048-11033-00	C50	Capacitor, 0.022 $\mu$ f, 10v
47	16-8850-350		PCB Label
48	A-5343-50013-1	U6	Game PROM Assembly
49	5410-12426-00	U9	WPC-89 ASIC
50	5400-10320-00	U4	IC MPU 68B09E
51	5880-09022-00	B1 - B3	Battery, Alkaline, 1.5v ("AA")



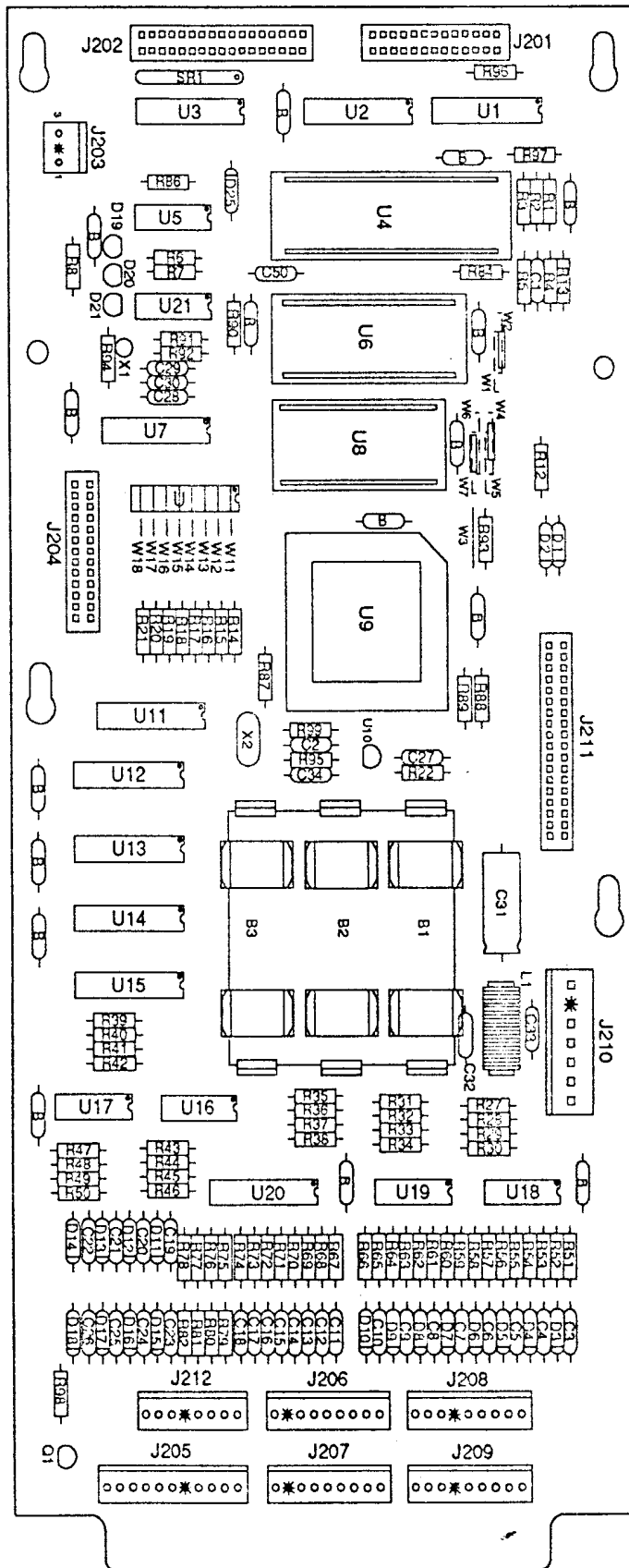

# A-12697-1 WPC Power Driver Assembly

Item	Part Number	Ckt Designator	Description	Item	Part Number	Ckt Designator	Description
1	20-9229	Q2, Q10, Q12, Q14, Q16, Q18	Thermal Compound	41	5194-09055-00	Q9, Q11, Q13, Q15, Q17, Q19, Q21, Q23, Q25, Q27, Q29, Q31, Q33, Q35, Q37, Q39, Q41, Q43, Q45, Q47, Q49, Q51, Q53, Q55, Q57, Q59-Q62, Q71-Q74, Q99	Transistor, 2N4403 PNP
2	4006-01005-06	Q1, Q2	Mach. Screw, 6-32 x 3/8	42	5191-12179-00	Q64, Q66, Q68, Q70, Q76 Q78, Q80, Q82	Transistor, TIP36C PNP
3	4406-01128-00	Q1, Q2	Nut, 6-32 KEPS	43	5192-12428-00	Q91-Q98	Transistor, TIP 107
4	4004-01005-06	Q10, Q12, Q14, Q16, Q18	Mach. Screw, 4-40 x 3/8	44	5250-12634-00	Q1	Reg LM 323 5v
5	4404-01119-00	Q10, Q12, Q14, Q16, Q18	Nut, 4-40 SNUT	45	5281-09486-00	U1-U5, U18	IC, 74LS374 8 Dual D Flipflop
6	5010-08981-00	R260	Resistor, 10K $\Omega$ , 1/2w, 5%	46	5281-09487-00	U10-U13	IC, 74LS74 Dual D flipflop
7	5010-08991-00	R9, R12, R15, R18, R21, R23, R27, R31, R35, R39, R43, R47, R51, R55, R59, R63, R67, R71, R75, R79, R83, R87, R91, R95, R99, R126, R128, R130, R132, R134, R136, R138, R140, R209, R227	Resistor, 4.7K $\Omega$ , 1/4w, 5%	47	5281-10182-00	U9	IC, 74LS240, L/Drvr
8	5010-08992-00	R8, R11, R14, R17, R20, R177, R179, R181, R183, R185, R187, R189, R191, R208	Resistor, 560 $\Omega$ , 1/4w, 5%	48	5370-12272-00	U6, U15, U16	IC, LM339 Quad. Comp
9	5010-08993-00	R25, R29, R33, R37, R41, R45, R49, R53, R57, R61, R65, R69, R73, R77, R81, R85, R89, R93, R97, R101, R103, R106, R109, R112, R115, R118, R121, R124, R24, R28, R32, R36, R40, R44, R48, R52, R56, R60, R64, R68, R72, R76, R80, R84, R88, R92, R96, R100, R102, R105, R108, R111, R114, R117, R120, R123, R195	Resistor, 68 $\Omega$ , 1/4w, 5%	49	5460-12423-00	Q2	IC, LM 7812
10	5010-08997-00	R155, R157, R159, R161, R165, R167, R169, R171, R3, R4, R6, R142-R149, R197-R198	Resistor, 2.7K $\Omega$ , 1/4w, 5%	50	5490-10892-00	U7, U8	Opto Isolator, 4N25
11	5010-08998-00	R194, R196, R251, R253-R257	Resistor, 2.2K $\Omega$ , 1/4w, 5%	51	5580-08994-01	RLY 1	Relay 4PDT 6VDC5A VS
12	5010-09034-00	R252	Resistor, 10K $\Omega$ , 1/4w, 5%	52	5671-09019-00	LED1 - LED7	Display LED Red
13	5010-09085-00	R1, R2, R192, R201- R205	Resistor, 1.5K $\Omega$ , 1/4w, 5%	53	5701-09652-00	Q1	Thermal Pad TO-3
14	5010-09086-00	R176, R178, R180, R182, R184, R186, R188, R190, R206	Resistor, 6.8K $\Omega$ , 1/4w, 5%	54	5705-09199-00	Q2	Heatsink, #6030B
15	5010-09224-00	R184, R186, R188, R190, R206	Resistor, 270 $\Omega$ , 1/4w, 5%	55	A-13944	Bridge Assembly	WPC Heatsink Rectifier Assy
16	5010-09314-00	R154, R156, R158, R160, R164, R166, R168, R170, R182, R193, R199, R200, R250	Resistor, 1.2K $\Omega$ , 1/4w, 5%	56	5705-12637-00	Q1	Heatsink 5054
17	5010-09324-00	R104, R107, R110, R113, R116, R119, R122, R125, R22, R26, R30, R34, R38, R42, R46, R50, R54, R58, R62, R66, R70, R74, R78, R82, R86, R90, R94, R98, R127, R129, R131, R133, R135, R137, R139, R141	Resistor, 27K $\Omega$ , 1/4w, 5%	57	5705-12638-00	Q10, Q12, Q14, Q16, Q18	Heatsink 5298B
18	50 J-09358-00	R154, R156, R158, R160, R164, R166, R168, R170, R182, R193, R199, R200, R250	Resistor, 1K $\Omega$ , 1/4w, 5%	58	5733-12060-01		Fuse Holder, F101-F116
19	5010-09361-00	R104, R107, R110, R113, R116, R119, R122, R125, R22, R26, R30, R34, R38, R42, R46, R50, R54, R58, R62, R66, R70, R74, R78, R82, R86, R90, R94, R98, R127, R129, R131, R133, R135, R137, R139, R141	Resistor, 220 $\Omega$ , 1/4w, 5%	59	5763-12405-00		Bare PCB
20	5010-09416-00	R104, R107, R110, R113, R116, R119, R122, R125, R22, R26, R30, R34, R38, R42, R46, R50, R54, R58, R62, R66, R70, R74, R78, R82, R86, R90, R94, R98, R127, R129, R131, R133, R135, R137, R139, R141	Resistor, 470 $\Omega$ , 1/4w, 5%	60	5791-10862-03	J108, J119, J136	Connector, 3-pin Header STR Sq.
21	5010-09534-00	W1, W2	Resistor, 0 $\Omega$	61	5791-10862-04	J103, J116-J118	Connector, 4-pin Header STR Sq.
22	5010-11079-00	R7, R10, R13, R16, R19	Resistor, 51 $\Omega$ , 1/4w, 5%	62	5791-10862-05	J112, J104-J106, J123, J124, J128, J129, J131, J132, J105	Connector, 5-pin Header STR Sq.
23	5010-12427-00	R150-R153, R172-R175	Resistor, .22 $\Omega$ , 1w, 5%	63	5791-10862-06	J107	Connector, 6-pin Header STR Sq.
24	5012-12632-00	R224	Resistor, .12 $\Omega$ , 10w, 5%	64	5791-10862-07	J101, J109, J114	Connector, 7-pin Header STR Sq.
25	5012-12238-00	R210, R211	Resistor, 3.3K $\Omega$ , 5w, 10%	65	5791-10862-09	J102, J110, J122, J125, J127, J130, J137, J138	Connector, 9-pin Header STR Sq.
26	5019-10143-00	SR1	SIP, 9R, 10 pin, 470 $\Omega$ , 5%	66	5791-10862-11	J120, J121	Connector, 11-pin Header STR Sq.
27	5040-08986-00	C4	Capacitor, 100 $\mu$ fd, 10v ( $\pm$ 20%)	67	5791-10862-12	J115	Connector, 12-pin Header STR Sq.
28	5040-09421-00	C2	Capacitor, 100 $\mu$ fd, 25v (+50, -10%)	68	5791-10862-13	J126	Connector, 13-pin Header STR Sq.
29	5040-09537-00	C8	Capacitor, 100 $\mu$ fd, 100v ( $\pm$ 20%)	69	5791-12461-05	J111	Connector, 5-pin Header STR Sq.
30	5040-12313-00	C5, C6, C7, C11, C30	Capacitor, 15,000 $\mu$ fd, 25v ( $\pm$ 20%)	70	5791-12461-09	J133-J135	Connector, 9-pin Header STR Sq.
31	5043-08980-00	B-BYPASS	Capacitor, .01 $\mu$ fd, 50v (+80, -20%)	71	5791-12516-00	J113	34 HEN 2x17 STR
32	5043-08996-00	C13-C20, C31	Capacitor, .1 $\mu$ fd, 50v ( $\pm$ 20%)	72	5824-09248-00	TP1-TP8	Test Point #1502-1
33	5043-09845-00	C1, C12	Capacitor, 1,000 $\mu$ fd, 50v ( $\pm$ 20%)	73	5041-09163-00	C9	Capacitor, 2.2 $\mu$ fd TANT
34	5048-10994-00	C3	Capacitor, .33 $\mu$ fd, 50v ( $\pm$ 20%) Ax.	74-100	Not Used		ID Label
35	5070-08919-00	D33, D34	Diode, 1N4148, 150MA.	101	16-8850-323		Fuse, 8A, 32v
36	5070-09054-00	D1-D3, D5-D12, D17-D32, D38, D39	Diode, 1N4004, 1.0A.	102	5730-09071-00	F114	Fuse, S-B, 2.5A., 250v
37	5100-09690-00	BR3-BR5	Bridge Rectifier, 35A., 200v	103	5731-09128-00	F101, F102	Fuse, S-B, 5A., 250v
38	5131-12725-00	Q10, Q12, Q14, Q16, Q18	Triac, BT138E	104	Not Used		Fuse, S-B, 5A., 250v
39	5162-12422-00	U19	IC, ULN 2803	105	5731-09651-00	F106-F113	Fuse, S-B, 3A., 250v
40	5162-12635-00	Q20, Q22, Q24, Q26, Q28, Q30, Q32, Q34, Q36, Q38, Q40, Q42, Q44, Q46, Q48, Q50, Q52, Q54, Q56, Q58, Q63, Q65, Q67, Q69, Q75, Q77, Q79, Q81, Q83 - Q90	Transistor, TIP 102	106	Not Used		Fuse, S-B, 3/4A., 250v

**NOTE:**

For schematic refer to drawing #16-9057.

# A-12697-1 WPC Power Driver Board

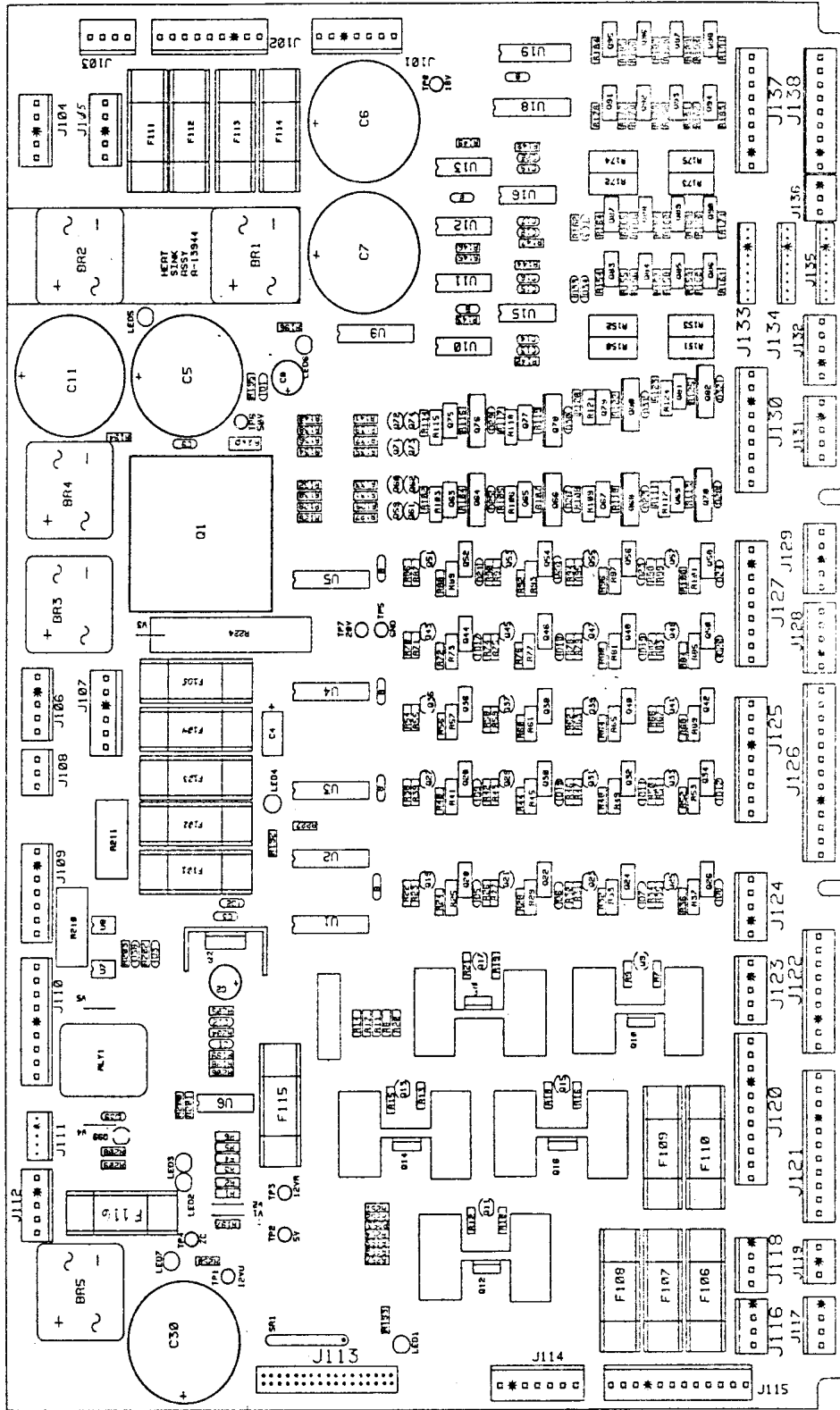

## A-14039 Dot Matrix Controller Assembly

Item	Part Number	Ckt Designator	Description
1	5010-08991-00	R1	Resistor, 4.7K $\Omega$ , 1/4w, 5%
2	5010-09224-00	R10	Resistor, 270 $\Omega$ , 1/4w, 5%
3	5010-09534-00	R7	Resistor, 0 $\Omega$
4	5010-12832-00	R3, R6, R12, R13	Resistor, 47K $\Omega$ , 1/2w, 5%
5	5010-12841-00	R4, R5	Resistor, 120 $\Omega$ , 1/2w, 5%
6	5012-12830-00	R9	Resistor, 1.8K $\Omega$ , 5w, 5%
7	5012-12842-00	R11	Resistor, 120 $\Omega$ , 5w, 5%
8	5012-12843-00	R8	Resistor, 4.7K, 5w, 5%
9	5040-08986-00	C3	Capacitor, 100 $\mu$ fd., 10v, ( $\pm$ 20%)
10	5040-12324-00	C4, C7	Capacitor, 150 $\mu$ fd., 160v, ( $\pm$ 50%)
11	5043-08980-00	BYPASS	Capacitor, .01 $\mu$ fd., 50v, (+80, -20%)
12	5043-09072-00	C6, C9, C10	Capacitor, .1 $\mu$ fd., 500v, (+80, -20%)
13	5043-09845-00	C1, C2, C11	Capacitor, 1KP, 50v, ( $\pm$ 20%)
14	5070-09054-00	D7	Diode, 1N4004, 1.0A.
15	5075-12824-00	D6, D8	Zener, 1N4742A, 12v
16	5075-12823-00	D3 - D5	Zener, 1N4758A, 62v
17	5100-12833-00	BR1, BR2	Bridge, 400v, 1A.
18	5160-10269-00	Q1	Transistor, 2N3904 NPN
19	5164-09056-00	Q2, Q10	Transistor, MP5D02, NPN
20	5164-12154-00	Q3, Q7	Transistor, MJE15030 NPN
21	5194-09055-00	Q4, Q5	Transistor, MP5D52 PNP
22	5194-12155-00	Q6	Transistor, MJE15031 PNP
23	5281-09738-00	U16, U25 - U27	IC, 74LS157
24	5281-10033-00	U3	IC, 74LS30
25	5281-10043-00	U31 - U33, U35	IC, 74LS175
26	5311-10946-00	U4, U5, U17, U18, U20	IC, 74HC74
27	5311-10947-00	U9	IC, 74HC125
28	5311-10951-00	U10, U11	IC, 74HC161
29	5311-10977-00	U6	IC, 74HC04
30	5311-12817-00	U29	IC, 74HC165
31	5311-12819-00	U21	IC, 74HC688
32	5311-12820-00	U23	IC, 74HC27
33	5311-12822-00	U13 - U15	IC, 74HC193
34	5315-12009-00	U22	IC, 74HCT374
35	5315-12812-00	U1, U2, U30	IC, 74HCT138
36	5281-09308-00	U28	IC, 74HCT245
37	5315-12815-00	U8, U34	IC, 74HCT08
38	5315-12816-00	U19	IC, 74HCT32
39	5315-12821-00	U7	IC, 74HCT240
40	5340-12278-00	U24	S/RAM 2064 150NS
41	5551-09822-00	L1	IND 4.7 $\mu$ H, 3.0A.
42	5671-09019-00	D10	Display LED Red
43	5705-09199-00	Q3, Q6, Q7	Heatsink 6030B
44	5731-12328-00	F601, F602	Fuse, 3/8A., SB, 250v
45	5733-12060-00		Fuse Holder (F601, F602)
46	5760-12710-00		PC Board
47	5791-10850-00	J602	Connector, 26-pin STR Sq.
48	5791-10862-05	J605	Connector, 5-pin Header Sq.
49	5791-10862-07	J606	Connector, 7-pin Header Sq.
50	5791-10862-08	J604	Connector, 8-pin Header Sq.
51	5791-12516-00	J601	34 Hen 17x2 STR
52	5791-12827-00	J603	14 Hen 7x2 STR
53	5010-09036-00	R14-R23	Resistor, 100 $\Omega$ , 1/4w, 5%
54	20-9229	Q3, Q6, Q7	Thermal Compound
55	4006-01003-06	Q3, Q6, Q7	Mach. Screw, 6-32 x 3/8
56	4406-01128-00	Q3, Q6, Q7	Nut, 6-32 KEPS
57	5043-09492-00	C5, C8	Capacitor, 100P, 50v, ( $\pm$ 10%)
58	5010-10171-00	R7	Resistor, 56 $\Omega$ , 1/4w, 5%

\* Refer to Schematic #16-9148.

# A-14039 Dot Matrix Controller Assembly

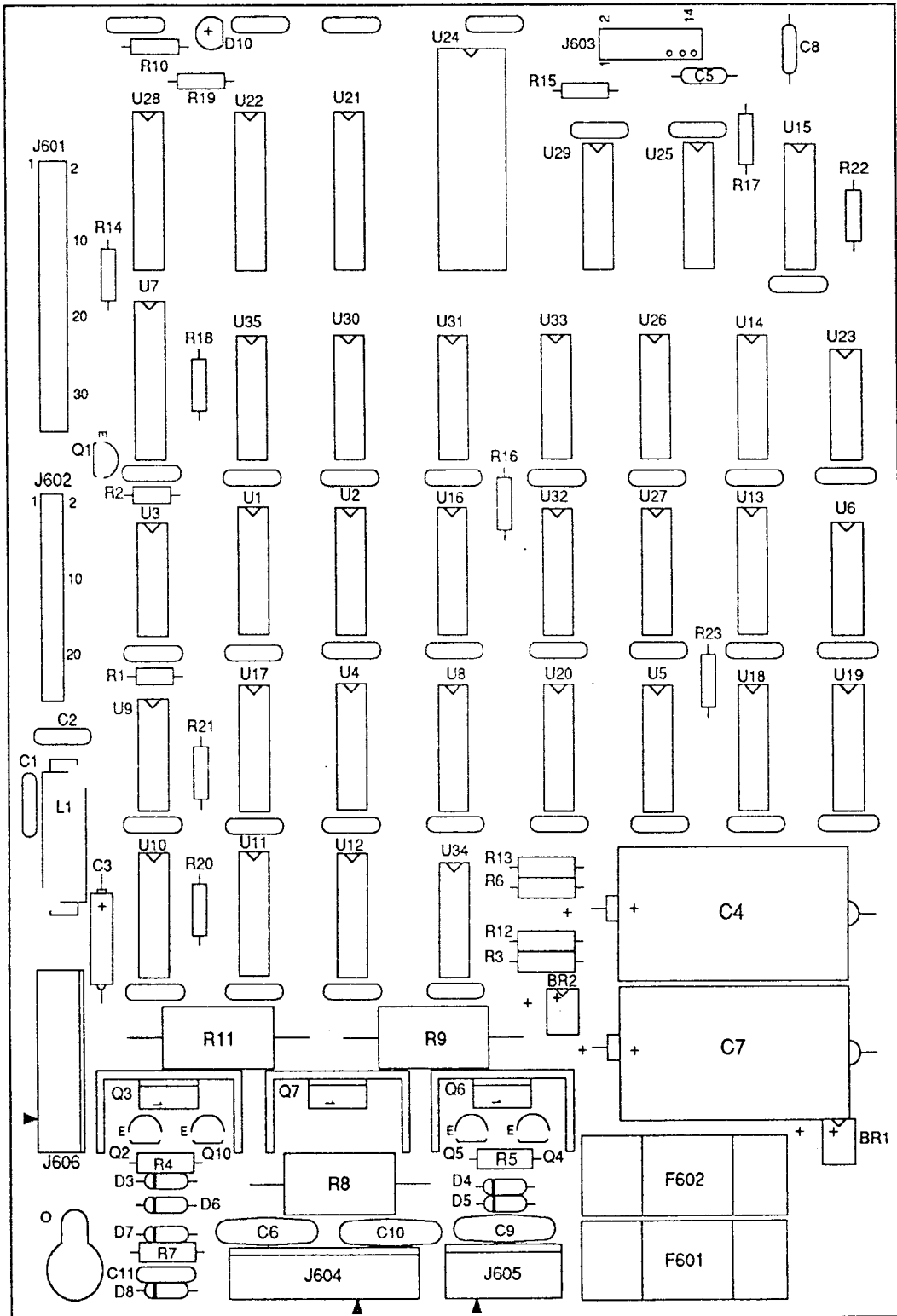

### A-13892-2 Motor Regulator Assembly

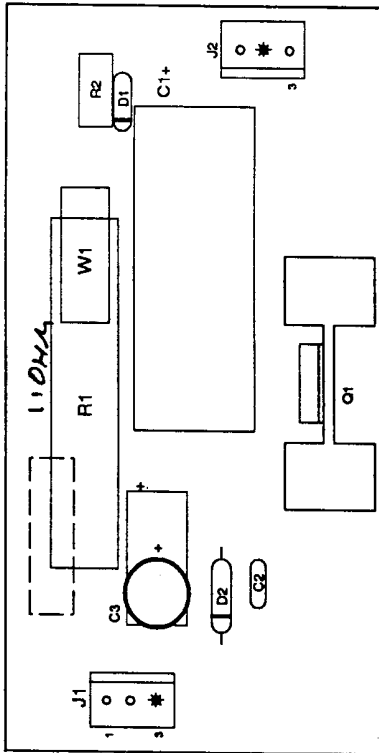

Part Number	Designator	Description
5040-12466-00	C1	Capacitor, 1000μfd, 50v, Axial
5043-08996-00	C2	Capacitor, .1μfd, 50v, Axial
5040-10974-00	C3	Capacitor, 100μfd, 35v, Radial
5070-09054-00	D1	Diode, 1N4004, 1.0A.
5075-12467-00	D2	Zener, Diode 1N5243B, 13V.
5791-12273-03	J1, J2	Connector, 3-pin Header
5162-12635-00	Q1	Trans. NPN Darl TIP 102
5012-12468-00	R1	Resistor, 30Ω, 10w, 10%
5010-09061-00	R2	Resistor, 680Ω, 1/2w, 5%
5705-12464-00		Heatsink
4004-01005-06		Mach. Screw, 4-40 x 3/8
4404-01117-00		Nut, 4-40 Hex.
4703-00015-00		Flatwasher External, #4
20-9229		Thermal Compound
5010-09534-00	W1	Resistor, 0Ω
5768-12685-00		PCB Motor Regulator
16-8850-352		Label

### A-14689 WPC Coin Door Interface Board

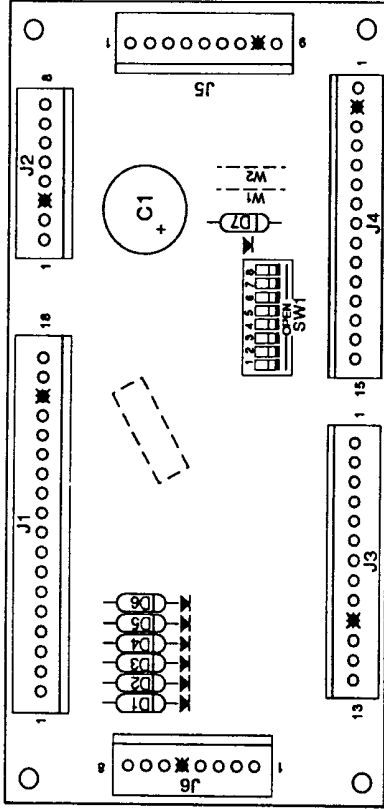

Part Number	Designator	Description
5768-12855-00		WPC Bare PC Board
5070-09054-00	D1-D7	Diode, 1N4004, 1.0A.
5791-10862-18	J1	Connector, 18-pin Header Str Sq.
5791-10862-08	J2, J6	Connector, 8-pin Header Str Sq.
5791-10862-13	J3	Connector, 13-pin Header Str Sq.
16-8850-355		I.D. Label

**Notes:**  
 1. For Belgium, France and England use A-14102-1 Coin Door Interface Board.  
 2. For schematic refer to drawing #16-9152.

## Lamp Boards

### B-12224-1 Single Lamp Board

Part Number	Description
5768-12312-00	Lamp PCB
24-8767	Twist Lamp Socket
24-8768	Bulb #555, (6.3v, 0.25A.)
5010-09534-00	Resistor, 0Ω

### A-14516 4-Lamp Board

Part Number	Description
5768-12789-00	Lamp PCB
24-8767	Twist Lamp Socket
24-8768	Bulb #555, (6.3v, 0.25A.)
5070-09054-00	Diode, 1N40004
5791-10871-06	Connector, 6-pin Header Sq Flat

### A-14517 5-Lamp Board

Part Number	Description
5768-12790-00	Lamp PCB
24-8767	Twist Lamp Socket
24-8768	Bulb #555, (6.3v, 0.25A.)
5070-09054-00	Diode, 1N40004
5791-10871-07	Connector, 7-pin Header Sq Flat

### A-14518 Gen. Illum. Lamp Board

Part Number	Description
5768-12791-00	Lamp PCB
24-8767	Twist Lamp Socket
24-8768	Bulb #555, (6.3v, 0.25A.)
5791-10871-04	Connector, 4-pin Header Sq Flat

### A-14519 5-Lamp Board

Part Number	Description
5768-12792-00	Lamp PCB
24-8767	Twist Lamp Socket
24-8768	Bulb #555, (6.3v, 0.25A.)
5070-09054-00	Diode, 1N40004
5791-10871-07	Connector, 7-pin Header Sq Flat

### A-14520 6-Lamp Board

Part Number	Description
5768-12793-00	Lamp PCB
24-8767	Twist Lamp Socket
24-8768	Bulb #555, (6.3v, 0.25A.)
5070-09054-00	Diode, 1N40004
5791-10871-08	Connector, 8-pin Header Sq Flat

### A-14521 5-Lamp Board

Part Number	Description
5768-12794-00	Lamp PCB
24-8767	Twist Lamp Socket
24-8768	Bulb #555, (6.3v, 0.25A.)
5070-09054-00	Diode, 1N40004
5791-10871-07	Connector, 7-pin Header Sq Flat

### C-12709 Lamp Target Board

Part Number	Description
5768-12409-00	Lamp PCB
24-8767	Twist Lamp Socket
24-8768	Bulb #555, (6.3v, 0.25A.)
5070-09054-00	Diode, 1N40004
5791-10871-05	Connector, 5-pin Header Sq Flat

### C-12000 3-Lamp Board

Part Number	Description
5768-12245-00	Lamp PCB
24-8767	Twist Lamp Socket
24-8768	Bulb #555, (6.3v, 0.25A.)
5070-09054-00	Diode, 1N40004
5791-10871-05	Connector, 5-pin Header Sq Flat

### C-13361 3-Lamp Board

Part Number	Description
5768-12584-00	Lamp PCB
24-8767	Twist Lamp Socket
24-8768	Bulb #555, (6.3v, 0.25A.)
5070-09054-00	Diode, 1N40004
5791-10871-05	Connector, 5-pin Header Sq Flat

**C-13174-R**  
**C-13174-L**

**Flipper Assembly (Right)**  
**Flipper Assembly (Left)**

Item	Part Number	Description	Item	Part Number	Description
1.	B-13104-R	Flipper Base Assy, Right	21.	B-10655-R	Crank Link Assembly, Right
*	B-13104-L	Flipper Base Assy, Left	*	B-10655-L	Crank Link Assembly, Left
2.	03-7811 <del>WNS073</del>	End of Stroke (EOS) Sw.	a)	02-4179	Link Spacer Bushing
3.	RM-21-06	Sleeve, Vinyl (Cap. leads)	b)	4010-01086-14	Cap Screw, 10-32 x 7/8, SH
4.	5045-12098-00	Capacitor, 2.2 $\mu$ Fd, 250V, 20%	c)	4700-00023-00	Flatwasher, 5/8 x 13/64 x 16ga.
5.	4701-00002-00	Lockwasher, #6 Split	d)	4701-00004-00	Lockwasher, #10 Split
6.	4105-01019-10	Sh. Metal Screw, #5 x 5/8	e)	4410-01132-00	Nut, 10-32 ESNA
7.	23-6622	Tape, Double-sided	f)	A-10656*	Flipper Link Assembly
8.	4008-01079-05	Cap Screw, 8-32 x 5/16	1.)	02-4219	Coil Plunger
9.	4701-00003-00	Lockwasher, #8 Split	2.)	20-9370-1	Spring Pin, 5/32 dia. x 7/16
10.	01-9375	Switch Mounting Bracket	3.)	03-8050-1	Flipper Link
11.	03-7520-2	Ty-Wrap, Nylon	g)	B-10657-R	Flipper Crank Assy, R.
12.	20-6516	Speednut, Tinnerman	*	B-10657-L	Flipper Crank Assembly
13.	4010-01066-06	Cap Screw, 10-32 x 3/8, SH	1.)	01-8073-R	Flipper Crank, Right
14.	4701-00004-00	Lockwasher, #10 Split	*	01-8073-L	Flipper Crank, Left
15.	A-12111	Flipper Stop Assembly	2.)	17-1037	Crank Washer
16.	HW-30018-6	Wire, 18 AWG, Blue	3.)	4010-01066-18	Cap Screw, 10-32 x 1-1/8
17.	FL-11630	Flipper Coil (Red)	4.)	4410-01127-00	Nut, 10-32 Hex Head
18.	01-7695	Solenoid Bracket	5.)	4700-00107-00	Flatwasher, 5/8 x 13/64 x 12ga.
19.	4006-01017-04	Mach. Screw, 6-32 x 1/4	6.)	4701-00004-00	Lockwasher, #10 Split
20.	10-376	Coil Plunger Spring	7.)	RM-23-06	Tubing, H. S. 1/4 DWP
			22.	23-6577	Bumper Plug
			23.	03-7568	Flipper Bushing
			24.	4006-01005-06	Mach. Screw, 6-32 x 3/8
			25.	4406-01117-00	Nut, 6-32 Hex.

\* Items for *Left Flipper Assembly* Only.

**Flipper Assembly Notes...**

- Each Flipper Assembly on the Lower Playfield is mounted beneath the playfield, in conjunction with the plastic Flipper Paddle and Shaft (20-9250-6) and Flipper Rubber (23-6519-4) on the upper side of the playfield.
- The tip of the EOS Switch must travel 0.150 (+ .010, - .000) inch, before the contacts fully open, with the flipper in the actuated position. The EOS Switch contacts must have a gap of 0.062 ( $\pm$  .015) inch. Adjustment of the EOS Switch must be made at a minimum distance of 0.25 inch from the switch body.
- All moving elements of the assembly must operate freely, with no evidence of binding.
- The large end of the Coil Plunger Spring (item 20) must fit within the four lugs of the Solenoid Bracket.
- For coil replacement, remove the Solenoid Bracket (Item 18) to prevent screw damage.
- Use Loctite™ 242 when reattaching screws to the Flipper Stop Assembly, the Solenoid Bracket, and the Flipper Bushing.
- When replacing their Bumper Plug (item 22) to restore proper flipper operation, readjust the flipper paddle and shaft position.
- Solid-color blue wire connects to the banded end of each diode, mounted on the connector end of the Flipper Coil (item 17). Trace-color wire connects to the unbanded end of the diode.



# C-13174-R & C-13174-L Flipper Assembly

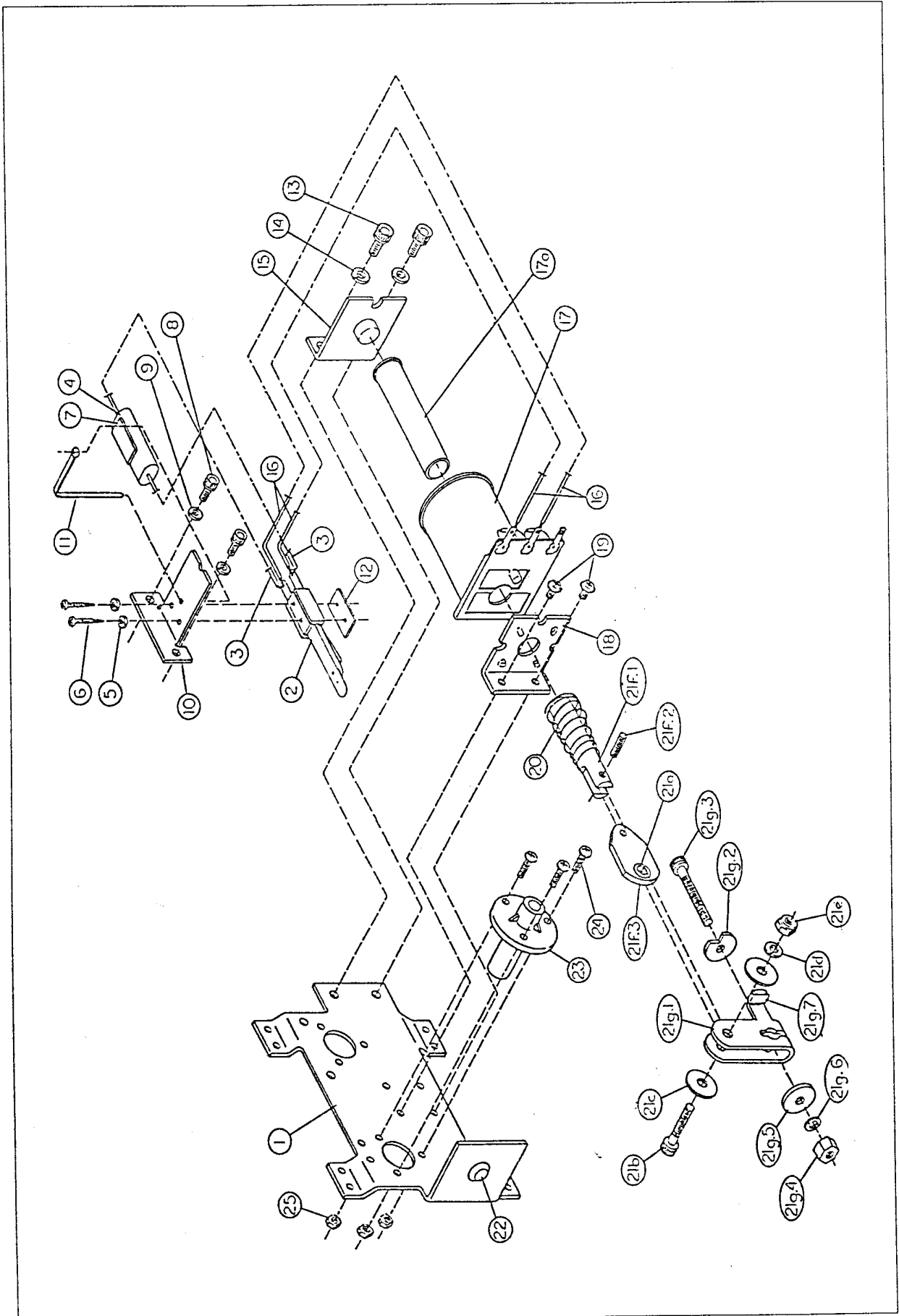

## C-9638 Ball Shooter Lane Feeder

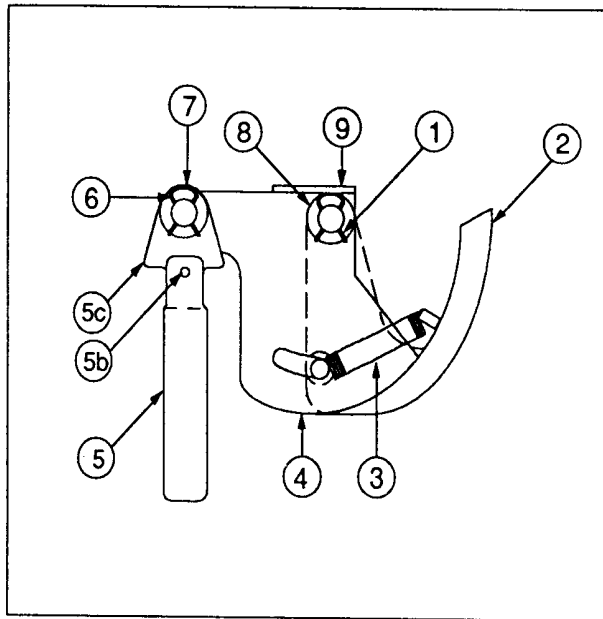

Item	Part Number	Description
1.	12-6227	Hair Pin Clip
2.	A-8247	Eject Cam Assembly
3.	10-362	Ejector Spring (Plain)
4.	A-6949-L	Spring Plate Assembly
5.	A-8050-1	Coil Plunger Assy, 2-1/8"
a)	02-3407-2	Coil Plunger, 2-1/8"
b)	20-8716-5	Roll Pin, 1/8 x 7/16
c)	03-8085	Armature Link
6.	12-6227	Hair Pin Clip
7.	4700-00030-00	Flatwasher, 17/64 x 1/2 x 15ga.
8.	4700-00103-00	Flatwasher, 17/64 x 1/2 x 28ga.
9.	A-8268	Mounting Bracket Assembly

### Associated Parts

B-9362-R-3	Coil & Bracket Assembly
B-7572-1	Bracket & Stop Assembly
01-8-508-S	Coil Retaining Bracket
4006-01017-06	Mach. Screw, 6-32 x 3/8
4406-01119-00	Nut, 6-32 ESN
AE-26-1200	Coil Assembly
03-7066	Coil Tubing

## A-8039-3 Outhole Kicker Assembly

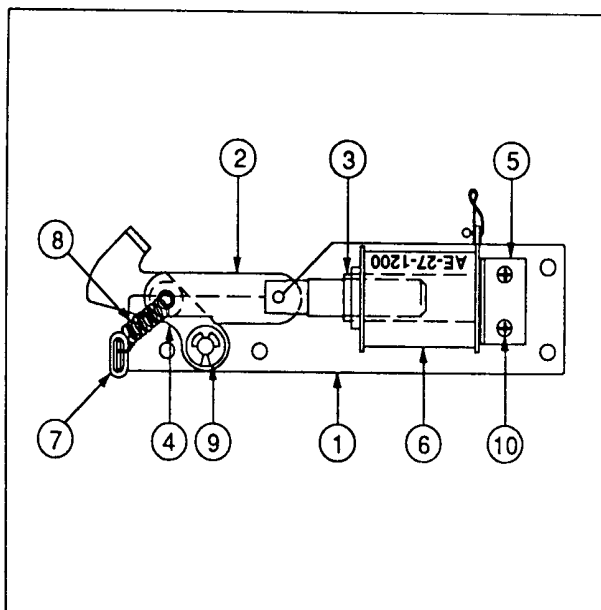

Item	Part Number	Description
1.	A-6378	Mounting Plate Assembly
2.	A-8335	Coil Plunger Assembly
a)	02-2364	Coil Plunger
b)	20-8716-5	Roll Pin, 1/8 x 7/16
c)	01-4251	Ball Return Link
3.	03-7066	Coil Tubing
4.	A-6889	Kicker Lever Assembly
5.	A-8038	Coil Stop Assembly
6.	AE-27-1200	Coil Assembly
7.	03-7176-1	Striker Ring
8.	10-101-4	Spring-Reset
9.	20-8712-25	"E" Ring, 1/4" Shaft
10.	4006-01003-03	Mach. Screw, 6-32 x 3/16

## B-12665 Kicker Arm (Slingshot) Assembly w/Coil & Bracket Assembly (B-13935)

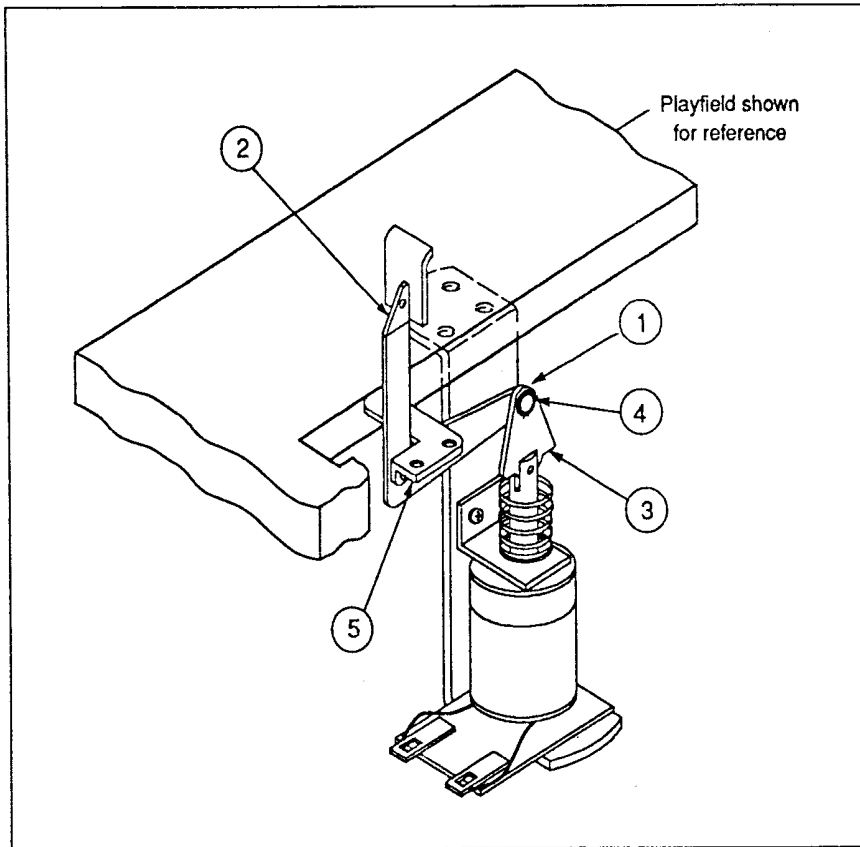

Item	Part Number	Description
1.	12-6227	Clip, Hairpin
2.	A-12664	Kicker Crank Assembly
3.	A-5103	Coil Plunger Assembly
a)	02-2364	Coil Plunger
b)	20-8716-5	Roll Pin, 1/8 x 7/16
c)	03-8085	Armature Link
4.	4700-00030-00	Flatwasher, 17/64 x 1/2 x 15ga.
5.	A-5653	Mounting Bracket Assembly

### Associated Parts for Left Kicker

B-13935	Coil & Bracket Assembly
B-7572-1	Bracket & Stop Assembly
01-8-508-S	Coil Retaining Bracket
4006-01017-06	Mach. Screw, 6-32 x 3/8
4406-01119-00	Nut, 6-32 ESN
AE-26-1500	Coil Assembly
03-7066	Coil Tubing

### Associated Parts for Right Kicker

B-13935	Coil & Bracket Assembly
B-7572-1	Bracket & Stop Assembly
01-8-508-S	Coil Retaining Bracket
4006-01017-06	Mach. Screw, 6-32 x 3/8
4406-01119-00	Nut, 6-32 ESN
AE-26-1500	Coil Assembly
03-7066	Coil Tubing

## B-9414-3 Jet Bumper Assembly

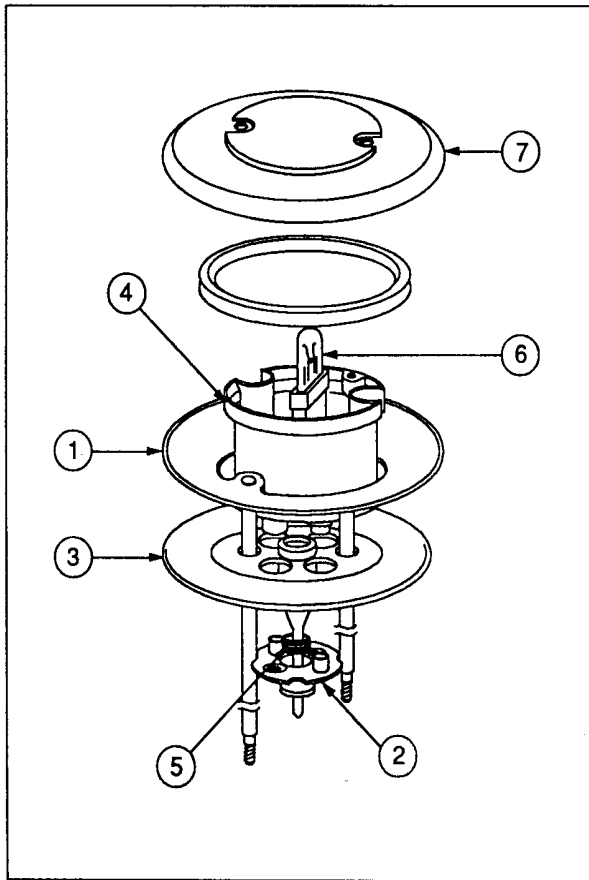

Item	Part Number	Description
1.	A-4754	Bumper Ring Assembly
2.	03-6009-A5	Bumper Base - White
3.	03-6035-4	Bumper Wafer - Red
4.	03-7443-5	Bumper Body - White
5.	10-7	Spring - Jet Bumper
6.	A-11199	Socket & Bulb Assy.
a)	24-8768	Bulb #555 (6.3v)
b)	24-8776	Wedge Socket Base

### Associated Part:

7.	03-8254-9	Jet Bumper Cap - Red
----	-----------	----------------------

## A-9415-2 Jet Bumper Coil Assembly

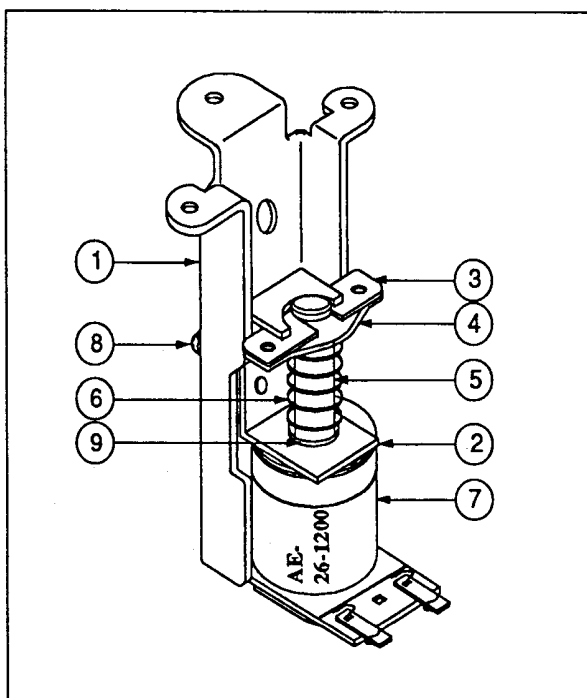

Item	Part Number	Description
1.	B-7417	Bracket & Stop Assembly
2.	01-1747	Coil Retaining Bracket
3.	01-5492	Armature Link, Steel
4.	01-5493	Armature Link, Bakelite
5.	02-3406-1	Coil Plunger
6.	10-326	Armature Spring
7.	AE-26-1200	Coil Assembly
8.	4006-01017-04	Mach. Screw, 6-32 x 1/4
9.	03-7066	Coil Tubing

### Associated Parts

B-12030-2	Jet Bumper Sw & Diode Assy
B-12029-2	Jet Bumper Sw & Brkt. Assy
SW-11A-37	Jet Bumper Switch Assy
5070-09054-00	Diode, 1N4004

## Ball Trough Switches

(Viewed from underside of playfield to show locations)

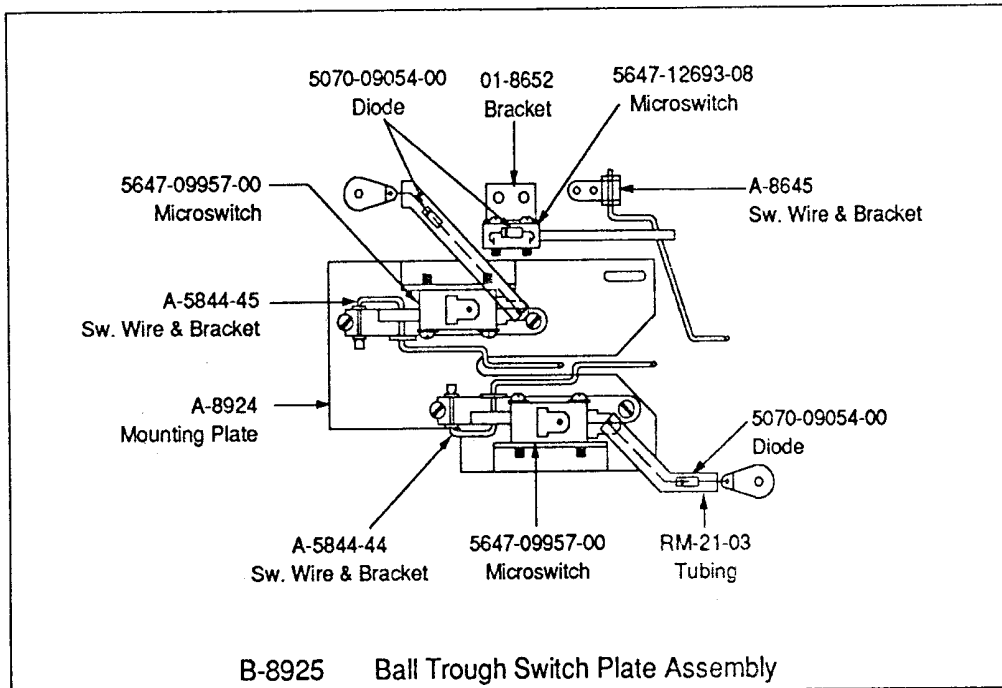

## B-10686-1 Knocker Assembly

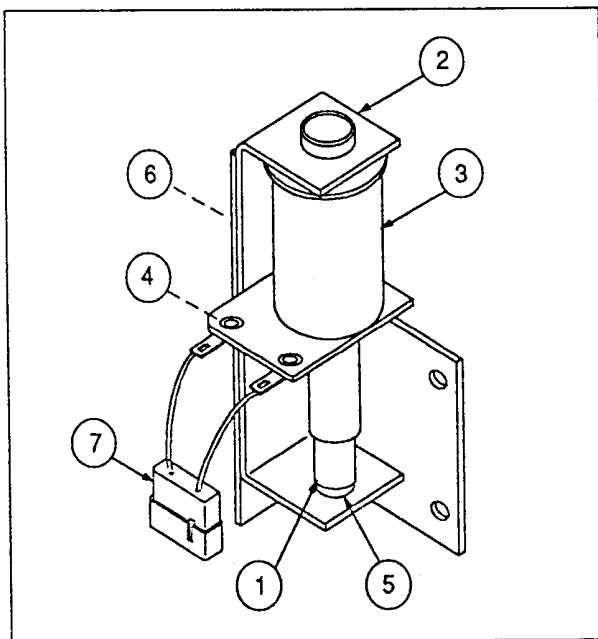

Item	Part Number	Description
1.	A-5387	Coil Plunger Assembly
a)	02-2653	Coil Plunger
b)	03-6013	Bell Arm Ext.
2.	B-7409-2	Mtg. Bracket Assembly
3.	AE-23-800	Coil Sub-Assembly
4.	01-8-508-T	Coil Retaining Bracket
5.	23-6420	Rubber Grommet
6.	4008-01017-06	Mach. Screw, 8/32 x 3/8
7.	H-11835	Knocker Cable
8.	03-7067-5	Coil Tubing

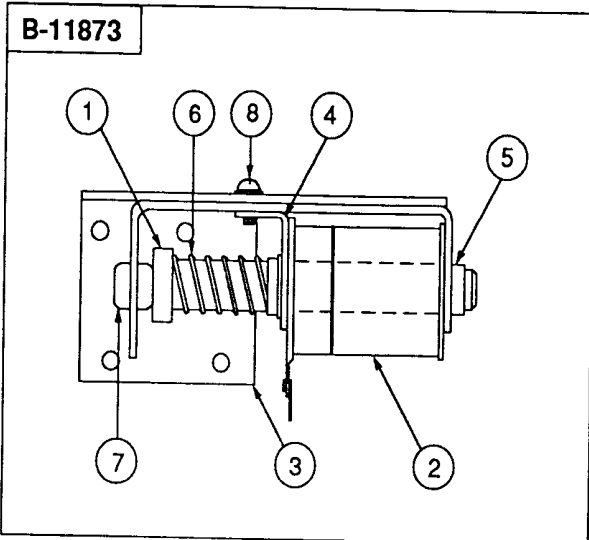

### B-11873 Kickback Assembly (Left)

Item	Part Number	Description
1.	A-6306-2	Bell Armature Assy.
2.	AE-23-800	Coil Assembly
3.	B-7409-2	Mounting Bracket
4.	01-8-508-T	Solenoid Bracket
5.	03-7067-5	Coil Tubing
6.	10-135	Solenoid Spring
7.	23-6420	Rubber Grommet
8.	4008-01017-05	Mach. Screw, 8-32 x 5/16"

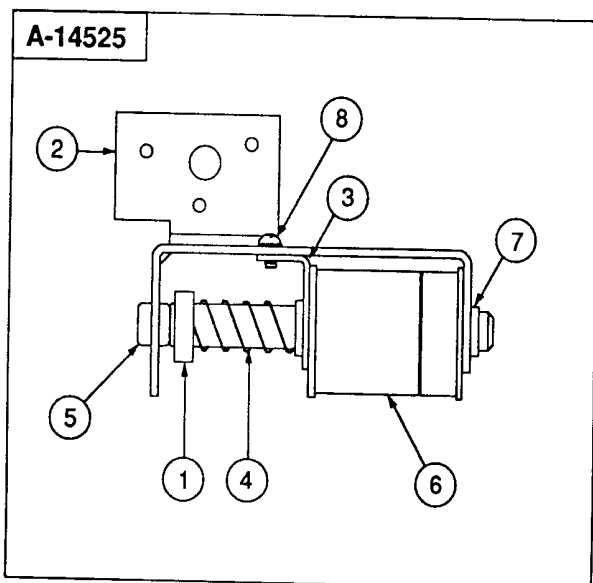

### A-14525 Kickback Assembly (Right)

Item	Part Number	Description
1.	A-6306-2	Bell Armature Assy.
2.	A-14526	Mounting Bracket Assy.
3.	01-8-508-T	Solenoid Bracket
4.	10-135	Solenoid Spring
5.	23-6420	Rubber Grommet
6.	AE-23-800	Coil Assembly
7.	03-7067-5	Coil Tubing
8.	4008-01017-05	Mach. Screw, #8-32 x 5/16"

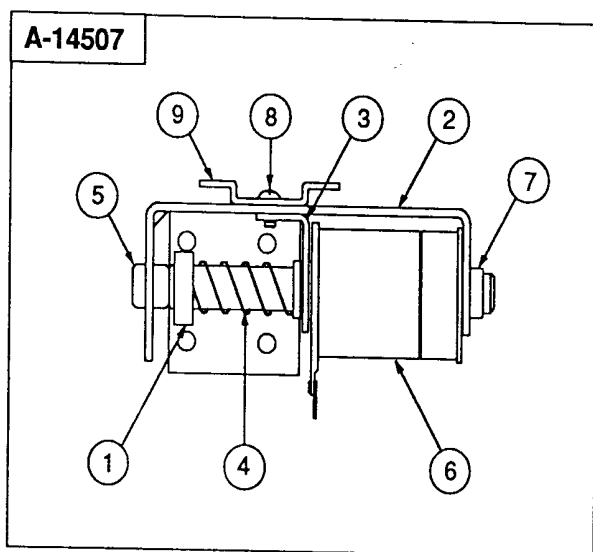

### A-14507 Gun Kicker Assembly

Item	Part Number	Description
1.	A-6306-2	Bell Armature Assy.
2.	01-9595-2	Mounting Bracket Assy.
3.	01-8-508-T	Solenoid Bracket
4.	10-135	Solenoid Spring
5.	23-6420	Rubber Grommet
6.	AE-24-900	Coil Assembly
7.	03-7067-5	Coil Tubing
8.	4008-01017-05	Mach. Screw, #8-32 x 5/16"
9.	01-10298	Mounting Bracket

## Ball Eject Assemblies

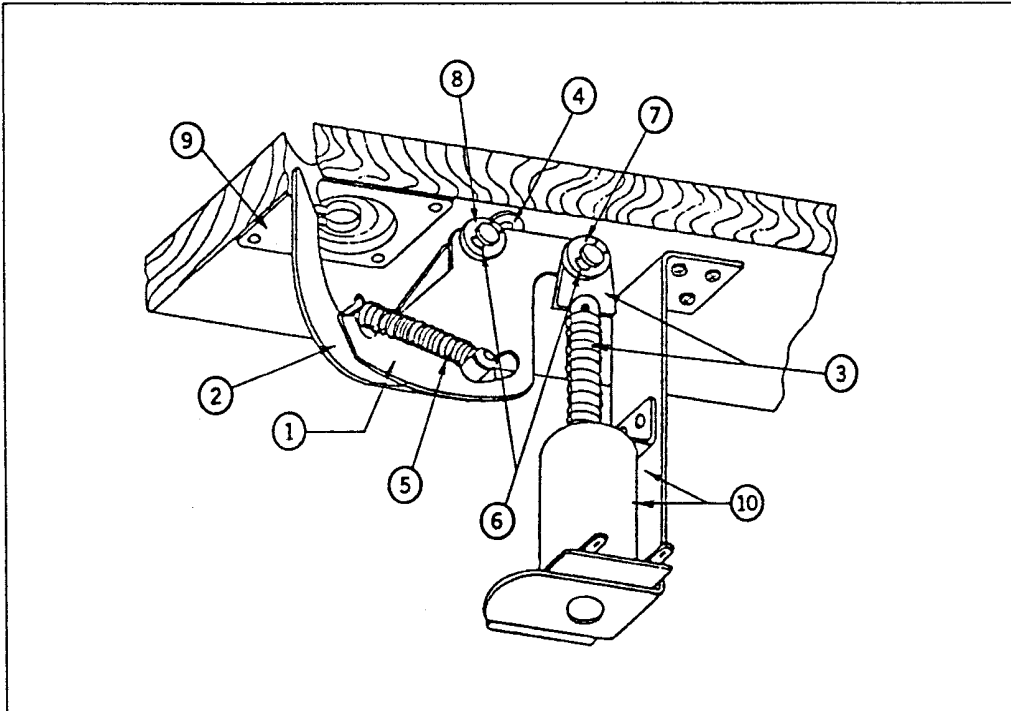

### B-9361-R Ball Eject Assembly

Item	Part Number	Description
1.	A-6949-R	Spring Plate
2.	A-7471-R	Eject Cam Assembly
3.	A-8050	Plunger Assy., 2-1/4"
a)	02-3407	Plunger Coil
b)	03-8085	Armature Link
c)	20-8716-5	Roll Pin 1/8 x 7/16
4.	A-8268	Mounting Bracket Assy.
5.	10-362	Eject Spring
6.	12-6227	Hairpin Clip
7.	4700-00030-00	FW, 17/64 x 1/2 x 15ga.
8.	4700-00103-00	FW, 17/64 x 1/2 x 28ga.

#### Associated Parts:

9.	03-7351-1-9	Eject Shield
10.	B-11203-R-1	Coil & Bracket Assy.
a)	AE-26-1500	Coil Assembly
b)	B-7572-1	Bracket & Stop Assy.
c)	01-8-508-S	Coil Retainer Bracket
d)	03-7066	Coil Tubing
e)	4006-01017-06	Mach. Screw, 6-32 x 3/8
f)	4406-01119-00	Nut, 6-32 ESN

### B-9361-R-6 Ball Eject Assembly

Item	Part Number	Description
1.	A-6949-R	Spring Plate
2.	A-7471-R	Eject Cam Assembly
3.	A-8050	Plunger Assy., 2-1/4"
a)	02-3407	Plunger Coil
b)	03-8085	Armature Link
c)	20-8716-5	Roll Pin 1/8 x 7/16
4.	A-8268	Mounting Bracket Assy.
5.	10-320	Eject Spring
6.	12-6227	Hairpin Clip
7.	4700-00030-00	FW, 17/64 x 1/2 x 15ga.
8.	4700-00103-00	FW, 17/64 x 1/2 x 28ga.

#### Associated Parts:

9.	03-7351-1-9	Eject Shield
10.	B-11203-L-1	Coil & Bracket Assy.
a)	AE-26-1500	Coil Assembly
b)	B-7572-1	Bracket & Stop Assy.
c)	01-8-508-S	Coil Retainer Bracket
d)	03-7066	Coil Tubing
e)	4006-01017-06	Mach. Screw, 6-32 x 3/8
f)	4406-01119-00	Nut, 6-32 ESN

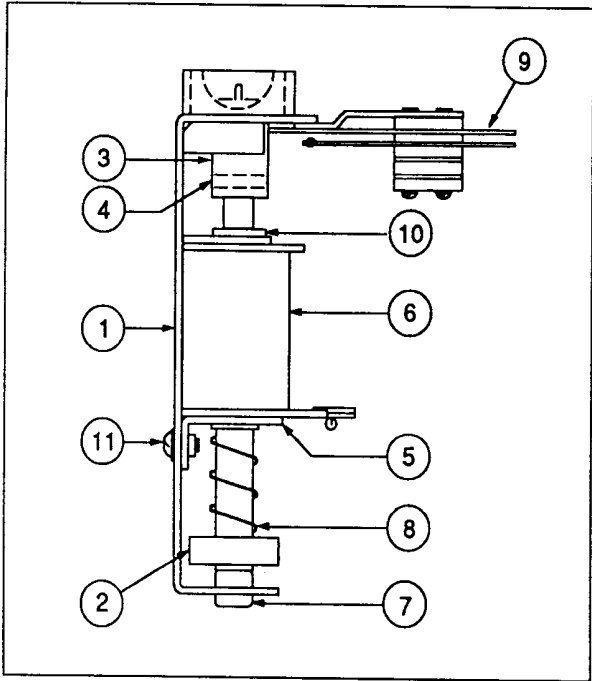

## A-14501 Ball Popper Assembly

Item	Part Number	Description
1	A-14485	Bracket Assembly
2	A-11336	Armature Assembly
3	03-8053	Ball Popper Cap
4	20-9314-7	Dowel Pin, 3/32 x 1/2
5	01-9794	Mounting Bracket
6	AE-23-800	Coil Assembly
7	23-6420	Rubber Grommet
8	10-135	Spring
9	A-11657-1	Switch Assembly
10	03-7067	Coil Tubing
11	4008-01017-04	Mach. Screw, #8-32 x 5/16

## Standup Target Assemblies

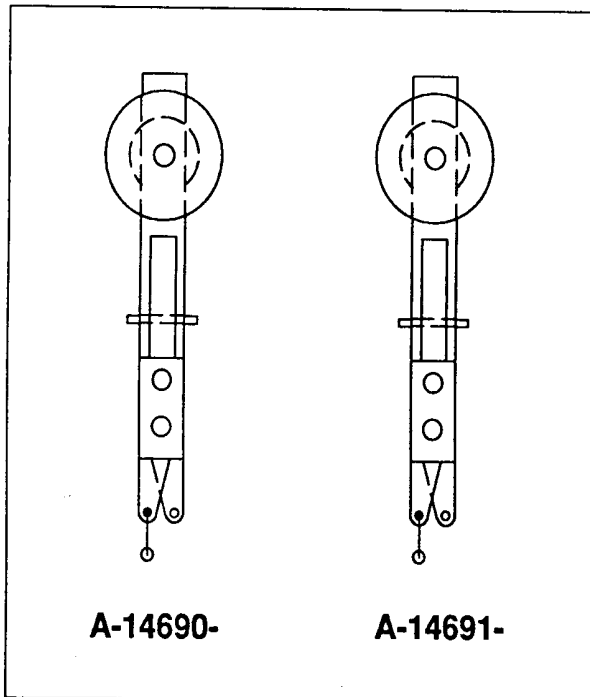

### A-14690-5 Standup Target -White

Part Number	Description
03-8093-5	Target, White
5070-09054-00	Diode, 1N4001, 1.0A.

### A-14690-15 Standup Target - Orange

Part Number	Description
03-8093-15	Target, Orange
5070-09054-00	Diode, 1N4001, 1.0A.

### A-14691-4 Standup Target - Red

Part Number	Description
03-8093-4	Target, Red
5070-09054-00	Diode, 1N4001, 1.0A.



## A-14615 1-Bank Drop Target Assembly

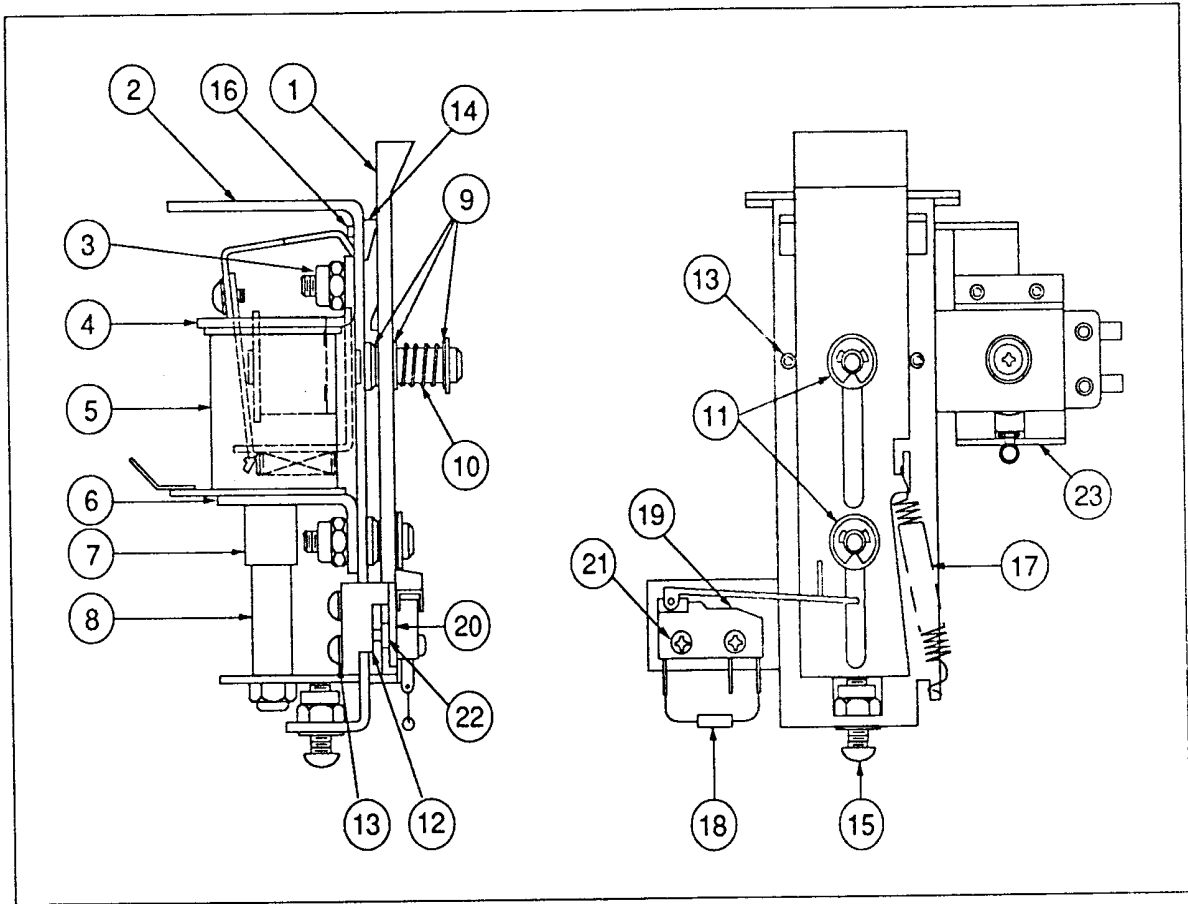

Item	Part Number	Description
1.	03-8033	Target - Flush
2.	A-14617	Bracket & Post Assy.
3.	4408-0119-00	Nut 8-32 ESNA
4.	A-11397	Stop Bracket Assembly
5.	AE-26-1200	Coil Assembly
6.	01-8413	Coil Mounting Bracket
7.	03-7066-4	Tubing
8.	A-11388-2	Plate & Reset Assy.
9.	4700-00072-00	Flatwasher, 17/64 x 1/2"
10.	10-392	Spring
11.	20-8712-25	"E"-Ring
12.	01-10183	Switch Bracket
13.	4006-01003-03	Mach. Screw, 6-32 x 3/16
14.	03-8034	Single Stop Target
15.	4010-01025-14	Mach. Screw, 10-32 x 7/8 P-RH
16.	07-6688-17N	Rivet, 5/32 x 7/32
17.	10-433	Spring Extension
18.	5070-09054-00	Diode 1N4001
19.	5647-12693-31	Switch
20.	01-8600	Switch Insulator
21.	4002-01105-08	Mach. Screw, 2-56 x 1/2
22.	01-8240	Nut Plate
23.	A-14908	Target Knock Down Assembly
a)	01-8647-L	Actuator
b)	A-14913	Frame & Eyelet Assembly
c)	SM1-26-600	Coil Assembly

# A-14504 Platform Gun Assembly

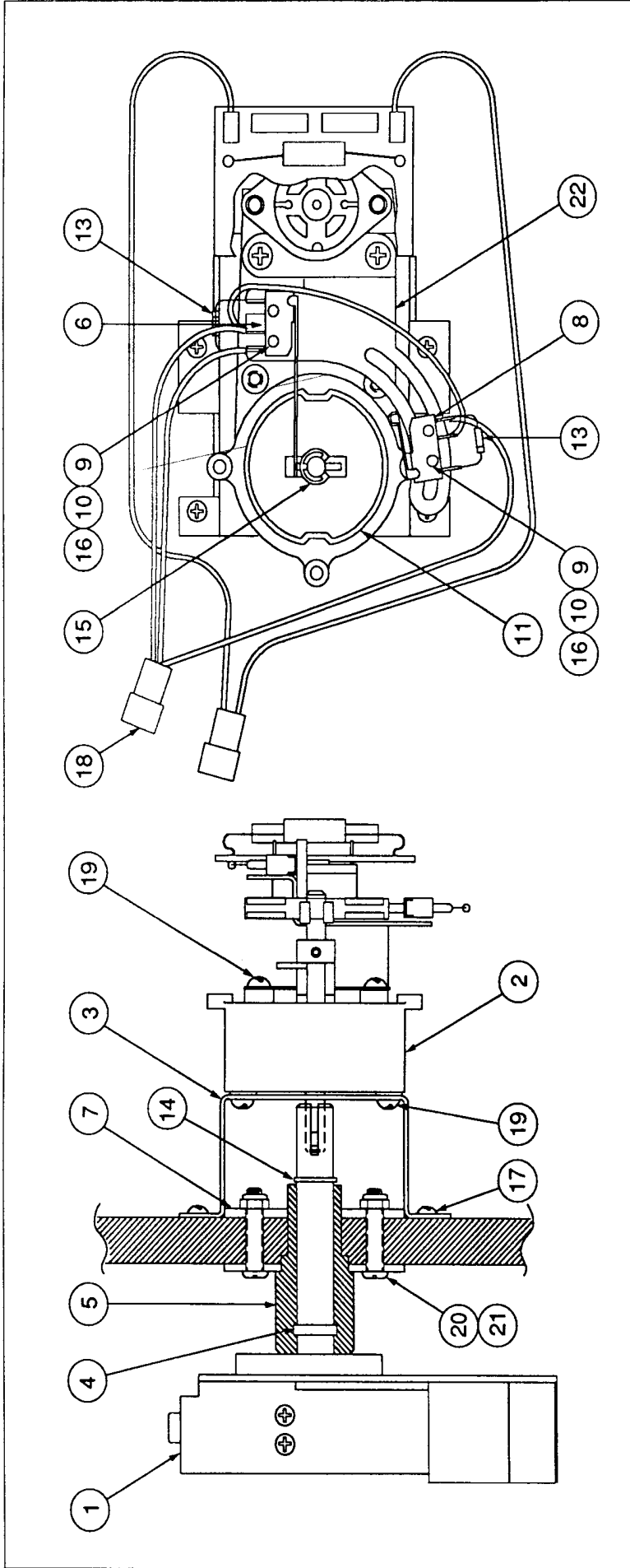

Item	Part Number	Description	Item	Part Number	Description
1.	A-14505	Platform/Kicker Assy. (See p. 2-25)	12.	H-14576	Cannon Cable
2.	14-7963	Motor Pitch	13.	5070-09054-00	Diode, 1N4004
3.	01-10061	Bracket (Motor Mounting)	14.	20-8712-50	"E"-Ring Retainer, 1/2"
4.	EI-204	Teflon Grease - Magnalude	15.	20-8712-25	"E"-Ring Retainer, 1/4"
5.	A-14459	Bushing Staked Assembly	16.	4002-01105-08	Mach. Screw, #2-56 x 1/2 SEMS
6.	5647-12693-31	Switch	17.	4108-01019-08	Sh. Screw, #8-18 x 1/2
7.	01-10060	Plate Bushing	18.	H-14943	Motor Cable
8.	5647-12693-06	Subminiature Switch	19.	4008-01017-03	Mach. Screw, #8-32 x 3/16 SEMS
9.	01-8600	Insulator Switch	20.	4408-01119-00	Nut #8-32 ESN
10.	01-8240	Nut Plate	21.	4008-01003-16	Mach. Screw, #8-32 x 1
11.	A-14706	Cam-Gun	22.	01-10228	Switch Bracket

## A-14505 Platform & Kicker Assembly

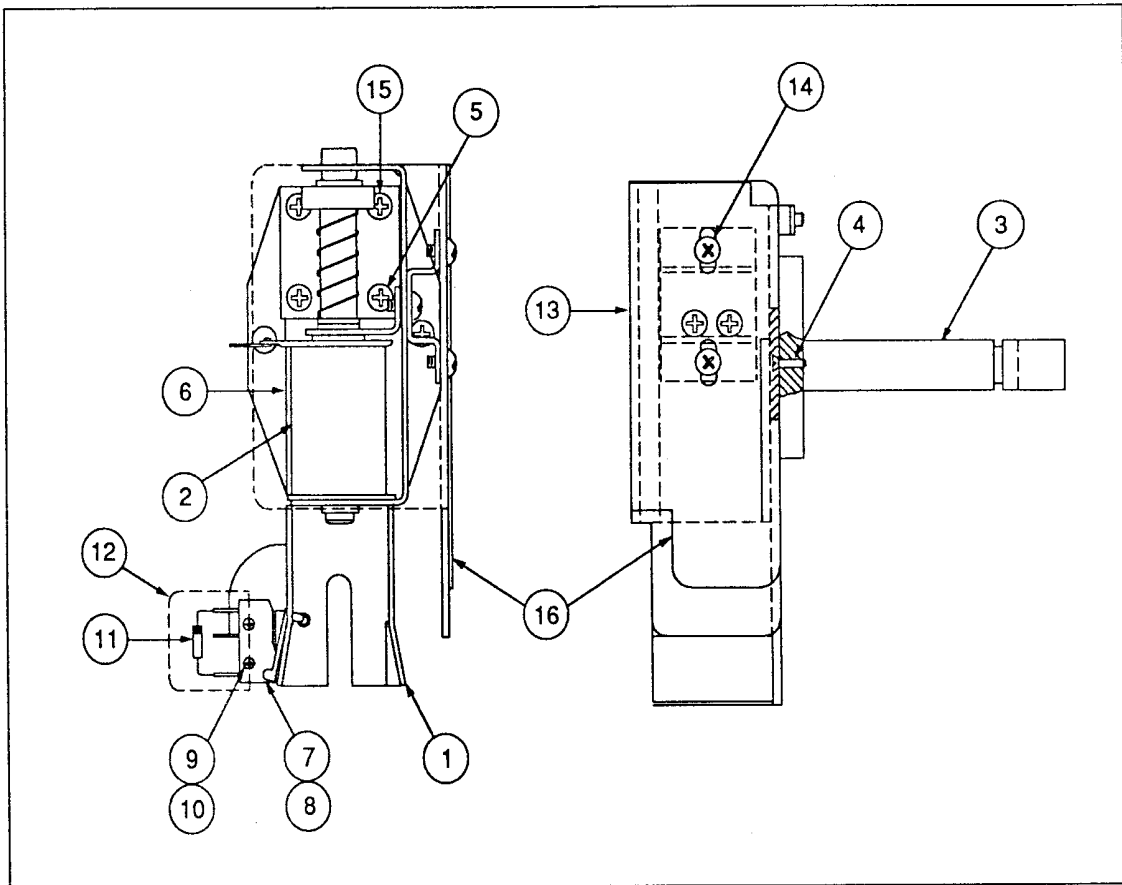

Item	Part Number	Description
1.	A-14480	Platform Welded Assembly
2.	A-14507	Kickback Assembly
3.	A-14597	Gun Shaft/Disk Assembly
4.	4008-01041-06	Mach. Screw, #8-32 x 3/8
5.	4008-01016-08	Mach. Screw, #8-32 x 1/2
6.	01-10119	Insulator Mylar
7.	5647-12693-06	Switch
8.	01-8600	Switch Insulator
9.	01-8240	Nut Plate
10.	4002-01105-08	Mach. Screw, #2-56 x 1/2
11.	5070-06258-00	Diode 1N4004
12.	20-9672	Cover Switch Protect
13.	01-10301	Gun Cover
14.	4008-01017-03	Mach. Screw, #8-32 x 3/16
15.	4008-01017-05	Mach. Screw, #8-32 x 5/16
16.	31-2-50013-2	Decal (1st Surface)

## A-14680 Gun Handle Assembly

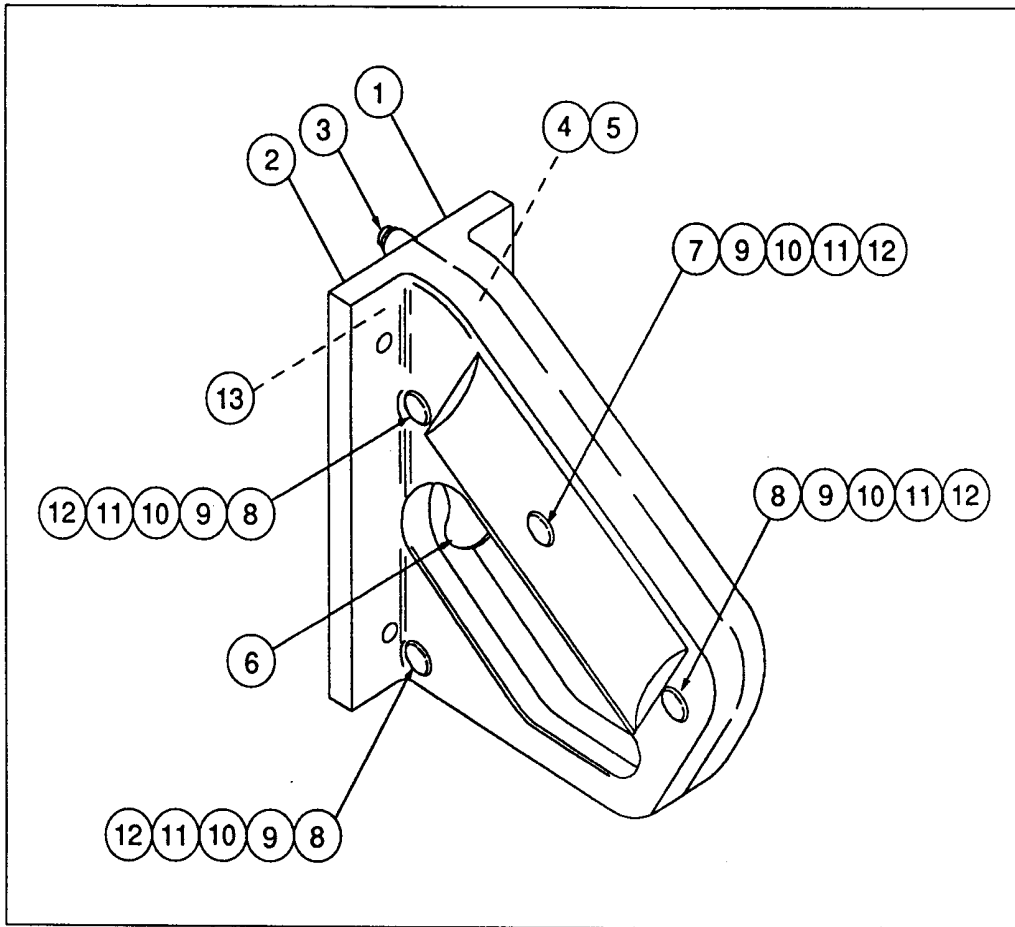

Item	Part Number	Description
1.	21-6686-L	Gun Handle, Left
2.	21-6686-R	Gun Handle, Right
3.	A-14712	Bushing Firing Pin Assembly
4.	10A-304	Spring
5.	02-4558	Firing Pin Assembly
6.	A-14694	Trigger Assembly
7.	02-4546	Fastner- Button Head
8.	02-4547	Fastner- Button Head
9.	4010-01097-06B	Mach. Screw, #10-32 x 3/8"
10.	4700-00129-00B	Flatwasher, 13/64 x 15/32
11.	4702-00014-00B	Lockwasher 1/4" Internal Tooth
12.	4702-00013-00B	Lockwasher, #10 Internal Tooth
13.	4006-01003-08	Mach. Screw, 6-32 x 1/2 Hd. SEMS

## A-14772 Skull Rivet Assembly

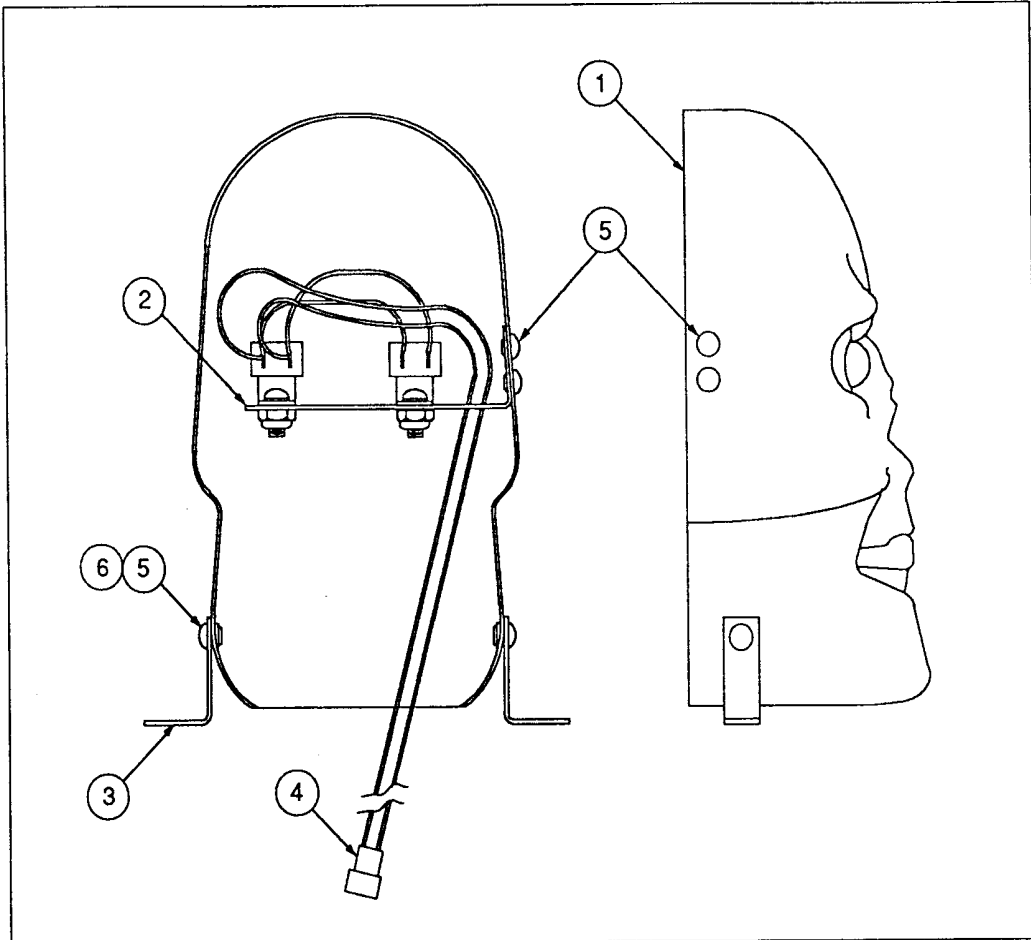

Item	Part Number	Description
1	03-8569	Skull
2	A-14773	Lamp Bracket Assembly
a)	24-8768	Bulb #555, 6.3V
b)	24-8807-1	Socket Wedge Base
3	01-10279	Mounting Bracket
4	H-14573	Cable
5	07-6688-18N	Rivet, 1/8 x 3/16"
6	4700-00003-00	Flatwasher, 1/8 x 9/32 x 21ga.

# A-14148-1 Coin Door Assembly

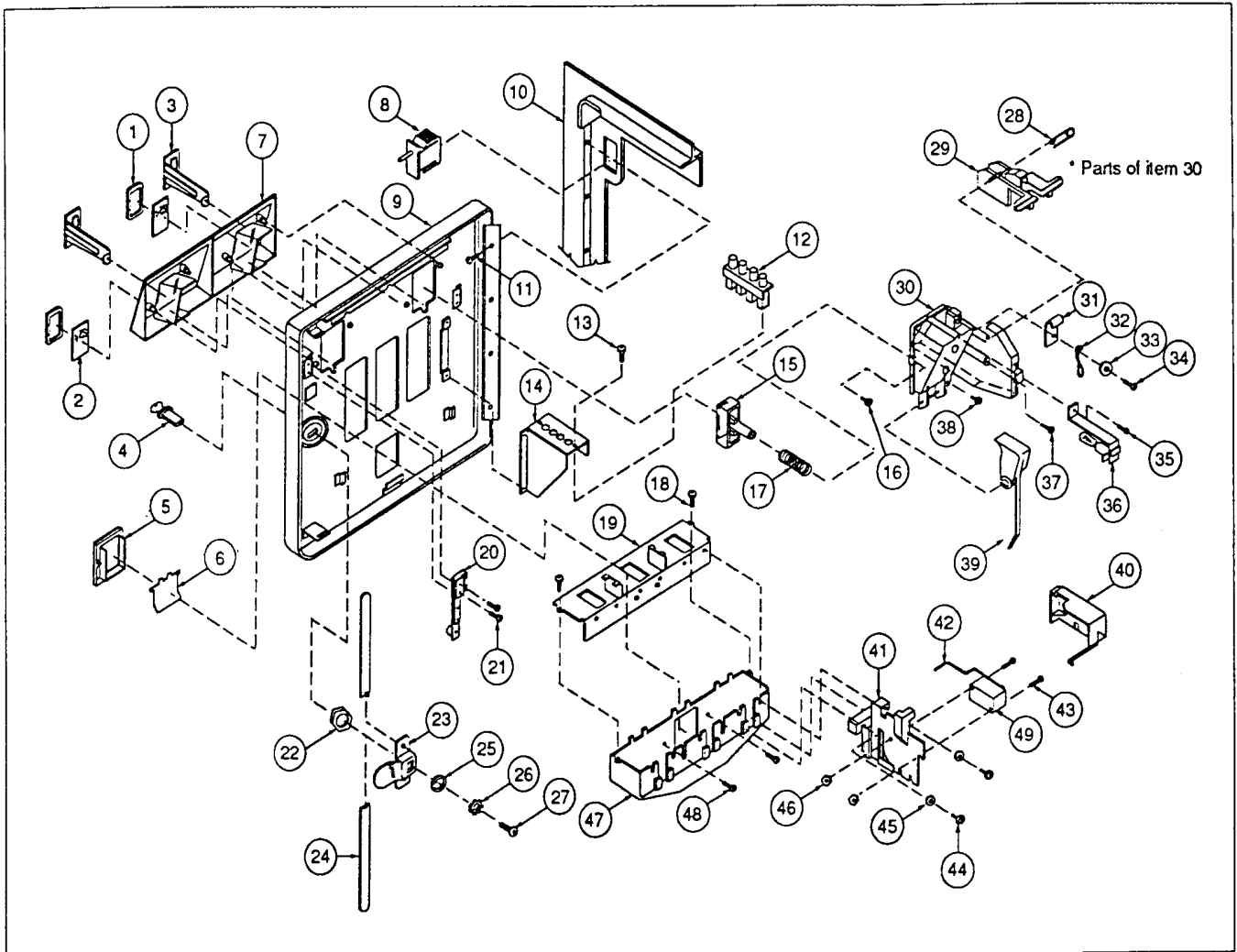

U.S.A. Door with Decals



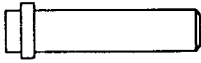
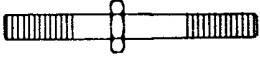
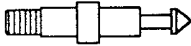

\* Parts of item 30

Item	Part No.	Description	Quantity	Item	Part No.	Description	Quantity
1	27-1038	Button Cover	2 or 3	26	27-1018	Star Washer	1
2	27-1041-1→58	Price Panel	2 or 3	27	27-1019	M/C Screw, 1/4-28 x 5/16	1
3	27-1026-1→17	Coin Entry Plate	2 or 3	28	Not Used		
4	27-1016	Lock Assembly	1	29	Not Used		
5	27-1061-1	Coin Return - Bezel	1	30	27-1112	Coin Inlet Chute	2 or 3
6	27-1062	Coin Return Flap	1	31	27-1088	Cable Clamp	2 or 3
7	27-1021	Button Housing - 2-slot	1	32	27-1025	Key Hook	1
	27-1022	Button Housing - 3-slot	1	33	27-1086	Washer, #6	2 or 3
8	27-1111	Interlock Switch	1	34	27-1078	M/C Screw, 6-32 x 3/8	1 or 2
9	27-1006-1	Coin Door, 2-Slot	1		27-1113	M/C Screw, 6-32 x 7/16	1
	27-1007-1	Coin Door, 3-Slot	1	35	27-1079	Self-tapping Screw, #6 x 1/4	2 or 3
10	27-1005	Coin Door Frame	1	36	27-1084	Lamp Socket	2 or 3
11	27-1003	M/C Screw, 6-32 x 3/16	4		27-1085	Lamp	2 or 3
12	5641-12724-00	Diagnostic Switch	1	37	27-1096	Self-tapping Screw, #5 x 3/8	2 or 3
13	27-1101	M/C Screw, 4-40 x 1/4	2	38	27-1087	M/C Screw, 6-32 x 5/8	2 or 3
14	01-9885	Bracket, Diagnostic Switch	1	39	27-1082	Lever Arm	2 or 3
15	03-7601-4	Button, Red	2	40	27-1097	Switch Cover	2 or 3
	03-7601-7	Button, Black	2	41	27-1091-1	Coin Accept Chute	2 or 3
16	27-1078	M/C Screw, 6-32 x 3/8	2 or 3	42	27-1075	Wire Form (Small)	2 or 3
17	27-1039	Conical Spring	2 or 3		or		
18	27-1079	Self-tapping Screw, #6 x 1/4	2		27-1093	Wire Form (Large)	
19	27-1077-1	Coinbox Cover	1	43	27-1094	M/C Screw, 4-40 x 7/8	4 or 6
20	27-1066	Slam Switch	1	44	27-1087	M/C Screw, 6-32 x 5/8	4 or 6
21	27-1067	M/C Screw, 4-40 x 1/2	2	45	27-1086	Washer, #6	4 or 6
22	27-1017	Nut (key)	1	46	27-1095	Nut, 4-40 ESNA	4 or 6
23	27-1012	Locking Cam	1	47	27-1076-1	Coin Return Box	1
24	27-1011	Locking Arm	2	48	27-1078	M/C Screw, 6-32 x 3/8	2
25	27-1020	Washer	1	49	27-1092	Microswitch	2 or 3

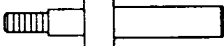
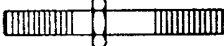
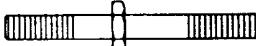
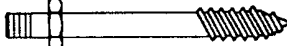
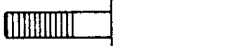
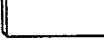
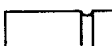
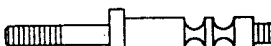
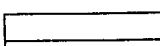
## Metal & Plastic Posts

	Part Number	Description	Quantity
	02-3409	Spring Post	3
	02-3905	Bumper Post, #8 WS	1
	02-4003	Bumper Post, 8-32	1
	02-4020	Support Post	3
	02-4036	Rubber Bumper Post	12
	02-4424-1	Spring Post, 6-32 x 8-32	7
	02-4425-1	Post, 8-32 / #8-32	2
	02-4426-1	Post, #6-32 / #8 SMS	1
	02-4322-3	M-F Spacer, 8-32 x 4.18"	1
	02-4433	Post, #8 x 1-3/16"	2
	02-4434	Post, #8 x 1"	2
	02-4423	Bumper Post	2
	02-4436-4	Spacer, 8-32 x 3.12"	1

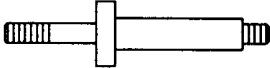
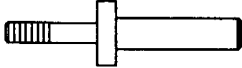
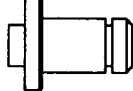
## Metal & Plastic Posts (Continued)

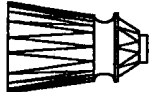
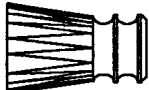
	Part Number	Description	Quantity
	02-4450	Post Double Bumper	5
	02-4056	Threaded Bumper Post	3
	02-4057	Short Bumper Post	4
	02-4271-1	Post	1
	02-4535	Post	1
	03-8319-13	Star Post, #8 (Clear)	19
	03-8247-13	Double Star Post, Clear	5



## Unique Parts List

Part Number	Description	Part Number	Description
A-12738-50013	WPC Audio Sound Board	A-14772	PLastic Skull
A-12742-50013	WPC CPU Assembly	A-14784	Playfield Plastic Rivet Assy.
A-13204-50013	Bottom Arch Assembly	A-14785	Playfield Plastic Rivet Assy.
A-13769-50013	Playfield & Insert Assembly	A-14812	Ramp Assembly Complete
A-14039	Dot Matrix Controller Assembly		
A-14092-1	Mounting PLate Assembly		
A-14376-50013	Backbox Assembly	H-14572	Right Ramp Cable
A-14457	Speaker/Display Assembly	H-14573	Eye Cable
A-14481	Ball Guide Assembly	H-14574	Left Ramp Cable
A-14482	Ball Guide Assembly	H-14575	Wireform Cable
A-14484	Ball Guide Assembly	H-14576	Cannon Cable
A-14486	Ball Guide Assembly	H-14577	Playfield Switch Cable
A-14488	Ball Guide Assembly		
A-14490	Wire Chute - Sw. Assembly	H-14578	Playfield Lamp Cable
A-14491	Wire Chute - Sw. Assembly	H-14579	Playfield Solenoid Cable
A-14501	Ball Popper Assembly	H-14580	Insert Cable
A-14502	Ramp Assembly, Left	H-14581	Cabinet Cable
A-14504	Platform Gun Assembly	H-14582	Secondary Cable
A-14505	Platform & Kicker Assembly	H-14583	Logic Power Cable
A-14507	Kickback Assembly	H-14584	Dot Matrix Display Cable
A-14516	4-Lamp Assembly		
A-14517	5-Lamp Assembly		
A-14518	G. I. Lamp Assembly	02-4535	Post
A-14519	5-Lamp Assembly		
A-14520	6-Lamp Assembly		
A-14521	5-Lamp Assembly	12-6466-25	Wireform, 6-1/4"
A-14525	Kicker Assembly	12-6466-45	Wireform, 4-5/8"
A-14536	Switch Gate Assembly	12-6466-46	Wireform, 5-5/8"
A-14558	Back Panel Assembly	12-6964	Wire Chute - Ball Popper
A-14596	Ball Guide Assembly	12-6965	Wire Chute - Left
A-14610	Ball Guide Assembly	12-6966	Wire Chute - Right
A-14614	Ball Guide Assembly		
A-14615	1- Bank Drop Target		
A-14623-1	EMI Filter Board Assy.	31-1-50013-	Playfield Plastics Set
A-14641-1	Cashbox Assembly	31-1002-50013	Screened Playfield
A-14680	Gun Handle Assembly	31-1008-50013	Screened Bottom Arch
A-14690-15	Standup Target - Orange	31-1009-50013	Screened Shooter Gauge
A-14690-5	Standup Target - White	31-1357-50013	Backglass
A-14691-4	Standup Target - Red		
A-14713-1	Playfield Plastic Assy.		
A-14713-2	Playfield Plastic Assy.	5555-12856-00	Speaker, 5-1/4, 40Ω, 25w
A-14713-3	Playfield Plastic Assy.	5610-12835-00	Transformer Assy, 115/230v
A-14713-4	Playfield Plastic Assy.	5795-10938-14	Ribbon Cable, 14"
A-14744-USA	Line Filter Assembly	5795-12837-01	Ribbon Cable,
A-14747	Gun Handle Assembly	5795-12838-30	Ribbon Cable,

## Playfield Parts

Item	Part Number	Description	Item	Part Number	Description
1.	A-8039-3	Outhole Kicker	41.	*03-7960-50013-1	Full Playfield Mylar
a)	A-10417	Outhole Switch	42.	*03-7960-50013-2	Jet Bumper Mylar
2.	A-14525	Right Kickback	43.	31-1-50013	Playfield Plastics
3.	C-9638	Eject Assembly	44.	Parts Under Bottom Arch	
a)	B-9362-R-3	Coil & Bracket Assy	a)	A-8039-3	Outhole Kicker Assembly
4.	B-8925	Switch Plate	b)	B-8623	Upper Trough Baffle
a)	A-11680	MicroSwitch	c)	C-8235	Lower Trough Baffle
5.	C-13174-R	Right Flipper	d)	C-9638	Shooter Lane Assembly
6.	B-12695	Rt. Flipper Ball Guide	e)	01-3569-1	Ball Trough (Runway)
7.	B-12665	Right Kicker	f)	01-5575	Bottom Arch Mounting Bracket
a)	B-13935	Coil & Bracket Assy	g)	12-6542	Trough Baffle Wire
8.	A-14690-15	Stand-up Targets			
9.	A-14610	Ball Guide			
10.	A-14534	Ball Guide			
11.	A-14504	Platform Assembly			
12.	A-14507	Gun Kicker			
13.	A-14491	Wire Chute			
14.	12-6466-45	Ball Guide Wireform			
15.	12-6968	Ball Guide Wireform			
16.	A-9415-2	Jet Bumpers			
a)	B-12030-2	Jet Bumper Switch Assy			
17.	12-6466-15	Ball Guide Wireform			
18.	A-14812	Right Ramp			
19.	A-14536	Ball Guide			
20.	01-6933	Eject Shield			
21.	A-9381-R	Switch			
a)	B-11203-R-1	Coil & Bracket Assy			
b)	B-9361-R	Eject Assembly			
22.	A-13505	Ball Guide			
23.	A-14501	Ball Popper			
24.	A-14615	Drop Target			
25.	A-14502	Ramp			
26.	A-14488	Ball Guide			
27.	12-6466-10	Ball Guide Wireform			
28.	12-6466-25	Ball Guide Wireform			
29.	12-6466-46	Ball Guide Wireform			
30.	A-14490	Wire Chute			
31.	A-14691-4	Stand-up Targets			
32.	A-14690-5	Stand-up Targets			
33.	12-6466-46	Ball Guide Wireform			
34.	A-9381-R	Switch			
a)	B-11203-L-1	Coil & Bracket Assy			
b)	B-9631-R-6	Eject Assembly			
35.	A-14484	Ball Guide Wireform			
36.	12-6466-17	Ball Guide Wireform			
37.	B-12665	Left Kicker			
a)	B-13935	Coil & Bracket Assy			
38.	B-8239-2	Lt. Flipper Ball Guide			
39.	C-13174-L	Left Flipper			
40.	B-11873	Left Kickback			

\*The Terminator 2 Hardcoat playfield does not require a mylar. However, mylars can be purchased thru your local Williams Distributor.

# Playfield Parts Locations

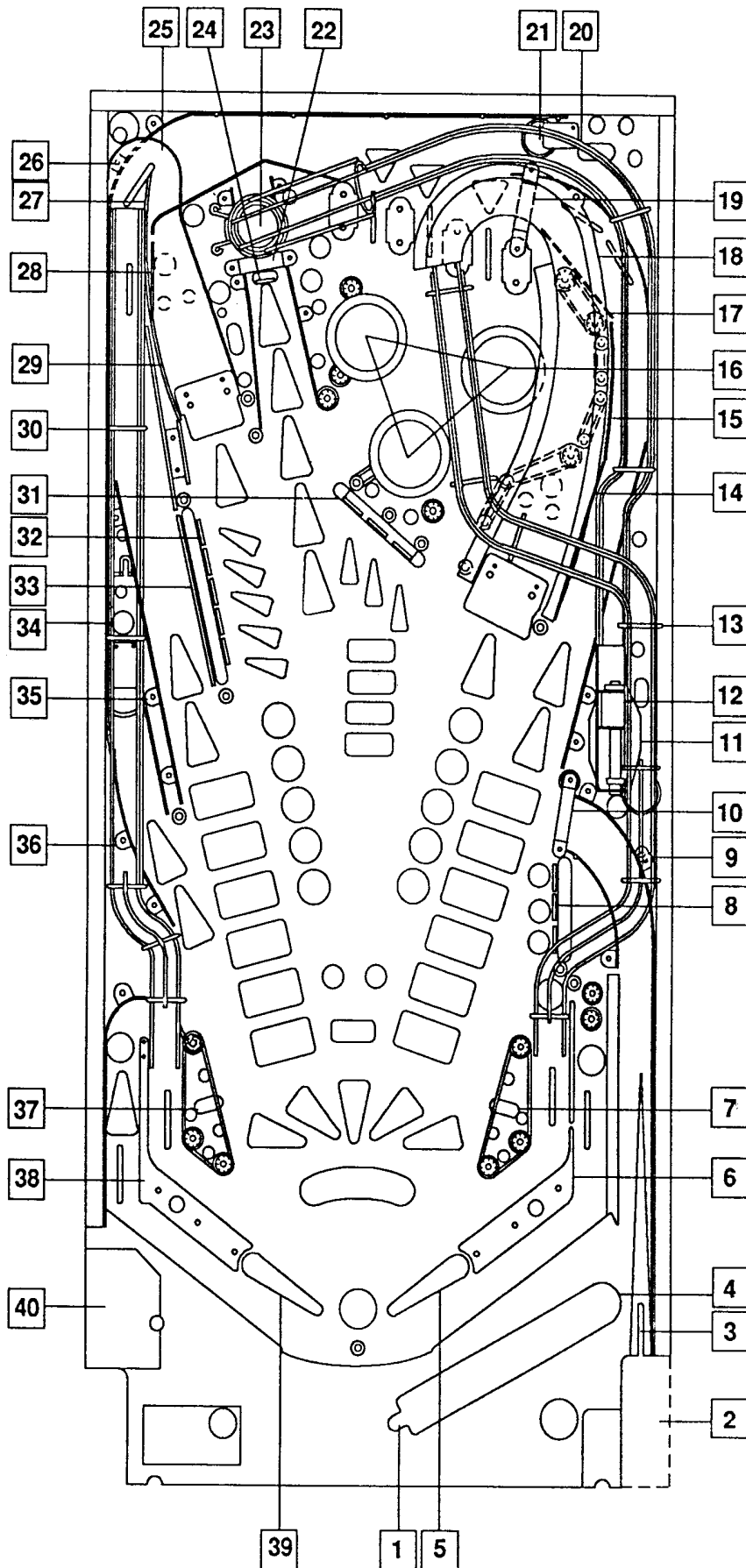

# Lamp Matrix

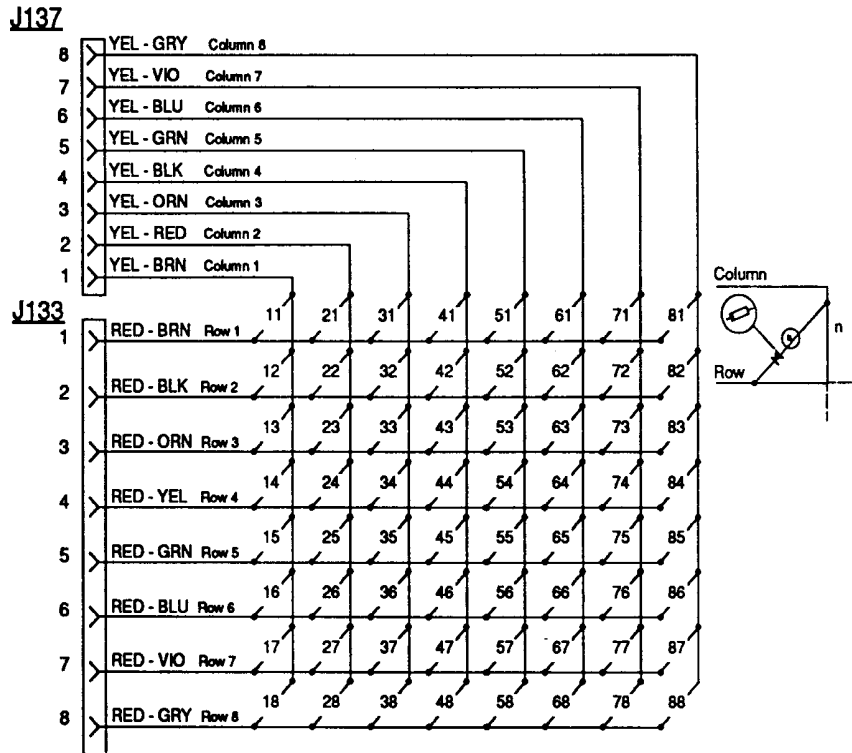

## Lamp Matrix

Column	1 Yellow-Brown J138-1 Q88	2 Yellow-Red J138-2 Q87	3 Yellow-Orange J138-3 Q86	4 Yellow-Black J138-4 Q85	5 Yellow-Green J138-5 Q84	6 Yellow-Blue J138-6 Q83	7 Yellow-Violet J138-7 Q82	8 Yellow-Gray J138-8 Q81
1 Red-Brown J133-1 Q80	Multiplier 2X	Kickback	Target 1 High	Lock Two	Eyes Lower	Left CPU Lit	Right CPU Lit	Chase Value
2 Red-Black J133-2 Q89	Multiplier 4X	Special	Target 2	Data Base 2	Eyes Upper	Left Vault Key	Right Vault Key	Right Ramp
3 Red-Orange J133-4 Q86	Hold Bonus	Left Return Lane	Target 3	10 Million	5,000,000	Left Silent Alarm	Right Silent Alarm	Hurry Up
4 Red-Yellow J133-5 Q87	Multiplier 6X	Right Return Lane	Target 4	Extra Ball	3,000,000	Left Passcode	Right Passcode	Start Button
5 Red-Green J133-6 Q86	Multiplier 8X	Data Base 3	Target 5 Low	Multi-ball	1,000,000	Left Checkpoint	Right Checkpoint	Drop Target
6 Red-Blue J133-7 Q85	Shoot Again	Load Gun	Middle Target Bank Left	Light Hurry Up	750,000	Lock 1	Right Bank Top	Top Lane Left
7 Red-Violet J133-8 Q84	Mouth	Extra Ball	Middle Target Bank Center	Hold Bonus	500,000	Data Base 1	Right Bank Middle	Top Lane Center
8 Red-Gray J133-8 Q83	Not Used	Load for Jackpot	Middle Target Bank Right	Security Pass	250,000	Left Ramp	Right Bank Bottom	Top Lane Right

# Lamp Locations

No.	Bulb	Description
11	#555	Multiplier 2X
12	#555	Multiplier 4X
13	#555	Hold Bonus
14	#555	Multiplier 6X
15	#555	Multiplier 8X
16	#44	Shoot Again
17	#44	Mouth 2
18	#555	Not Used
21	#555	Kickback
22	#555	Special 2
23	#555	Left Return Lane
24	#555	Right Return Lane
25	#555	Database 3
26	#555	Load Gun
27	#555	Extra Ball
28	#555	Load For Jackpot
31	#555	Target 1 High
32	#555	Target 2
33	#555	Target 3
34	#555	Target 4
35	#555	Target 5 Low
36	#555	Mid Left Target Bank
37	#555	Mid Center Target Bank
38	#555	Mid Right Target Bank
41	#555	Lock Two
42	#555	Database 2
43	#555	10 Million
44	#555	Extra Ball
45	#555	Multiball
46	#555	Hurry Up Lit
47	#555	Hold Bonus
48	#555	Security Pass
51	#44	Eyes Lower
52	#44	Eyes Upper
53	#555	5,000,000
54	#555	3,000,000
55	#555	1,000,000
56	#555	750,000
57	#555	500,000
58	#555	250,000
61	#555	Left CPU Lit
62	#555	Left Vault Key
63	#555	Left Silent Alarm
64	#555	Left Passcode
65	#555	Left Checkpoint
66	#555	Lock 1
67	#555	Database 1
68	#555	Left Ramp
71	#555	Right CPU Lit
72	#555	Right Vault Key
73	#555	Right Silent Alarm
74	#555	Right Passcode
75	#555	Right Checkpoint
76	#555	Right Top Bank Target
77	#555	Right Middle Bank Target
78	#555	Right Bottom Bank Target

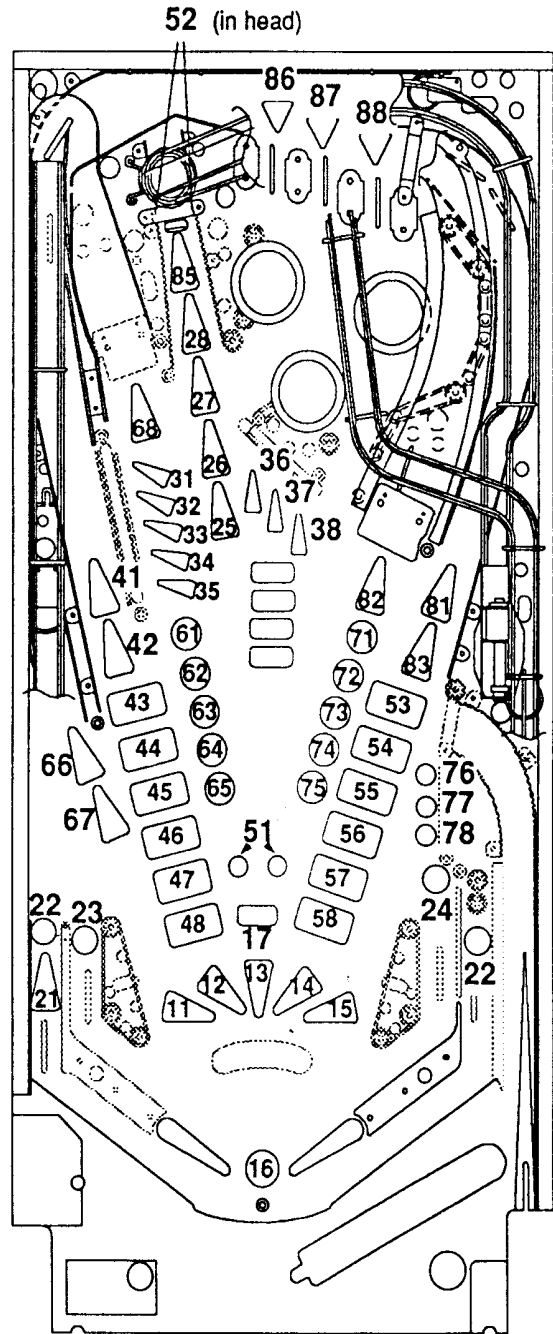

84

No.	Bulb	Description
81	#555	Chase Value
82	#555	Right Ramp
83	#555	Hurry Up
84	#44	Start Button
85	#44	Drop Target
86	#555	Top Left Lane
87	#555	Top Center Lane
88	#555	Top Right Lane

Part Number for #44 bulb is 24-6549.

Part Number for #555 bulb is 24-8768.

# Switch Matrix

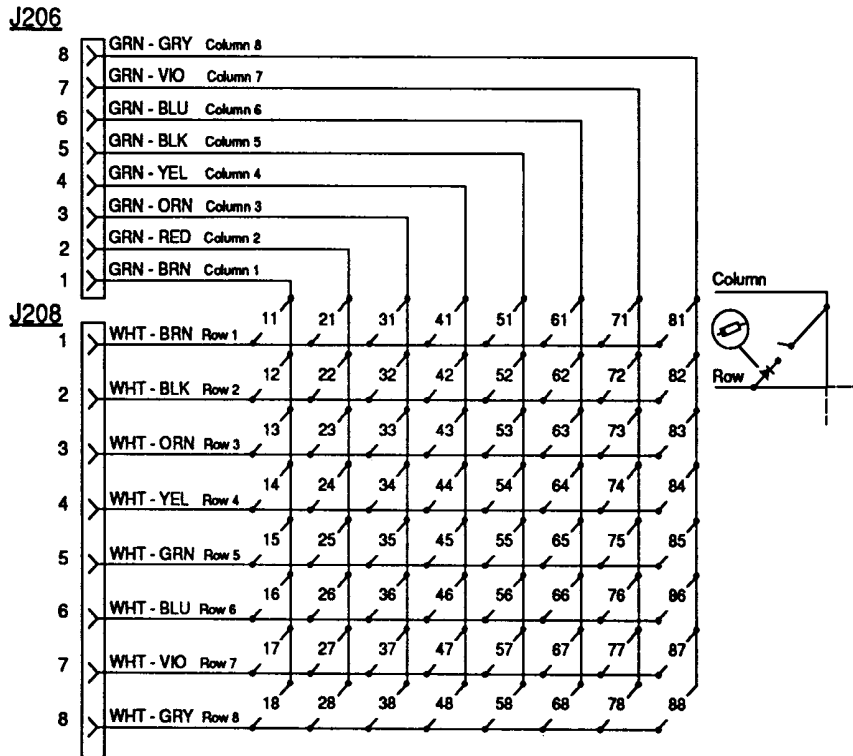

## Switch Matrix

White Green

Dedicated Grounded Switches	Column		1	2	3	4	5	6	7	8
	Row		Green-Brown J206-1 U20-18	Green-Red J206-2 U20-17	Green-Orange J206-3 U20-16	Green-Yellow J206-4 U20-15	Green-Black J206-5 U20-14	Green-Blue J206-6 U20-13	Green-Violet J206-7 U20-12	Green-Gray J206-8 U20-11
Orange-Brown Left Coin Chute D1	1	White-Brown J206-1 U18-11	Right Flipper	Stam Tilt	Gun Loaded	Left Jet	Left Lock	Left Ramp Entry	Target 1 High	Not Used
Orange-Red Center Coin Chute D2	2	White-Red J206-2 U18-9	Left Flipper	Coin Door Closed	Gun Mark	Right Jet	Not Used	Left Ramp Made	Target 2	Not Used
Orange-Black Right Coin Chute D3	3	White-Orange J206-3 U18-5	Start Button	Ticket Dispenser	Gun Home	Bottom Jet	Low Escape Route	Right Ramp Entry	Target 3	Not Used
Orange-Yellow 4th Coin Chute D4	4	White-Yellow J206-4 U18-7	Ptumb Bob Tilt	Test Position, Always Closed	Grip Trigger	Left Sling	High Escape Route	Right Ramp Made	Target 4	Not Used
Orange-Green Normal Function Service Credits D5	5	White-Green J206-5 U18-11	Trough Left	Left Outlane	Not Used	Right Sling	Top Lock	Low Chase Loop	Target 5 Low	Not Used
Orange-Blue Normal Function Volume Down D6	6	White-Blue J206-6 U18-9	Trough Center	Left Return Lane	Mid Left Stand-up Target	Top Right Stand-up Target	Top Lane Left	High Chase Loop	Ball Popper	Not Used
Orange-Violet Normal Function Volume Up D7	7	White-Violet J206-7 U18-5	Trough Right	Right Return Lane	Mid Center Stand-up Target	Mid Right Stand-up Target	Top Lane Center	Not Used	Drop Target	Not Used
Orange-Gray Normal Function Begin Test D8	8	White-Gray J206-8 U18-7	Outhole	Right Outlane	Mid Right Stand-up Target	Bot Right Stand-up Target	Top Lane Right	Not Used	Shooter	Not Used

# Switch Locations

Item	Switch Number	Switch Assy.	Description
11	SW-10A-48	A-9990-1	Right Flipper
12	SW-10A-48	A-9990-1	Left Flipper
13	---	20-9663-3	Start Button
14	---	20-6502-A	Plumb Bob Tilt
15	5647-12693-08	A-11680	Trough Left
16	5647-09957-00	B-11348	Trough Center
17	5647-09957-00	B-11348	Trough Right
18	5647-12133-12	A-10417	Outhole
21	---	20-1066	Slam Tilt
22	---	A-8630	Coin Door Closed
23	---	(optional)	Token Dispenser
24	---	A-8630	Always Closed
25	5647-12693-19	A-12688	Left Outlane
26	5647-12693-19	A-12688	Left Return Lane
27	5647-12693-19	A-12688	Right Return Lane
28	5647-12693-19	A-12688	Right Outlane
31	5647-12693-06	A-14505	Gun Loaded
32	5647-12693-06	A-14505	Gun Mark
33	5647-12693-06	A-14505	Gun Home
34	5647-12693-03	A-14754	Grip Trigger
35	---	---	Not Used
36	---	A-14691-4	Mid. Left St-Up
37	---	A-14691-4	Mid. Center St-Up
38	---	A-14691-4	Mid. Right St-Up
41	SW-11A-37	B-12030-2	Left Jet
42	SW-11A-37	B-12030-2	Right Jet
43	SW-11A-37	B-12030-2	Bottom Jet
44	B-8284-1	SW-1A-114	Left Sling
45	B-8284-1	SW-1A-114	Right Sling
46	---	A-14690-15	Right Top St-Up
47	---	A-14690-15	Right Mid. St-Up
48	---	A-14690-15	Right Bot. St-Up
51	5647-12133-11	A-9381-R	Left Lock
52	---	---	Not Used
53	5647-12693-19	A-12688	Low Escape Route
54	5647-12693-19	A-12688	High Escape Route
55	5647-12133-11	A-9381-R	Top Lock
56	5647-12693-19	A-12688	Top Left Lane
57	5647-12693-19	A-12688	Top Center Lane
58	5647-12693-19	A-12688	Top Right Lane
61	5647-12693-11	A-13627-2	Left Ramp Entry
62	5647-12693-21	A-14490	Left Ramp Made
63	5647-12693-11	A-14492	Right Ramp Entry
64	5647-12693-21	A-14491	Right Ramp Made
65	5647-12693-19	A-12688	Low Chase Loop
66	5647-12693-19	A-12688	High Chase Loop
67	---	---	Not Used
68	---	---	Not Used
71	---	A-14690-5	Target 1 High
72	---	A-14690-5	Target 2
73	---	A-14690-5	Target 3
74	---	A-14690-5	Target 4
75	---	A-14690-5	Target 5 Low
76	SW-1A-167	A-11688	Ball Popper
77	5647-12693-31	A-14615	Drop Target

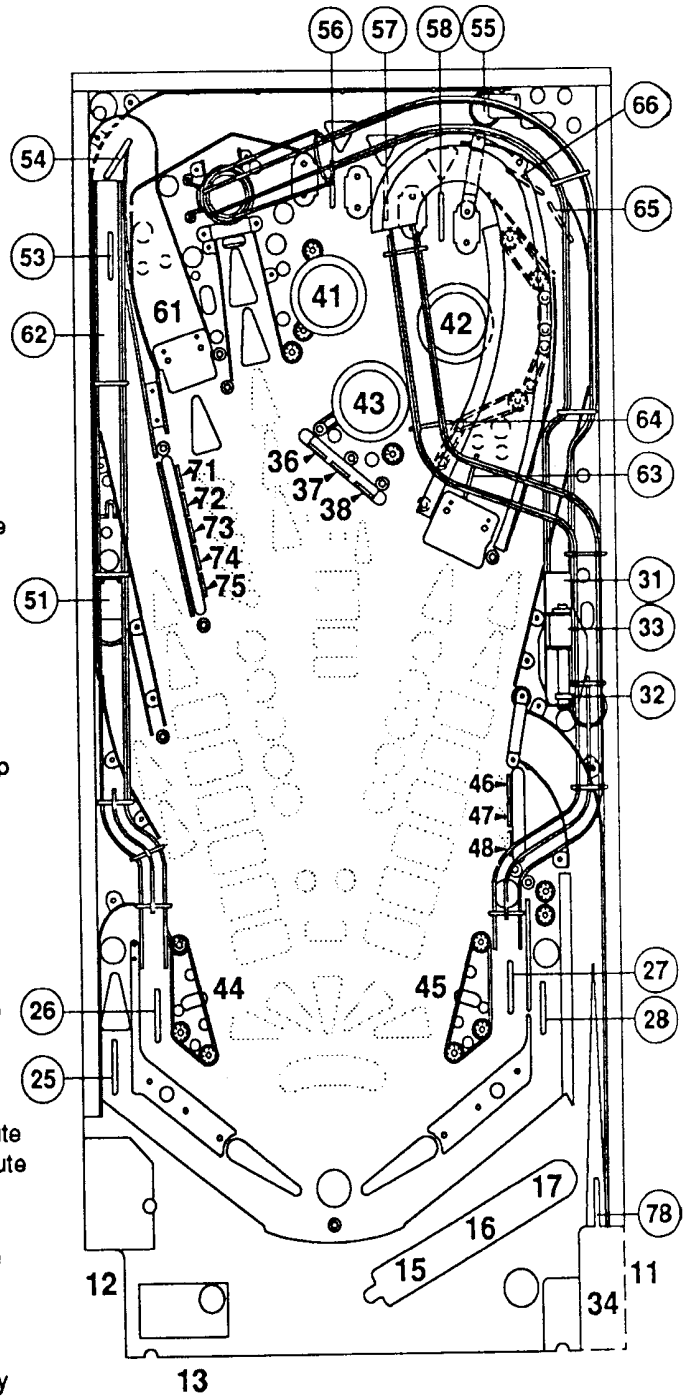

Item	Switch Number	Switch Assy	Description
78	5647-12693-04	A-11619-1	Shooter
81-88	---	---	Not Used

## Solenoid Table

Sol. No.	Function	Solenoid Type	Wire Color	Connections		Driver Trnstr	Solenoid Part Number Flashlamp Type
				Playfield-Inser			
01	Ball Popper	High Power	Vio-Brn	J130-1		Q82	AE-23-800
02	Gun Kicker	High Power	Vio-Red	J130-2		Q80	AE-24-900
03	Outhole	High Power	Vio-Orn	J130-4		Q78	AE-27-1200
04	Trough	High Power	Vio-Yel	J130-5		Q76	AE-26-1200
05	Right Sling	High Power	Vio-Grn	J130-6		Q64	AE-26-1500
06	Left Sling	High Power	Vio-Blu	J130-7		Q66	AE-26-1500
07	Knocker	High Power	Vio-Blk	J130-8		Q68	AE-23-800
08	Kickback	High Power	Vio-Gry	J130-9		Q70	AE-23-800
09	Plunger	Low Power	Brn-Blk	J127-1		Q58	AE-23-800
10	Top Lock	Low Power	Brn-Red	J127-3		Q56	AE-26-1500
11	Gun Motor	Low Power	Brn-Orn	J127-4		Q54	14-7963
12	Not Used	Low Power	Brn-Yel	J127-5		Q52	
13	Left Jet	Low Power	Brn-Grn	J127-6		Q50	AE-26-1200
14	Right Jet	Low Power	Brn-Blu	J127-7		Q48	AE-26-1200
15	Bottom Jet	Low Power	Brn-Vio	J127-8		Q46	AE-26-1200
16	Left Lock	Low Power	Brn-Gry	J127-9		Q44	AE-26-1500
17	Hot Dog Flashlamps	Flasher	Blk-Brn	J126-1	J125-2	Q42	#906 (4 PL)
18	Right Sling Flashlamps	Flasher	Blk-Red	J126-2	J125-3	Q40	#906 (1 BB), #89 (1 PL)
19	Left Sling Flashlamps	Flasher	Blk-Orn	J126-3	J125-5	Q38	#906 (1 BB), #89 (1 PL)
20	Left Lock Flashlamps	Flasher	Blk-Yel	J126-4		Q36	#906 (1 BB), #89 (1 PL)
21	Gun Flashlamps	Special	Blu-Grn	J126-5	J125-7	Q28	#89 (2 PL)
22	Right Ramp Flashlamps	Special	Blu-Blk	J126-6	J125-8	Q30	#906 (1 BB), #89 (1PL)
23	Left Ramp Flashlamps	Special	Blu-Vio	J126-7	J125-9	Q34	#906 (1 BB), #89 (1 PL)
24	Backglass Flashlamp	Special	Blu-Gry			Q32	#906 (1 BB)
25	Targets Flashlamps	Special	Blu-Brn	J122-1		Q26	#89 (2 PL)
26	Left Popper Flashlamps	Special	Blu-Red	J122-2		Q24	#89 (2 PL)
27	Right Popper Flashlamps	Special	Blu-Orn	J122-3		Q22	#89 (2 PL)
28	Drop Target	Special	Blu-Yel	J122-4		Q20	AE-26-1200
<b>General Illumination</b>							
01	Top Insert G.I.	G.I.	Wht-Brn	J120-7		Q18	#555
02	Left Playfield G.I.	G.I.	Wht-Vio	J119-1		Q10	#555
03	Right Playfield G.I.	G.I.	Wht-Yel	J121-9		Q14	#555
04	Not Used	G.I.	Wht-Orn	J120-8		Q16	
05	Bottom Insert G.I.	G.I.	Wht-Grn	J120-10		Q12	#555
	Lower Right Flipper		Blu-Yel	J109-7			FL-11630
	Lower Left Flipper		Gry-Yel	J109-5			FL-11630



# Solenoid Locations

No.	Part No.	Description
01	AE-23-800	Ball Popper
02	AE-24-900	Gun Kicker
03	AE-27-1200	Outhole
04	AE-26-1200	Trough
05	AE-26-1500	Right Sling
06	AE-26-1500	Left Sling
07	AE-23-800	Knocker
08	AE-23-800	Kickback
09	AE-23-800	Plunger
10	AE-26-1500	Top Lock
11	14-7963	Gun Motor
12	SM1-26-600	Knock Down
13	AE-26-1200	Left Jet
14	AE-26-1200	Right Jet
15	AE-26-1200	Bottom Jet
16	AE-26-1500	Left Lock
17	#906	Hot Dog Flashlamps
18	#906, #89	Right Sling Flashlamps
19	#906, #89	Left Sling Flashlamps
20	#906, #89	Left Lock Flashlamps
21	#89	Gun Flashlamps
22	#906, #89	Right Ramp Flashlamps
23	#906, #89	Left Ramp Flashlamps
24	#906	Backglass Flashlamps
25	#89	Targets Flashlamps
26	#89	Left Popper Flashlamps
27	#89	Right Popper Flashlamps
28	AE-26-1200	Drop Target Flashlamp

## General Illumination Circuits

01	#555	Top Insert String
02	#555	Bottom Insert String
03	#555	Right Playfield String
04	#555	CPU String
05	#555	Left Playfield String

## Flippers

FL-11630	Lower Right Flipper
FL-11630	Lower Left Flipper

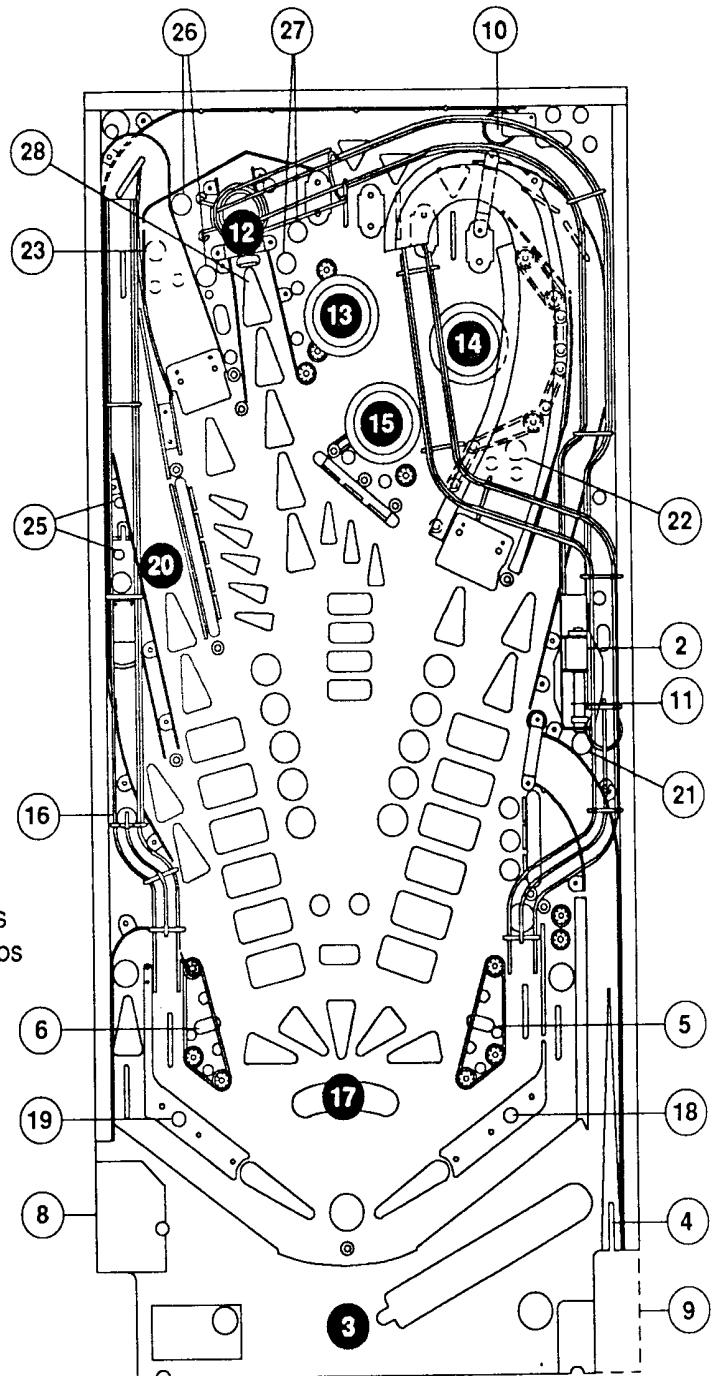

# Rubber Ring Locations

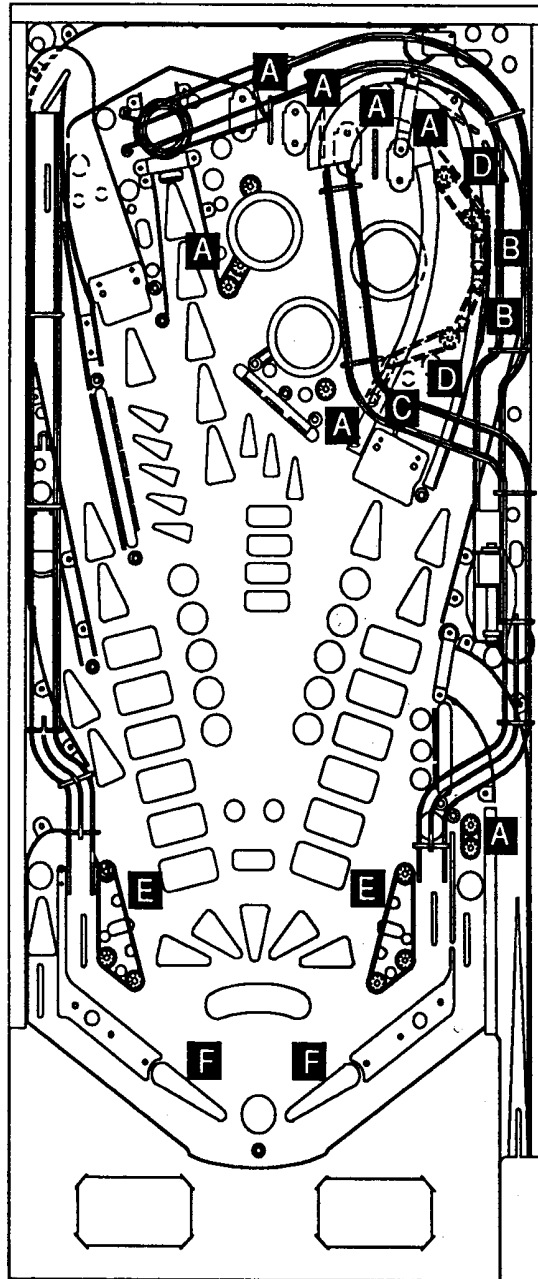

Item	Part Number	Description	Quantity
A	23-6300	Rubber Ring, 5/16"	12
B	23-6301	Rubber Ring, 3/4"	5
C	23-6302	Rubber Ring, 1"	2
D	23-6303	Rubber Ring, 1-1/4"	3
E	23-6306	Rubber Ring, 2-1/2"	2
F	23-6519-4	Rubber Ring, Flipper	2

## **Section 3**

# **Wiring Diagrams and Schematics**

**Flipper Wiring**  
**Coin Door Interface Board Wiring**  
**Motor Regulator Board Wiring**  
**Motor EMI Filter Board Wiring**  
**Solenoid Wiring**  
**Interboard Wiring**

### **Connector & Component Identification**

Each plug or jack receives a number that identifies the circuit board and position on that board that it connects to. J-designations refer to the male part of a connector. P-designations refer to the female part of a connector. For example, J101 refers to jack 1 of board 1 (a Power Driver Board jack); P206 designates plug 6 of board 2 (a CPU Board plug). Identifying the specific pin number of a connector involves a hyphen, which separates the pin number from the plug or jack designation. For example, J101-3 refers to pin 3 of jack 1 on board 1.

Other game components may also have similar numbers to clarify their locations or related circuits. For example, F501 refers to a fuse located on the Sound Board.

Prefix numbers for the WPC circuit boards are listed below.

- 1- Power Driver Board
- 2-CPU Board
- 5-Sound Board
- 6-Dot Matrix Controller Board
- Dot Matrix Display/Driver Board (no prefix number)

# Flipper and Lane Change Circuit

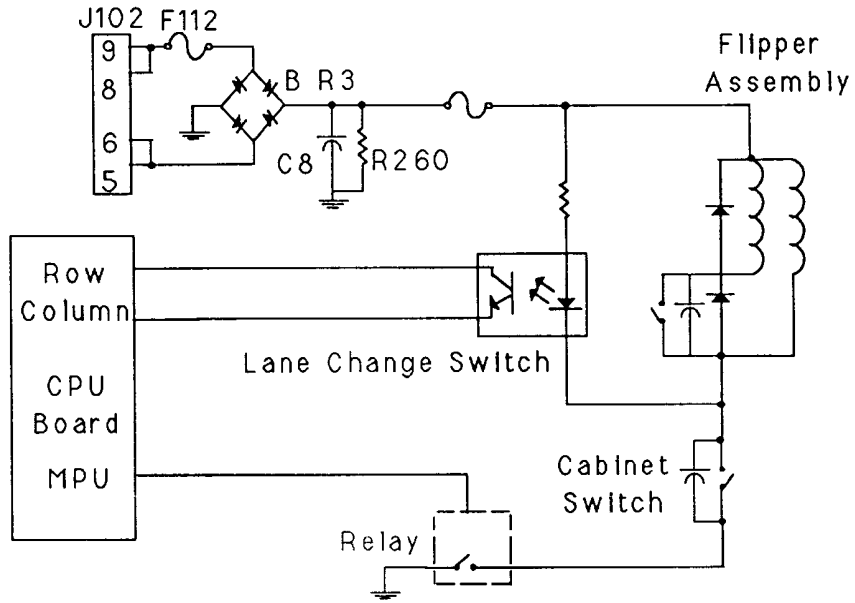

Wiring Diagram

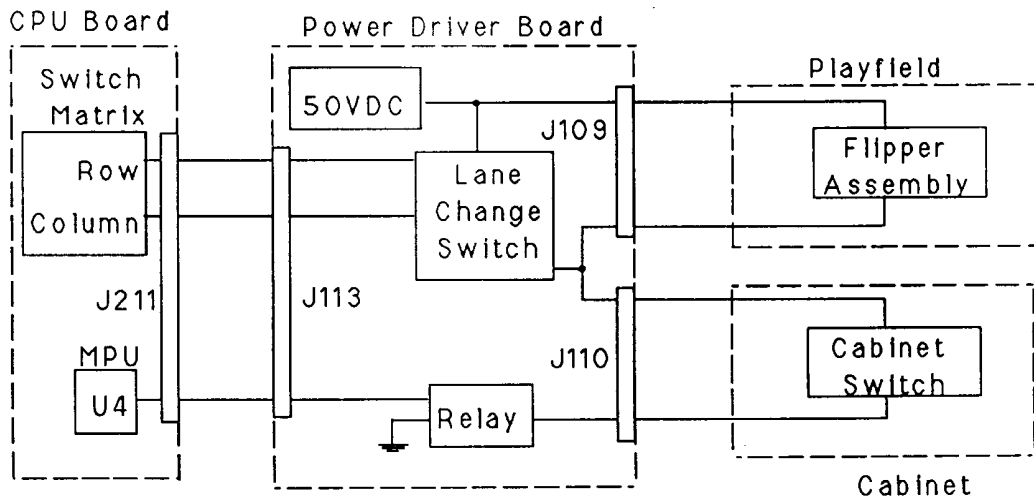

Block Diagram

Coin Door Interface Board Schematic

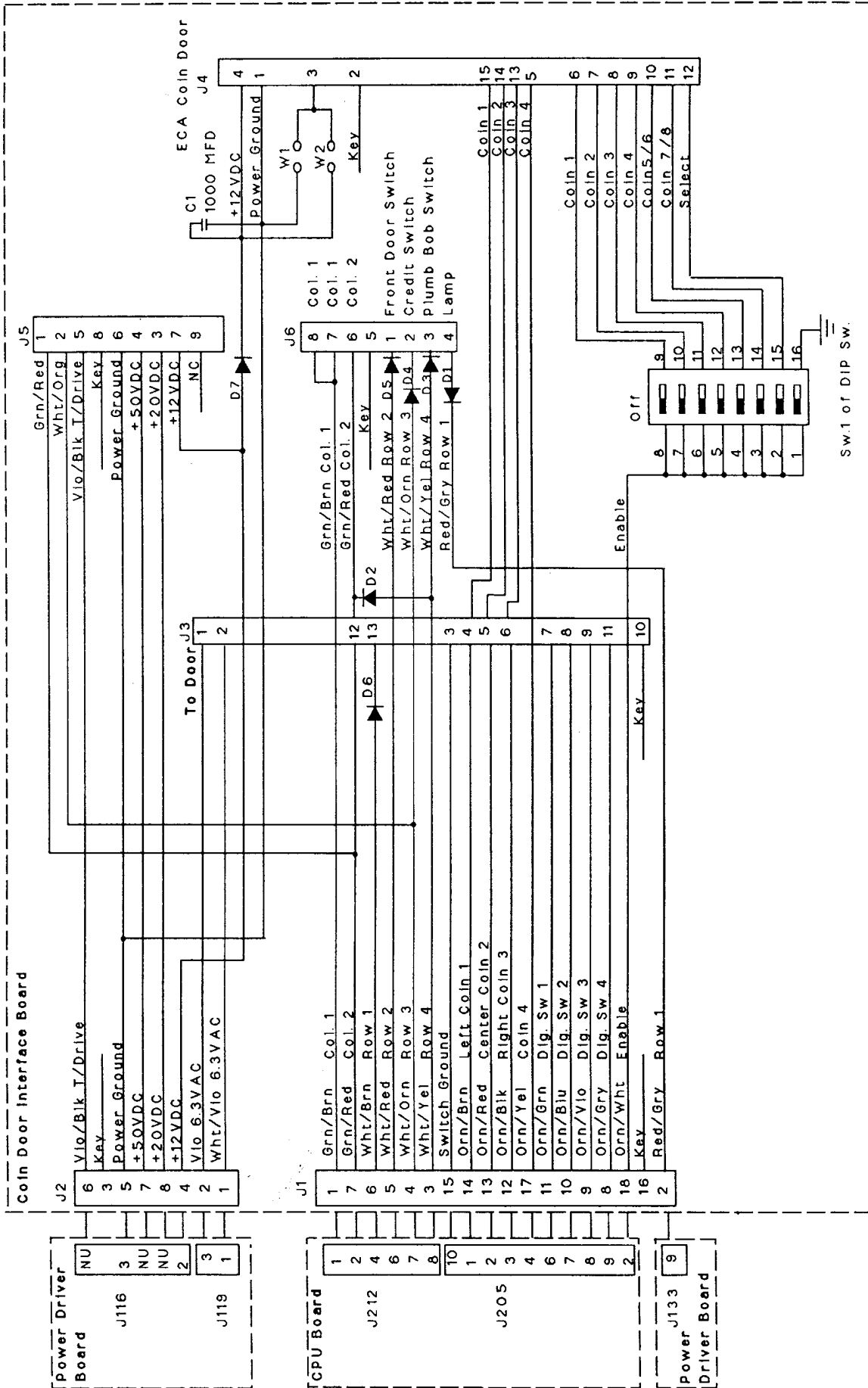

# Motor Regulator Board

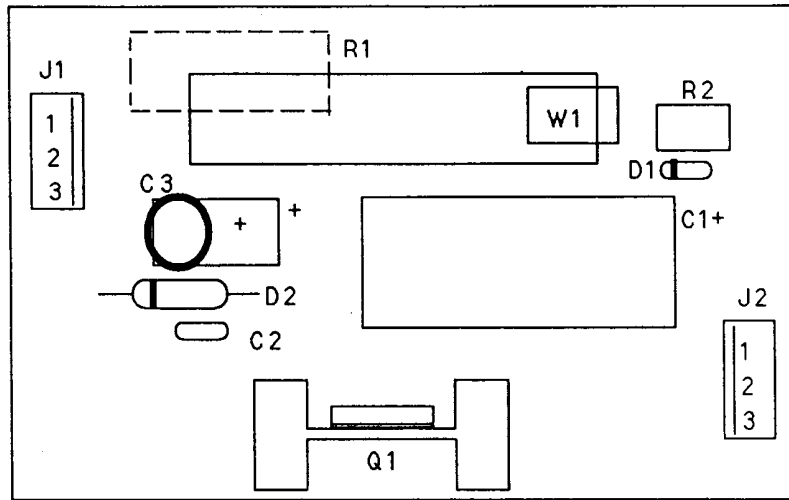

Board Assembly

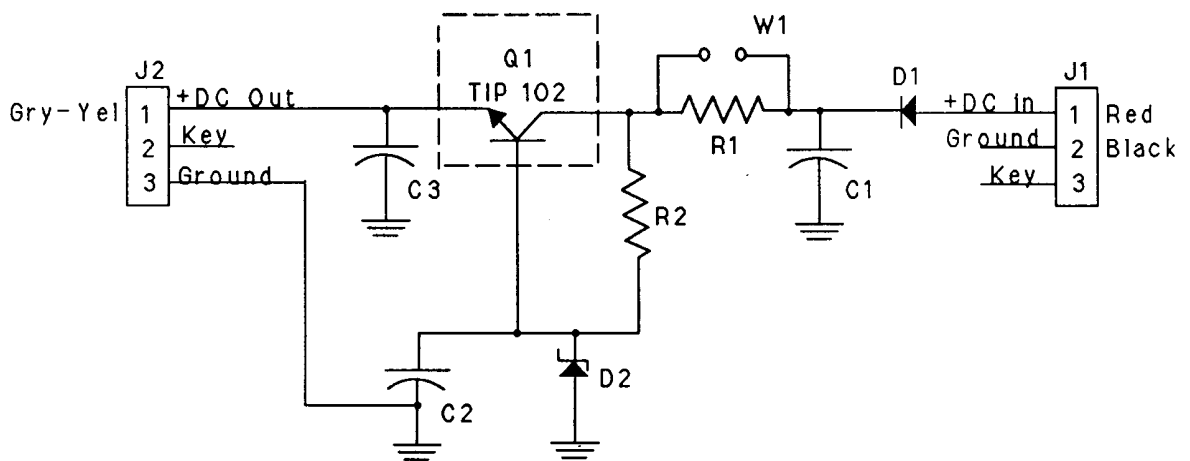

Schematic

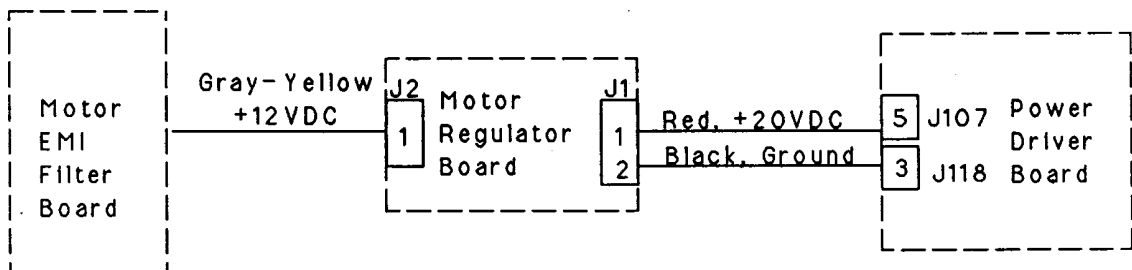

Circuit Diagram

# Motor EMI Filter Board

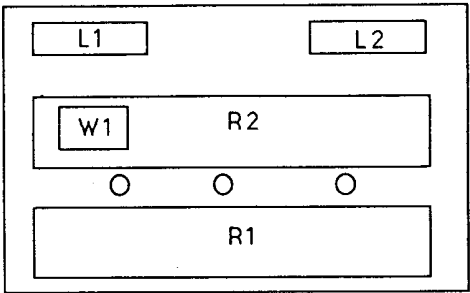

Board Assembly

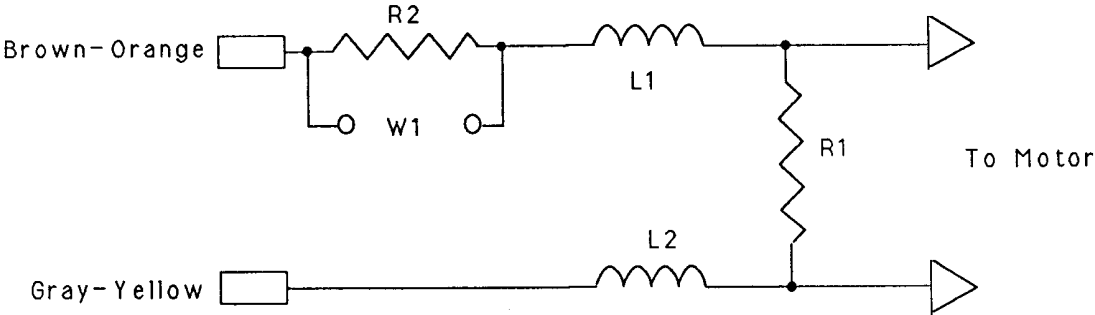

Schematic

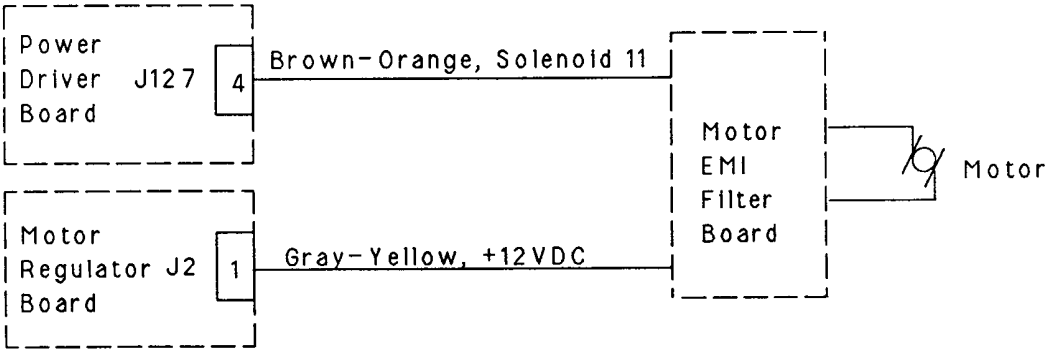

Circuit Diagram

# Solenoid Wiring

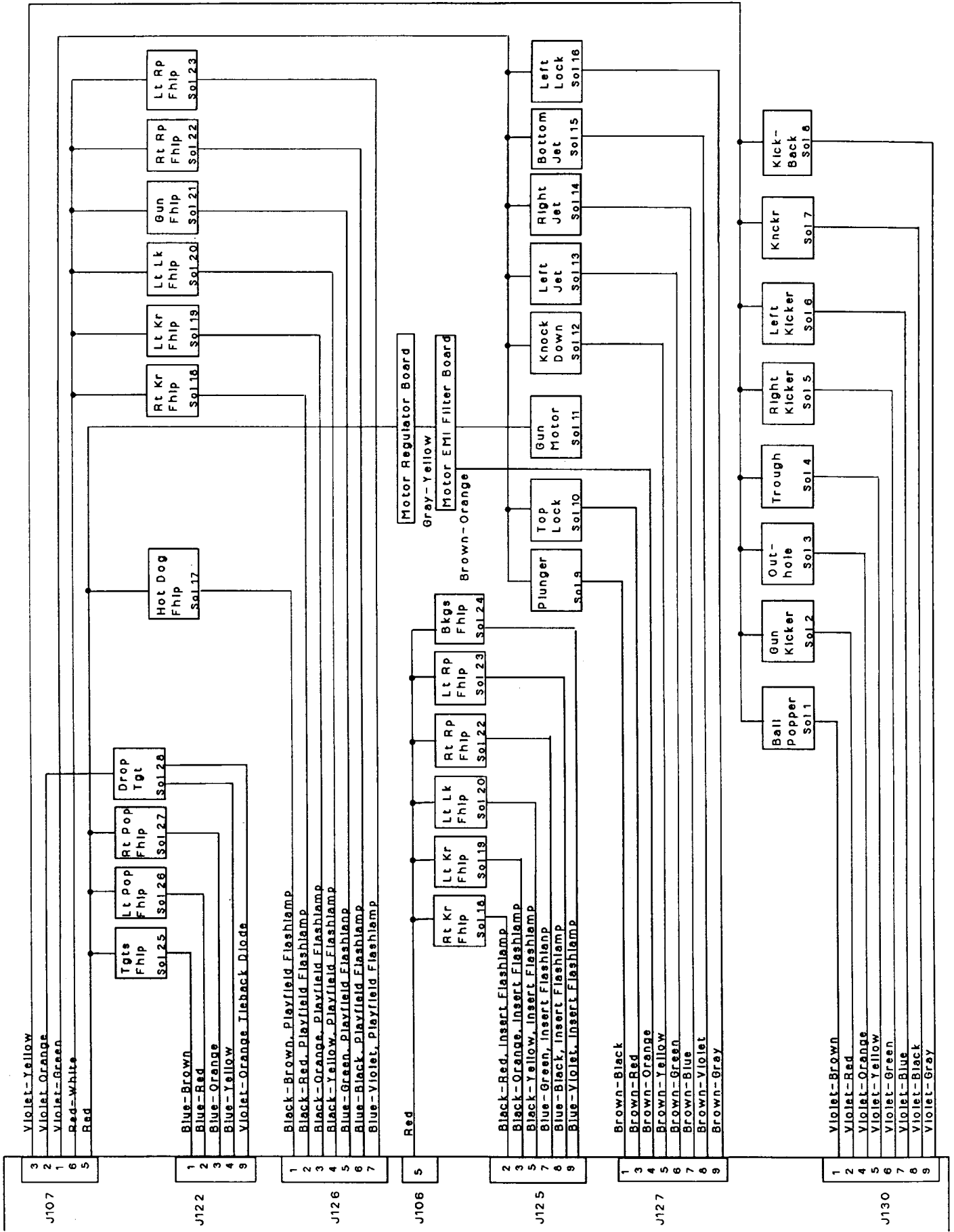

Power Driver Board



# Interboard Wiring

## Switch Circuits

Wire Color	Function	Connector from CPU		
		To Playfield	To Cabinet	Transistor
Green/Brown	Column 1	J207-1	J212-1	U20-18
Green/Red	Column 2	J207-2	J212-2	U20-17
Green/Orange	Column 3	J207-3		U20-16
Green/Yellow	Column 4	J207-4		U20-15
Green/Black	Column 5	J207-5		U20-14
Green/Blue	Column 6	J207-6		U20-13
Green/Violet	Column 7	J207-7		U20-12
Green/Gray	Column 8	Not Used		U20-11
White/Brown	Row 1	J209-1	J212-4	U18-11
White/Red	Row 2	J209-2	J212-6	U18-9
White/Orange	Row 3	J209-3	J212-7	U18-5
White/Yellow	Row 4	J209-4	J212-8	U18-7
White/Green	Row 5	J209-5		U19-11
White/Blue	Row 6	J209-7		U19-9
White/Violet	Row 7	J209-8		U19-5
White/Gray	Row 8	J209-9		U19-7
Orange/ Brown	Direct 1 Left Coin		J205-1	U17-5
Orange/Red	Direct 2 Center Coin		J205-2	U17-7
Orange/Black	Direct 3 Right Coin		J205-3	U17-11
Orange/Yellow	Direct 4 4th Coin		J205-4	U17-9
Orange/Green	Direct 5 Escape/Service		J205-6	U16-9
Orange/Blue	Direct 6 Down/Vol Down		J205-7	U16-11
Orange/Violet	Direct 7 Up/ Vol Up		J205-8	U16-7
Orange/Gray	Direct 8 Enter/Test		J205-9	U16-5
Black	Ground		J205-10	
Orange/White	Enable		J205-12	

## Lamp Circuits

Wire Color	Function	Connectors from Power Driver Board		
		To Playfield	To Cabinet	Transistor
Yellow/Brown	Column 1	J138-1		Q98
Yellow/Red	Column 2	J138-2		Q97
Yellow/Orange	Column 3	J138-3		Q96
Yellow/Black	Column 4	J138-4		Q95
Yellow/Green	Column 5	J138-5		Q94
Yellow/Blue	Column 6	J138-6		Q93
Yellow/Violet	Column 7	J138-7		Q92
Yellow/Gray	Column 8	J138-9	J136-3	Q91
Red/Brown	Row 1	J133-1		Q90
Red/Black	Row 2	J133-2		Q89
Red/Orange	Row 3	J133-4		Q88
Red/Yellow	Row 4	J133-5	J135-5	Q87
Red/Green	Row 5	J133-6		Q86
Red/Blue	Row 6	J133-7		Q85
Red/Violet	Row 7	J133-8		Q84
Red/Gray	Row 8	J133-9		Q83

# Interboard Wiring

## Solenoid Circuits

Connectors from Power Driver Board

Wire Color	Function	To Playfield	To Insert	Transistor
Violet/Brown	Solenoid 1, High Power	J130-1		Q82
Violet/Red	Solenoid 2, High Power	J130-2		Q80
Violet/Orange	Solenoid 3, High Power	J130-4		Q78
Violet/Yellow	Solenoid 4, High Power	J130-5		Q76
Violet/Green	Solenoid 5, High Power	J130-6		Q64
Violet/Blue	Solenoid 6, High Power	J130-7		Q66
Violet/Black	Solenoid 7, High Power	J130-8		Q68
Violet/Gray	Solenoid 8, High Power	J130-9		Q70
Brown/Black	Solenoid 9, Low Power	J127-1		Q58
Brown/Red	Solenoid 10, Low Power	J127-3		Q56
Brown/Orange	Solenoid 11, Low Power	J127-4		Q54
Brown/Yellow	Solenoid 12, Low Power	J127-5		Q52
Brown/Green	Solenoid 13, Low Power	J127-6		Q50
Brown/Blue	Solenoid 14, Low Power	J127-7		Q48
Brown/Violet	Solenoid 15, Low Power	J127-8		Q46
Brown/Gray	Solenoid 16, Low Power	J127-9		Q44
Black/Brown	Sol. 17, Flasher 1, No Diode	J126-1		Q42
Black/Red	Sol. 18, Flasher 2, No Diode	J126-2		Q40
Black/Orange	Sol. 19, Flasher 3, No Diode	J126-3		Q38
Black/Yellow	Sol. 20, Flasher 4, No Diode	J126-4	J125-2	Q36
Blue/Green	Sol. 21, Special 1 Drive	J126-5	J125-3	Q28
Blue/Black	Sol. 22, Special 2 Drive	J126-6	J125-5	Q30
Blue/Violet	Sol. 23, Special 3 Drive	J126-7		Q34
Blue/Gray	Sol. 24, Special 4 Drive		J125-7	Q32
Blue/Brown	Sol. 25, Special 5 Drive	J122-1	J125-8	Q26
Blue/Red	Sol. 26, Special 6 Drive	J122-2	J125-9	Q24
Blue/Orange	Sol. 27, Special 7 Drive	J122-3		Q22
Blue/Yellow	Sol. 28, Special 8 Drive	J122-4		Q20
Violet/Orange	Sol. 28, Tieback Diode	J122-9		

## Flipper Circuits

Connectors from Power Driver Board

Wire Color	Function	To Playfield
Gray/Yellow	Left Flipper Power	J109-5
Blue/Yellow	Right Flipper Power	J109-7
Black/Blue	Upper Left Flipper	Not Used
Blue/Gray	Lower Left Flipper	J109-3
Black/Yellow	Upper Right Flipper	Not Used
Blue/Violet	Lower Right Flipper	J109-4
Black/Blue	Upper Left Flipper	J110-9, Not Used
Blue/Gray	Lower Left Flipper	J110-7
Black/Yellow	Upper Right Flipper	J110-8, Not Used
Blue/Violet	Lower Right Flipper	J110-6
Orange/Gray	Left Flipper Ground	J110-2, 1
Orange/Violet	Right Flipper Ground	J110-4, 3

## Interboard Wiring

### General Illumination Circuits

Wire Color	Function	Connectors from Power Driver Board			Transistor
		To Playfield	To Cabinet	To Insert	
Green	Feed 1	J121-5		J120-2	Q12
Violet	Feed 2	J121-6	J119-3		Q10
Brown	Feed 3			J120-1	Q18
Yellow	Feed 4	J121-3			Q14
Orange	Feed 5				Q16
White/Green	Return 1	J121-10		J120-8	F7
White/Violet	Return 2	J121-11	J119-1		F6
White/Brown	Return 3			J120-7	F10
White/Yellow	Return 4	J121-9			F8
White/Orange	Return 5				F9

### Power Circuits

Wire Color	Function	Connectors from Power Driver Board			To PC Boards
		To Cabinet	To Dot Controller	To Playfield	
Gray	Digital +5V		J117-4		J114-3, 4
Gray/Green	Switch +12V				J114-1, 2
Gray/Yellow	Analog +12V	J116-2	J117-2		
Black	Ground	J116-3	J117-3	J118-3	J114-5, 7

### Power Circuits

Wire Color	Function	Connectors from Power Driver Board	
		To Playfield	To Insert
Violet/Yellow	High Power 50V	J107-3	
Violet/Orange	Low Power 50V	J107-2	
Violet/Green	Other 50V	J107-1	
Red	Flasher 20V	J107-5	J106-5
Red/White	Flasher 20V	J107-6	
White/Blue	50VAC	Not Used	
White/Blue	50VAC	Not Used	
Black	Ground	Not Used	

### Logic Circuits

Wire Color	Function	
Ribbon Cable	Data	J201 To /from Dot Matrix Controller
Ribbon Cable	Data	J202 To /from Sound Board & Dot Matrix Controller
Ribbon Cable	Data	J204 Not Used

Connectors from Power Driver Board		
Black	Ground	J210-1
Black	Ground	J210-3
Gray	+5VDC	J210-4
Gray	+5VDC	J210-5
Gray/Green	+12VDC	J210-6
Gray/Green	+12VDC	J210-7
Ribbon Cable	Data	J211

## Interboard Wiring

### Display Circuits

Wire Color	Function	
Ribbon Cable	Data	J601 To/from CPU & Sound Board
Ribbon Cable	Data	J602 To/from CPU Board
Ribbon Cable	Data	J603 To/from Dot Matrix Display/Driver Board

#### Connector to Dot Matrix Display/Driver

Orange	-125V	J604-1
Blue	-113V	J604-2
Black	Ground	J604-4
Black	Ground	J604-5
Gray	+5V	J604-6
Gray/Yellow	+12V	J604-7
Brown	+62V	J604-8

#### Connector from Transformer (AC)

White	80VAC	J605-1
White	80VAC	J605-2
Violet	100VAC	J605-3
Violet	100VAC	J605-5

#### Connector from Power Driver Board

Black	Ground	J606-1
Black	Ground	J606-3
Gray	+5V	J606-4
Gray	+5V	J606-5
Gray/Yellow	+12V	J606-6
Gray/Yellow	+12V	J606-7

### Sound Circuits

Wire Color	Function	
Ribbon Cable	Data	J506 To/from CPU Board & Dot Matrix Controller

#### Connector From Transformer Secondary

Gray/Green	+12VDC	J501-1
Gray/Green	+12VDC	J501-2
Gray	+5VDC	J501-4
Gray	+5VDC	J501-5
Gray/White	-12VDC	J501-6
Gray/White	-12VDC	J501-7

#### Power from CPU/Power Driver Board

Gray	+5VDC	J502-1
Gray	+5VDC	J502-3
Black	Ground	J502-4
Black	Ground	J502-5

#### Cabinet Speaker Connection

Black/Yellow	Speaker	J504-2
--------------	---------	--------

#### Backbox Speaker Connection

Black/Yellow	Speaker	J505-3
--------------	---------	--------

### Lamp Matrix

		Yellow (B+)  Red							
Column	1 Yellow-Brown J133-1 Q96	2 Yellow-Red J133-2 Q97	3 Yellow-Orange J133-3 Q96	4 Yellow-Black J133-4 Q95	5 Yellow-Green J133-5 Q94	6 Yellow-Blue J133-6 Q93	7 Yellow-Violet J133-7 Q92	8 Yellow-Gray J133-9 Q91	
Row									
1	Red-Brown J133-1 Q90 Multiplier 2X 11	Kickback 21	Target 1 High 31	Lock Two 41	Eyes Lower 51	Left CPU Lit 61	Right CPU Lit 71	Chase Value 81	
2	Red-Black J133-2 Q89 Multiplier 4X 12	Special 22	Target 2 32	Data Base 2 42	Eyes Upper 52	Left Vault Key 62	Right Vault Key 72	Right Ramp 82	
3	Red-Orange J133-4 Q88 Hold Bonus 13	Left Return Lane 23	Target 3 33	10 Million 43	5,000,000 53	Left Silent Alarm 63	Right Silent Alarm 73	Hurry Up 83	
4	Red-Yellow J133-5 Q87 Multiplier 6X 14	Right Return Lane 24	Target 4 34	Extra Ball 44	3,000,000 54	Left Passcode 64	Right Passcode 74	Start Button 84	
5	Red-Green J133-6 Q86 Multiplier 8X 15	Data Base 3 25	Target 5 Low 35	Multi-ball 45	1,000,000 55	Left Checkpoint 65	Right Checkpoint 75	Drop Target 85	
6	Red-Blue J133-7 Q85 Shoot Again 16	Load Gun 26	Middle Target Bank Left 36	Light Hurry Up 46	750,000 56	Lock 1 66	Right Bank Top 76	Top Lane Left 86	
7	Red-Violet J133-8 Q84 Mouth 17	Extra Ball 27	Middle Target Bank Center 37	Hold Bonus 47	500,000 57	Data Base 1 67	Right Bank Middle 77	Top Lane Center 87	
8	Red-Gray J133-9 Q83 Not Used 18	Load for Jackpot 28	Middle Target Bank Right 38	Security Pass 48	250,000 58	Left Ramp 68	Right Bank Bottom 78	Top Lane Right 88	

### Switch Matrix

		White  Green							
Dedicated Grounded Switches	Column	1 Green-Brown J207-1 U20-18	2 Green-Red J207-2 U20-17	3 Green-Orange J207-3 U20-16	4 Green-Yellow J207-4 U20-15	5 Green-Black J207-5 U20-14	6 Green-Blue J207-6 U20-13	7 Green-Violet J207-7 U20-12	8 Green-Gray J207-8 U20-11
Row									
Orange-Brown Left Coin Chute D1	White-Brown J209-1 U18-11 1	Right Flipper 11	Slam Tilt 21	Gun Loaded 31	Left Jet 41	Left Lock 51	Left Ramp Entry 61	Target 1 High 71	Not Used 81
Orange-Red Center Coin Chute D2	White-Red J209-2 U18-9 2	Left Flipper 12	Coin Door Closed 22	Gun Mark 32	Right Jet 42	Not Used 52	Left Ramp Made 62	Target 2 72	Not Used 82
Orange-Black Right Coin Chute D3	White-Orange J209-3 U18-5 3	Start Button 13	Ticket Dispenser 23	Gun Home 33	Bottom Jet 43	Low Escape Route 53	Right Ramp Entry 63	Target 3 73	Not Used 83
Orange-Yellow 4th Coin Chute D4	White-Yellow J209-4 U18-7 4	Plumb Bob Tilt 14	Test Position, Always Closed 24	Grip Trigger 34	Left Sling 44	High Escape Route 54	Right Ramp Made 64	Target 4 74	Not Used 84
Orange-Green Normal Function   Test Function Service Credits   Escape D5	White-Green J209-5 U19-11 5	Trough Left 15	Left Outlane 25	Not Used 35	Right Sling 45	Top Lock 55	Low Chase Loop 65	Target 5 Low 75	Not Used 85
Orange-Blue Normal Function   Test Function Volume Down   Down D6	White-Blue J209-7 U19-9 6	Trough Center 16	Left Return Lane 26	Mid Left Stand-up Target 36	Top Right Stand-up Target 46	Top Lane Left 56	High Chase Loop 66	Ball Popper 76	Not Used 86
Orange-Violet Normal Function   Test Function Volume Up   Up D7	White-Violet J209-8 U19-5 7	Trough Right 17	Right Return Lane 27	Mid Center Stand-up Target 37	Mid Right Stand-up Target 47	Top Lane Center 57	Not Used 67	Drop Target 77	Not Used 87
Orange-Gray Normal Function   Test Function Begin   Enter Test D8	White-Gray J209-9 U19-7 8	Outhole 18	Right Outlane 28	Mid Right Stand-up Target 38	Bot Right Stand-up Target 48	Top Lane Right 58	Not Used 68	Shooter 78	Not Used 88

## WARNINGS & NOTICES

### **WARNING**

**FOR SAFETY AND RELIABILITY**, substitute parts and equipment modifications are not recommended. Use of Non-WILLIAMS parts or modifications of game circuitry, may adversely affect game play, or may cause injuries.

**SUBSTITUTE PART OR EQUIPMENT MODIFICATIONS** may void FCC Type Acceptance.

**BECAUSE THIS GAME IS PROTECTED** by Federal copyright, trademark, and patent laws, unauthorized game conversions may be illegal under Federal law.

**THIS 'CONVERSION' PRINCIPLE ALSO APPLIES** to unauthorized facsimiles of WILLIAMS equipment, logos, designs, publications, assemblies, and games (or game feature not deemed to be public domain), whether manufactured with WILLIAMS components or not.

### *Notice*

WILLIAMS, Lane-change and Multi-ball are trademarks of WILLIAMS ELECTRONICS GAMES, INC. Entire contents of this manual © 1991 WILLIAMS ELECTRONICS GAMES, INC.

### **WARNING**

This equipment generates, uses, and can radiate radio frequency energy, and if not installed and used in accordance with the instructions manual, may cause interference to radio communications. It has been tested and found to comply with the limits for a Class A computing device pursuant to Subpart J of Part 15 of FCC Rules, which are designed to provide reasonable protection against such interference when operated in a commercial environment. Operation of this equipment in a residential area is likely to cause interference in which case the user at his own expense will be required to take whatever measures may be required to correct the interference.

### ***RF Interference Notice***

**CABLE HARNESS PLACEMENTS** and ground strap routing on this game have been designed to keep RF radiation and conduction within levels accepted by the FCC Rules.

**TO MAINTAIN THESE LEVELS**, reposition harnesses and reconnect ground straps to their original placements, if they become disconnected during maintenance.

**FCC STICKER.** Check the back of your game to verify that an FCC-certification sticker was attached to your game at the factory. All games that leave the WILLIAMS plant have been tested and found to comply with FCC Rules. Because the sticker is proof of this fact, legal repercussions to the owner and distributor may result, if the sticker is missing. If you receive a game, manufactured after December 1982, that has no FCC sticker, call WILLIAMS for advice or write us a note on your Game Registration Card. Be sure that the card bears your game's serial number.

© 1991 Williams Electronics Games, Inc.

Motion Picture Elements:

© 1991 Carolco Pictures Inc.

Terminator™, EndoSkeleton™, and Depiction of  
EndoSkeleton™ are trademarks of Carolco Pictures Inc. used by  
Williams Electronics Games, Inc. under authorization.

All Rights Reserved.

### **FOR SERVICE...**

CALL your authorized  
WILLIAMS Distributor.

### **WILLIAMS ELECTRONICS GAMES, INC.**

3401 N. California  
Chicago, IL 60618

**CAUTION: Transport this game ONLY  
with hinged backbox DOWN!**